

ESD Diode

Features

- Up to 2 lines protects
- Junction capacitance (Max value:0.8pF)
- Peak Pulse current (8/20 μ s) MAX: 5A
- IEC61000-4-2 (ESD) \pm 25kV (air), \pm 20kV (contact)
- Low leakage current
- Working voltages:5V
- RoHS Compliant

Mechanical Characteristics

- Package: SOT-23
- Lead Finish:Matte Tin
- Case Material: "Green" Molding Compound.
- UL Flammability Classification Rating 94V-0
- Moisture Sensitivity: Level 3 per J-STD-020
- Tape Reel :3000pcs

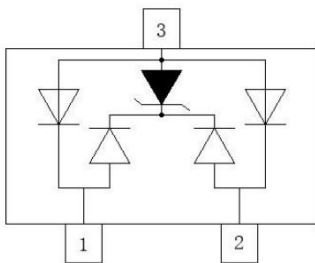
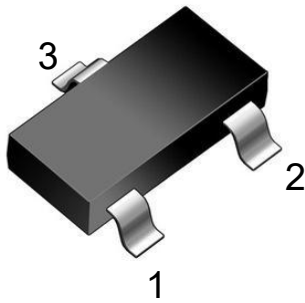
Appearance & Symbol**Applications**

- Automotive Applications
- CAN Bus
- Electronic Control Units
- Body Control Units
- ADAS Control Units
- PowerTrain Control Units

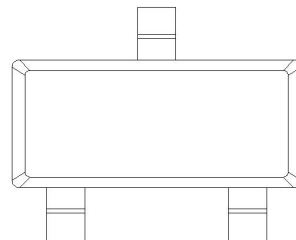
Marking Information

Absolute Maximum Ratings (T=25°C, RH=45%-75%, unless otherwise noted)

Parameters	Symbol	Value	Unit
Peak Pulse Power (tp=8/20µs waveform)	P _{PP}	80	W
Peak Pulse Current (8/20µs)	I _{PP}	5	A
ESD per IEC 61000-4-2 (Air) ESD per IEC 61000-4-2 (Contact)	V _{ESD}	±25 ±20	KV
Operating Temperature Range	T _J	-55 to +125	°C
Storage Temperature Range	T _{stg}	-55 to +150	°C

Electrical Characteristics (T=25°C, RH=45%-75%, unless otherwise noted)

Parameter	Symbol	Test Condition	Min	Typ	Max	Unit
Reverse Working Voltage	V _{RWM}				5	V
Reverse Breakdown Voltage	V _{BR}	I _R = 1mA	6		9	V
Reverse Leakage Current	I _R	V _R = 5V			0.2	µA
Clamping voltage	V _C	I _{PP} = 1A, T _P =8/20µs, pin1 or pin2 to pin3			9	V
Clamping voltage	V _C	I _{PP} =5A, T _P =8/20µs, pin1 or pin 2 to pin3			16	V
Junction capacitance	C _j	V _R =0V, f=1MHz, between I/O pins, between pin1 and pin2		0.3	0.4	pF
Junction capacitance	C _j	V _R =0V, f=1MHz, any I/O pin to ground, between pin1 or pin2 to pin3		0.6	0.8	pF

Typical Characteristics

FIG1: Power rating derating curve

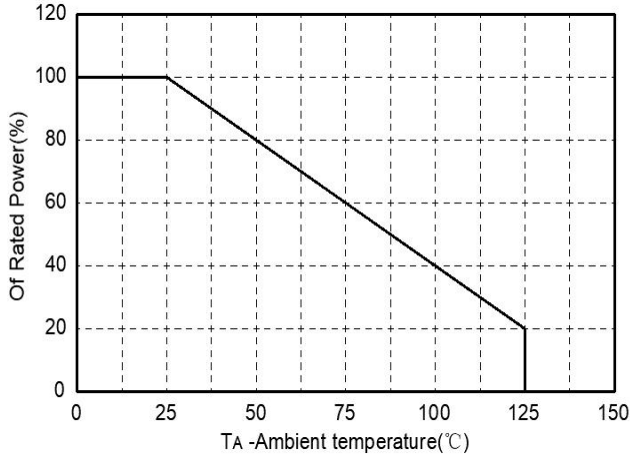

FIG2: pulse Waveform

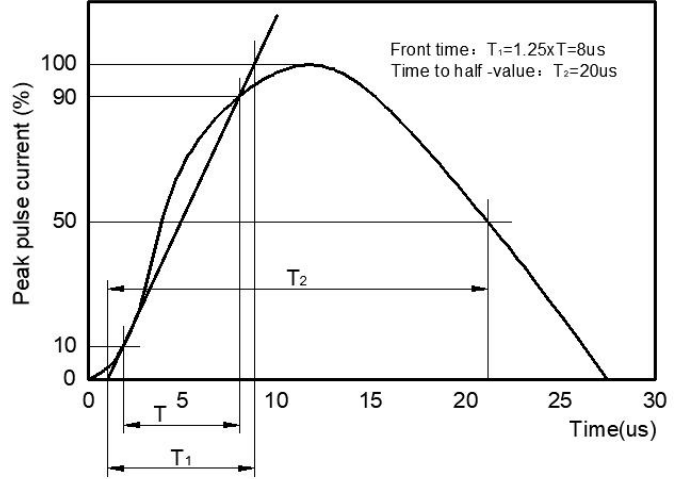

FIG3: Capacitance between terminals characteristics

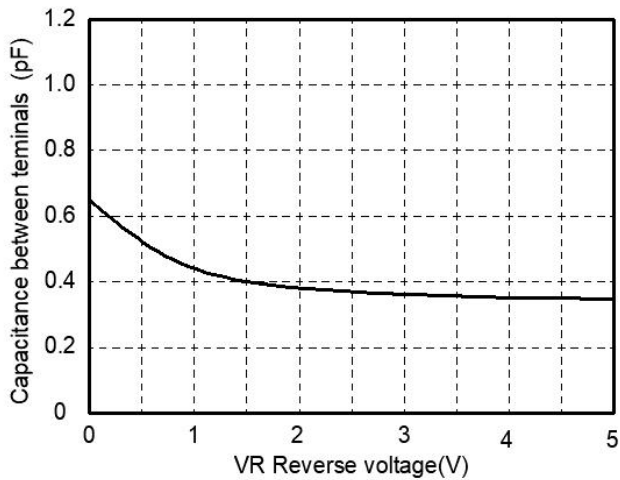
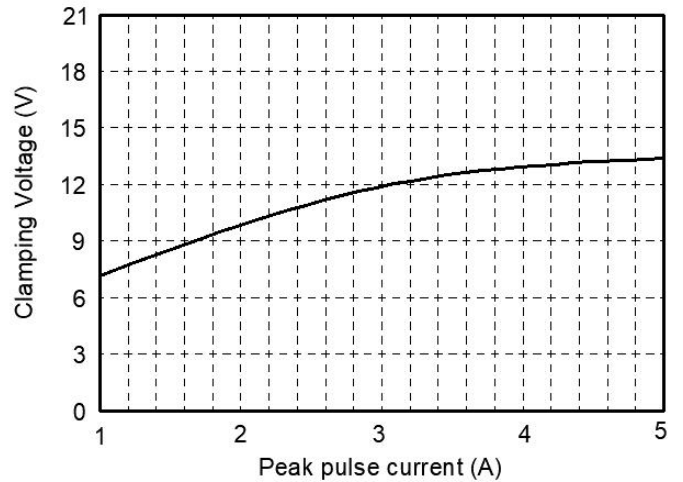
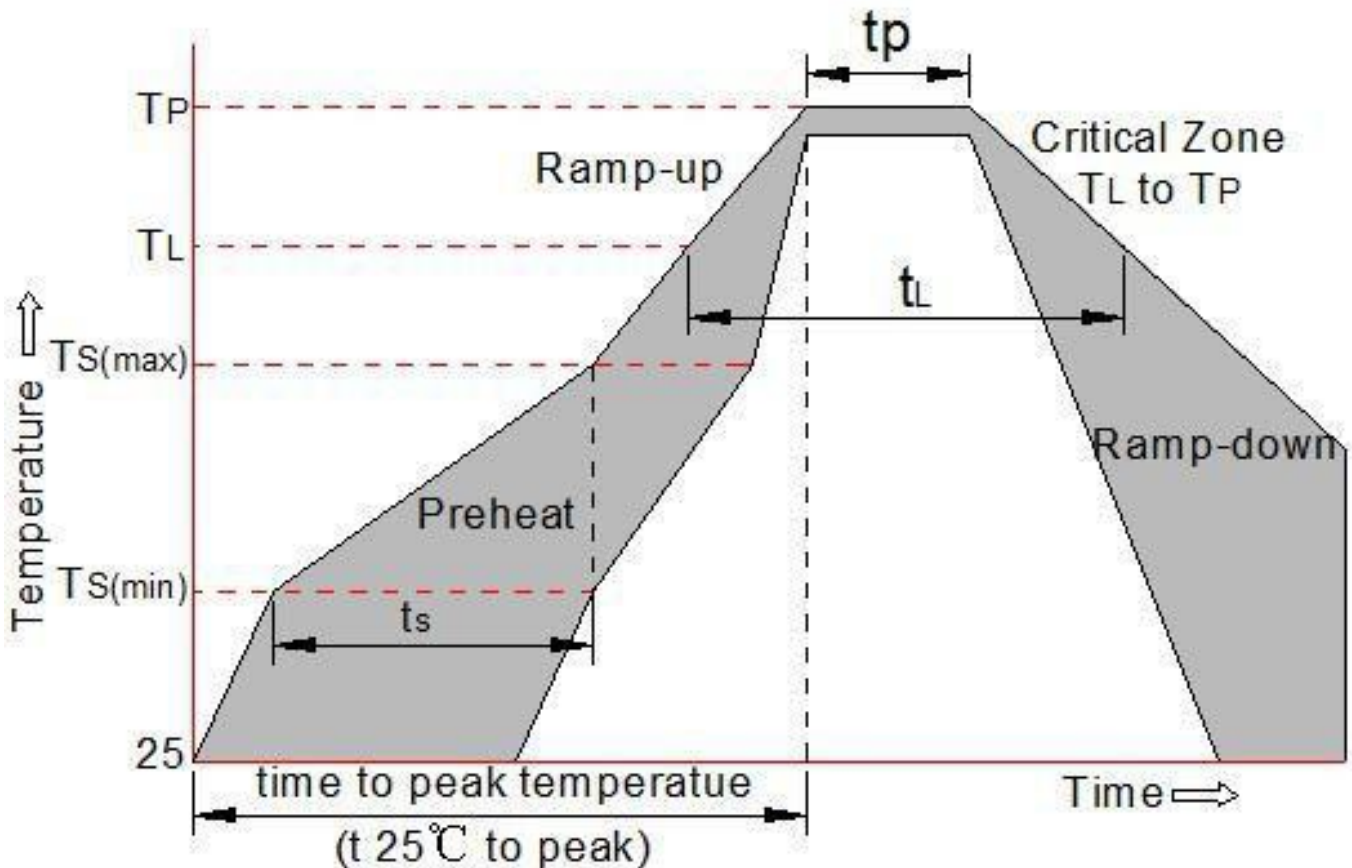

FIG4: Clamping Voltage vs. Peak Pulse Current



Soldering parameters

Reflow Condition		Pb-Free assembly (see as below)
Pre Heat	-Temperature Min ($T_{s(min)}$)	+150°C
	-Temperature Max($T_{s(max)}$)	+200°C
	-Time (Min to Max) (t_s)	60-180 secs.
Average ramp up rate (Liquid us Temp (T_L) to peak)		3°C/sec. Max
$T_{s(max)}$ to T_L - Ramp-up Rate		3°C/sec. Max
Reflow	-Temperature(T_L) (Liquid us)	+217°C
	-Temperature(t_L)	60-150 secs.
Peak Temp (T_p)		+260(+0/-5)°C
Time within 5°C of actual Peak Temp (t_p)		30 secs. Max
Ramp-down Rate		6°C/sec. Max
Time 25°C to Peak Temp (T_p)		8 min. Max
Do not exceed		+260°C



Package mechanical data

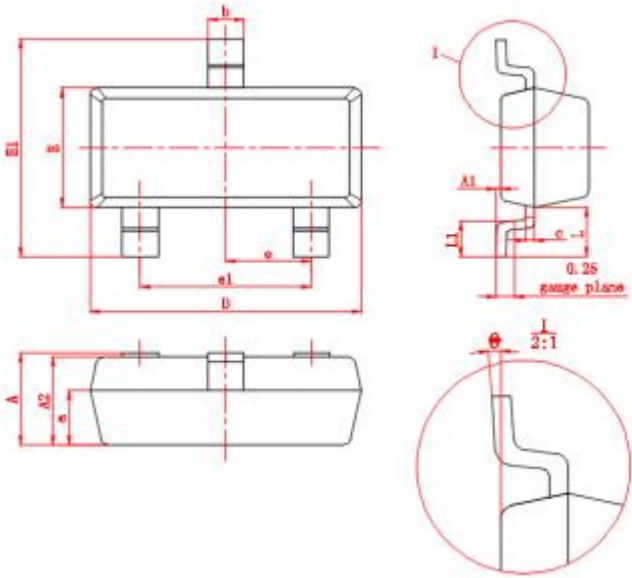

Symbol	Dimensional	
	Millimeters	
	min	max
A	0.9	1.15
A1	0	0.1
A2	0.9	1.05
a	(0.6)	
D	2.8	3.0
E	1.2	1.4
E1	2.25	2.55
e	(0.95)	
e1	1.8	2.0
b	0.3	0.5
c	0.08	0.15
L	(0.55)	
L1	0.3	0.5
θ	0°	8°

Suggested Land Pattern

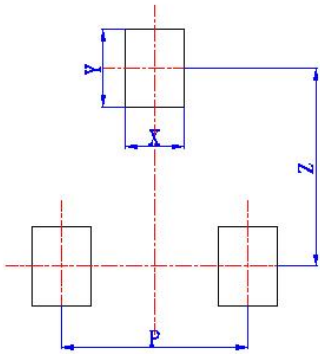

Symbol	Dimensional
	Millimeters
X	(0.6)
Y	(0.8)
Z	(2.02)
P	(1.9)

X-ON Electronics

Largest Supplier of Electrical and Electronic Components

Click to view similar products for [ESD Suppressors / TVS Diodes](#) category:

Click to view products by [SLKORMICRO](#) manufacturer:

Other Similar products are found below :

[60KS200C](#) [D18V0L1B2LP-7B](#) [D5V0F4U5P5-7](#) [NTE4902](#) [P4KE27CA](#) [P6KE11CA](#) [P6KE8.2A](#) [SA60CA](#) [SA64CA](#) [SMBJ12CATR](#)
[SMBJ33CATR](#) [SMBJ6.5A](#) [SMBJ8.0A](#) [ESD101-B1-02ELS](#) [E6327](#) [ESD112-B1-02EL](#) [E6327](#) [ESD7451N2T5G](#) [19180-510](#) [CPDT-5V0USP-](#)
[HF](#) [3.0SMCJ33CA-F](#) [3.0SMCJ36A-F](#) [HSPC16701B02TP](#) [JANTX1N6126A](#) [D3V3Q1B2DLP3-7](#) [D55V0M1B2WS-7](#) [SCM1293A-04SO](#)
[ESD200-B1-CSP0201](#) [E6327](#) [SM12-7](#) [CEN955](#) [W/DATA](#) [VESD12A1A-HD1-GS08](#) [CPDQC5V0-HF](#) [D1213A-01LP4-7B](#) [ESD101-B1-02EL](#)
[E6327](#) [AOZ8808DI-03](#) [5KP15A](#) [5KP48A](#) [5KP90A](#) [ESD3V3D7-TP](#) [15KPA36A-LF](#) [P4KE56CA](#) [P4KE68A](#) [P4KE91CATR](#) [P6KE120A](#)
[P6KE13CA](#) [P6KE43CA](#) [P6KE6.8CA](#) [P6KE8.2](#) [P6SMBJ20CA](#) [JANTX1N6072A](#) [SR2835ESKG](#) [SA90CA](#)