

NPN型功率晶体管

描述 / Descriptions

TO-220 塑封封装 NPN 半导体三极管。

Silicon NPN transistor in a TO-220 Plastic Package.

特征 / Features

与 TIP42 互补。

Complement to TIP42.

用途 / Applications

用于中功率线性开关放大。

Medium power linear switching applications.

极限参数 / Absolute Maximum Ratings(Ta=25°C)

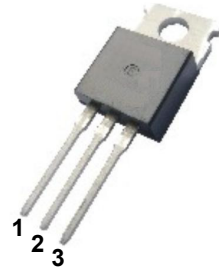

PIN1 : Base

PIN 2 : Collector

PIN 3 : Emitter

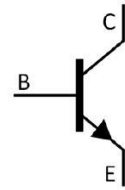

参数 Parameter	符号 Symbol	数值 Rating				单位 Unit
		TIP41	TIP41A	TIP41B	TIP41C	
Collector to Base Voltage	V_{CBO}	40	60	80	100	V
Collector to Emitter Voltage	V_{CEO}	40	60	80	100	V
Emitter to Base Voltage	V_{EBO}	5				V
Collector Current - Continuous	I_C	6				A
Peak Collector Current	I_{CP}	10				A
Base Current - Continuous	I_B	2				A
Collector Power Dissipation	P_C	2				W
Collector Power Dissipation	P_C ($T_c=25^\circ\text{C}$)	65				W
Junction Temperature	T_j	150				$^\circ\text{C}$
Storage Temperature Range	T_{sag}	-55~150				$^\circ\text{C}$

电性能参数 / Electrical Characteristics(Ta=25°C)

参数 Parameter	符号 Symbol	测试条件 Test Conditions	最小值 Min	典型值 Typ	最大值 Max	单位 Unit
Collector to Emitter Breakdown Voltage	V _{CEO}	TIP41	40			V
		TIP41A	60			
		TIP41B	80			
		TIP41C	100			
Collector Cut-Off Current	I _{CEO}	V _{CE} =30V I _B =0			0.7	mA
		V _{CE} =60V I _B =0				
Collector Cut-Off Current	I _{CES}	V _{CE} =40V V _{EB} =0			400	μA
		V _{CE} =60V V _{EB} =0				
		V _{CE} =80V V _{EB} =0				
		V _{CE} =100V V _{EB} =0				
Emitter Cut-Off Current	I _{EBO}	V _{EB} =5V I _C =0			1	mA
DC Current Gain	h _{FE(1)}	V _{CE} =4V I _C =3A	15		75	
	h _{FE(2)}	V _{CE} =4V I _C =0.3A	30			
Collector to Emitter Saturation Voltage	V _{CE(sat)}	I _C =6A I _B =0.6A			1.5	V
Base to Emitter Voltage	V _{BE}	I _C =6A V _{CE} =4V			2	V
Transition Frequency	f _T	V _{CE} =10V I _C =500mA	3			MHz

电参数曲线图 / Electrical Characteristic Curve

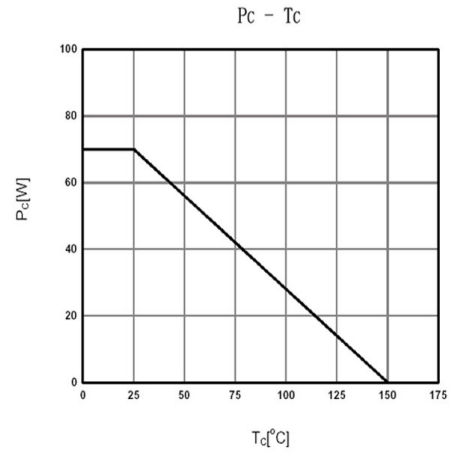
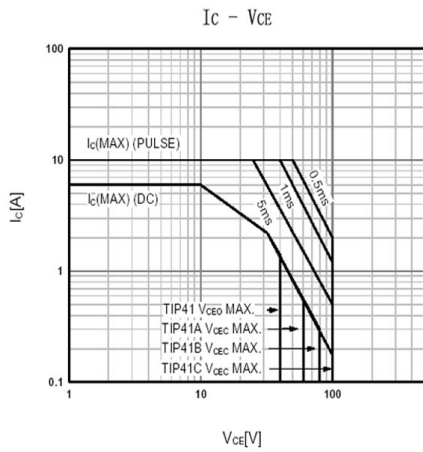
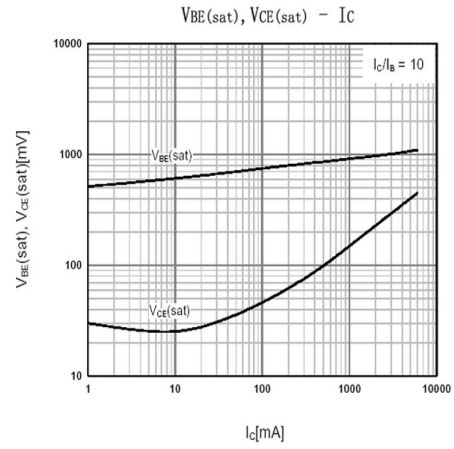
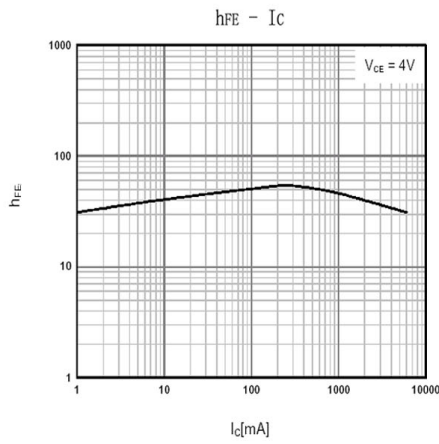

外形尺寸图 / Package Dimensions

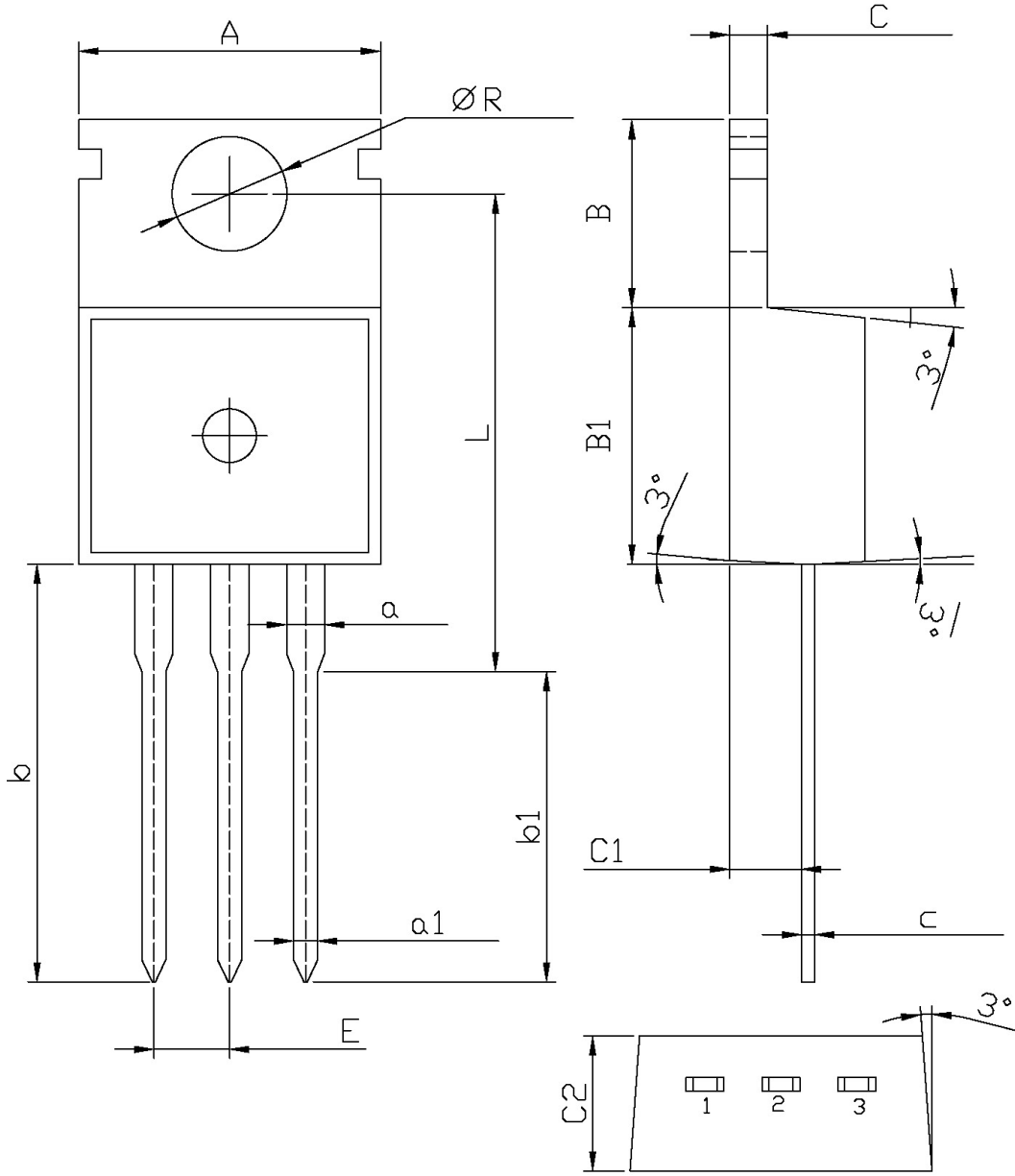

Symbol	Dimensions In Millimeters		Symbol	Dimensions In Millimeters	
	Min	Max		Min	Max
A	9.8	10.2	C	1.2	1.4
R	3.56	3.64	B	6.3	6.7
L	15.7	16.1	B1	9.0	9.4
b	12.6	13.6	C1	2.2	2.6
b1	9.6	10.6	a1	0.7	0.9
a	1.22	1.32	c	0.4	0.6
E	2.34	2.74	C2	4.3	4.7

X-ON Electronics

Largest Supplier of Electrical and Electronic Components

Click to view similar products for [Bipolar Transistors - BJT category](#):

Click to view products by [SLKORMICRO manufacturer](#):

Other Similar products are found below :

[BC559C](#) [MCH4017-TL-H](#) [MMBT-2369-TR](#) [BC546/116](#) [NJVMJD148T4G](#) [NTE16](#) [NTE195A](#) [IMX9T110](#) [2N4401-A](#) [2N6728](#) [2SA1419T-TD-H](#) [2SB1204S-TL-E](#) [2SC5488A-TL-H](#) [FMC5AT148](#) [2N2369ADCSM](#) [2N2907A](#) [2N3904-NS](#) [2N5769](#) [2SC4618TLN](#) [CPH6501-TL-E](#) [US6T6TR](#) [BAX18/A52R](#) [BC556/112](#) [IMZ2AT108](#) [MMST8098T146](#) [MCH6102-TL-E](#) [BC846B-13-F](#) [2N3879](#) [30A02MH-TL-E](#) [NTE13](#) [NTE282](#) [NTE323](#) [NTE350](#) [NTE81](#) [JANTX2N2920L](#) [JANSR2N2907AUB](#) [CMLT3946EG TR](#) [SNSS40600CF8T1G](#) [CMLT3906EG TR](#) [GRP-DATA-JANS2N2907AUB](#) [GRP-DATA-JANS2N2222AUA](#) [MMDT3946FL3-7](#) [2N4240](#) [JANS2N3019](#) [MSB30KH-13](#) [2N2221AUB](#) [2SD1815T-TL-E](#) [2N6678](#) [2N2907Ae4](#) [JAN2N3507](#)