

PNP型功率晶体管

描述 / Descriptions

TO-220 塑封封装 PNP 半导体三极管。

Silicon PNP transistor in a TO-220 Plastic Package.

特征 / Features

与 TIP41 互补。

Complement to TIP41.

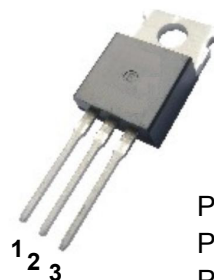

PIN1 : Base
PIN 2 : Collector
PIN 3 : Emitter

用途 / Applications

用于中功率线性开关放大。

Medium power linear switching applications.

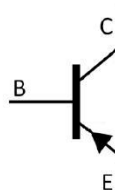

极限参数 / Absolute Maximum Ratings(Ta=25°C)

参数 Parameter	符号 Symbol	数值 Rating				单位 Unit
		TIP42	TIP42A	TIP42B	TIP42C	
Collector to Base Voltage	V_{CBO}	-40	-60	-80	-100	V
Collector to Emitter Voltage	V_{CEO}	-40	-60	-80	-100	V
Emitter to Base Voltage	V_{EBO}	-5.0				V
Collector Current - Continuous	I_C	-6.0				A
Peak Collector Current	I_{CP}	-10				A
Base Current - Continuous	I_B	-2.0				A
Collector Power Dissipation	P_C	2.0				W
Collector Power Dissipation	$P_C(T_c=25^\circ\text{C})$	65				W
Junction Temperature	T_j	150				°C
Storage Temperature Range	T_{sag}	-55~150				°C

电性能参数 / Electrical Characteristics(Ta=25°C)

参数 Parameter	符号 Symbol	测试条件 Test Conditions	最小值 Min	典型值 Typ	最大值 Max	单位 Unit	
Collector to Emitter Breakdown Voltage	V _{CEO}	TIP42	-40			V	
		TIP42A	-60				
		TIP42B	-80				
		TIP42C	-100				
Collector Cut-Off Current	I _{CEO}	TIP42 TIP42A	V _{CE} =-30V	I _B =0		-0.7	mA
		TIP42B TIP42C	V _{CE} =-60V	I _B =0			
Collector Cut-Off Current	I _{CES}	TIP42	V _{CE} =-40V	V _{EB} =0		-400	μA
		TIP42A	V _{CE} =-60V	V _{EB} =0			
		TIP42B	V _{CE} =-80V	V _{EB} =0			
		TIP42C	V _{CE} =-100V	V _{EB} =0			
Emitter Cut-Off Current	I _{EBO}	V _{EB} =-5.0V	I _C =0			-1.0	mA
DC Current Gain	h _{FE(1)}	V _{CE} =-4.0V	I _C =-3.0A	15		75	
	h _{FE(2)}	V _{CE} =-4.0V	I _C =-0.3A	30			
Collector to Emitter Saturation Voltage	V _{CE(sat)}	I _C =-6.0A	I _B =-0.6A			-1.5	V
Base to Emitter Voltage	V _{BE}	I _C =-6.0A	V _{CE} =-4.0V			-2.0	V
Transition Frequency	f _T	V _{CE} =-10V	I _C =-500mA	3.0			MHz

电参数曲线图 / Electrical Characteristic Curve

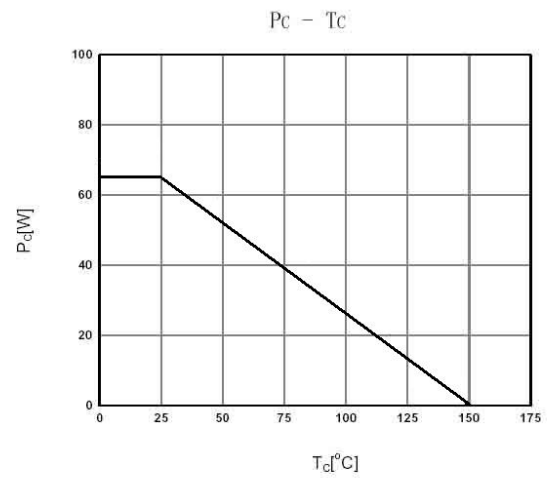
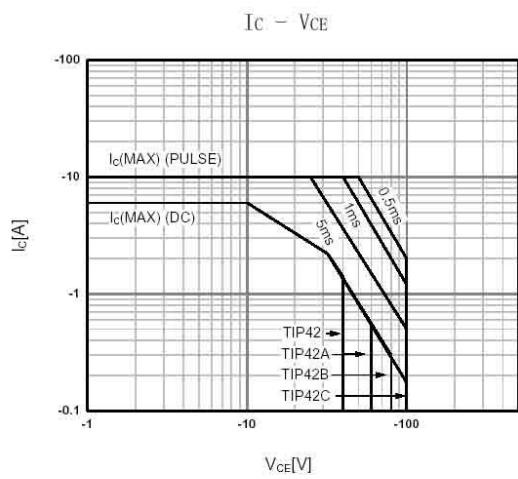
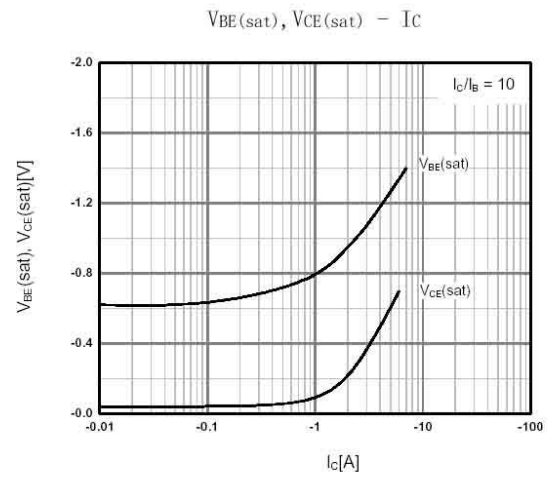
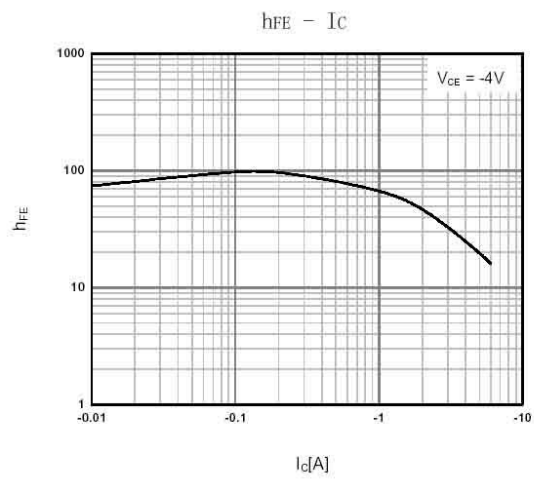

外形尺寸图 / Package Dimensions

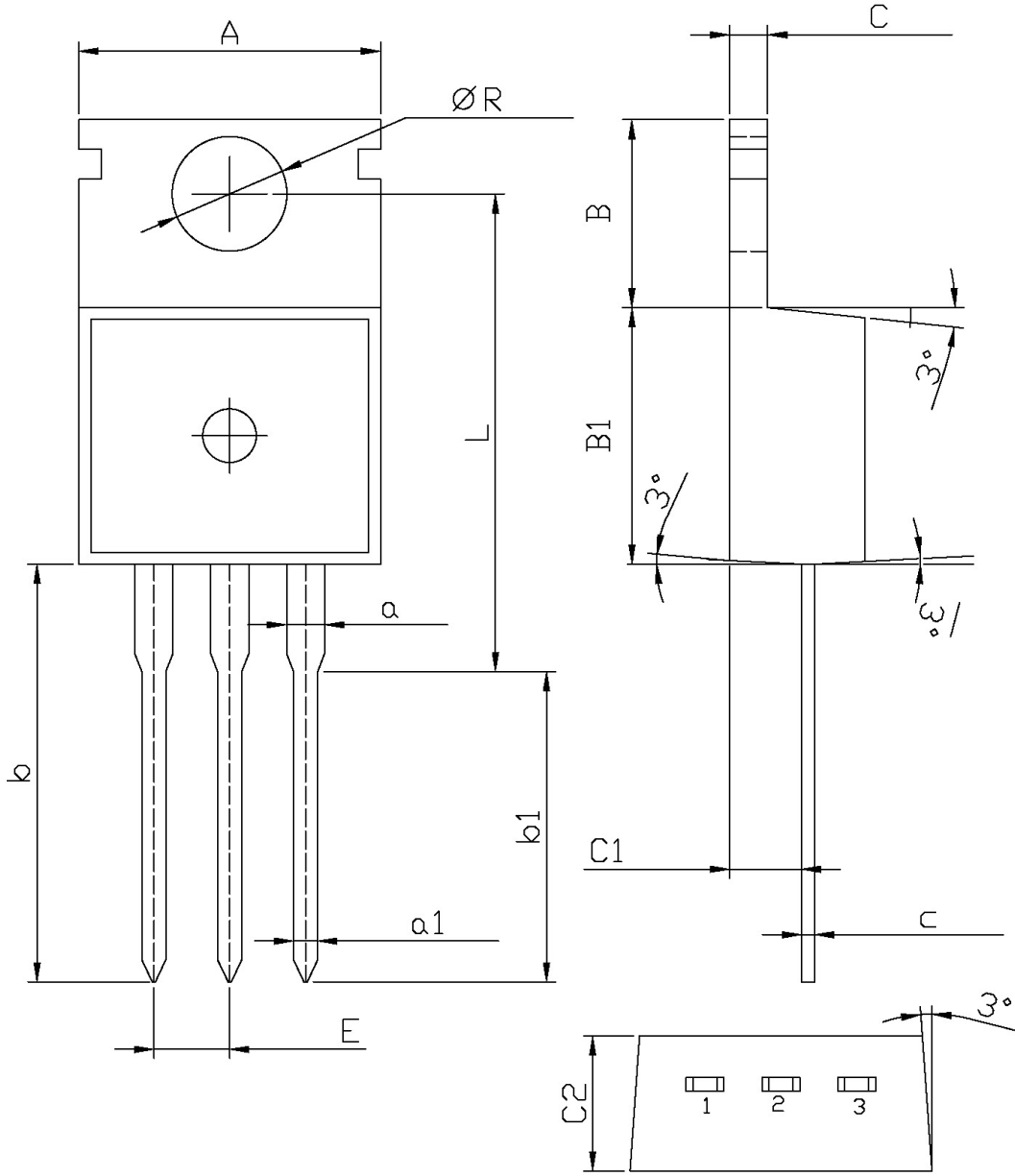

Symbol	Dimensions In Millimeters		Symbol	Dimensions In Millimeters	
	Min	Max		Min	Max
A	9.8	10.2	C	1.2	1.4
R	3.56	3.64	B	6.3	6.7
L	15.7	16.1	B1	9.0	9.4
b	12.6	13.6	C1	2.2	2.6
b1	9.6	10.6	a1	0.7	0.9
a	1.22	1.32	c	0.4	0.6
E	2.34	2.74	C2	4.3	4.7

X-ON Electronics

Largest Supplier of Electrical and Electronic Components

Click to view similar products for [Bipolar Transistors - BJT category](#):

Click to view products by [SLKORMICRO manufacturer](#):

Other Similar products are found below :

[BC559C](#) [MCH4017-TL-H](#) [MMBT-2369-TR](#) [BC546/116](#) [NJVMJD148T4G](#) [NTE16](#) [NTE195A](#) [IMX9T110](#) [2N4401-A](#) [2N4403](#) [2N6728](#)
[2SA1419T-TD-H](#) [2SA2126-E](#) [2SB1204S-TL-E](#) [FMC5AT148](#) [2N2369ADCSM](#) [2N2907A](#) [2N3904-NS](#) [2N5769](#) [2SC4618TLN](#) [CPH6501-](#)
[TL-E](#) [MCH4021-TL-E](#) [Jantx2N5416](#) [US6T6TR](#) [BAX18/A52R](#) [BC556/112](#) [IMZ2AT108](#) [MMST8098T146](#) [UMX21NTR](#) [MCH6102-TL-E](#)
[TTA1452B,S4X\(S](#) [2N3879](#) [NTE13](#) [NTE282](#) [NTE323](#) [NTE350](#) [NTE81](#) [JANTX2N2920L](#) [JANTX2N3735](#) [JANSR2N2222AUB](#)
[CMLT3946EG TR](#) [SNSS40600CF8T1G](#) [CMLT3906EG TR](#) [GRP-DATA-JANS2N2907AUB](#) [GRP-DATA-JANS2N2222AUA](#)
[MMDT3946FL3-7](#) [2N4240](#) [MSB30KH-13](#) [2N2221AUB](#) [2SD1815T-TL-E](#)