



FEATURES AND BENEFITS

20W Open Frame and PCB-mount Power Supply

1.6" x 3.38" x 1.0" Package

Universal Input 90-264VAC

<0.1W No Load Input Power

Approved to CSA/EN/IEC/UL62368-1

Meets Heavy Industrial and IEC60601-1-2
4th Edition Levels of EMC

Approved to CSA/EN/IEC/UL60601-1, 3rd Edition

E-cap Life of >7 Years

>1,000,000 Hours MTBF

3 Year Warranty

Meets Class B Radiated & Conducted EMI, with
Margin

Note: *Consult Factory for compliance information.



MODEL SELECTION

Model Number ²	Volts	Rated Current	Output Power	Ripple & Noise ¹	Line Regulation	Load Regulation	Input Class/Termination	Output Termination
GB20S05K01	5.0V	3.0A	15W	75mV pk-pk	±1%	±5%	Class I (Grounded) input, 3-pin AMP/Molex type connector Change "K" to "C" for class II input	4-pin AMP/Molex type connector for "K" and "C" versions
GB20S07K01	7.5V	2.0A	15W	75mV pk-pk	±1%	±5%		
GB20S09K01	9.0V	2.0A	18W	90mV pk-pk	±1%	±5%		
GB20S12K01	12.0V	1.5A	18W	120mV pk-pk	±1%	±5%	Change "K" to "P" for PCB mount pins, class I input Change "K" to "V" for PCB mount pins", class II input	PCB mount pins for "P" and "V" versions
GB20S15K01	15.0V	1.2A	18W	120mV pk-pk	±1%	±5%		
GB20S24K01	24.0V	0.8A	20W	240mV pk-pk	±1%	±5%		
GB20S48K01	48.0V	0.4A	20W	480mV pk-pk	±1%	±5%		

Note: 1. Ripple & noise are measured at 20MHz of bandwidth by using a 12" twisted pair-wire terminated with a 0.1uF & 47uF parallel capacitor.

2. Other output voltages available, consult factory.

3. All specifications are typical at 230VAC, full load, at 25°C ambient unless noted.

INPUT

Input Voltage and Frequency	100-240VAC, ±10%, 47-63Hz, 1Ø
Input Current	115VAC: 0.5A, 230VAC: 0.2A
Inrush Current	264VAC, cold start: will not exceed 40A peak
Input Fuses	3.15A, 250VAC fuse in both line and neutral
Earth Leakage Current (Input to Ground)	<500µA@264VAC, 60Hz, NC <1mA@264VAC, 60Hz, SFC
Earth Leakage Current (Output to Ground)	<100µA@264VAC, 60Hz, NC <500µA@264VAC, 60Hz, SFC
Efficiency	>88%, typical
Power Factor	0.9, min., 230VAC, 80-100% load vector, 25°C ambient

Note: All specifications are typical at 230VAC input, full load, at 25°C ambient unless noted.

OUTPUT

Turn On Time	<700ms
Hold-Up Time	20ms/100VAC at full load
Output Power	15W-20W continuous – See models chart for specific voltage model ratings
Output Voltage	See models chart
Transient Response	500µs resp.time for return to w/in 0.5% of final value for any 50% load step from 5% to 100% of rated load, Δi/Δt<0.2A/µs Max voltage deviation is +/-3.5%
Regulation	See models chart

Note: All specifications are typical at 230VAC input, full load, at 25°C ambient unless noted.



PROTECTION

Overtemperature Protection	Will shutdown upon an overtemperature condition, Auto-recovery
Overload Protection	130% to 160% of rated output current value, Hiccup mode
Short Circuit Protection	Hiccup mode
Overvoltage Protection	120% to 150% of nominal output voltage, Hiccup Mode

RELIABILITY

MTBF	>1,000,000 hours, full load, 110 & 220VAC input, 25°C amb., per telcordia 332 issue 6, stress method
E-cap Life	>7 year life based on calculations at 115VAC/60Hz & 230VAC/50Hz, ambient 25°C at 24 hrs per day, 365 days/year, 6 power up cycles per day

ISOLATION SPECIFICATIONS

Isolation	Input-Output	: 4000VAC (2 MOPP)
	Input-Ground	: 1500VAC (1 MOPP)
	Output-Ground	: 1500VAC (1 MOPP)
Isolation Resistance	I/P-O/P, I/P-FG, O/P-FG: TBD	

ENVIRONMENT

Operating Temperature	-25 ~ +70°C, see derating curve for operation above 40°C
Storage Temperature	-40°C ~ +85°C
Cooling	Convection
Relative Humidity	5% to 90%, Non-condensing
Vibration	Operating: 0.003g/Hz, 1.5grms overall, 3 axes, 10 min/axis, 1-500Hz Non-Oper.: random waveform, 3 minutes per axis, 3 axes and sine waveform, Vib. frequency/acceleration: 10-500Hz/1g, sweep rate of 1 octave/minutes, vibration time of 10 sweeps/axes, 3 axes
Shock	Operating: Half-sine, 20gpk, 10ms, 3 axes, 6 shocks total Non-Operating: Half-sine waveform, impact acceleration of 50G, pulse duration of 6ms, Number of shocks: 3 for each of the three axis
Dimensions	41 x 86 x 25mm 1.6 x 3.38 x 1.0 inch
Weight	120g

Note: Same dimensions for PCB & Pin Variants.

SAFETY

ITE/Industrial Safety	EN/IEC/UL62368-1
Medical Safety	EN/IEC/UL60601-1, 3 rd edition

EMI/EMC COMPLIANCE

Conducted Emissions	EN55032, EN55011/CISPR11 Class B, FCC Part 15.107, Class B: 6db margin type, at 115 and 230VAC
Radiated Emissions	EN55032, EN55011/CISPR11 Class B, FCC Part 15.109, Class B: 3db margin type, at 115 and 230VAC
Electro-Static Discharge (ESD) Immunity on Power Ports	EN55024/IEC61000-4-2, Level 4: +/- 8kV contact, +/- 15kV air, Criteria A IEC60601-1-2, 4 th edition, Table 4
Radiated RF EM Fields Susceptibility	EN55022/EN61000-4-3, 10V/m, 80MHz-2.7GHz, 80% AM at 1kHz IEC60601-1-2, 4 th edition, Table 4
Electrical Fast Transients (EFT)/Bursts	EN55024/IEC61000-4-4, Level 4, +/- 4.4kV, 100Khz rep rate, 40A, Criteria A IEC60601-1-2, 4 th edition, Table 5
Surges, Line to Line (Diff Mode) and Line to GND (CMN Mode)	EN55024/IEC61000-4-5, Level 4, +/-2kV DM, +/-4kV CM, Criteria A Surpasses IEC60601-1-2, 4 th edition requirements
Conducted Disturbances Induced by RF Fields	EN55022/IEC61000-4-6, 3.6V/m – Level 4, (0.15 to 80Mhz; and 12V/m) in ISM and amateur radio bands between 0.15Mhz and 80Mhz, 80% AM at 1KHz IEC60601-1-2, 4 th edition, Table 5
Rated Power Frequency Magnetic Fields	EN55024/IEC1000-4-8, Level 4: 30 A/m, 50/60Hz IEC60601-1-2, 4 th edition, Table 4
Voltage Interruptions, Dips, Sags & Surges	EN55024/IECEN61000-4-11: --100% dip for 10 ms, at 0, 45, 90, 135, 180, 225, 270 and 315 degrees, 100% dip for 20ms, 0 deg., Criteria A --100% dip for 5000ms (250/300 cycles), Criteria B --60% dip for 100ms, Criteria B --30% dip for 500ms, Criteria A IEC60601-1-2, 4 th edition, Table 5
Harmonic Current Emissions	EN55011/EN61000-3-2, Class A
Flicker Test	EN61000-3-3

Note: 1. The power supply is considered a component which will be installed into a final equipment. The final equipment must be re-confirmed that it still meets EMC directives.
2. All specifications are typical at nominal input, full load, at 25°C ambient unless noted. Consult factory for information regarding testing for or usage under special environments.



DERATING CURVE

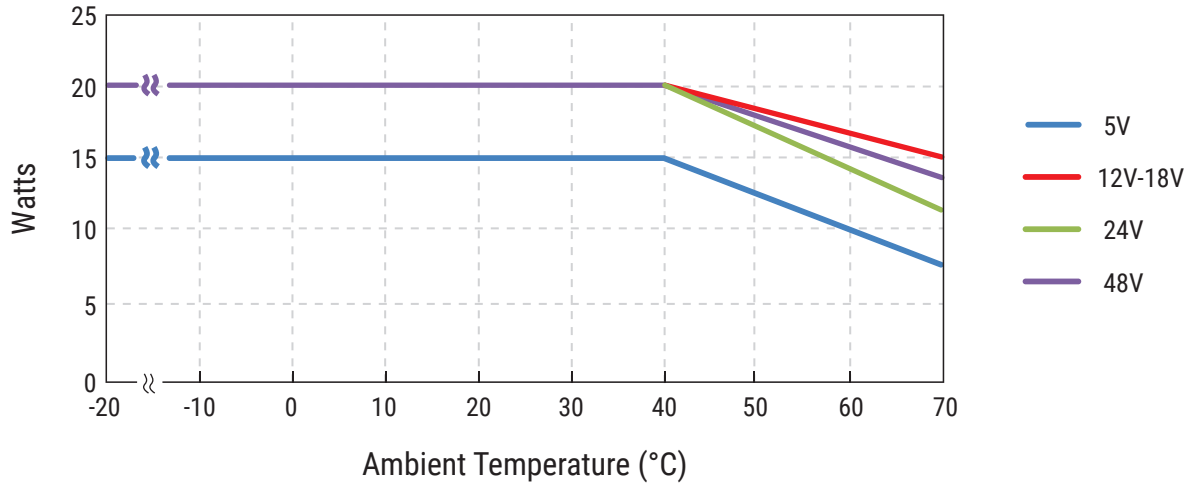

MECHANICAL DRAWING

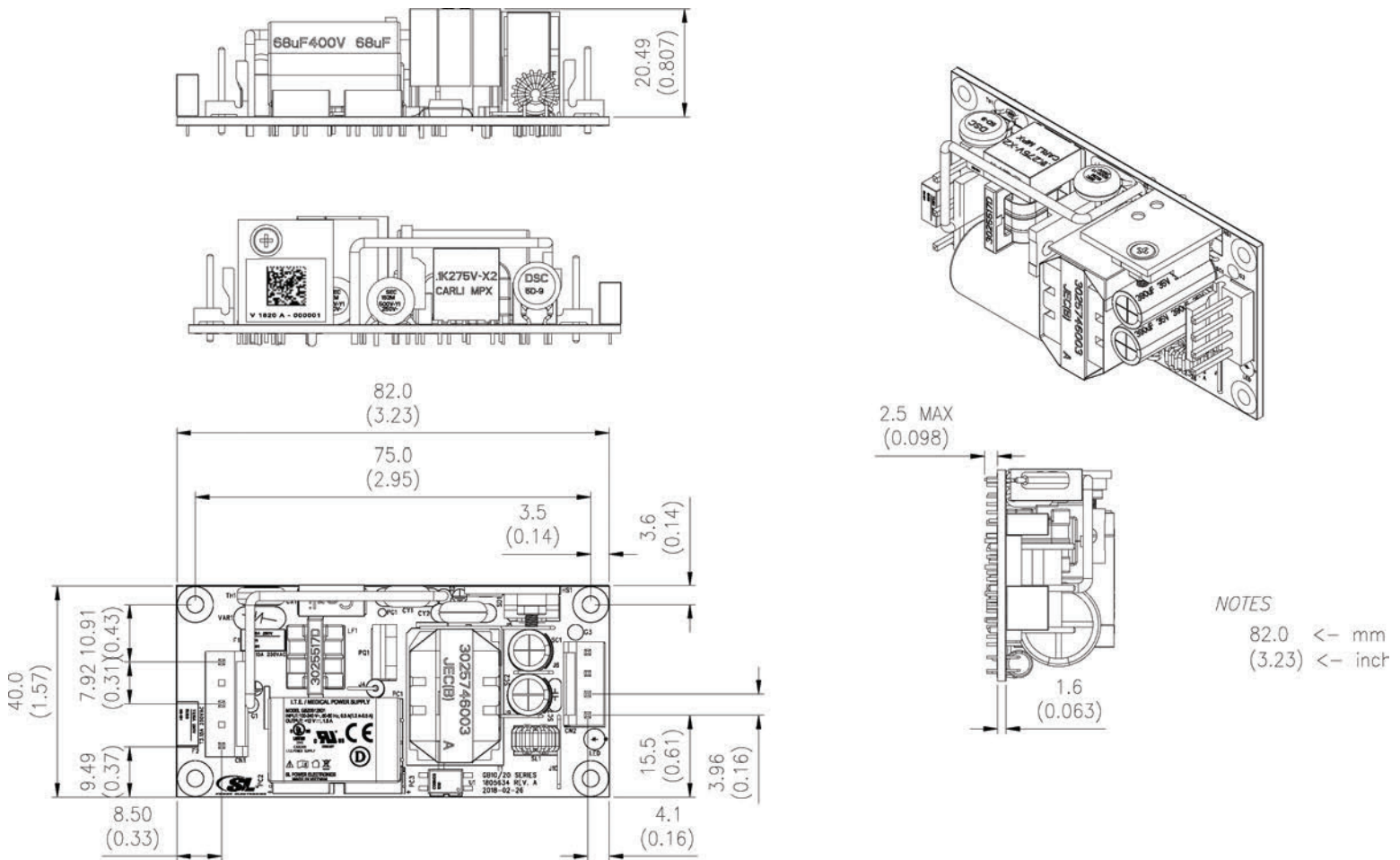

NOTES
82.0 ← mm
(3.23) ← inch

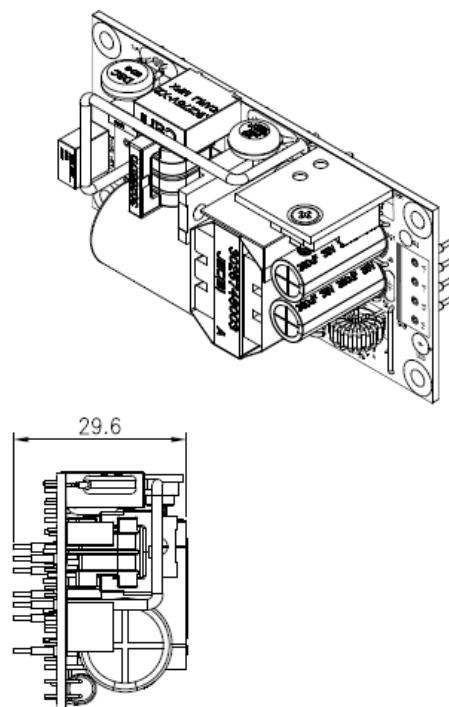
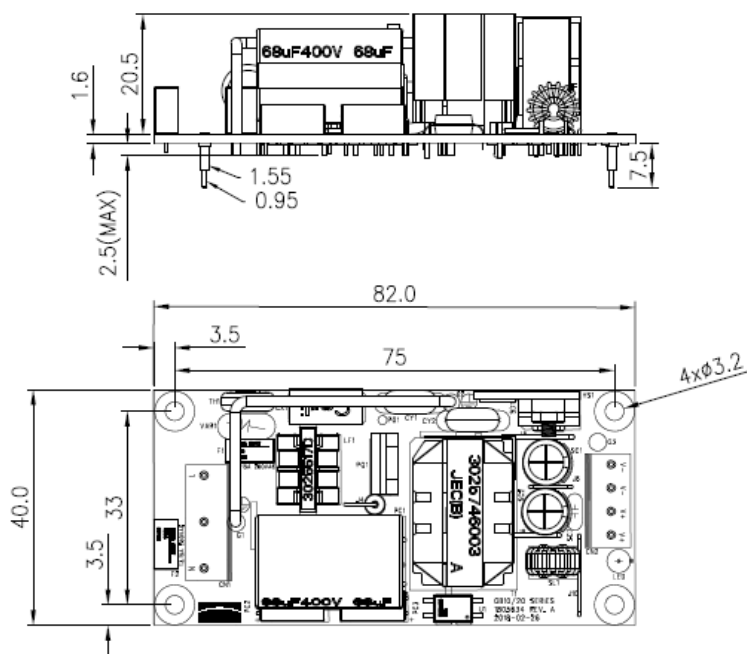

CONNECTOR AND TERMINATION INFORMATION

Input Connections				Output Connections	
Version	Connector Pinout	Ground	Connector Type/Part No.	Connector Pinout	Connector Type/Part No.
Open Frame: "K", "C"	Pin 1: AC LINE Pin 2: N/C Pin 3: GROUND Pin 4: N/C Pin 5: AC NEUTRAL		Connector: TE/AMP P/N 640445-5 Mating Connector: TE/ AMP P/N 640250-5 Pins= 770476-1	Pin 1: +Vout Pin 2: +Vout Pin 3: -Vout Pin 4: -Vout	Connector: TE/AMP P/N 640445-4 Mating Connector: TE/AMP P/N 640250-4, Pins= 770476-1
PCB Mount: "P", "V"	Pin 1: AC Line Pin 2: AC Neutral	PG: AC Ground (N/A on "V" version)	Pencom PI3207 or equivalent	Pin 4: +Vout Pin 5: +Vout Pin 6: -Vout Pin 7: -Vout	Pencom PI3207 or equivalent

X-ON Electronics

Largest Supplier of Electrical and Electronic Components

Click to view similar products for [Switching Power Supplies](#) category:

Click to view products by [SL Power](#) manufacturer:

Other Similar products are found below :

[70841011](#) [73-551-0005](#) [73-551-0048](#) [PS3E-B12F](#) [PS3E-E12F](#) [AAD600S-4-OP](#) [R22095](#) [KD0204](#) [9021](#) [LDIN100150](#) [LPM000-BBAR-01](#)
[LPX17S-C](#) [EVS57-10R6/R](#) [FP80](#) [FRV7000G](#) [22929](#) [PS3E-F12F](#) [CQM1IA121](#) [40370121900](#) [VI-PU22-EXX](#) [40370121910](#) [LDIN5075](#)
[LPM615-CHAS](#) [LPX140-C](#) [09-160CFG](#) [70841025](#) [VPX3000-CBL-DC](#) [LPM000-BBAR-05](#) [LPM000-BBAR-08](#) [LPM124-OUTA1-48](#)
[LPM000-BBAR-07](#) [LPM109-OUTA1-10](#) [LPM616-CHAS](#) [08-30466-1055G](#) [08-30466-2175G](#) [08-30466-2125G](#) [DMB-EWG](#) [TVQF-1219-](#)
[18S](#) [6504-226-2101](#) [CQM1IPS01](#) [SP-300-5](#) [CQM1-IPS02](#) [VI-MUL-ES](#) [22829](#) [08-30466-0065G](#) [VI-RU031-EWWX](#) [08-30466-0028G](#) [VI-](#)
[LUL-EU](#) [EP3000AC48INZ](#) [VP-C2104853](#)