



Industrial

FEATURES AND BENEFITS

Compact Size: 6.5" x 2.8" x 1.5"

Meets DoE Efficiency Level VI and EU CoC Version 5, Tier 2 Requirements

- No Load Input Power
- Average Efficiency

Up to 150W of AC-DC Power

>10 Years E-Cap Life

Universal Input Range 90-264Vac

IP22 Rated Enclosure

Meets EN55015/CISPR15, CISPR22, CISPR32, FCC Part 15.109 Class B Conducted & Radiated Emissions, with 6db Margin

Approved to EN/CSA/IEC/UL62368-1

3 Year Warranty

RoHS/REACH Compliant

Blue LED Indicator



MODEL SELECTION

Model Number	Volts	Output Current	Output Power	Ripple & Noise ¹	Line Regulation	Load Regulation	Output Cable & Connector	Input Configuration
TE150A1251F01	12.0V	12.5A	150W	120mV pk-pk	±1%	±5%	6 pin Molex Type ² 2.5 x 5.5 x 9.5mm Str. Barrel Type, center (+)	Class I Desktop, IEC60320 C14 Receptacle
TE150A1551F01	15.0V	10.0A	150W	150mV pk-pk	±1%	±5%		
TE150A1851F01	18.0V	8.33A	150W	180mV pk-pk	±1%	±5%		
TE150A2451F01	24.0V	6.25A	150W	240mV pk-pk	±1%	±5%		
TE150A4803F01	48.0V	3.20A	150W	480mV pk-pk	±1%	±5%		
TE150A1251N01	12.0V	12.5A	150W	120mV pk-pk	±1%	±5%	6 pin Molex Type ² 2.5 x 5.5 x 9.5mm Str. Barrel Type, center (+)	Class II Desktop, IEC60320 C8 Receptacle
TE150A1551N01	15.0V	10.0A	150W	150mV pk-pk	±1%	±5%		
TE150A1851N01	18.0V	8.33A	150W	180mV pk-pk	±1%	±5%		
TE150A2451N01	24.0V	6.25A	150W	240mV pk-pk	±1%	±5%		
TE150A4803N01	48.0V	3.20A	150W	480mV pk-pk	±1%	±5%		
TE150A1251Q01	12.0V	12.5A	150W	120mV pk-pk	±1%	±5%	6 pin Molex Type ² 2.5 x 5.5 x 9.5mm Str. Barrel Type, center (+)	Class II Desktop, IEC60320 C18 Receptacle
TE150A1551Q01	15.0V	10.0A	150W	150mV pk-pk	±1%	±5%		
TE150A1851Q01	18.0V	8.33A	150W	180mV pk-pk	±1%	±5%		
TE150A2451Q01	24.0V	6.25A	150W	240mV pk-pk	±1%	±5%		
TE150A4803Q01	48.0V	3.20A	150W	480mV pk-pk	±1%	±5%		

- Notes:**
1. Measured at the output connector, with noise probe directly across output and load, terminated with 0.1µF ceramic and 47µF low ESR capacitors.
 2. Molex p/n 39-01-2060 or equivalent. See outline drawing for pinout information.
 3. For Input Class I models: For AC GND connected to output common (-), insert a "B" in the part number where the "A" is located (TE120B1251F01).
 4. All specifications are typical at nominal input, full load, at 25°C ambient unless noted.



INPUT

AC Input	100-240Vac, $\pm 10\%$, 47-63Hz, 1 \emptyset
Input Current	115Vac: 1.6A, 230Vac: 0.8A
Inrush Current	230Vac, cold start: will not exceed 70A pk
Input Fuses	F1, F2: 3.15A/250Vac fuses (line & neutral lines) provided on all models
Leakage Current	Input-GND: $< 500\mu\text{A}@264\text{Vac}$, 60Hz, NC Output-GND: $< 4\text{mA}@264\text{Vac}$, 60Hz, NC Enclosure Leakage: TBDuA
Efficiency	Meets US DoE Efficiency Level VI, EU CoC Version 5, Tier 2 average efficiency levels
No Load Input Power	$< 0.150\text{W}$ surpassing DoE Efficiency Level VI and EU CoC Version 5, Tier 2 Requirements

PROTECTION

Overtemperature Protection	Will shutdown upon an over-temperature condition, auto-recovery
Overload Protection	130 to 180% of rating, Hiccup Mode
Short Circuit Protection	Hiccup Mode, auto recovery
Overvoltage Protection	115 to 130% of output voltage (max. 60V on 48V model), latching, recycle AC power to recover

SAFETY

Safety Standards	EN/CSA/IEC/UL62368-1
Shock	Operating: Half-sine, 20gpk, 10mS, 3 axes, 6 shocks total Non-Operating: Half-sine waveform, impact acceleration of 50G, Pulse duration of 6 mS Number of shocks: 3 for each of the three axis
Safety Drop Test	1.4m from table top to wooden platform, 5 faces (face with the output cord not needed)

ISOLATION SPECIFICATIONS

Isolation	Input-Output: 3,000Vac Input-Ground: 1,500Vac Output-Ground: 500Vac
-----------	---

OUTPUT

Hold-Up Time	20mS min., at full Load, 100Vac input
Turn On Time	Less than 1 sec @115Vac, full load
Output Power	150W continuous – See models chart for specific voltage model ratings
Output Voltage	See models chart on pg 1
Ripple and Noise	See models chart on pg 1
Transient Response	500 μs response time for return to within 0.5% of final value for any 50% load step over the range of 5% to 100% of rated load, $\Delta i/\Delta t < 0.2\text{A}/\mu\text{s}$. Max voltage deviation is $\pm 3.5\%$ of final value

RELIABILITY

MTBF	$> 250,000$ hours, full load, 115 & 230Vac input, 25°C amb., Telcordia SR-332 Issue 3
E-Cap Life	> 10 year life based on calculations at 115Vac/60Hz & 230Vac/50Hz, ambient 25°C at 24 hrs per day, 365 days/year, 6 power up cycles per day. (80% load on 12V models)

ENVIRONMENT

Operating Temperature	-20°C to +70°C. Derate above 50°C Ripple & Noise = 2% from -20°C to 0°C
Temperature Derating	Derate output power above 40°C to TBD at 50°C
Storage Temperature	-40°C to +85°C
Altitude	Operating: to 5000m (derate to TBD temp. above 3000m) Non-operating: -500 to 40,000 ft.
Relative Humidity	5% to 95%, non-condensing
Vibration	Operating: 0.003g/Hz, 1.5grms overall, 3 axes, 10min/axis, 1-500Hz. Non-Oper.: random waveform, 3 minutes per axis, 3 axes and Sine waveform, Vib. frequency/acceleration: 10-500Hz/1g, sweep rate of 1 octave/minutes, Vibration time of 10 sweeps/axes, 3 axes
Case Temperature	Case Temperatures are within regulatory guidelines Care should be taken to avoid prolonged contact with skin or other heat sensitive surfaces
Dimensions	W: 6.49" x L: 1.45" x H: 2.83" Case
Weight	700g

Notes: All specifications are typical at nominal input, full load, at 25°C ambient unless noted.



EMI/EMC COMPLIANCE

Conducted Emissions	EN55015/CISPR15:2013 Class B, CISPR22 2006 Class B, CISPR32 Class B, FCC Part 15.107, Class B: 6db margin type, at 115 and 230Vac
Radiated Emissions	EN55022/CISPR22 Class B, CISPR32 Class B, FCC Part 15.109, Class B: 3db margin type, at 115 and 230Vac
Common Mode Noise	High Frequency (100kHz-20MHz): <40mA pk-pk
Electro-Static Discharge (ESD) Immunity on Power ports	EN55024/IEC61000-4-2, Level 4: +/- 8kV contact, +/- 15kV air, Criteria A
Radiated RF EM Fields Susceptibility	EN55022/EN61000-4-3, 10V/m, 80MHz-2.7GHz, 80% AM at 1kHz
Electrical Fast Transients (EFT) /Bursts	EN55024/IEC61000-4-4, Level 4, +/- 4.4kV, 100Khz rep rate, 40A, Criteria A
Surges, Line to Line (Diff Mode) and Line to GND (CMN Mode)	EN55024/IEC61000-4-5, Level 4, +/-2.2kV DM, +/-4.4kV CM, Criteria A
Conducted Disturbances induced by RF Fields	EN55022/IEC61000-4-6, 10Vrms – Level 4, in ISM and amateur radio bands between 0.15Mhz and 80Mhz, 80% AM at 1KHz
Rated Power frequency magnetic fields	EN55024/IEC1000-4-8, Level 4: 30 A/m, 50/60 Hz
Voltage Interruptions, Dips, Sags & Surges	EN55024/IECEN61000-4-11: --100% dip for 20mS, Criteria A --100% dip for 5000mS (250/300 cycles), Criteria B --60% dip for 100mS, Criteria B --30% dip for 500mS, Criteria A
Harmonic Current Emissions	EN55011/EN61000-3-2, Class A & C (at 100% load)
Flicker Test	EN61000-3-3

Notes: Above parameters will be tested to 20% margin at 10%, 50%, 100% load.

MECHANICAL DRAWING

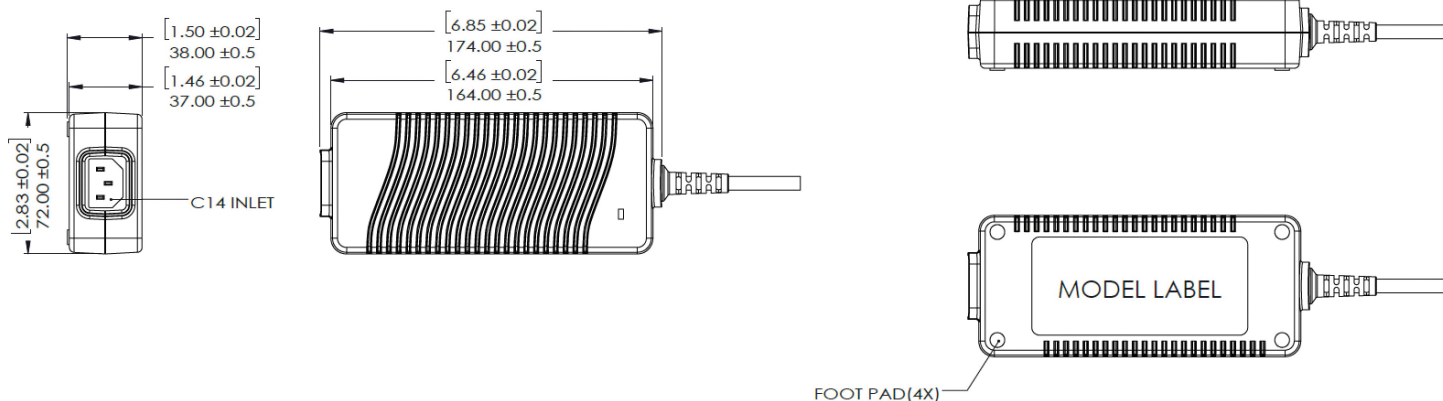



CONNECTOR INFORMATION

Standard 48V models include a 2.5 x 5.5 x 9.5mm straight barrel type connector (Ault #3), center positive. (#51 for the 12V thru 24V models). Other standard options are listed below. The "03" or "51" in the standard model number is replaced by the applicable digits below:

Connector No.	Description	Connector No.	Description
02	2.1 x 5.5 x 9.5 mm straight barrel plug - Center positive	44	2.1 x 5.5 x 9.5 mm straight barrel plug, locking - Center positive
03	2.5 x 5.5 x 9.5 mm straight barrel plug - Center positive (Standard models)	45	2.5 x 5.5 x 9.5 mm straight barrel plug, locking - Center positive
12	5 pin DIN - 180 male connector (Pins 3, 5 = (+); pins 1, 2, 4 = (-))	48	3 pin Snap n Lock, Kycon Kpp - 3P or equivalent (Pin 1 = (+); pin 2 = (-))
22	6 pin DIN male connector (Pins 1, 2 = (+); pins 4, 5 = (-))	49	4 pin Snap n Lock, Kycon Kpp - 4P or equivalent (Pins 1, 3 = (+); pins 2, 4 = (-))
23	8 pin DIN male connector (Pins 3, 7 = (+); pins 1, 4, 6, 8 = (-); shell = FG)	51	6 pin Minitit - Molex 39-01-2060 or equivalent (Pins 1, 4 = (+); pins 3, 6 = (-))
32	9 pin "D" type, female (Pins 8 = (+); pins 5 = (-); all others = NC)	65	Stripped and Tinned Leads
33	2.5 x 5.5 x 12.5 mm straight barrel plug - Center positive	70	2.1 x 5.5 x 11mm right angle barrel plug (high retention) - Center positive
40	2.1 x 5.5 x 9.5 mm right angle barrel plug (High retention) - Center positive	71	2.5 x 5.5 x 11mm right angle barrel plug (high retention) - Center positive
41	2.5 x 5.5 x 9.5 mm right angle barrel plug (High retention) - Center positive	72	2.1 x 5.5 x 9.5 mm straight barrel plug (High retention, no spark) - Center positive
42	2.1 x 5.5 x 11 mm straight barrel plug (High retention) - Center positive	73	2.5 x 5.5 x 9.5 mm straight barrel plug (High retention, no spark) - Center positive
43	2.5 x 5.5 x 11 mm straight barrel plug (High retention) - Center positive	74	EIAJ#5 style connector - Central positive

Notes:  XLR type connectors also are available, consult factory for details.



EFFICIENCY LEVEL VI INFORMATION

Single-Voltage Extrenal AC-DC Power Supply, Basic-Voltage		
Nameplate Output Power (P_{out})	Minimum Average Efficiency in Active Mode (expressed as a decimal)	Maximum Power in No-Load Mode [W]
$P_{out} \leq 1 \text{ W}$	$\geq 0.5 \times P_{out} + 0.16$	≤ 0.100
$1 \text{ W} < P_{out} \leq 49 \text{ W}$	$\geq 0.071 \times \ln(P_{out}) - 0.0014$ $\times P_{out} + 0.67$	≤ 0.100
$49 \text{ W} < P_{out} \leq 250 \text{ W}$	≥ 0.880	≤ 0.210
$P_{out} > 250 \text{ W}$	≥ 0.875	≤ 0.500
Single-Voltage Extrenal AC-DC Power Supply, Low-Voltage		
Nameplate Output Power (P_{out})	Minimum Average Efficiency in Active Mode (expressed as a decimal)	Maximum Power in No-Load Mode [W]
$P_{out} \leq 1 \text{ W}$	$\geq 0.517 \times P_{out} + 0.087$	≤ 0.100
$1 \text{ W} < P_{out} \leq 49 \text{ W}$	$\geq 0.0834 \times \ln(P_{out}) - 0.0014$ $\times P_{out} + 0.609$	≤ 0.100
$49 \text{ W} < P_{out} \leq 250 \text{ W}$	≥ 0.870	≤ 0.210
$P_{out} > 250 \text{ W}$	≥ 0.875	≤ 0.500

In addition, TE150 Series will meet the EU Code of Conduct, Version 5, Tier 2 requirements. (<0.150W no load input power)

X-ON Electronics

Largest Supplier of Electrical and Electronic Components

Click to view similar products for [Desktop AC Adapters](#) category:

Click to view products by [SL Power](#) manufacturer:

Other Similar products are found below :

[212A2136](#) [ADP485-01](#) [SWA-1202](#) [SWA-1501](#) [212A2220](#) [KR8-PS01](#) [1894875](#) [FWE050024B-10A](#) [820A4080G](#) [825A0057-03](#) [SWA-1704W](#) [AD5012N2LM-\(401\)](#) [TRH21A120-49E03-Level-VI](#) [FWC100024A-11A](#) [FWE050012B-10A](#) [AC-DC ADAPTER 90W w/ Cable](#) [FWA065024A-11A](#) [PSA120U-560L6](#) [96PSA-A63W18V1-M](#) [1895235](#) [PW-C0725-W2-B](#) [57-U1](#) [57-U2](#) [CENB1040A1245F02](#) [SED80N2-16.0](#) [SED80N3-16.0](#) [RFQ43442-01](#) [YS50-1903150](#) [MEA-045AA2C K-A](#) [PCM50UT04](#) [PCM50UT05](#) [Adapter 24V230W FSP230-AAAN3](#) [WIRE FSP](#) [TRH100A240-11E12 VI](#) [TR70MB360-01E03 VI](#) [TRH50A240-11E01 VI](#) [TRE36A120-01G03 VI](#) [TRH100A180-11E12 VI](#) [CPSUNOTAKY-07056](#) [CPSUNOTAKY-07168](#) [CPSUNOTAKY-07169](#) [CPSUNOTAKY-07234](#) [CPSUNOTAKY-07236](#) [CPSUNOTAKY-07288](#) [CPSUNOTAKY-07312](#) [CPSUNOTAKY-07342](#) [CPSUNOTAKY-07388](#) [TE30A0503F01](#) [TE30A4803F01](#) [TE40A2403F01](#) [TE40A2403N01](#)