



Industrial



## FEATURES AND BENEFITS

3000W Fan-Cooled (Load & Temp. Controlled)	Remote Setting Multi PSU via RS232,RS485 & I <sup>2</sup> C
Programmable Output Voltage (0% ~ 105%)	Power OK Signal
Programmable Output Current (0% ~ 105%)	Remote ON/OFF, Remote Sense Function
Forced Current Sharing at Parallel Operation	Protection: OVP, OLP, OTP, Fan Failure
Constant Current Limit	3 Year Warranty
Selectable +5V/0.5A or +9V/0.3A Aux Output	Global Control via RS232



## MODEL SELECTION

Model Number <sup>4</sup>	Output Volts	Rated Current	Current Range	Output Power	Ripple & Noise <sup>1</sup>	Line Regulation	Load Regulation	Voltage Tolerance <sup>3</sup>	Efficiency
TF3000A150K	150V	20A	0-20A	3000W	1500mV pk-pk	±1%	±1%	±2%	93%
TF3000A200K	200V	15A	0-15A	3000W	2000mV pk-pk	±1%	±1%	±2%	93%
TF3000A250K	250V	12A	0-12A	3000W	2500mV pk-pk	±1%	±1%	±2%	93%
TF3000A300K	300V	10A	0-10A	3000W	3000mV pk-pk	±1%	±1%	±2%	93%
TF3000A400K	400V	7.5A	0-7.5A	3000W	4000mV pk-pk	±1%	±1%	±2%	93%

Notes : 1. De-rating may apply in low input voltage. Check the derating curve for details

2. Ripple & noise are measured at 20MHz of bandwidth by using a 12" twisted pair-wire terminated with a 0.1uF & 47uF parallel capacitor.

4. Tolerance: includes setup time tolerance, line regulation and load regulation.

5. Other output voltages available, consult factory.

6. All specifications are typical at 230Vac, full load, at 25°C ambient unless noted.

## INPUT

Input Voltage and Frequency <sup>1</sup>	100-240Vac, ±10%, 47-63Hz, 1Ø127-370Vdc
Input Current	115Vac: 19.7A (2000W output) 230Vac: 14.5A (3000W output)
Inrush Current	33A/115VAC, 65A/230VAC
Efficiency	See Model Selection Table
Power Factor	0.95/230VAC, 0.98/115VAC at full load
Leakage Current	< 3.5mA/240VAC

Notes : 1. De-rating may apply in low input voltage. Please check the de-rating curve for more details

## OUTPUT

Output Voltage	See Model Selection Table on pg 1
Output Power <sup>1</sup>	3000W continuous – See model selection table for specific voltage model ratings
Voltage Range	±5.0% Typical adjustment by potentiometer (VR1)
Voltage Tolerance	See Model Selection Table on pg 1
Hold-Up Time	14ms/230VAC at full load
Turn On Time	1100ms
Rise Time	300ms at full load
Ripple and Noise	See Model Selection Table on pg 1
Line/Load Regulation	See Model Selection Table on pg 1

Notes : 1. De-rating may apply in low input voltage. Please check the de-rating curve for more details

## CONNECTOR INFORMATION

	Input Connector	Output Connector	Signal Connector
Pinout:	Term. 1) AC LINE Term. 2) NEUTRAL Term. 3) GROUND	+ and -	See Signal Connector Table on pg 3
Mating Connector /terminal:	#10 wire lugs	1/4-20 Wire Lugs	Connector: JST PHDR-24VS or equivalent Pins: JST SPHD-002T-P0.5 or equivalent



### EMI/EMC COMPLIANCE

Conducted Emissions	Certified EN 55022; EN 61204-3; EN 61000-6-3
Radiated Emissions	Certified EN 55022; EN 61204-3; EN 61000-6-3
Electro-Static Discharge (ESD) Immunity on Power ports	EN55024/IEC61000-4-2
Radiated RF EM Fields Susceptibility	EN55022/EN61000-4-3
Electrical Fast Transients (EFT) /Bursts	EN55024/IEC61000-4-4
Surges, Line to Line (Diff Mode) and Line to GND (CMN Mode)	EN55024/IEC61000-4-5
Conducted Disturbances induced by RF Fields	EN55022/IEC61000-4-6
Rated Power frequency magnetic fields	EN55024/IEC1000-4-8
Voltage Interruptions, Dips, Sags & Surges	EN55024/IECEN61000-4-11
Harmonic Current Emissions	EN61000-3-2
Flicker Test	EN61000-3-3

Notes : 1. The power supply is considered a component which will be installed into a final equipment. The final equipment must be re-confirmed that it still meets EMC directives.

### SAFETY

Safety Certifications	UL62368-1, EN62368-1
-----------------------	----------------------

### RELIABILITY

MTBF	>112,000 hours per MIL-HDBK-217F
------	----------------------------------

### ENVIRONMENT

Operating Temperature	-25 ~ +60°C (Refer to load de-rating curve)
Temperature Derating	See Derating Curve
Vibration	10 ~ 500Hz, 2G 10min./1 cycle, period for 60min. each along X, Y, Z axes Compliance to IEC 68-2-6, IEC 68-2-64
Dimensions	170 x 64 x 280mm 6.69 x 2.5 x 11.02 inch
Cooling	Load and temperature control fan
Relative Humidity	20% to 90%, non-condensing
Storage Temperature and Humidity	-40 ~ +85°C, 10 ~ 95% RH
Weight & Packing	2.6kg 6pcs/carton, 16.6kg/1.86CUFT

### AUXILIARY SIGNALS

Auxiliary Power	Selectable +5V/0.5A or +9V/0.3A auxiliary output
Remote ON / OFF Control	By external switch
Power OK Signal	Open drain signal low when PSU turns on, Max. sink current: 20mA, Max. drain voltage: 40V
Output Voltage Trim	Adjustment of output voltage is between 0 ~ 105% of rated output
Output Current Trim	Adjustment of output current is between 0 ~ 105% of rated output
Parallel (Current Sharing) <sup>1</sup>	Please refer to Current Sharing with Remote Sensing (Parallel Connection) Diagram

Notes : 1. In parallel connection only one unit will operate if the total output load is less than 5% of the rated power.

### PROTECTION

Overvoltage Protection	Variable OVP Refer to VCI VS OVP curve.(OVP Tolerance 7%), Latch Type (Recovery after reset AC power ON or inhibit).
Short Circuit Protection	Constant current, auto-recovery
Overtemperature Protection	85±5°C measured on NTC. Auto recovery
Overload Protection	105% of rated power, constant current type

### ISOLATION SPECIFICATIONS

Isolation <sup>1</sup>	Input-Output: 3000Vac Input-Ground: 1500Vac Output-Ground: 500Vac
Isolation Resistance	I/P-O/P, I/P-FG, O/P-FG: 100M Ohms/500VDC

Notes : 1. This test is done without enclosure: I/P-O/P 4242VDC. If with enclosure: I/P-O/P 2121VDC, I/P-FG:2121VDC, O/P-FG: 707VDC



## MECHANICAL DRAWING

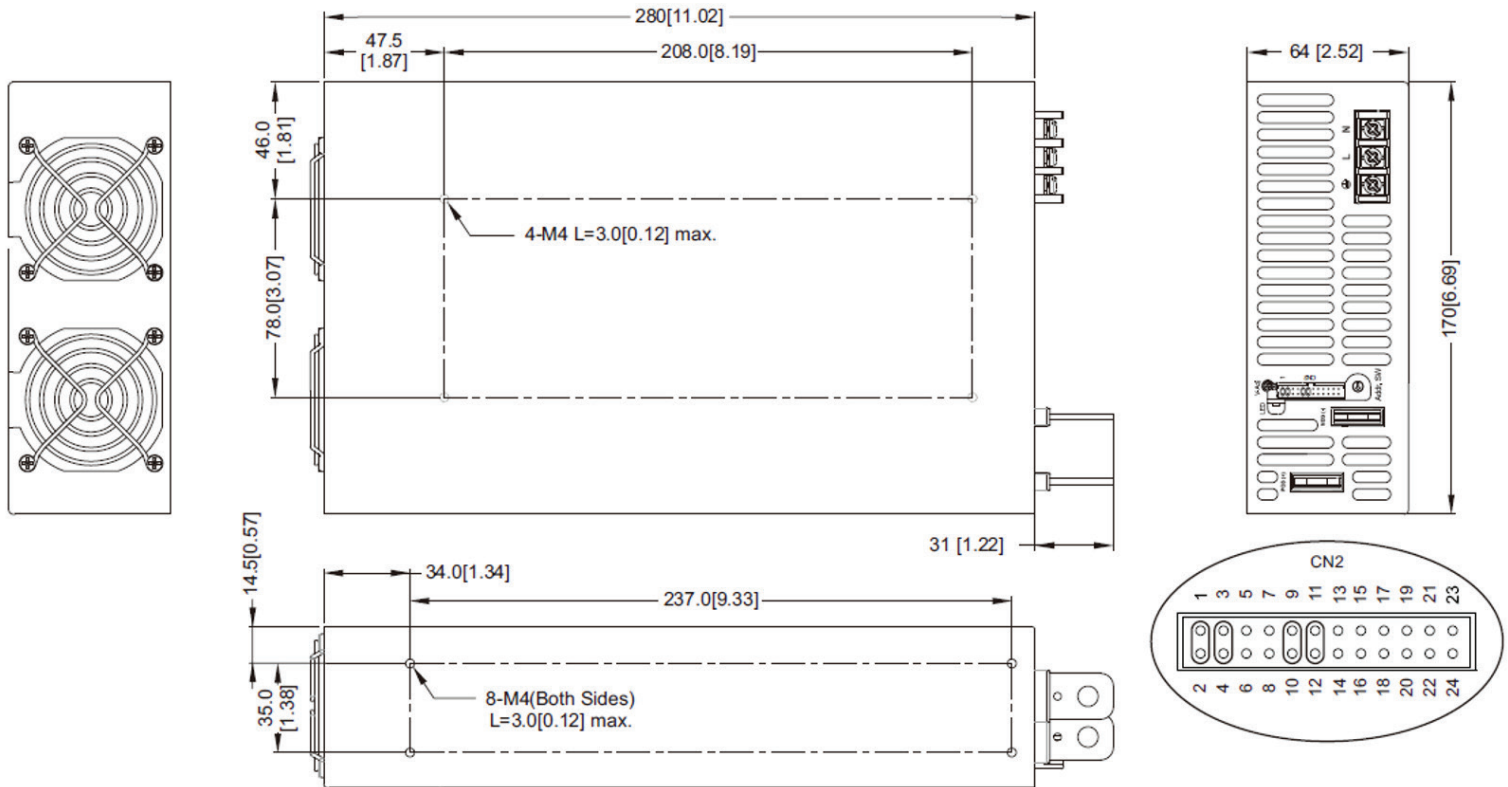









Recommended screw length is measured from the power supply surface.

## SIGNAL CONNECTOR

Pin No.	Function	Description	Pin No.	Function	Description
1	NC		13	ACI	I Program
2	NC		14	GND	Ground
3	NC		15	VCI	V Program
4	NC		16	GND	Ground
5	POK	Power OK	17	AUX	+5V/0.5A or +9V/0.3A Auxiliary power
6	GND	Ground	18	GND	Ground
7	PAR	Parallel operation current share	19	SCL	Serial Clock used in the I <sup>2</sup> C Interface
8	VSET	Aux output setting	20	SDA	Serial Data used in the I <sup>2</sup> C Interface
9	EN-	Inhibit ON/OFF (-)	21	AUX	+5V/0.5A or +9V/0.3A Auxiliary power
10	GND	Ground	22	GND	Ground
11	EN+	Inhibit ON/OFF (+)	23	RX	For RS232 Receiver function
12	AUX	+5V/0.5A or +9V/0.3A Auxiliary power	24	TX	For RS232 Transmission function



## LED STATUS INDICATOR

LED	LED Signal	Status
Solid (Green)		Power OK (Local mode)
Solid (Orange)		Power OK (Remote mode)
Slow Blink (Green)		Power Standby
Fast Blink (Red)		Over Voltage Protection (OVP)
Solid (Red)		Over Load Protection (OLP)
Slow Blink (Red)		Over Temperature Protection (OTP)
Intermittent Blink (Red)		Fan Failure
Interlace Blink (Red)		Power Failure

## REMOTE ON/OFF

(A) Default Setting

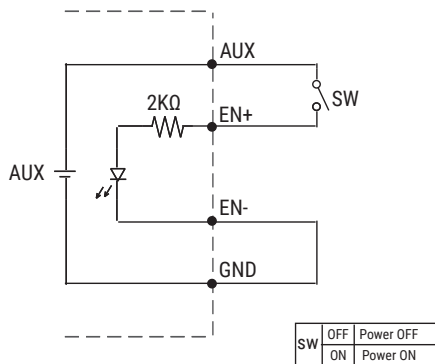

(A) Using internal 5V auxiliary source

(B)

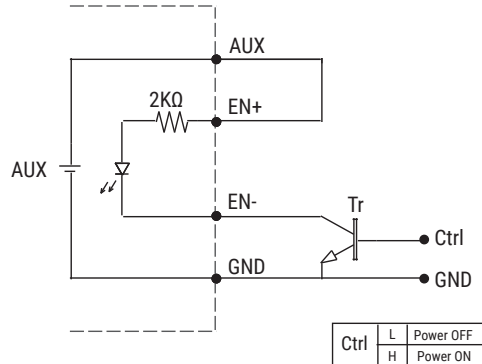

(B) ON / OFF Control by NPN transistor

(C)

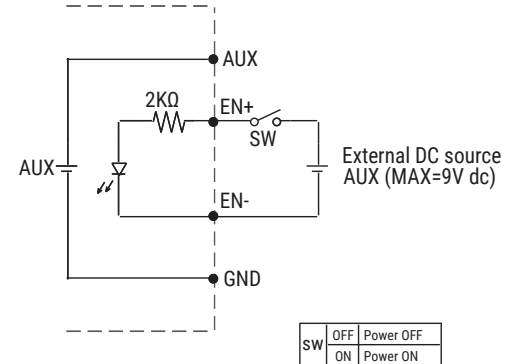

(C) Using external voltage source

\*GND shown in above diagram is referring to the GND of CN2, not the Grounding from main power(NEG-).\*

## DERATING CURVE

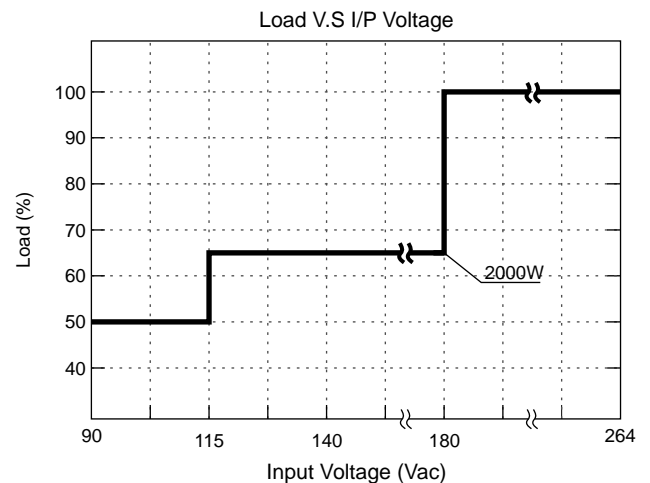
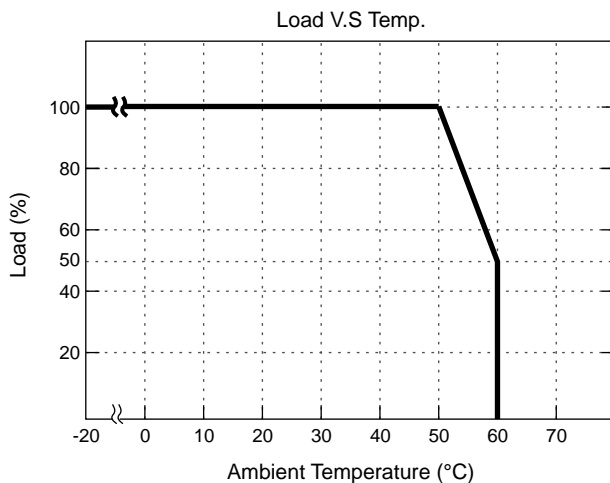



## CMD vs Output Curve

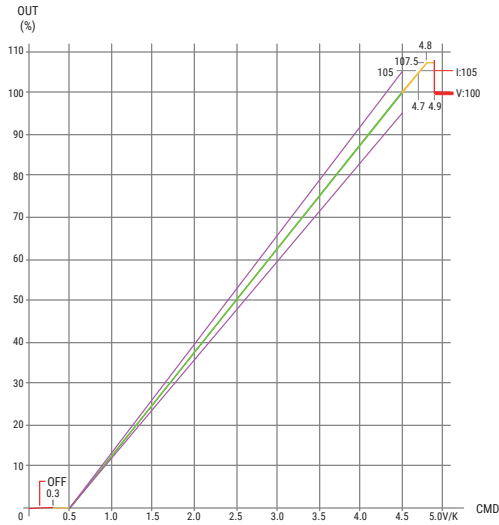

To ensure the power supply output voltage and current could be accurately adjusted, please make sure to adjust the output voltage and current > 10% vs. the rated voltage and current. (e.g. for a 300V unit, please adjust the DC output voltage above 30V to ensure accuracy; same applies to the output current)

## VCI vs OVP Curve

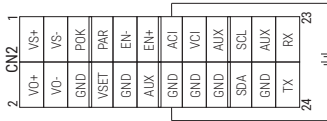
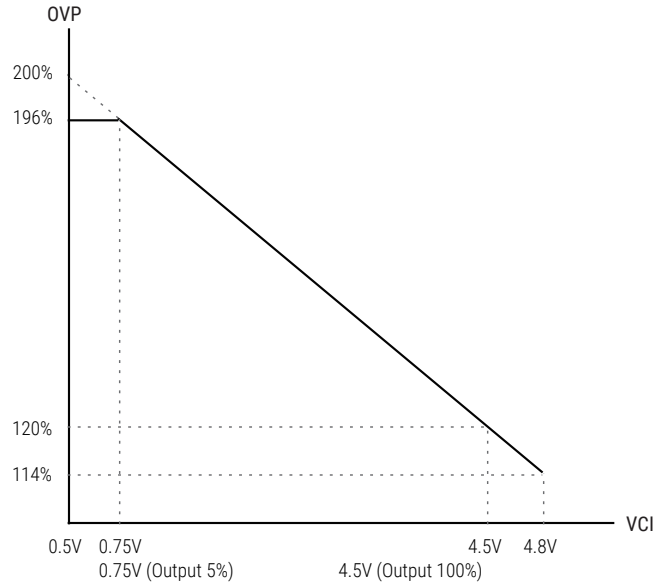

External Voltage (VDC)

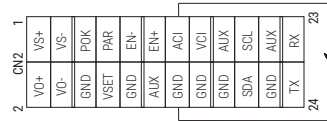

External Resistor (KΩ)

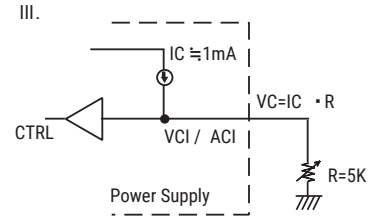
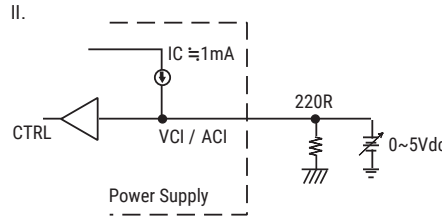
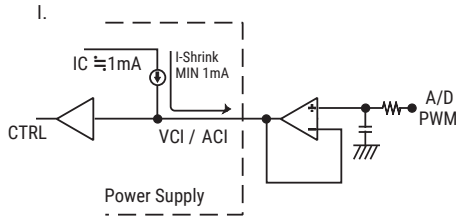

## Power OK Signal & Auxiliary Power Setting

\*The grounding of "AUX" power and P.OK signal should be connected to "GND" port. If "VO-" is connected as Grounding, make sure to short the GND and VO- ports.

Open drain signal low when PSU turns on. Max.  
P.OK sink current: 20mA, Max, drain voltage: 40V.

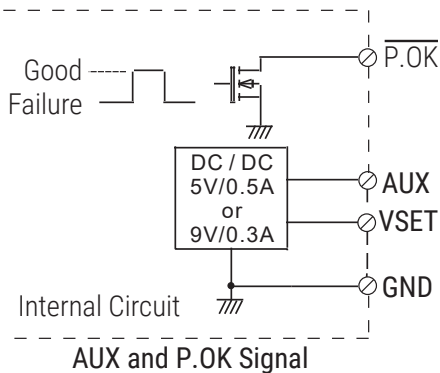

VSET	Open(Default Setting)	5V
	Short To GND	9V

\*Place an additional capacitor to have a better performance of auxiliary power operation.

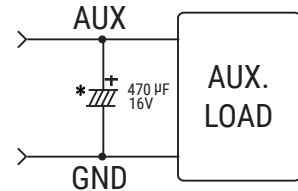

Do NOT exceed 5V/0.5A or 9V/0.3A



## CURRENT SHARING

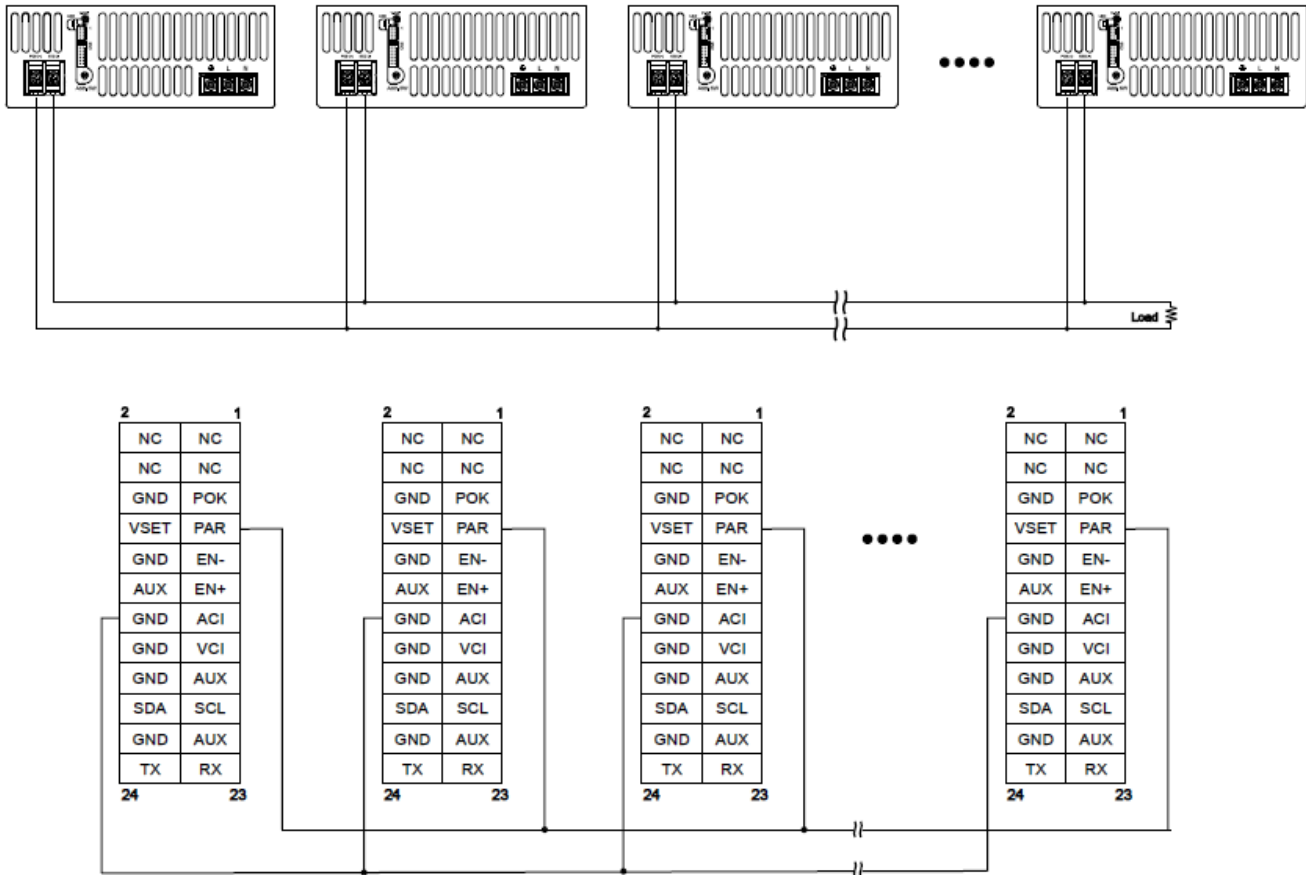

Please connect PAR pins together for current sharing function  
For Series connection, make sure to isolate CN2 control signals



## MOUNTING INSTRUCTIONS

Recommended standard mounting configurations

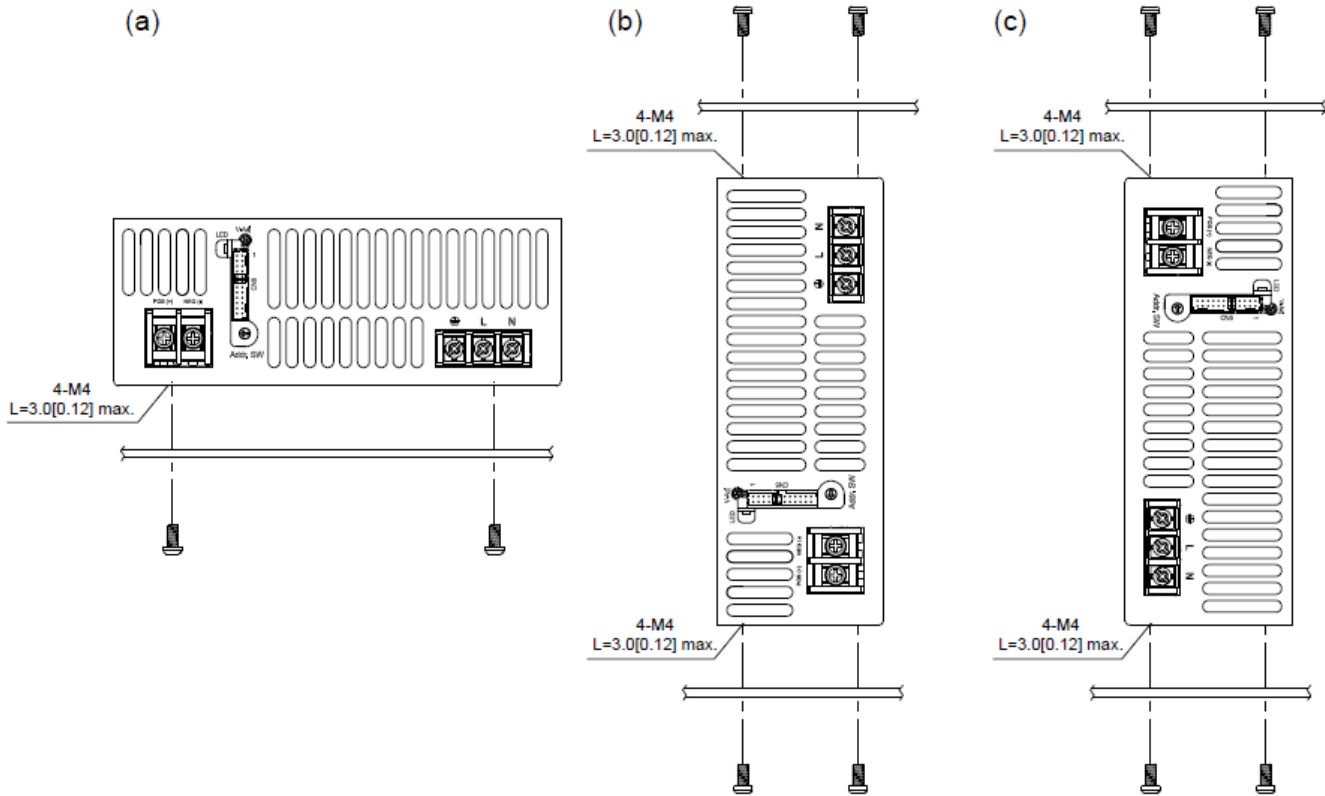

- Notes:**
1. Recommended screw length is measured from the power supply surface.
  2. Ventilating holes on the front and back side panels should not be obstructed. Allow min. 50mm space for air flow. See below.
  3. Recommended torque of M4 mounting screws is  $1.27\text{N} \cdot \text{m}$  (13.0kgf  $\cdot$  cm)

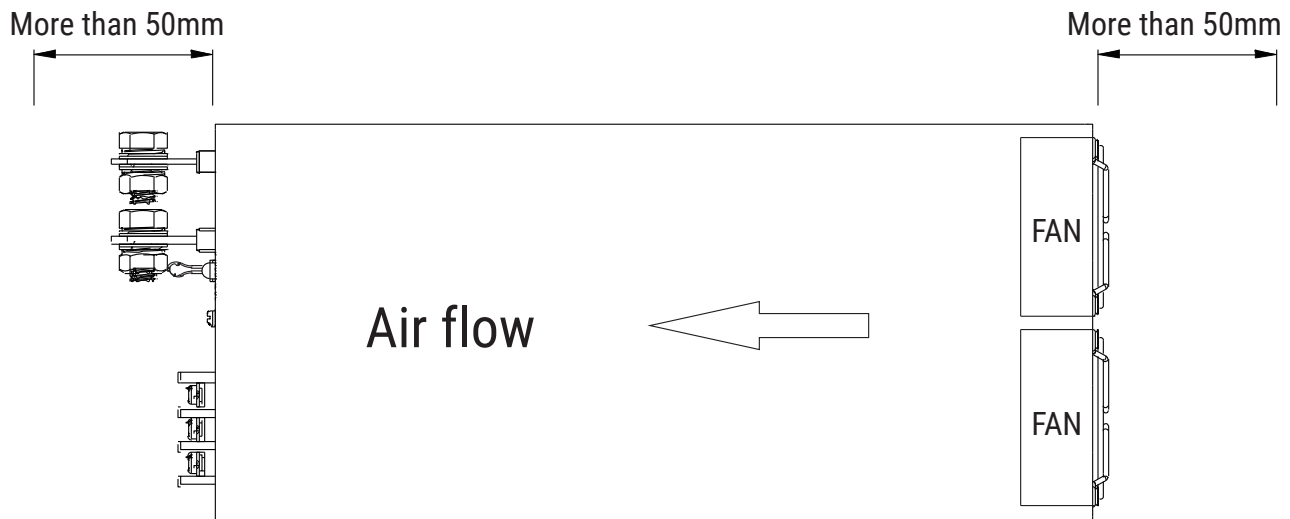



## X-ON Electronics

Largest Supplier of Electrical and Electronic Components

*Click to view similar products for [Switching Power Supplies](#) category:*

*Click to view products by [SL Power](#) manufacturer:*

Other Similar products are found below :

[70841011](#) [73-551-0005](#) [73-551-0048](#) [PS3E-B12F](#) [PS3E-E12F](#) [AAD600S-4-OP](#) [R22095](#) [KD0204](#) [9021](#) [LDIN100150](#) [LPM000-BBAR-01](#)  
[LPX17S-C](#) [EVS57-10R6/R](#) [FP80](#) [FRV7000G](#) [22929](#) [PS3E-F12F](#) [CQM1IA121](#) [40370121900](#) [VI-PU22-EXX](#) [40370121910](#) [LDIN5075](#)  
[LPM615-CHAS](#) [LPX140-C](#) [09-160CFG](#) [70841025](#) [VPX3000-CBL-DC](#) [LPM000-BBAR-05](#) [LPM000-BBAR-08](#) [LPM124-OUTA1-48](#)  
[LPM000-BBAR-07](#) [LPM109-OUTA1-10](#) [LPM616-CHAS](#) [08-30466-1055G](#) [08-30466-2175G](#) [08-30466-2125G](#) [DMB-EWG](#) [TVQF-1219-](#)  
[18S](#) [6504-226-2101](#) [CQM1IPS01](#) [SP-300-5](#) [CQM1-IPS02](#) [VI-MUL-ES](#) [22829](#) [08-30466-0065G](#) [VI-RU031-EWWX](#) [08-30466-0028G](#) [VI-](#)  
[LUL-EU](#) [EP3000AC48INZ](#) [VP-C2104853](#)