

SOLAHD GLQ110 Series Installation & Operating Instructions

Installation & Safety

To comply with the published safety standards, the following must be observed when using this power supply:

1. Maximum ambient temperature for the power supply must not exceed 50°C.
2. When installing the power supply in the end-use equipment, special attention is required to ensure safety compliance with the following safety standards: UL60950, EN60950-1, IEC60950-1, and CSA22.2 No. 234-M90; including the requirements for creepage distances, clearances, and distance through insulation between primary wiring and earth or secondary (SELV) wiring.
3. The power supply's rated input voltage is automatically selected. Please refer to the specification sheet for the input voltage range.
4. The maximum output power of the supply must not exceed the rating indicated in the specification sheet.
5. The earth ground wire must be connected only to the point marked with the earth ground symbol (on the unit).
6. Hazardous voltages exist in the primary circuits. Disconnect the power supply before servicing.
7. When operating with a dc input voltage range, the unit input must be protected by a dc rated fuse in the end-use installation system.
8. The internal fuse should only be replaced with a 4 A, 250 V ac, Type SP0001.1010 manufactured by Schurter AG, Type 216004 manufactured by Littelfuse or Type S501 manufactured by Cooper.
9. This power supply is  marked following the provisions of the Low Voltage Directive, 2006/95/EC.

For technical assistance, contact SolaHD Technical Support at (800) 377-4384 or send an e-mail to tech@solahd.com. Please visit our Web site at www.solahd.com for additional product information and specification sheets.

Output Ratings

Model	Output Voltage (V)	Convection Cooling		30 CFM Forced Air Cooling	
		Max. Output Current (A)	Max. Output Power (W)	Max. Output Current (A)	Max. Output Power (W)
GLQ112	+5	9.0	80	11.0	110
	+12	4.5		5	
	-12	0.7		1.0	
	±5 to ±25	2.5		3.0	
GLQ113	+5	9.0		11.0	
	+15	4.5		5.0	
	-15	0.7		1.0	
	±5 to ±25	2.5		3.0	
GLQ114	+5	9.0		11.0	
	+12	4.5		5.0	
	-12	0.7		1.0	
	+24	3.5		4.5	

Connector PIN Designation

Input Connector	PIN	GLQ112	GLQ113	GLQ114
SK1	1	GND		
	3	Neutral		
	5	Line		
Output Connector	PIN	GLQ112	GLQ113	GLQ114
SK2	1	+5 V		
	2			
	3			
	4	Common		
	5			
	6			
	7			
	8	+12 V	+15 V	+12 V
	9	+12 V	+15 V	+12 V
	10	-12 V	-15 V	-12 V
	11	+5 V to +25 V	+5 V to +25 V	+24 V
	12	-5 V to -25 V	-5 V to -25 V	Common
SK201	1	+Sense		
	2	-Sense		
SK202	1	P OK		
	2	GND		

SOLAHD GLQ110 Series Installation & Operating Instructions

Mechanical Outline

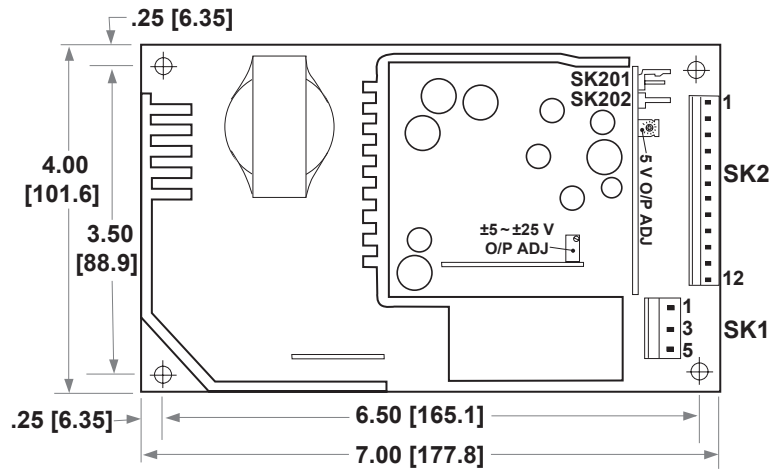

Top View

Mechanical Dimensions

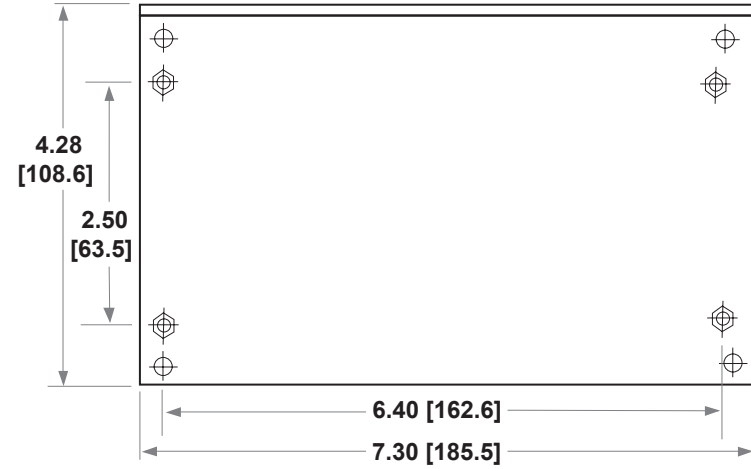

Bottom View with Optional L-Bracket

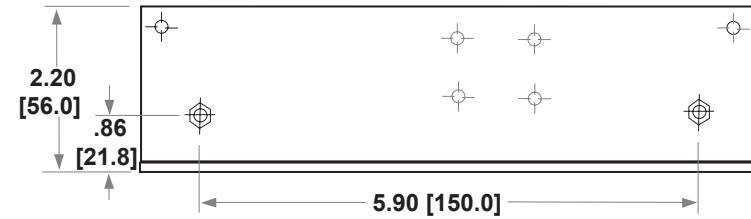

Side View with Optional L-Bracket

All dimensions are in inches [mm]

Screw size: #6-32



leakage current

Output

Maximum power	80 W for convection; 110 W with 30 CFM forced air
Adjustment range	±5% min. on main; 5-25 V on 4th output on GLQ112 and GLQ113
Cross regulation	±2% on output 1; ±3% on outputs 2, 3 & 4
Hold-up time	20 ms @ 80 W load, 115 Vac nominal line
Overload protection	Short circuit protection on all outputs Case overload protected @ 110-145% above peak rating
Overvoltage protection	5.7 to 6.7 Vdc on main output; Latching type, recycle AC to reset
Minimum Load	2 A for the first output, 0.5 A for the 4th output of GLQ114
Logic Control	
Power failure	TTL logic signal goes high 50-150 msec after 5 V output. It goes low at least 4 msec before loss of regulation.
Remote sense	Compensates for 0.5 V lead drop min. Will operate without remote sense connected. Reverse connection protected.

Environmental Specifications

Operating temperature	0° to 50°C ambient. Derate each output 2.5% per degree from 50° to 70°C (except for -C version).
Storage temperature	-40°C to 85°C
Temperature coefficient	±0.04% per °C
Electromagnetic susceptibility	Designed to meet IEC 801, -2, -3, -4, -5, -6, Level 3
Humidity	Operating; non-condensing 5% to 95%
Vibration	Three orthogonal axes, sweep at 1 oct/min., 5 min. dwell at four major resonances 0.75G peak 5Hz to 500Hz, operational
MTBF demonstrated	>550,000 hours at full load and 25°C ambient conditions

Mating Connectors

AC Input	Molex 09-50-8051 (USA) 09-91-0500 (UK); PINS: 08-58-0111
DC Outputs	Molex 09-50-8121 (USA) 09-91-1200 (UK); PINS: 08-58-0111
Remote Sense/ Power Fail	Molex 22-01-1022 (USA) 22-01-1023 (UK); PINS: 08-50-0114

Connector Kit #70-841-008, includes all of the above

1. Specifications subject to change without notice.
2. All dimensions in inches (mm), tolerance is ±0.02" (±0.5mm).
3. Specifications are for convection rating at factory settings unless otherwise stated.
4. Mounting holes M1 and M2 should be grounded for EMI purposes.
5. Mounting hole M1 is safety ground connection.
6. L bracket mounting (6-32) maximum insertion depth is .20".
7. Warranty: 2 year
8. Weight: 1.25 lbs/0.57 kg



Phone: (800) 377-4384
Email: tech@solahd.com
www.solahd.com

SOLAHD GLQ123 Installation & Operating Instructions

To comply with the published safety standards, the following must be observed when using this power supply:

1. Maximum ambient temperature for the power supply must not exceed 50°C.
2. When installing the power supply in the end-use equipment, special attention is required to ensure safety compliance with the following safety standards: UL60950-1, EN60950-1, IEC60950-1, and CSA22.2 No. 60950-1-03; including the requirements for creepage distances, clearances, and distance through insulation between primary wiring and earth or secondary (SELV) wiring.
3. The power supply's rated input voltage is automatically selected. Please refer to the specification sheet for the input voltage range.
4. The maximum output power of the supply must not exceed the rating indicated in the specification sheet.
5. The earth ground wire must be connected only to the point marked with the earth ground symbol (on the unit).
6. The disconnection from the line must be in the end system.
7. Hazardous voltages exist in the primary circuits. Disconnect the power supply before servicing.
8. The unit must be protected by a fuse in the end system. Components, such as capacitors, may be positioned in front of the internal fuse.
9. The internal fuse should only be replaced with a F4AL, 250 V ac, type 19370 manufactured by Wickmann.
10. This equipment is considered Class I according to protection against electric shock.
11. This power supply is **CE** marked following the provisions of the Low Voltage Directive, 2006/95/EC.
12. For technical assistance, contact SolaHD Technical Support at (800) 377-4384 or send an e-mail to tech@solahd.com. Please visit our Web site at www.solahd.com for additional product information and specification sheets.

Output Ratings

Output Voltage (V)	30 CFM Forced Air Cooling (unit not convection rated)	
	Max. Output Current (A)	Max. Output Power (W)
+5	24.0	120
+3.3	25.0	
+12	2.0	
-12	1.0	

Mechanical Outline

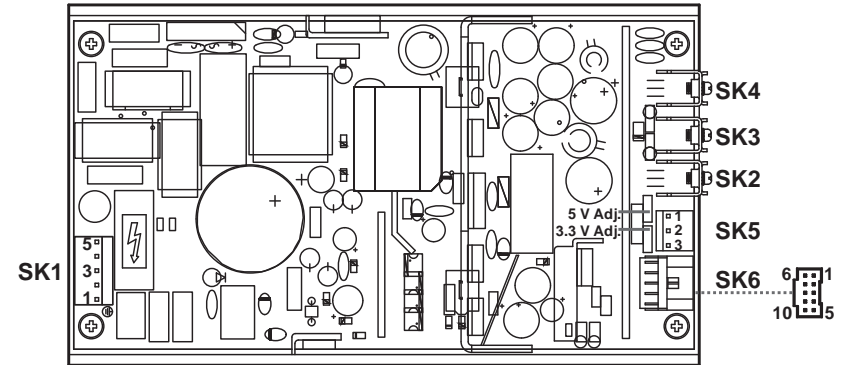

Connector PIN Designation

Input Connector	PIN	Designation
SK1	1	Earth GND
	3	Neutral
	5	Line
Output Connector	PIN	Designation
SK2		+5 V
SK3		Common
SK4		+3.3 V
SK5	1	+12 V
	2	Common
	3	-12 V
SK6	1	+3.3 V SWP (Single Wire Parallel)
	2	-Sense
	3	+3.3 V +Sense
	4	+5 V SWP (Single Wire Parallel)
	5	Common
	6	+5 V +Sense
	7	-Sense
	8	+Inhibit
	9	-Inhibit
	10	Power Fail

SOLAHD GLQ123 Installation & Operating Instructions

Mechanical Dimensions

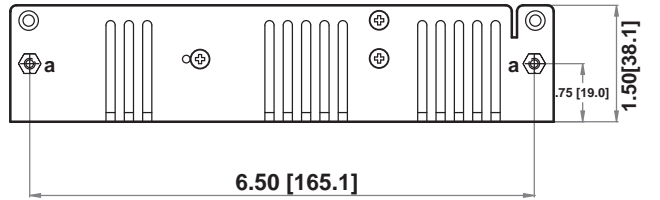

Side View

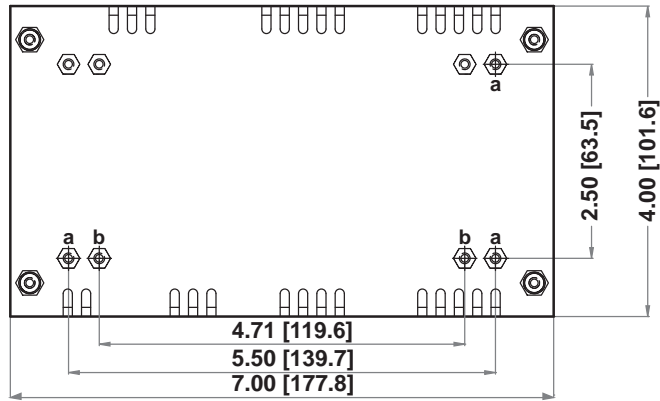

Bottom View

All dimensions are in inches [mm]
 Screw size: a = #6-32 (U.S.); b = M3 (International)
 Maximum screw protrusion: 0.6" [1.5 mm]

Typical Ventilation Setup

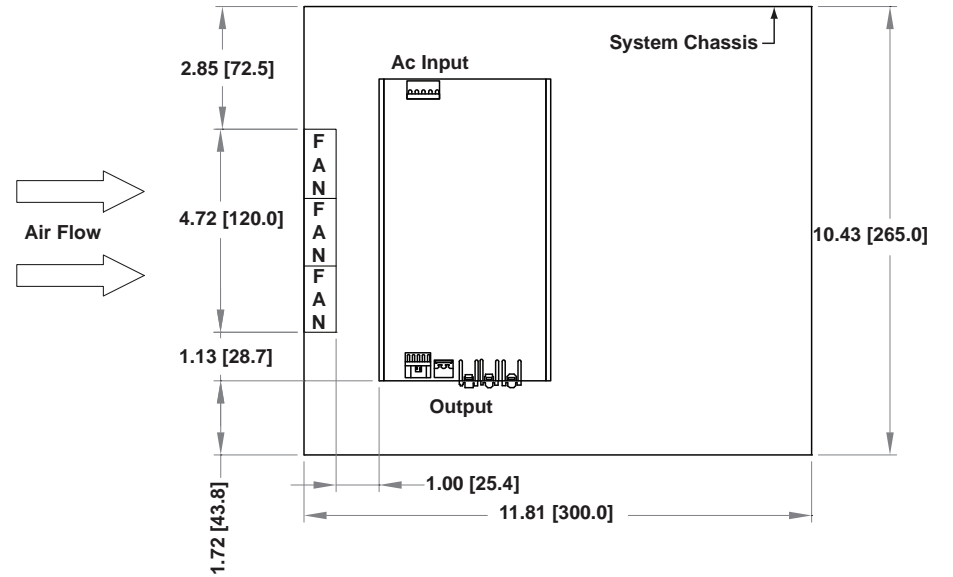

30 CFM forced air cooling
 NOTE: Dimensions and fan used are for reference only

Safety ground leakage current	<1 mA @ 50/60 Hz, 264 Vac input
Output	
Maximum power	70 W for convection; 120 W with 30 CFM forced air
Adjustment range	±5% min. on outputs one and two
Hold-up time	20 ms @ 120 W load, 120 Vac input
Overload protection	Short circuit protection on all outputs Case overload protected @ 110-145% above peak rating
Overvoltage protection	3.3 to 5 V output; 20% to 35% above nominal output
Minimum Load	2 A for the second output
Logic Control	
Power failure	TTL logic signal goes high 100-500 msec after 5 V output. It goes low at least 4 msec before loss of regulation.
Remote inhibit	Requires an external TTL Signal to inhibit outputs
Remote sense	Compensates for 0.5 V lead drop min. Will operate without remote sense connected. Reverse connection protected.

Environmental Specifications

Operating temperature	0° to 50°C ambient. Derate each output 2.5% per degree from 50° to 70°C
Storage temperature	-40°C to 85°C
Temperature coefficient	±0.04% per °C
Electromagnetic susceptibility	Designed to meet EN61000-4, -2, -3, -4, -5, -6, -8, -11, Level 3
Humidity	Operating; non-condensing 5% to 95%
Vibration	Three orthogonal axes, sweep at 1 oct/min., 5 min. dwell at four major resonances 0.7G peak 5Hz to 500Hz, operational
MTBF demonstrated	>1 million hours at full load and 25°C ambient conditions

Mating Connectors

(SK1) AC Input	Molex 09-50-8051 (USA) 09-91-0500 (UK); PINS: 08-58-0111
SK2,3,4	Molex series 19141-0058/0063
(SK5)± 12 V	Molex 09-50-8031 (USA) 09-91-0300 (UK); PINS: 08-58-0111
(SK6) Control Signals	Molex 90142-0010; PINS: 90119-2110 or Amp: 87977-3; PINS: 87309-8

Connector Kit #70-841-012, includes all of the above

1. Specifications subject to change without notice.
2. All dimensions in inches (mm), tolerance is ±0.02" (±0.5mm).
3. Remote inhibit requires an external 5 V @ 10 mA to activate.
4. Mounting maximum insertion depth is 0.12".
5. Warranty: 1 year
6. Weight: 1.38 lbs/0.63 kg



Phone: (800) 377-4384
Email: tech@solahd.com
www.solahd.com

SOLAHD GLQ142 Installation & Operating Instructions

To comply with the published safety standards, the following must be observed when using this power supply:

1. Maximum ambient temperature for the power supply must not exceed 50°C. Derate each output 2.5% per degree from 50°C to 70°C ambient temperature.
2. When installing the power supply in the end-use equipment, special attention is required to ensure safety compliance with the following safety standards: UL60950-1, EN60950-1, IEC60950-1, and CSA22.2 No. 60950-1-03; including the requirements for creepage distances, clearances, and distance through insulation between primary wiring and earth or secondary (SELV) wiring.
3. The ac-dc input connector is approved as a component of the power supply, however, it was not specifically evaluated to IEC60320.
4. This power supply is approved and certified for the rated voltage range of 100 V ac to 250 V ac and/or 120 V dc (minimum) to 370 V dc (maximum).
5. The earth ground wire must be connected only to the point marked with the earth ground symbol (on the unit).
6. The disconnection from the line must be in the end system.
7. When operating with a dc input voltage range, the dc source must be rectified from a mains supply not exceeding 250 V ac. The unit input must also be protected by a dc rated fuse in the end-use installation system.
8. The internal fuse (F1) should only be replaced by a 4 A, 250 V ac, type GDA-V/S501 manufactured by Bussman.
9. This equipment is considered Class I according to protection against electric shock.
10. This power supply is **CE** marked following the provisions of the Low Voltage Directive, 2006/95/EC.
11. For technical assistance, contact SolaHD Technical Support at (800) 377-4384 or send an e-mail to tech@solahd.com. Please visit our Web site at www.solahd.com for additional product information and specification sheets.

Output Ratings

Output Voltage (V)		Convection Cooling		30 CFM Forced Air Cooling	
		Max. Output Current (A)	Max. Output Power (W)	Max. Output Current (A)	Max. Output Power (W)
V1:	+3.3 to +5.7	12.0	80 without cover 60 with cover	25.0	145 with or without cover 145 with cover & internal fan
V2:	+12.0 to +12.7	5.0		6.0	
V3:	-12.0 to -15.0	1.0		1.5	
V4:	+3.3 to +25.0	1.5		4.5	

Mechanical Outline

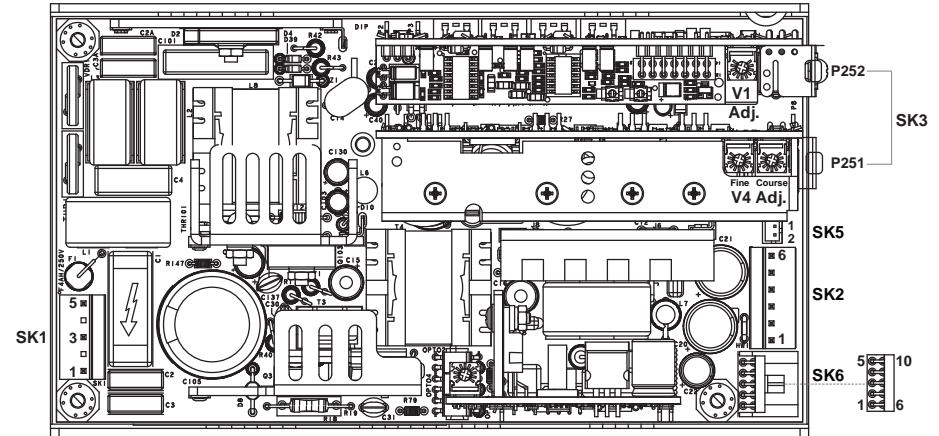

Connector PIN Designation

Input Connector	PIN	Designation
SK1	1	Earth GND
	3	Neutral
	5	Line
Output Connector	PIN	Designation
SK2	1	V2
	2, 4	Common
	3	V3
	5	V4
	6	V4 (Return)
	SK3	P251
	P252	V1
SK5 <small>(optional for units with cover & fan)</small>	1	V2
	2	Common
SK6	1	V4 SWP (Single Wire Parallel)
	2	Dc OK
	3	+V4 Sense
	4	V1 SWP (Single Wire Parallel)
	5	Common
	6	+V1 Sense
	7	Sense Common
	8	+Inhibit
	9	-Inhibit
	10	Power Fail

SOLAHD GLQ142 Installation & Operating Instructions

Mechanical Dimensions

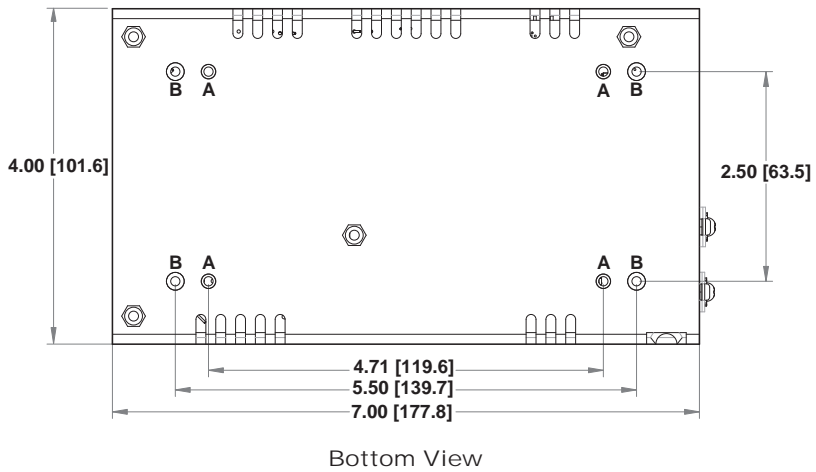
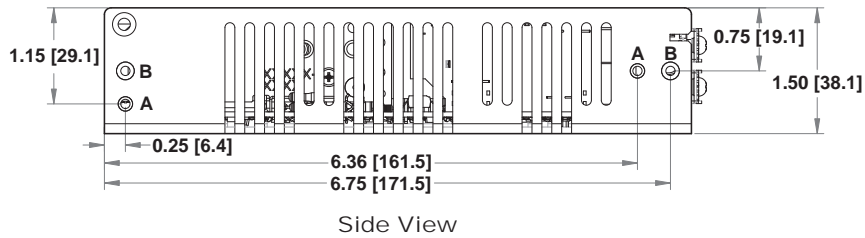

All dimensions are in inches [mm]

Screw sizes: A = M3 (International); B = #6-32 (U.S.)

Recommended maximum screw protrusion: 0.06" [1.5 mm]

Typical Ventilation Setup

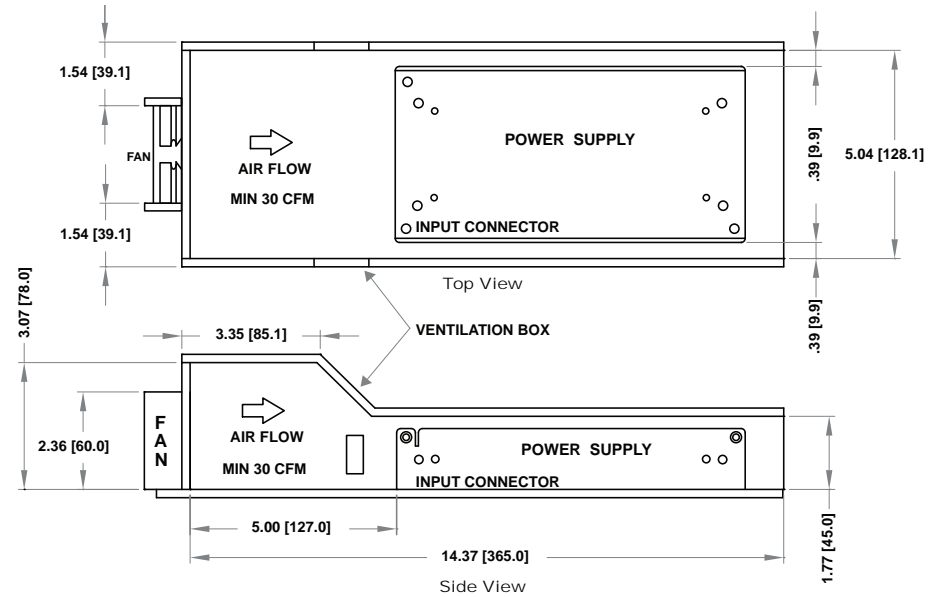

30 CFM forced air cooling

NOTE: Dimensions and fan used are for reference only

leakage current	
Output	
Maximum power	80 W convection (60 W with cover) 145 W with 30 CFM forced air (100 W with cover)
Adjustment range	3.3 - 5.5 V on main; -12 - 15 V on 3rd output; 3.3 - 25 V on 4th output
Hold-up time	20 ms @ 175 W load at nominal line
Overload protection	Short circuit protection on all outputs Case overload protected @ 110-145% above peak rating
Overvoltage protection	Tracks outputs 1, 3 & 4; 10 to 35%
Minimum Load	0.5 A for the 4th output
Logic Control	
AC Power failure	TTL logic signal goes high 100-500 msec after V1 output. It goes low at least 4 msec before loss of regulation.
Remote inhibit	Requires contact closure to inhibit outputs
Remote sense	Compensates for 0.5 V lead drop min. Will operate without remote sense connected. Reverse connection protected.
DC - OK	TTL logic signal goes high after main output is in regulation. It goes low when there is a loss of regulation.

Environmental Specifications

Operating temperature	0° to 50°C ambient. Derate each output 2.5% per degree from 50° to 70°C (except for -C version).
Storage temperature	-40°C to 85°C
Temperature coefficient	±0.4% per °C
Electromagnetic susceptibility	Designed to meet IE61000-4, -2, -3, -4, -5, -6, -8, -11 Level 3
Humidity	Operating; non-condensing 5% to 95%
Vibration	Three orthogonal axes, sweep at 1 oct/min, 5 min. dwell at four major resonances 0.75 G peak 5 Hz to 500 Hz, operational
MTBF demonstrated	>550,000 hours at full load and 25°C ambient conditions

Mating Connectors

(SK1) AC Input	Molex 09-50-8051 (USA) Molex 09-91-0500 (UK); PINS: 08-58-0111
(SK2) Aux DC Output	Molex 09-50-8061 (USA); Molex 09-91-0600 (UK); PINS: 08-58-0111
(SK6) Control Signals	Molex 90142-0010 (USA); PINS: 90119-2110 or Amp: 87977-3, PINS: 87309-8
(SK4) Main Output	Molex BB-19141-0058

Connector Kit #70-841-017, includes all of the above

1. Specifications subject to change without notice.
2. All dimensions in inches (mm), tolerance is ±0.02" (±0.5mm).
3. Specifications are for convection rating at factory settings unless otherwise stated.
4. Mounting screw maximum insertion depth is 0.12".
5. Warranty: 2 years
6. Weight: 1.63 lbs/0.74 kg



Phone: (800) 377-4384
Email: tech@solahd.com
www.solahd.com

SOLAHD GLQ150 Series Installation & Operating Instructions

Installation & Safety

To comply with the published safety standards, the following must be observed when using this power supply:

1. Maximum ambient temperature for the power supply must not exceed 50°C.
2. When installing the power supply in the end-use equipment, special attention is required to ensure safety compliance with the following safety standards: UL60950-1, EN60950-1, IEC60950-1, and CSA22.2 No. 60950-1-03; including the requirements for creepage distances, clearances, and distance through insulation between primary wiring and earth or secondary (SELV) wiring.
3. The power supply's rated input voltage is automatically selected. Refer to the specification sheet for the input voltage range.
4. The maximum output power of the supply must not exceed the rating indicated in the specification sheet.
5. The earth ground wire must be connected only to the point marked with the earth ground symbol (on the unit).
6. Hazardous voltages exist in the primary circuits. Disconnect the power supply before servicing.
7. When operating with a dc input voltage range, the unit input must be protected by a dc rated fuse in the end-use installation system.
8. The internal fuse should only be replaced with a 5 A, 250 V ac, type SP0001.1011 manufactured by Schurter AG, type 216005 manufactured by Littelfuse or type S501 manufactured by Cooper.
9. This power supply is CE marked following the provisions of the Low Voltage Directive, 2006/95/EC.

For technical assistance, contact SolaHD Technical Support at (800) 377-4384 or send an e-mail to tech@solahd.com. Please visit our Web site at www.solahd.com for additional product information and specification sheets.

Output Ratings

Model	Output Voltage (V)	Convection Cooling		30 CFM Forced Air Cooling	
		Max. Output Current (A)	Max. Output Power (W)	Max. Output Current (A)	Max. Output Power (W)
GLQ152	+5	15.0	75 with cover 110 without cover	22.0	130 with cover 150 without cover
	+12	6.0		8.0	
	-12	2.0		2.5	
	+5 to +25	2.5		3.0	
GLQ153	+5	15.0		22.0	
	+15	4.8		6.4	
	-15	1.6		2.0	
GLQ154	+5 to +25	2.5		3.0	
	+5	15.0		22.0	
	+12	6.0		8.0	
	-12	2.0	2.5		
	+24	3.5	4.5		

Mechanical Outline

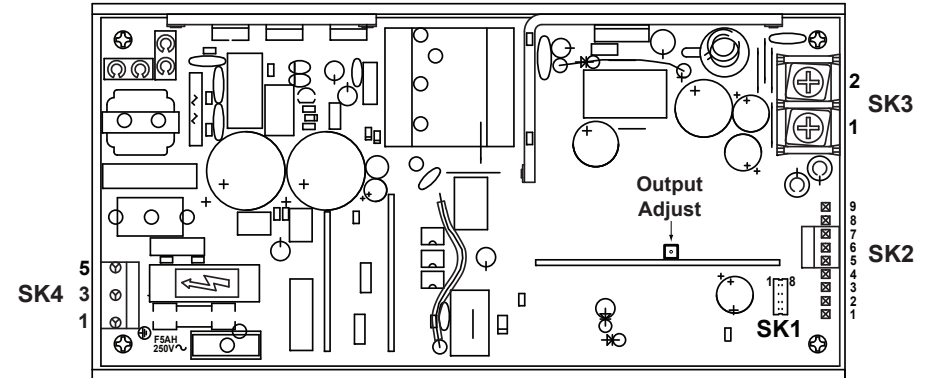

Connector PIN Designation

Output Connector	PIN	GLQ152	GLQ153	GLQ154
SK1	1		Inhibit -ve	
	2		Inhibit +ve	
	3	+12 V	+15 V	+12 V
	4	No connection		
	5	Common		
	6	-Sense		
	7	+Sense		
	8	C-Share		
SK2	1, 2	+12 V	+15 V	+12 V
	3, 4, 5	Common		
	6	-12 V	-15 V	-12 V
	7	P OK		
	8	+5 V to +25 V (float)		+24 V
SK3	9	Common (float)		Common
	T.B. 2	+5 V		
	T.B. 1	Common		
Input Connector	PIN	GLQ152	GLQ153	GLQ154
SK4	1	Earth GND		
	2	PIN removed		
	3	Line		
	4	PIN removed		
	5	Neutral		

SOLAHD GLQ150 Series Installation & Operating Instructions

Mechanical Dimensions

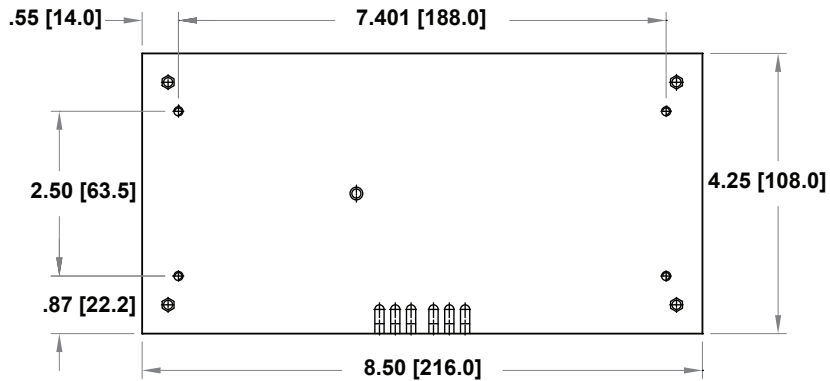

Bottom View

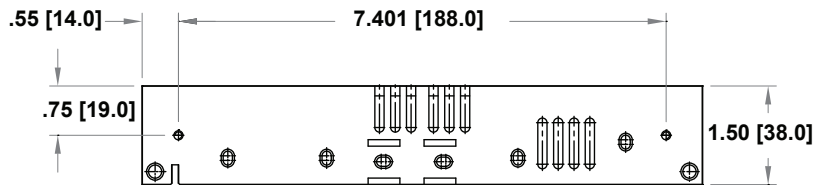

Side View

All dimensions are in inches [mm]
Screw size: #6-32

Typical Ventilation Setup

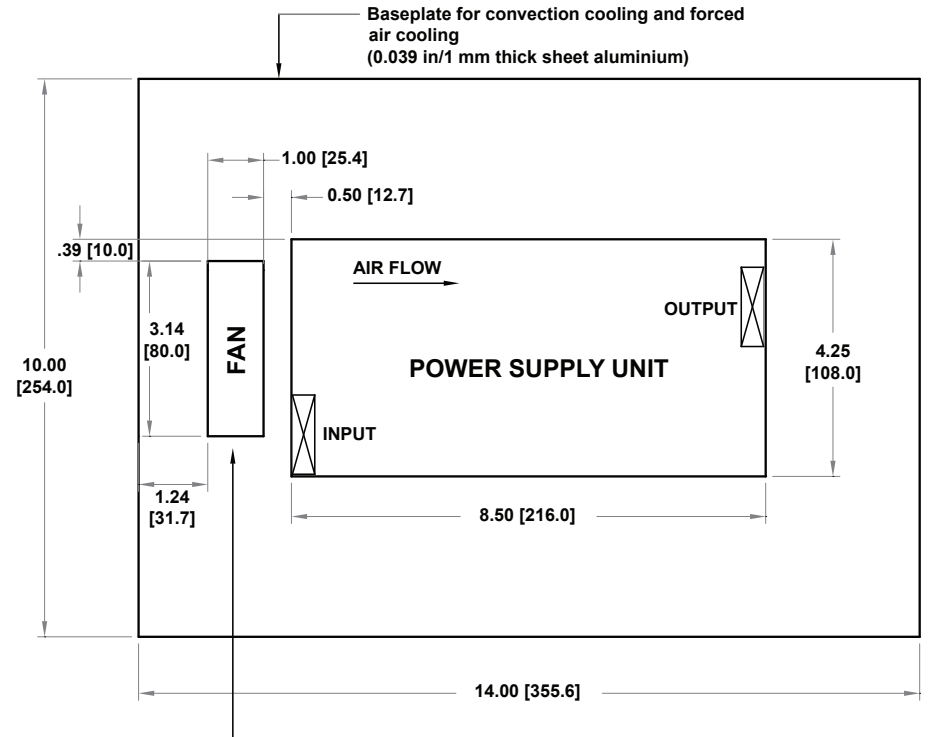

For forced air cooling only

Fan used: MINEBEA 3110NL-04W-B30, 12 V dc, 0.14 A
Dc input for fan during testing: 12 V dc

NOTE: Dimensions and fan used are for reference only



Output	
Maximum power	110 W convection (75 W with cover) 150 W with 30 CFM forced air (130 W with cover)
Adjustment range	±5% on main; 5-25 V on 4th output on GLQ152 & GLQ153
Cross regulation	±2% on output 1; ±3% on outputs 2, 3 & 4
Hold-up time	20 ms @ 110 W load at nominal line
Overload protection	Short circuit protection on all outputs Case overload protected @ 110-145% above peak rating
Overvoltage protection	5.7 to 6.7 Vdc on main output
Minimum Load	2 A for the first output, 0.1 A for second and third outputs, 0.5 A for the 4th output of GLQ154
Logic Control	
Power failure	TTL logic signal goes high 50-150 msec after 5 V output. It goes low at least 3 msec before loss of regulation.
Remote inhibit	Requires an external TTL high signal to inhibit outputs
Remote sense	Compensates for 0.5 V lead drop min. Will operate without remote sense connected. Reverse connection protected.

Environmental Specifications

Operating temperature	0° to 50°C ambient. Derate each output 2.5% per degree from 50° to 70°C
Storage temperature	-40°C to 85°C
Temperature coefficient	±0.04% per °C
Electromagnetic susceptibility	Designed to meet IEC 801, -2, -3, -4, -5, -6, Level 3
Humidity	Operating; non-condensing 5% to 95%
Vibration	Three orthogonal axes, sweep at 1 oct/min, 5 min. dwell at four major resonances 0.75 G peak 5 Hz to 500 Hz, operational
MTBF demonstrated	>550,000 hours at full load and 25°C ambient conditions

Mating Connectors

AC Input (SK4)	Molex 09-50-8051 (USA) Molex 09-91-0500 (UK); PINS: 08-58-0111
Aux DC Output	Molex 09-50-8091 (USA)
Power Fail (SK2)	Molex 09-91-0900 (UK); PINS: 08-58-0111
Remote Sense/	Molex 51110-0851 (USA)
Remote Inhibit (SK1)	PINS: 503-94-8100

Connector Kit #70-841-010, includes all of the above

1. Specifications subject to change without notice.
2. All dimensions in inches (mm), tolerance is ±0.02" (±0.5mm).
3. Specifications are for convection rating at factory settings unless otherwise stated.
4. Remote inhibit requires an external 5 V @ 10 mA to activate.
5. Mounting (6-32) maximum insertion depth is .12".
6. Warranty: 2 years
7. Weight: 1.75 lbs/0.80 kg



Phone: (800) 377-4384
Email: tech@solahd.com
www.solahd.com

SOLAHD GLQ172 Installation & Operating Instructions

To comply with the published safety standards, the following must be observed when using this power supply:

- Maximum ambient temperature for the power supply must not exceed 50°C.
- When installing the power supply in the end-use equipment, special attention is required to ensure safety compliance with the following safety standards: UL60950-1, EN60950-1, IEC60950-1, and CSA22.2 No. 60950-1-03; including the requirements for creepage distances, clearances, and distance through insulation between primary wiring and earth or secondary (SELV) wiring.
- The ac-dc input connector is approved as a component of the power supply, however, it was not specifically evaluated to IEC60320.
- This power supply is approved and certified for the rated voltage range of 100 V ac to 250 V ac and/or 120 V dc (minimum) to 300 V dc (maximum).
- The earth ground wire must be connected only to the point marked with the earth ground symbol (on the unit).
- The disconnection from the line must be in the end system.
- When operating with a dc input voltage range, the dc source must be rectified from a mains supply not exceeding 250 V ac. The unit input must also be protected by a dc rated fuse in the end-use installation system.
- The internal fuse (F1) should only be replaced by a 4 A, 250 V ac, type GDA-V/S501 manufactured by Bussman, type 19194 manufactured by Wickmann, or type 226004 manufactured by Littelfuse.
- This equipment is considered Class I according to protection against electric shock.
- This power supply is **CE** marked following the provisions of the Low Voltage Directive, 2006/95/EC.
- For technical assistance, contact SolaHD Technical Support at (800) 377-4384 or send an e-mail to tech@solahd.com. Please visit our Web site at www.solahd.com for additional product information and specification sheets.

Output Ratings

Output Voltage (V)	Convection Cooling		30 CFM Forced Air Cooling	
	Max. Output Current (A)	Max. Output Power (W)	Max. Output Current (A)	Max. Output Power (W)
V1: +3.3 to +5.7	15.0	110 without cover 175 with or without cover	30.0	
V2: +12.0	6.0		8.0	
V3: -12.0 to -15.0	1.5		3.0	
V4: +3.3 to +25.0	2.0		5.0	
+5 VSB	0.2		0.2	

Mechanical Outline

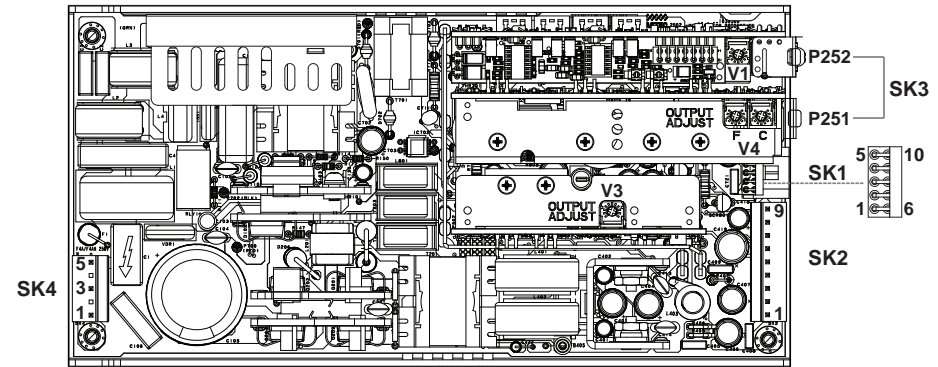

Connector PIN Designation

Output Connector	PIN	Designation
SK1	1	V2 SWP (Single Wire Parallel) (No connection - optional)
	2	+5 VSB
	3	+V2 sense (No connection - optional)
	4	V1 SWP (Single Wire Parallel)
	5	Common
	6	+V1 sense
	7	Sense common
	8	Remote inhibit
	9	Dc power good
	10	Power fail
SK2	1,2	V2
	3, 4, 5	Common
	6	V3
	7	P OK
	8	V4
SK3	P251	V1
	P252	V1
Input Connector	PIN	Designation
SK4	1	Earth GND
	3	Line
	5	Neutral

SOLAHD GLQ172 Installation & Operating Instructions

Mechanical Dimensions

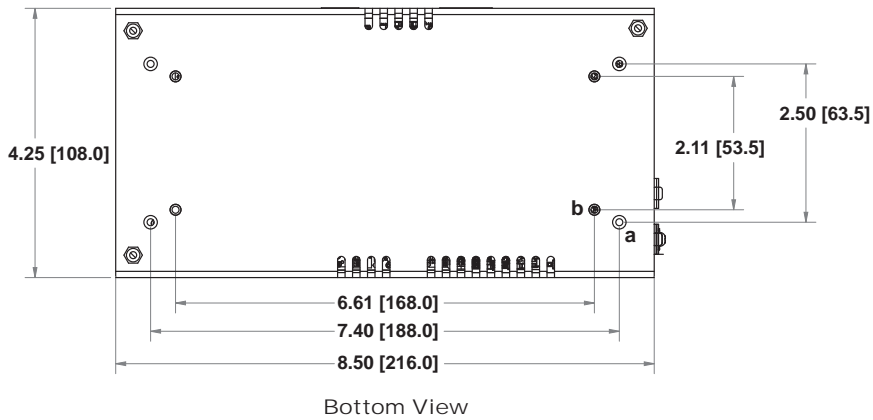
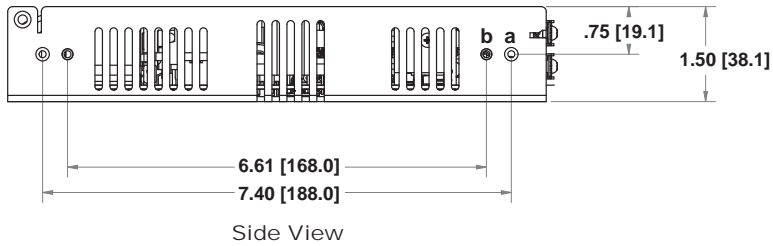

All dimensions are in inches [mm]
 Screw sizes: a = #6-32 (U.S.); b = M3 (International)
 Maximum screw protrusion: 0.6" [1.5 mm]

Typical Ventilation Setup

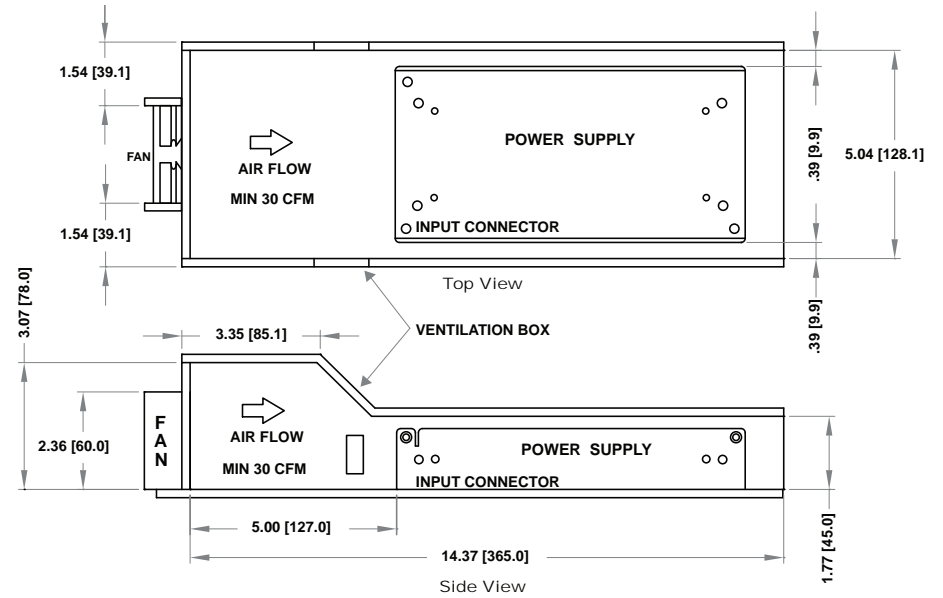

30 CFM forced air cooling
 NOTE: Dimensions and fan used are for reference only

leakage current	1.0 mA @ 50/60 Hz, 264 Vac input
Output	
Maximum power	110 W for convection (75 W with cover); 175 W with 30 CFM forced air (130 W with cover)
Adjustment range	3.3 - 5.5 V on main; -12 - 15 V on 3rd output; 3.3 - 25 V on 4th output
Standby output	5 V @ 200 mA regulated \pm 5%
Hold-up time	20 ms @ 175 W load at nominal line
Overload protection	Short circuit protection on all outputs Case overload protected @ 110-145% above peak rating
Overvoltage protection	Tracks outputs 1, 3 & 4; 15 to 35%
Minimum load	0.5 A on 4th output
Logic Control	
AC Power failure	TTL logic signal goes high 100-500 msec after V1 output. It goes low at least 4 msec before loss of regulation.
Remote inhibit	Requires a contact closure to inhibit outputs
Remote sense	Compensates for 0.5 V lead drop min. Will operate without remote sense connected. Reverse connection protected.
DC - OK	TTL logic signal goes high after main output is in regulation. It goes low when there is a loss of regulation.

Environmental Specifications

Operating temperature	0° to 50°C ambient. Derate each output 2.5% per degree from 50° to 70°C (except for -C version).
Storage temperature	-40°C to 85°C
Temperature coefficient	\pm 0.4% per °C
Electromagnetic susceptibility	Designed to meet EN61000-4; -2, -3, -4, -5, -6, -8, -11 Level 3
Humidity	Operating; non-condensing 5% to 95%
Vibration	Three orthogonal axes, sweep at 1 oct/min., 5 min. dwell at four major resonances 0.75G peak 5Hz to 500Hz, operational
MTBF demonstrated	>550,000 hours at full load and 25°C ambient conditions

Mating Connectors

(SK4) AC Input	Molex 09-50-8051 (USA); Molex 09-91-0500 (UK) PINS: 08-58-0111
(SK3) Main Outputs	Molex 19141-0058/0063
(SK2) Aux DC Output/Power fail	Molex 09-50-8091 (USA); Molex 09-91-0900 (UK); PINS: 08-58-0111 Amp: 87977-3; PINS: 87309-8
(SK1) Control Signals	Molex 90142-0010 (USA); PINS: 90119-2110 or Amp: 87977-3; PINS: 87309-8

Connector Kit #70-841-015, includes all of the above

1. Specifications subject to change without notice.
2. All dimensions in inches (mm), tolerance is \pm 0.02" (\pm 0.5mm).
3. Specifications are for convection rating at factory settings unless otherwise stated.
4. Mounting screw maximum insertion depth is 0.12".
5. Warranty: 2 year
6. Weight: 2 lbs/0.91 kg



Phone: (800) 377-4384
Email: tech@solahd.com
www.solahd.com

To comply with the published safety standards, the following must be observed when using this power supply:

- Maximum ambient temperature for the power supply must not exceed 50°C.
- When installing the power supply in the end-use equipment, special attention is required to ensure safety compliance with the following safety standards: UL60950-1, EN60950-1, IEC60950-1, and CSA22.2 No. 60950-1-03; including the requirements for creepage distances, clearances, and distance through insulation between primary wiring and earth or secondary (SELV) wiring.
- The power supply's rated input voltage is automatically selected. Please refer to the specification sheet for the input voltage range.
- The maximum output power of the supply must not exceed the rating indicated in the specification sheet.
- The earth ground wire must be connected only to the point marked with the earth ground symbol (on the unit).
- The disconnection from the line must be in the end system.
- Hazardous voltages exist in the primary circuits. Disconnect the power supply before servicing.
- The unit must be protected by a fuse in the end system. Components, such as capacitors, may be positioned in front of the internal fuse.
- When operating with a dc input voltage range, the dc source must be rectified from a mains supply not exceeding 250 V ac. The unit input must also be protected by a dc rated fuse in the end-use installation system.
- The internal fuse should only be replaced with a F6.3AH, 250 V ac, type 21606.3 manufactured by Littelfuse, type 50CF063H manufactured by Triad, or type S501 manufactured by Cooper.
- This equipment is considered Class I according to protection against electric shock.
- This power supply is marked following the provisions of the Low Voltage Directive, 2006/95/EC.
- For technical assistance, contact SolaHD Technical Support at (800) 377-4384 or send an e-mail to tech@solahd.com. Please visit our Web site at www.solahd.com for additional product information and specification sheets.

Output Ratings

Model	Output Voltage (V)	30 CFM Forced Air Cooling (unit not convection rated)	
		Max. Output Current (A)	Max. Output Power (W)
GLQ252-C	+5	35.0	250 with cover
	+12	10.0	
	-12	6.0	
	+5 to +25	6.0	
GLQ253-C	+5	35.0	
	+15	10.0	
	-15	6.0	
	+5 to +25	6.0	

Mechanical Outline

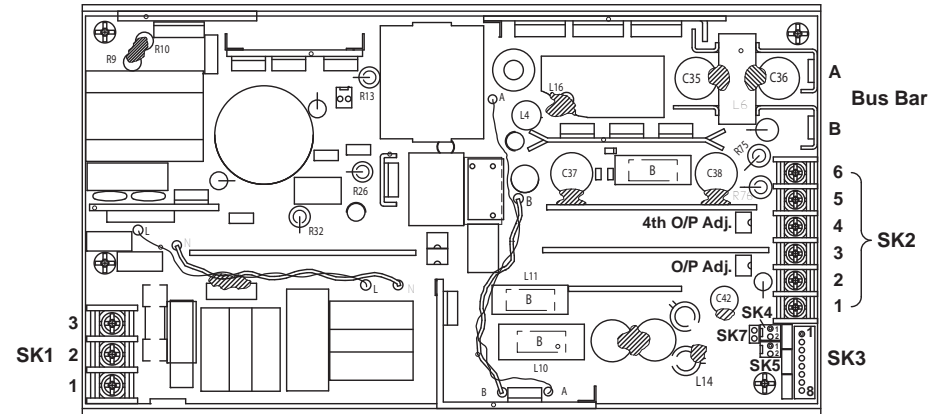

Connector PIN Designation

Input Connector	PIN	GLQ252-C	GLQ253-C
SK1	1	Neutral	
	2	Line	
	3	Earth GND	
Output Connector	PIN	GLQ252-C	GLQ253-C
Bus Bar	A	+5 V	
	B	Common	
SK2	1	+12 V	+15 V
	2, 3	Common	
	4	-12 V	-15 V
	5	Return (float)	
	6	+5 V to +25 V adj. (float)	
	SK3	1	+Sense
SK3	2	-Sense	
SK3	3	Inhibit (normally open)	
SK3	4	Inhibit (normally closed)	
SK3	5	Common	
SK3	6	Active current share	
SK3	7	P OK	
SK3	8	Dc OK	
SK4	1	Fan (+)	
	2	Fan (-)	
SK5	1	+5 V (aux)	
	2	Common	
SK7	1	Fan (+)	
	2	Fan (-)	

Mechanical Dimensions

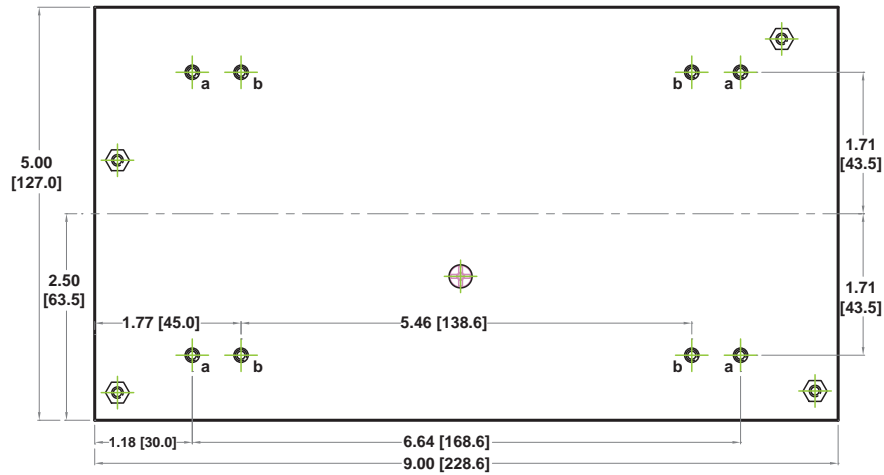
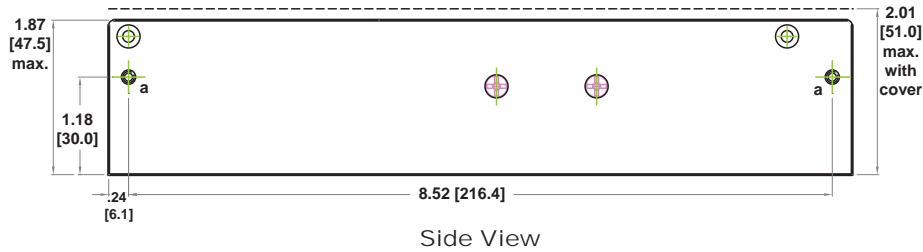

All dimensions are in inches [mm]

Screw sizes: a = #6-32 (U.S.); b = M3 (International)

Typical Ventilation Setup

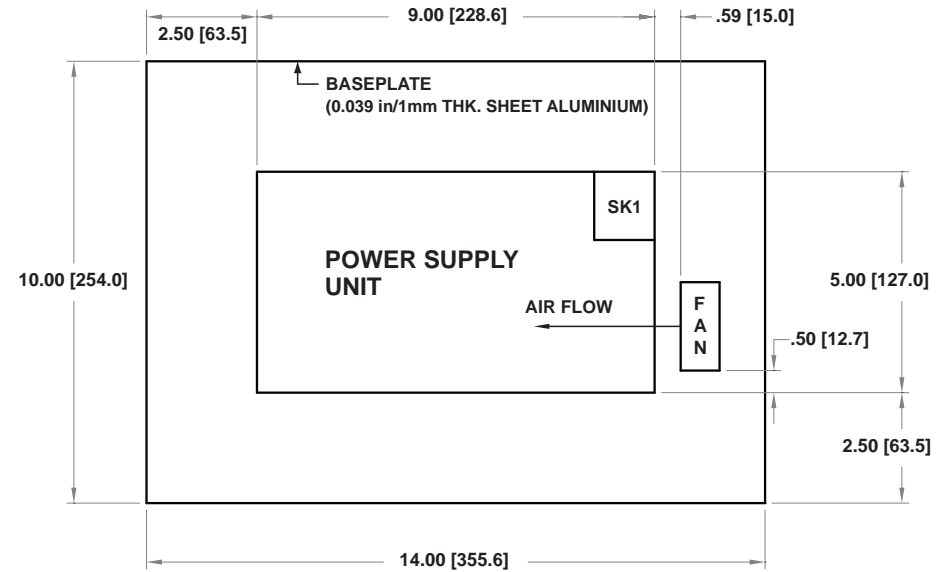

Fan Used: Minebea 2410ML-04W-B60, 12 V dc, 0.40 A

Dc Input for Fan Testing: 12 V dc

NOTE: Dimensions and fan used are for reference only

Output	
Maximum power	With cover: 250 W with 30 CFM forced air, (-C) (-CF) (CEF)
Adjustment range	±5% min. on main: 5-25 V on 4th output
Supervisory outputs	5 V @ 100 mA regulated, 12 V @ 500 mA
Hold-up time	16 ms @ 250 W load, 115 Vac nominal line
Overload protection	Short circuit protection on all outputs. Case overload protected @ 110-145% above peak rating
Overvoltage protection	5 V output: 5.7 to 6.7 Vdc; Other models 10% to 25% above nominal output
Minimum load	3 A for 1st output
Logic Control	
Power failure	TTL logic signal goes high 50-150 msec after 5 V output. It goes low at least 4 msec before loss of regulation
Remote on/off	Requires an external contact (N.O. or N.C.) to inhibit outputs
DC-OK	TTL logic goes high 50-150 msec after the output. It goes low when there is loss of regulation
Remote sense	Compensates for 0.5 V lead drop minimum, will operate without remote sense connected. Reverse connection protected.

Environmental Specifications

Operating temperature	0° to 50°C ambient. Derate each output at 2.5% per degree from 50° to 70°C
Storage temperature	-40°C to 85°C
Temperature coefficient	±0.4% per °C
Electromagnetic susceptibility	Designed to meet IEC 801, -2, -3, -4, -5, -6, Level 3
Humidity	Operating; non-condensing 5% to 95%
Vibration	Three orthogonal axes, sweep at 1 oct/min, 5 min. dwell at four major resonances 0.7 G peak 5Hz to 500Hz, operational
MTBF demonstrated	>550,000 hours at full load and 25°C ambient conditions

Mating Connectors

SK3	Molex 22-01-1084 PINS: 08-70-0057
SK4	Molex 22-01-3027 PINS: 08-50-0114
SK5	Molex 22-01-3027 PINS: 08-50-0114
SK7	Molex 22-01-3027 PINS: 08-50-0114

Connector Kit #70-841-005, includes all of the above

1. Specifications subject to change without notice.
2. All dimensions in inches (mm), tolerance is ±0.02".
3. Specifications are at factory settings unless otherwise stated.
4. To enable normally closed remote inhibit, cut jumper J1.
5. Mounting maximum insertion depth is 0.12".
6. Warranty: 2 year
7. Weight: 3.1 lbs/1.41 kg



Phone: (800) 377-4384
Email: tech@solahd.com
www.solahd.com

To comply with the published safety standards, the following must be observed when using this power supply:

1. Maximum ambient temperature for the power supply must not exceed 50°C.
2. When installing the power supply in the end-use equipment, special attention is required to ensure safety compliance with the following safety standards: UL60950-1, EN60950-1, IEC60950-1, and CSA22.2 No. 60950-1-03; including the requirements for creepage distances, clearances, and distance through insulation between primary wiring and earth or secondary (SELV) wiring.
3. The power supply's rated input voltage is automatically selected. Please refer to the specification sheet for the input voltage range.
4. The maximum output power of the supply must not exceed the rating indicated in the specification sheet.
5. This unit contains a secondary output exceeding 240 VA. When installing the unit into the end system, make sure the secondary output and the appropriate wire cannot be touched.
6. The earth ground wire must be connected only to the point marked with the earth ground symbol (on the unit).
7. The disconnection from the line must be in the end system.
8. Hazardous voltages exist in the primary circuits. Disconnect the power supply before servicing.
9. When operating with a dc input voltage range, the unit input must be protected by a dc rated fuse in the end-use installation system.
10. The internal fuse should only be replaced with a F10AH, 250 V ac, type 216010 manufactured by Littelfuse or type SP001.1014 manufactured by Schurter AG.
11. This equipment is considered Class I according to protection against electric shock.
12. This power supply is **CE** marked following the provisions of the Low Voltage Directive, 2006/95/EC.
13. For technical assistance, contact SolaHD Technical Support at (800) 377-4384 or send an e-mail to tech@solahd.com. Please visit our Web site at www.solahd.com for additional product information and specification sheets.

Output Ratings

Model	Output Voltage (V)	30 CFM Forced Air Cooling (unit not convection rated)	
		Max. Output Current (A)	Max. Output Power (W)
GLQ352-C (-CEF)	+5	50.0	350 with cover
	+12	12.0	
	-12	6.0	
	+3.3 to +24	6.0	

Mechanical Outline

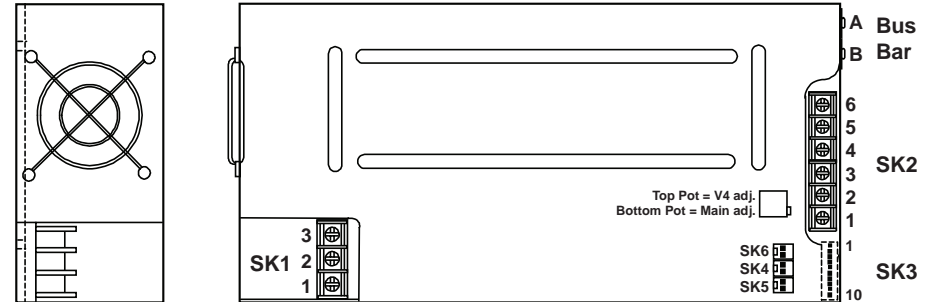

Connector PIN Designation

Input Connector	PIN	Designation
SK1	1	Neutral
	2	Line
	3	Earth GND
Output Connector	PIN	Designation
Bus Bar	A	+5 V
	B	Common
SK2	1	+12 V
	2	Common
	3	Common
	4	-12 V
	5	Return (float)
	6	+3.3 V to +24 V adj.
SK3	1	+Sense V4
	2	-Sense V4
	3	+Sense V1
	4	-Sense V1
	5	P OK
	6	C. Share
	7	Dc OK
	8	Inhibit
	9	Inhibit
	10	Common
SK4	1	+12 V (aux)
	2	Common
SK5	1	+5 V (aux)
	2	Common
SK6	1	12 V fan (+)
	2	Fan (-)

Mechanical Dimensions

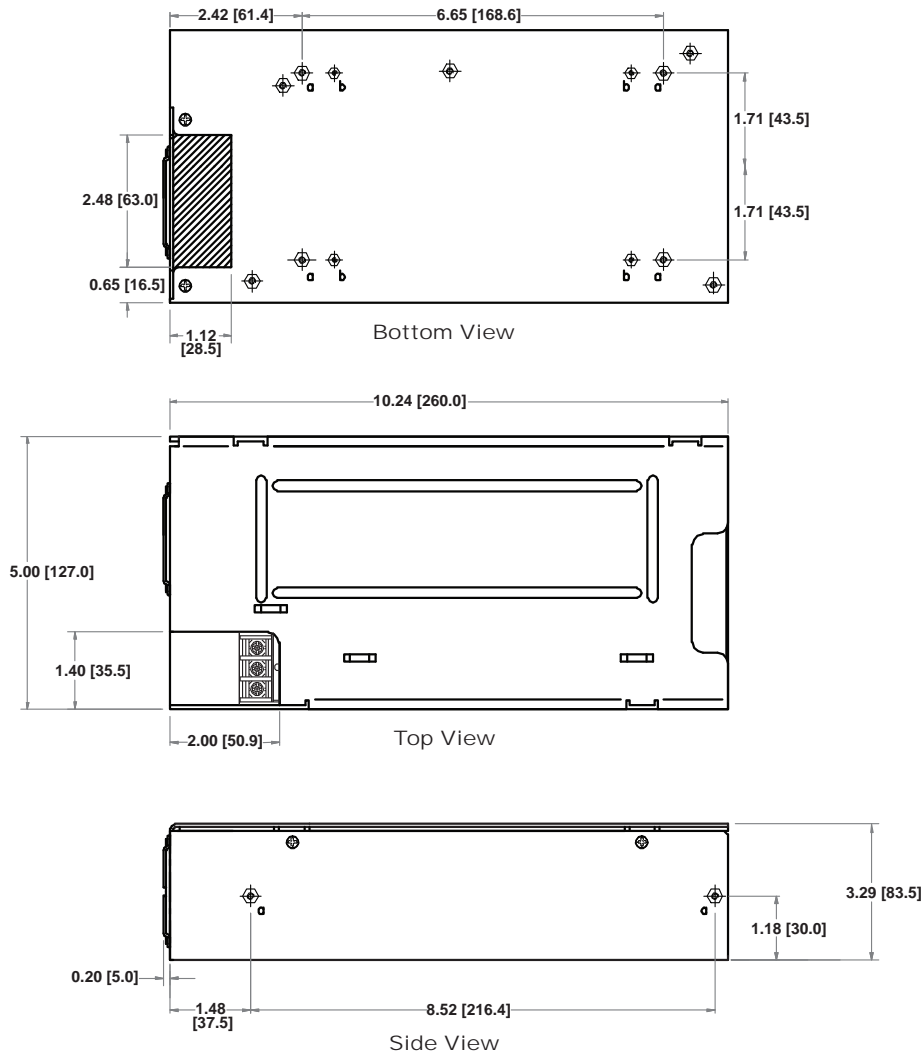

All dimensions are in inches [mm]
 Screw Size: a = #6-32 (U.S.); b = M3 (International)

Typical Ventilation Setup

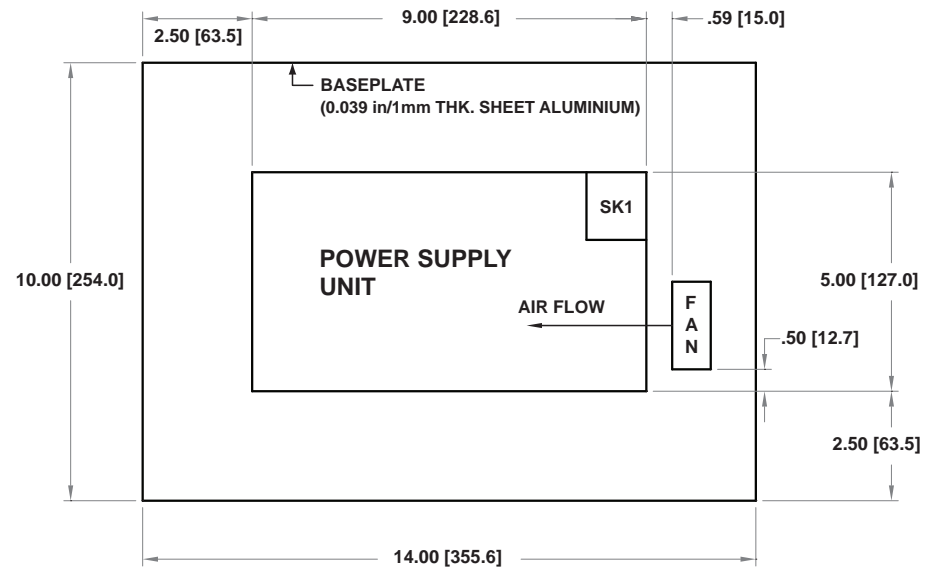

Fan Used: Minebea 2410ML-04W-B60, 12 V dc, 0.40 A
 Dc Input for Fan Testing: 12 V dc
 NOTE: Dimensions and fan used are for reference only
 NOTE: Not applicable for -CEF models

Output	
Maximum power	With cover: 350 W with 30 CFM forced air, (-C) (-CF) (-CEF)
Adjustment range	±5% min. on main: 3.3-24 V on output 4
Supervisory output	5 V @ 500 mA regulated, 12 @ 150 mA x2
Hold-up time	20 ms @ 350W load, 115 Vac nominal line
Overload protection	Short circuit protection on all outputs. Case overload protected @ 110-145% above peak rating
Overvoltage protection	5 V output: 5.7 to 6.7 Vdc
Minimum load	5 A for 1st output; 1 A for 4th output (minimum load required when the output is set below 5 V)
Logic Control	
Power failure	TTL logic signal goes high 50-150 msec after 5 V output. It goes low at least 4 msec before loss of regulation
Remote on/off	Requires an external contact (N.O. or N.C.) to inhibit outputs
DC-OK	TTL logic goes high 50-150 msec after 5 V output. It goes low when there is loss of regulation.
Remote sense	Compensates for 0.5 V lead drop minimum, will operate without remote sense connected. Reverse connection protected

Environmental Specifications

Operating temperature	0° to 50°C ambient. Derate each output at 2.5% per degree from 50° to 70°C
Storage temperature	-40°C to 85°C
Temperature coefficient	±0.04% per °C
Electromagnetic susceptibility	Designed to meet IEC 801, -2, -3, -4, -5, -6, Level 3
Humidity	Operating; non-condensing 5% to 95%
Vibration	Three orthogonal axes, sweep at 1 oct/min, 5 min. dwell at four major resonances 0.7 G peak 5Hz to 500Hz, operational
MTBF demonstrated	>550,000 hours at full load and 25°C ambient conditions

Mating Connectors

SK3	Molex 22-01-1084 PINS: 08-70-0057
SK4	Molex 22-01-3027 PINS: 08-50-0114
SK5	Molex 22-01-3027 PINS: 08-50-0114
SK6	Molex 22-01-3027 PINS: 08-50-0114

Connector Kit #70-841-011, includes all of the above

1. Specifications subject to change without notice.
2. All dimensions in inches (mm), tolerance is ±0.02”.
3. Specifications are at factory settings unless otherwise stated.
4. To enable normally closed remote inhibit, cut jumper J1.
5. Mounting (6-32) maximum insertion depth is .12”.
6. Warranty: 1 year
7. Weight: 4 lbs/1.8 kg



Phone: (800) 377-4384
Email: tech@solahd.com
www.solahd.com



GLS100-M Series Installation & Operating Instructions

To comply with the published safety standards, the following must be observed when using this power supply:

- Maximum ambient temperature for the power supply must not exceed 50°C. Derate each output 2.5% per degree from 50°C to 70°C ambient temperature.
- When installing the power supply in the end-use equipment, special attention is required to ensure safety compliance with the following safety standards: UL60950-1, EN60950-1, IEC60950-1, CSA22.2 No. 60950-1-03, UL60601-1, EN60601-1, IEC60601-1, and CSA22.2 No. 601.1. The safety requirements include creepage distances, clearances, and distance through insulation between primary wiring and earth or secondary (SELV) wiring.
- The ac-dc input connector is approved as a component of the power supply, however, it was not specifically evaluated to IEC60320.
- This power supply is approved and certified for the rated voltage range of 100 V ac to 250 V ac and/or 120 V dc minimum to 300 V dc maximum.
- The maximum output power of the supply must not exceed the rating indicated in the specification sheet.
- The earth ground wire must be connected only to the point marked with the earth ground symbol (on the unit).
- The disconnection from the line must be in the end system.
- Hazardous voltages exist in the primary circuits. Disconnect power supply before servicing.
- When operating with a dc input voltage range, the unit input must be protected by a dc rated fuse in the end-use installation system.
- The internal fuses (F1 & F2) should only be replaced with a F2A5, 250 V ac, type 392 manufactured by Wickmann or type RST manufactured by Belfuse.
NOTE: The power supply has a fuse on the neutral line.
- The power supply has no patient applied part.
- This equipment is considered Class I according to protection against electric shock.
- This power supply is **CE** marked following the provisions of the Low Voltage Directive, 2006/95/EC.
- For technical assistance, contact SolaHD Technical Support at (800) 377-4384 or send an e-mail to tech@solahd.com. Please visit our Web site at www.solahd.com for additional product information and specification sheets.

Output Ratings

Model	Output Voltage (V)	Convection Cooling		30 CFM Forced Air Cooling	
		Max. Output Current (A)	Max. Output Power (W)	Max. Output Current (A)	Max. Output Power (W)
GLS102-M	+5	16.0	80	24.0	120
	+12_FAN	0.5		1.0	
GLS103-M	+12	8.3	100	12.5	150
	+12_FAN	0.5		1.0	
GLS104-M	+15	6.7		10.0	
	+12_FAN	0.5		1.0	
GLS105-M	+24	4.2		6.25	
	+12_FAN	0.5		1.0	
GLS108-M	+48	2.09		3.1	
	+12_FAN	0.5		1.0	

Connector PIN Designation

Input Connector	PIN	Designation
SK1	1	Neutral
	3	Line
CN1		GND
Output Connector	PIN	Designation
SK2	1	Common
	2	
	3	
	4	
	5	+Vout
	6	
	7	
	8	
SK203	1	GND
	2	Power fail
	3	-Remote sense
	4	+Remote sense
SK5	1	+12 V_FAN
	2	+12 V_FAN
	3	Common fan
	4	Common fan

Mechanical Outline & Dimensions

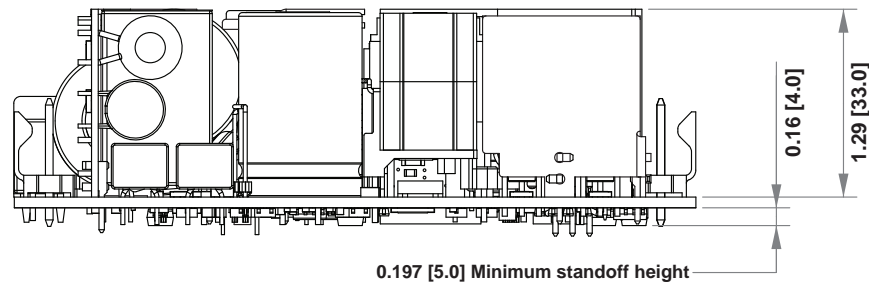
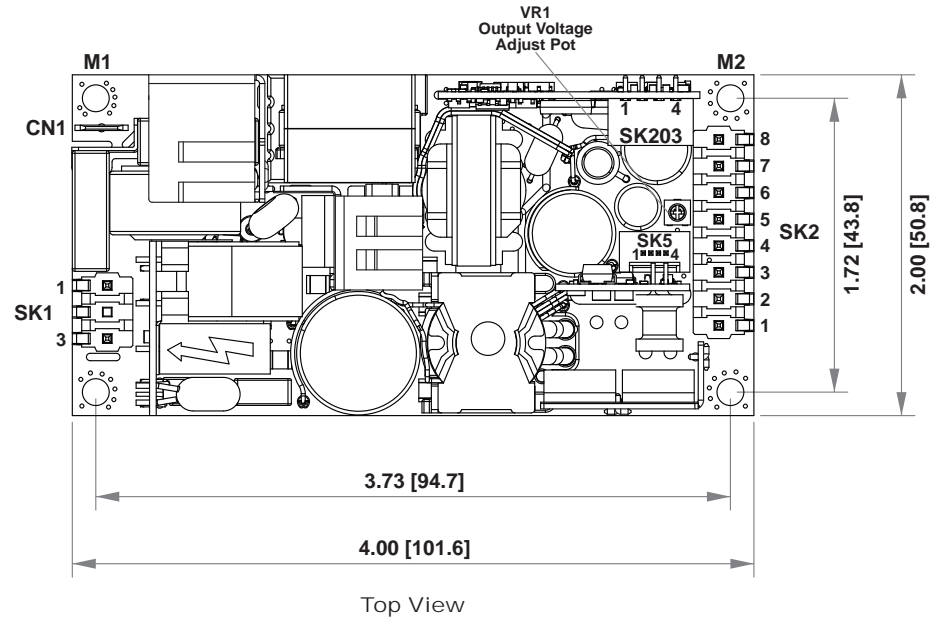

- All dimensions are in inches [mm]
- Mounting hole diameter (4X) = 0.16" [4.0 mm]
- Maximum screw head diameter = 0.22" [5.6 mm]
- Mounting holes M1 and M2 should be grounded for EMI purposes
- Mounting hole M1 is a safety ground connection

leakage current	
Output	
Maximum power	100 W for convection (80 W for GLS102-M); 150 W with 30 CFM forced air (120 W for GLS102-M)
Adjustment range	±10% min. on the main outputs
Fan output	12 V @ 1 A isolated, ±10%
Hold-up time	10 ms @ 150 W load, 120 Vac input
Overload protection	Short circuit protection on all outputs Case overload protected @ 110-160% above rating
Overvoltage protection	15% to 35% above nominal output
Logic Control	
Power failure	Open collector logic signal goes high 100-500 msec after main output. It goes low at least 6 msec before loss of regulation.
Remote sense	Compensates for 0.5 V lead drop min. Will operate without remote sense connected. Reverse connection protected.

Environmental Specifications

Operating temperature	0° to 50°C ambient. Derate each output 2.5% per degree from 50° to 70°C. -20°C start up
Storage temperature	-40°C to 85°C
Electromagnetic susceptibility	Designed to meet EN61000-4; -2, -3, -4, -5, -6, -8, -11 Level 3
Humidity	Operating; non-condensing 10% to 95% RH
Vibration	IEC68-2-6 to the levels of IEC721-3-2
MTBF demonstrated	>550,000 hours at full load and 25°C ambient conditions

Mating Connectors

(SK1) AC Input	Molex P/N: 09-50-8031, PINS: 08-52-0113 or Landwin P/N: 3060S0302, PINS: 3360T011P
AC Ground	Molex: 01-90020001
(SK2) DC Outputs	Molex P/N: 09-50-8081, PINS: 08-52-0113 or Landwin P/N: 3060S0802, PINS: 3360T011P
(SK203) Remote Sense	Molex P/N: 35155-0400, PINS: 08-70-0057 or Landwin P/N: 2640S04A0, PINS: 2543T011P
(SK5) Fan	Molex P/N: 22-01-1042, PINS: 08-70-0049 or Landwin P/N: 2510S04A0, PINS: 2543T011P

Connector Kit #70-841-025, includes all of the above

1. Specifications subject to change without notice.
2. All dimensions in inches (mm), tolerance is ±0.02" (±0.5mm).
3. Specifications are for convection rating at factory settings at 115 Vac input 25°C unless otherwise stated.
4. Mounting holes MH1 and MH2 should be grounded for EMI purposes.
5. Mounting hole MH1 is safety ground connection.
6. This power supply requires mounting on metal standoffs 0.20" (5 m) in height.
7. Warranty: 2 year
8. Weight: 0.44 lb/0.20 kg



Phone: (800) 377-4384
 Email: tech@solahd.com
 www.solahd.com

To comply with the published safety standards, the following must be observed when using this power supply:

1. Maximum ambient temperature for the power supply must not exceed 50°C.
2. When installing the power supply in the end-use equipment, special attention is required to ensure safety compliance with the following safety standards: UL60950-1, EN60950-1, IEC60950-1, and CSA22.2 No. 234-M90; including the requirements for creepage distances, clearances, and distance through insulation between primary wiring and earth or secondary (SELV) wiring.
3. The power supply's rated input voltage is automatically selected. Please refer to the specification sheet for the input voltage range.
4. The maximum output power of the supply must not exceed the rating indicated in the specification sheet.
5. The earth ground wire must be connected only to the point marked with the earth ground symbol (on the unit).
6. Hazardous voltages exist in the primary circuits. Disconnect the power supply before servicing.
7. When operating with a dc input voltage range, the dc source must be rectified from a mains supply not exceeding 250 V ac. The unit input must also be protected by a dc rated fuse in the end-use installation system.
8. The internal fuse should only be replaced with a 4 A, 250 V ac, Type SP0001.1010 manufactured by Schurter AG, Type 216004 manufactured by Littelfuse or Type S501 manufactured by Cooper.
9. This equipment is considered Class I according to protection against electric shock.
10. This power supply is **CE** marked following the provisions of the Low Voltage Directive, 2006/95/EC.
11. For technical assistance, contact SolaHD Technical Support at (800) 377-4384 or send an e-mail to tech@solahd.com. Please visit our Web site at www.solahd.com for additional product information and specification sheets.

Output Ratings

Model	Output Voltage (V)	Convection Cooling		30 CFM Forced Air Cooling	
		Calculated Max. Output Current (A)	Max. Output Power (W)	Max. Output Current (A)	Max. Output Power (W)
GLS114	+15	5.3	80	7.3	110
GLS115	+24	3.3		4.6	

Mechanical Outline & Dimensions

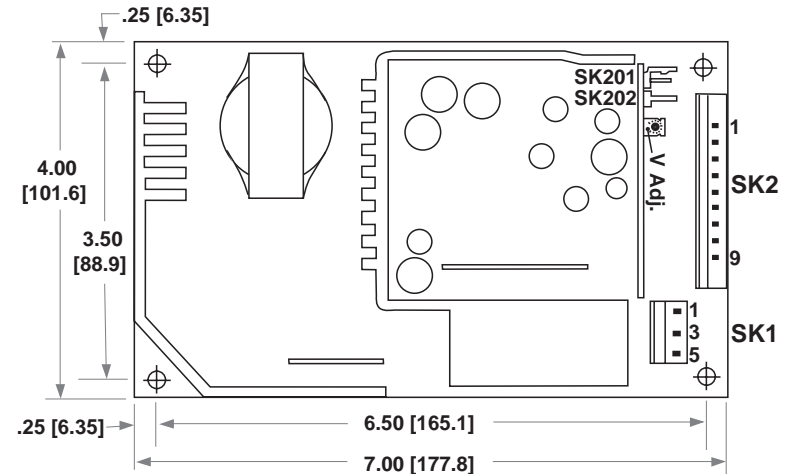

Connector PIN Designation

Input Connector	PIN	GLS114	GLS115
SK1	1	GND	
	3	Neutral	
	5	Line	
Output Connector	PIN	GLS114	GLS115
SK2	1	+15 V	+24 V
	2		
	3		
	4	Common	
	5		
	6		
	7	+15 V	+24 V
	8		
	9		
SK201	1	+Sense	
	2	-Sense	
SK202	1	P OK	
	2	GND	

Mechanical Dimensions

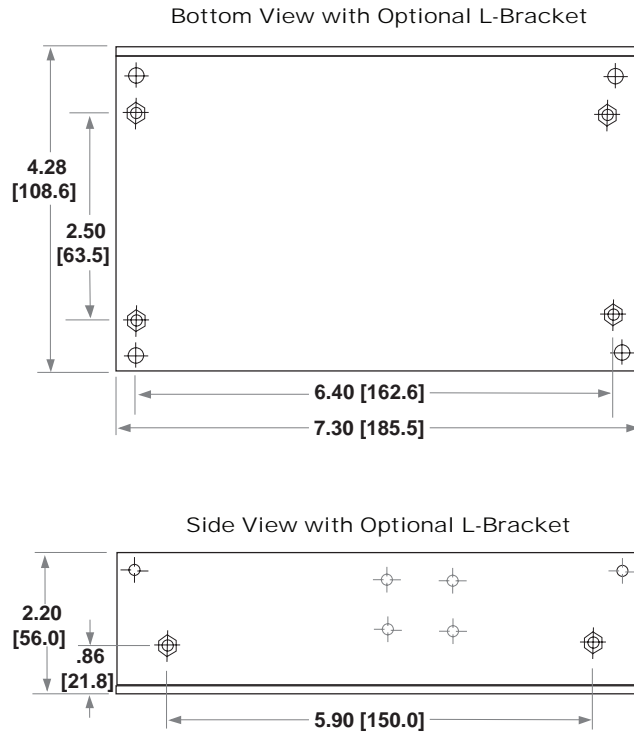

All dimensions are in inches [mm]
Screw size: #6-32

Typical Ventilation Setup

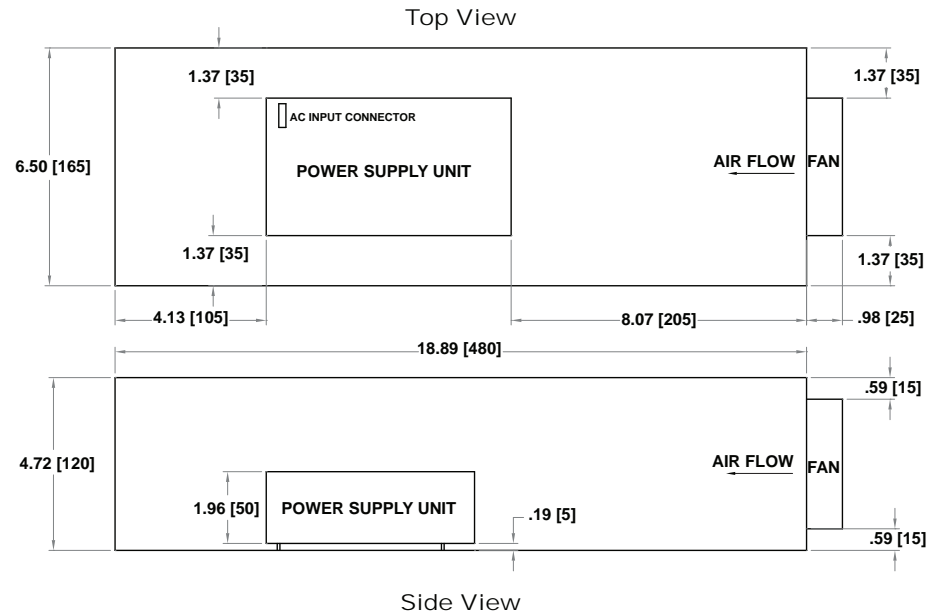

Fan Used: MINEBEA 3610NL-04W-B30, 12 V dc, 0.23 A
Dc Input for Fan During Testing: 12 V dc
NOTE: Dimensions and fan used are for reference only

Safety ground leakage current	<0.5 mA @ 50/60 Hz, 264 Vac input
-------------------------------	-----------------------------------

Output	
Maximum power	80 W for convection; 110 W with 30 CFM forced air
Adjustment range	±5% min.
Hold-up time	20 ms @ 80 W load, 115 Vac nominal line
Overload protection	Short circuit protection on all outputs Case overload protected @ 110-145% above peak rating
Overvoltage protection	5 V output; 5.7 to 6.7 Vdc; Other outputs 10% to 20% above nominal output; Latching type, recycle AC to reset
Logic Control	
Power failure	TTL logic signal goes high 50-150 msec after main output. It goes low at least 4 msec before loss of regulation.
Remote sense	Compensates for 0.5 V lead drop min. Will operate without remote sense connected. Reverse connection protected.

Environmental Specifications

Operating temperature	0° to 50°C ambient. Derate each output 2.5% per degree from 50° to 70°C
Storage temperature	-40°C to 85°C
Temperature coefficient	±0.04% per °C
Electromagnetic susceptibility	Designed to meet IEC 801, -2, -3, -4, -5, -6, Level 3
Humidity	Operating; non-condensing 5% to 95%
Vibration	Three orthogonal axes, sweep at 1 oct/min., 5 min. dwell at four major resonances 0.75G peak 5Hz to 500Hz, operational
MTBF demonstrated	>550,000 hours at full load and 25°C ambient conditions

Mating Connectors	
AC Input	Molex 09-50-8051 (USA) 09-91-0500 (UK); PINS: 08-58-0111
DC Outputs	Molex 09-50-8091 (USA) 09-91-0900 (UK); PINS: 08-58-0111
Remote Sense/ Power Fail	Molex 22-01-1022 (USA) 22-01-1023 (UK); PINS: 08-50-0114

Connector Kit #70-841-007, includes all of the above

1. Specifications subject to change without notice.
2. All dimensions in inches (mm), tolerance is ±0.02" (±0.5mm).
3. Specifications are for convection rating at factory settings unless otherwise stated.
4. Mounting holes M1 and M2 should be grounded for EMI purposes.
5. Mounting hole M1 is safety ground connection.
6. L bracket mounting (6-32) maximum insertion depth is .20".
7. Warranty: 2 year
8. Weight: 1.25 lbs/0.57 kg



Phone: (800) 377-4384
Email: tech@solahd.com
www.solahd.com

To comply with the published safety standards, the following must be observed when using this power supply:

- Maximum ambient temperature for the power supply must not exceed 50°C. Derate each output 2.5% per degree from 50°C to 70°C ambient temperature.
- When installing the power supply in the end-use equipment, special attention is required to ensure safety compliance with the following safety standards: UL60950-1, EN60950-1, IEC60950-1, and CSA22.2 No. 60950-1-03; including the requirements for creepage distances, clearances and distance through insulation between primary wiring and earth or secondary (SELV) wiring.
- The ac-dc input connector is approved as a component of the power supply, however, it was not specifically evaluated to IEC60320.
- This power supply is approved and certified for the rated voltage range of 100 V ac to 250 V ac and/or 120 V dc (minimum) to 300 V dc (maximum).
- The maximum output power of the supply must not exceed the rating indicated in the specification sheet.
- The earth ground wire must be connected only to the point marked with the earth ground symbol (on the unit).
- The disconnection from the line must be in the end system.
- Hazardous voltages exist in the primary circuits. Disconnect power supply before servicing.
- When operating with a dc input voltage range, the dc source must be rectified from a mains supply not exceeding 250 V ac. The unit input must also be protected by a dc rated fuse in the end-use installation system.
- The internal fuse (F1) should only be replaced by a 4AH, 250 V ac, type GDA-V/S501 manufactured by Bussmann, type 216004.MXEP manufactured by Littelfuse, or type 19194 manufactured by Wickmann.
- This equipment is considered Class I according to protection against electric shock.
- This power supply is marked following the provisions of the Low Voltage Directive, 2006/95/EC.
- For technical assistance, contact SolaHD Technical Support at (800) 377-4384 or send an e-mail to tech@solahd.com. Please visit our Web site at www.solahd.com for additional product information and specification sheets.

Mechanical Outline

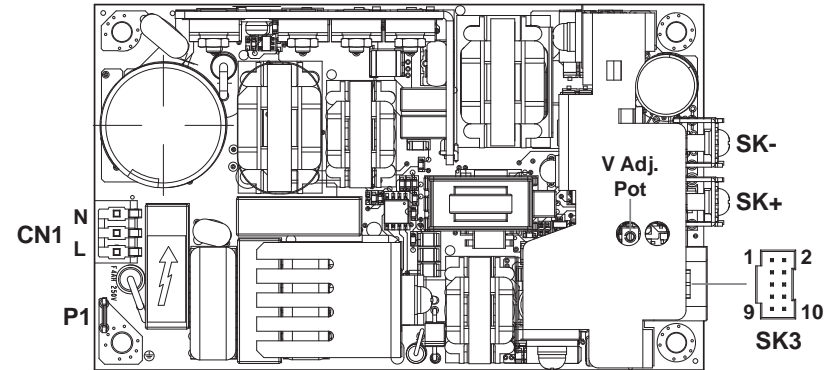

Connector PIN Designation

Input Connector	PIN	Designation
CN1		Neutral
		Line
P1		Earth
Output Connector	PIN	Designation
SK-		Common
SK+		Main output
SK3	1	+Power fail
	2	+5 VSTBY
	3	-Remote inhibit
	4	+12 V common
	5	+Remote inhibit
	6	+12 V (FAN_OUT)
	7	-Remote sense
	8	SWP (Single wire parallel)
	9	+Remote sense
	10	Common

Output Ratings

Model	Output Voltage (V)	Convection Cooling		30 CFM Forced Air Cooling	
		Max. Output Current (A)	Max. Output Power (W)	Max. Output Current (A)	Max. Output Power (W)
GLS122	+5	16.0	80	26.0	130
	+12 (FAN_OUT)	0.5		0.5	
	+5 VSTBY	0.5		0.5	
GLS123	+12	6.7		10.8	
	+12 (FAN_OUT)	0.5		0.5	
	+5 VSTBY	0.5		0.5	

Mechanical Dimensions

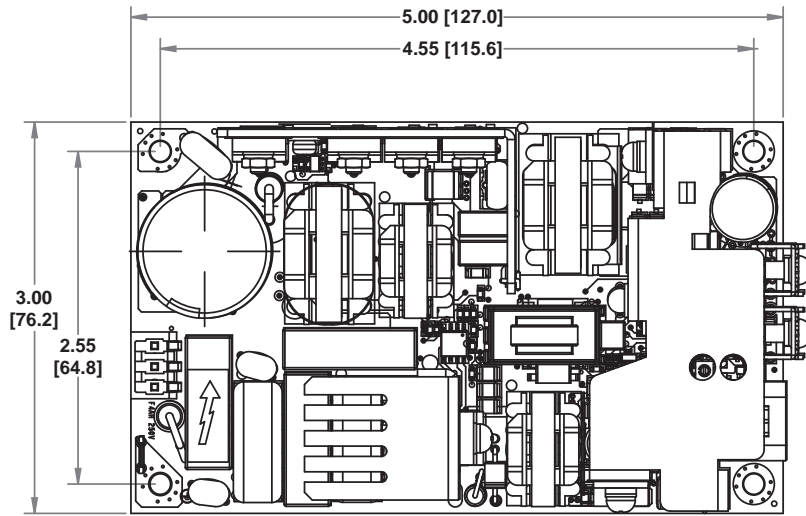

Top View

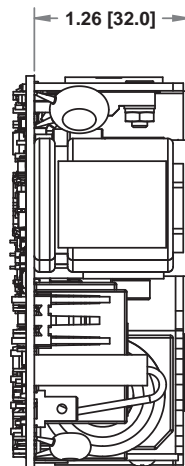

Side View

All dimensions are in inches [mm]
 Mounting hole diameter (4X): 0.15" [3.81 mm]

Typical Ventilation Setup

Option 1

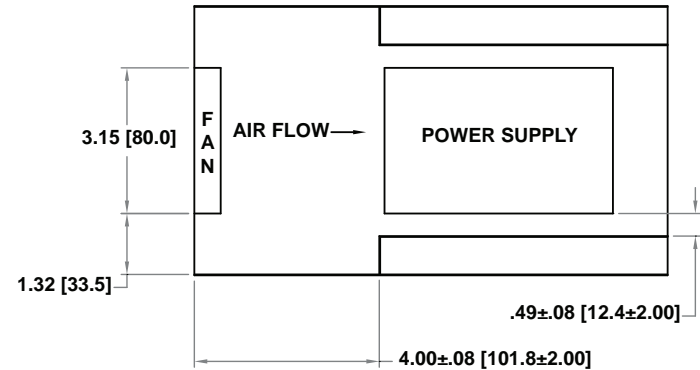

Top View

Option 2

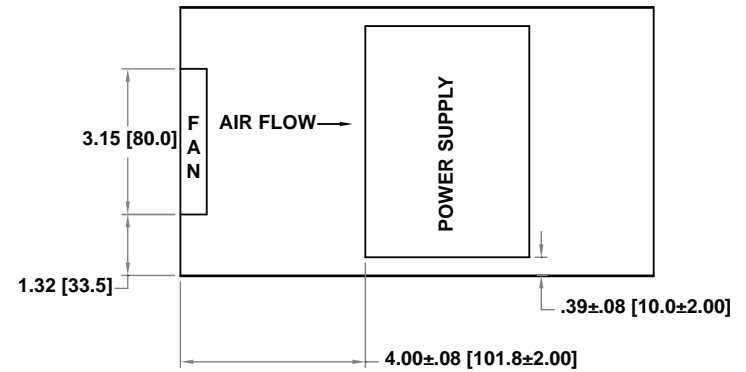

Top View

Cooling Fan: Use one 12 V dc fan or equivalent with minimum 30 CFM blowing lengthwise or sideways

NOTE: Dimensions and fan used are for reference only

safety ground leakage current	<0.5 mA @ 50/60 Hz, 264 Vac input
-------------------------------	-----------------------------------

Output	
Maximum power	80 W for convection; 130 W with 30 CFM forced air
Adjustment range	±5% min. on the main outputs
Fan output	12 V @ 500 mA - 5%, +7%
Standby outputs	5 V @ 500 mA ± 5%
Hold-up time	20 ms @ 125 W load, 120 Vac input
Overload protection	Short circuit protection on all outputs Case overload protected @ 120-135% above rating
Overvoltage protection	20% to 35% above nominal output
Logic Control	
Power failure	TTL logic signal goes high 100-500 msec after main output. It goes low at least 4 msec before loss of regulation.
Remote inhibit	Requires a contact closure to disable the outputs, except 5 V standby.
Remote sense	Compensates for 0.5 V lead drop min. Will operate without remote sense connected. Reverse connection protected.

Environmental Specifications

Operating temperature	0° to 50°C ambient. Derate each output as 2.5% per degree from 50° to 70°C. -20°C start up
Storage temperature	-40°C to 85°C
Electromagnetic susceptibility	Designed to meet EN61000-4; -2, -3, -4, -5, -6, -8, -11 Level 3
Humidity	Operating; non-condensing 10% to 95% RH
Vibration	IEC68-2-6 to the levels of IEC721-3-2
MTBF demonstrated	>550,000 hours at full load and 25°C ambient conditions

Mating Connectors	
(SK1) AC Input	Molex 09-50-8031; PINS: 08-52-0113
(SK2) DC Outputs	Molex 19141-0058/0063 Spade lug
(SK3) Control Signals	Molex 90142-0010 (USA); PINS: 90119-2110 or Amp: 87977-3; PINS: 87309-8

Connector Kit #70-841-020, includes all of the above

1. Specifications subject to change without notice.
2. All dimensions in inches (mm), tolerance is ±0.02" (±0.5mm).
3. Specifications are for convection rating at factory settings at 115 Vac input 25°C ,unless otherwise stated.
4. Mounting holes MH1, MH2 and MH3 should be grounded for EMI purposes.
5. Mounting MH1 is safety ground connection.
6. This power supply requires mounting on metal standoffs 0.20" (5m) in height.
7. Warranty: 2 year
8. Weight: 0.71 lb/0.32 kg



Phone: (800) 377-4384
Email: tech@solahd.com
www.solahd.com

SOLAHD GLS150 Series Installation & Operating Instructions

Installation & Safety

To comply with the published safety standards, the following must be observed when using this power supply:

1. Maximum ambient temperature for the power supply must not exceed 50°C.
2. When installing the power supply in the end-use equipment, special attention is required to ensure safety compliance with the following safety standards: UL60950-1, EN60950-1, IEC60950-1, and CSA22.2 No. 60950-1-03; including the requirements for creepage distances, clearances, and distance through insulation between primary wiring and earth or secondary (SELV) wiring.
3. The power supply's rated input voltage is automatically selected. Please refer to the specification sheet for the input voltage range.
4. The maximum output power of the supply must not exceed the rating indicated in the specification sheet.
5. The earth ground wire must be connected only to the point marked with the earth ground symbol (on the unit).
6. Hazardous voltages exist in the primary circuits. Disconnect the power supply before servicing.
7. When operating with a dc input voltage range, the unit input must be protected by a dc rated fuse in the end-use installation system.
8. The internal fuse should only be replaced with a 5 A, 250 V ac, type SP0001.1011 manufactured by Schurter AG, type 216005 manufactured by Littelfuse or type S501 manufactured by Cooper.
9. This power supply is **CE** marked following the provisions of the Low Voltage Directive, 2006/95/EC.

For technical assistance, contact SolaHD Technical Support at (800) 377-4384 or send an e-mail to tech@solahd.com. Please visit our Web site at www.solahd.com for additional product information and specification sheets.

Output Ratings

Model	Output Voltage (V)	Convection Cooling		30 CFM Forced Air Cooling	
		Max. Output Current (A)	Max. Output Power (W)	Max. Output Current (A)	Max. Output Power (W)
GLS152	+5	22.0	75 with cover 110 without cover	30.0	130 with cover 150 without cover
GLS153	+12 to +15	9.1		12.5	
GLS155	+24 to +28	4.5		6.2	

Mechanical Outline

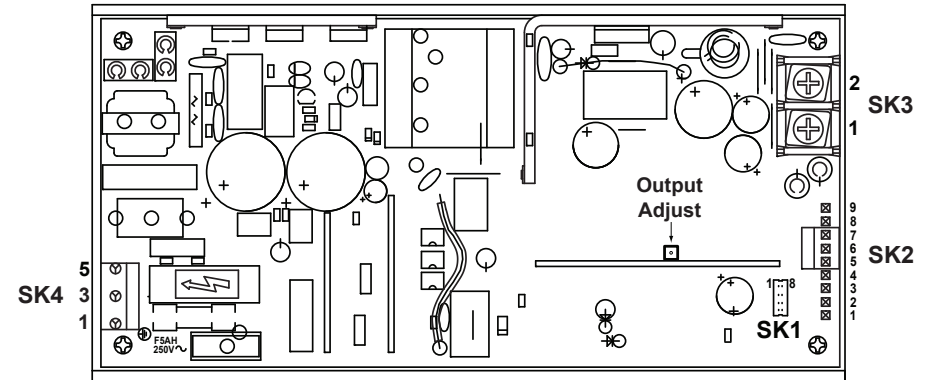

Connector PIN Designation

Output Connector	PIN	GLS152	GLS153	GLS155
SK1	1	Inhibit -ve		
	2	Inhibit +ve		
	3	Secondary Vcc		
	4	No connection		
	5	Common		
	6	-Sense		
	7	+Sense		
	8	C-Share		
SK2	1, 2, 3, 4, 8, 9	Not used		
	5	Common		
	6	No connection		
	7	P OK		
SK3	T.B. 2	+5 V	+12 V to +15 V	+24 V to +28 V
	T.B. 1	Common		
Input Connector	PIN	GLS152	GLS153	GLS155
SK4	1	Earth GND		
	2	PIN removed		
	3	Line		
	4	PIN removed		
	5	Neutral		

SOLAHD GLS150 Series Installation & Operating Instructions

Mechanical Dimensions

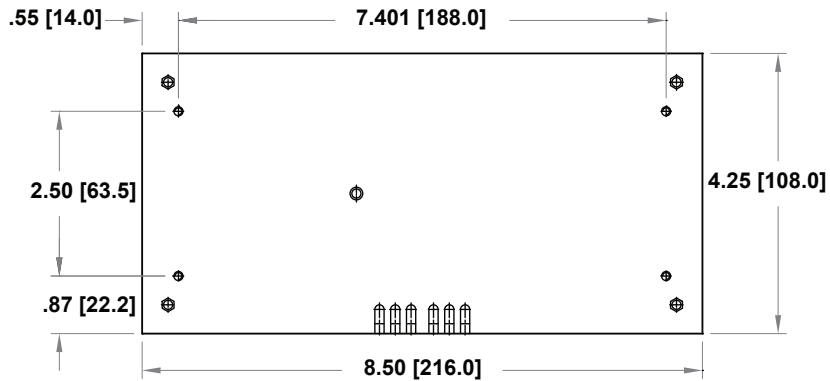

Bottom View

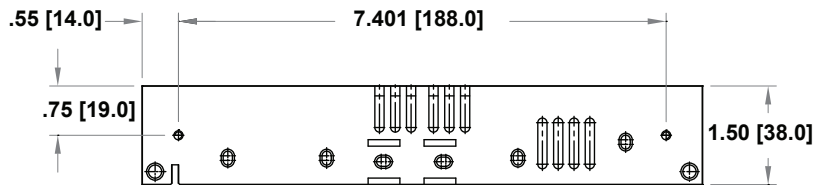

Side View

All dimensions are in inches [mm]
Screw size: #6-32

Typical Ventilation Setup

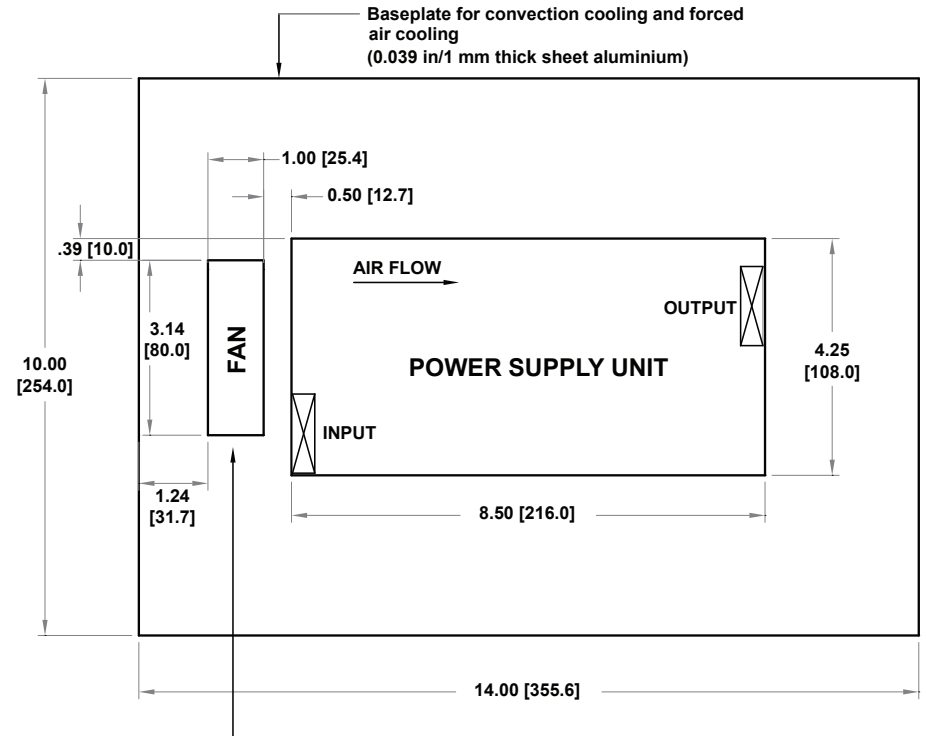

For forced air cooling only
Fan used: MINEBEA 3110NL-04W-B30, 12 V dc, 0.14 A
Dc input for fan during testing: 12 V dc

NOTE: Dimensions and fan used are for reference only



Safety ground leakage current	<0.5 mA @ 50/60 Hz, 264 Vac input
Output	
Maximum power	110 W convection (75 W with cover) 150 W with 30 CFM forced air (130 W with cover)
Adjustment range	±5% min.
Hold-up time	20 ms @ 110 W load, 115/230 Vac nominal line
Overload protection	Short circuit protection Case overload protected @ 110-145% above peak rating
Overvoltage protection	5 V output: 5.7 to 6.7 Vdc; Other outputs 10% to 25% above nominal output
Logic Control	
Power failure	TTL Logic signal goes high 50-150 msec after 5 V output. It goes low at least 3 ms before loss of regulation
Remote inhibit	Requires an external TTL high signal to inhibit outputs
Remote sense	Compensates for 0.5 V lead drop minimum, will operate without remote sense connected. Reverse connection protected

Environmental Specifications

Operating temperature	0° to 50°C ambient. Derate each output 2.5% per degree from 50° to 70°C
Storage temperature	-40°C to 85°C
Temperature coefficient	±0.04% per °C
Electromagnetic susceptibility	Designed to meet IEC 801, -2, -3, -4, -5, -6, Level 3
Humidity	Operating; non-condensing 5% to 95%
Vibration	Three orthogonal axes, sweep at 1 oct/min, 5 min. dwell at four major resonances 0.75G peak 5 Hz to 500 Hz, operational
MTBF demonstrated	>550,000 hours at full load and 25°C ambient conditions

Mating Connectors

AC Input (SK4)	Molex 09-50-8051 (USA) Molex 09-91-0500 (UK); PINS: 08-58-0111
Power Fail (SK2)	Molex 09-50-8031 (USA) Molex 09-91-0300 (UK); PINS: 08-58-0111
Remote Sense/ Remote Inhibit (SK1)	Molex 51110-0851 (USA) PINS: 50394-8100

Connector Kit #70-841-009, includes all of the above

1. Specifications subject to change without notice.
2. All dimensions in inches (mm), tolerance is ±0.02" (±0.5mm).
3. Specifications are for convection rating at factory settings unless otherwise stated.
4. Remote inhibit requires an external 5 V @ 10 mA to activate.
5. Mounting (6-32) maximum insertion depth is .12".
6. Warranty: 2 year
7. Weight: 1.75 lbs/0.80 kg



Phone: (800) 377-4384
Email: tech@solahd.com
www.solahd.com



GLS170 Series, GLS170-M Series Installation & Operating Instructions

To comply with the published safety standards, the following must be observed when using this power supply:

- Maximum ambient temperature for the power supply must not exceed 50°C. Derate each output 2.5% per degree from 50°C to 70°C ambient temperature for GLS174 and GLS175.
- When installing the power supply in the end-use equipment, special attention is required to ensure safety compliance with the following safety standards: UL60950-1, EN60950-1, IEC60950-1, and CSA22.2 No. 60950-1-03 for GLS172, GLS173, GLS174, and GLS175; UL60601-1, EN60601-1, IEC60601-1, and CSA22.2 No. 60601-1-M90 for GLS172-M, GLS173-M, GLS174-M, and GLS175-M. The safety requirements include creepage distances, clearances, and distance through insulation between primary wiring and earth or secondary (SELV) wiring.
- The ac-dc input connector is approved as a component of the power supply, however, it was not specifically evaluated to IEC60320.
- This power supply is approved and certified for the rated voltage range of 100 V ac to 250 V ac and/or 120 V dc (minimum) to 300 V dc (maximum).
- The maximum output power of the supply must not exceed the rating indicated in the specification sheet.
- The disconnection from the line must be in the end system.
- Hazardous voltages exist in the primary circuits. Disconnect power supply before servicing.
- When operating with a dc input voltage range, the unit input must be protected by a dc rated fuse in the end-use installation system.
- The internal fuse (F1) should only be replaced by a 4A, 250 V ac, type GDA-V/S501 manufactured by Bussmann, type 226004 manufactured by Littelfuse, or type 19194 manufactured by Wickmann.
- The power supply has no patient applied part.
- This equipment is considered Class I according to protection against electric shock.
- This power supply is **CE** marked following the provisions of the Low Voltage Directive, 2006/95/EC.
- For technical assistance, contact SolaHD Technical Support at (800) 377-4384 or send an e-mail to tech@solahd.com. Please visit our Web site at www.solahd.com for additional product information and specification sheets.

Output Ratings

Model	Output Voltage (V)	Convection Cooling		30 CFM Forced Air Cooling	
		Max. Output Current (A)	Max. Output Power (W)	Max. Output Current (A)	Max. Output Power (W)
GLS172 (-M)	+2.5 to +6	22.0 without cover 15.0 with cover	110 without cover 75 with cover	35.0	175 with and without cover
	+5 VSTBY	1.0		2.0	
	+12 (FAN_OUT)	0.5		1.0	
GLS173 (-M)	+6 to +12	9.1 without cover 6.25 with cover		15.0	180 with and without cover
	+5 VSTBY	1.0		2.0	
	+12 (FAN_OUT)	0.5		1.0	
GLS174 (-M)	+12 to +24	7.3 without cover 5.33 with cover		12.0	
	+5 VSTBY	1.0		2.0	
	+12 (FAN_OUT)	0.5		1.0	
GLS175 (-M)	+24 to +54	4.58 without cover 3.125 with cover		7.5	
	+5 VSTBY	1.0		2.0	
	+12 (FAN_OUT)	0.5		1.0	

Connector PIN Designation

Input Connector	PIN	Designation
SK4	1	Earth GND
	3	Line
	5	Neutral
Output Connector	PIN	Designation
SK1	1	+12 V (FAN_OUT)
	2	+5 VSTBY
	3	Common
	4	V1 SWP (Single wire parallel)
	5	Common
	6	+V1 sense
	7	Sense common
	8	Remote inhibit
	9	DC OK
	10	P OK
SK3	TB-1	Common
	TB-2	V1

Mechanical Outline & Dimensions

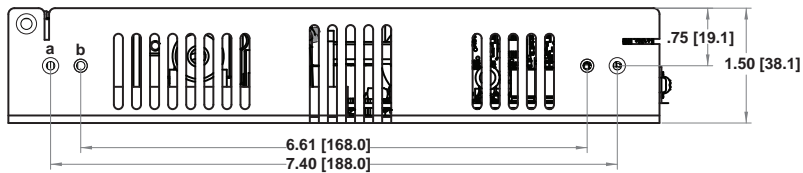
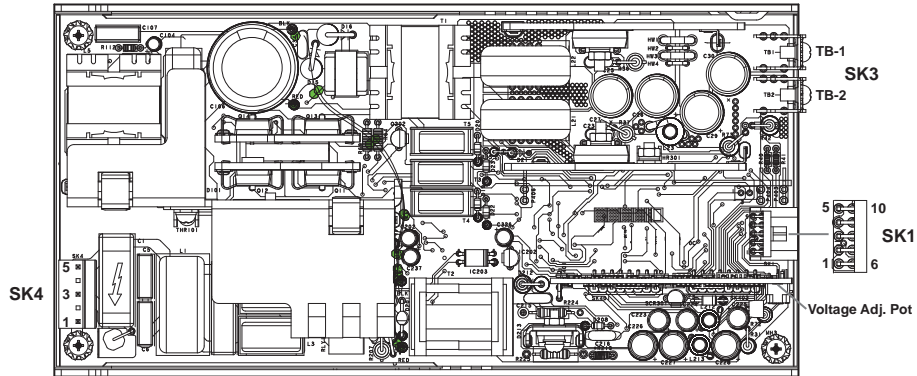

Side View

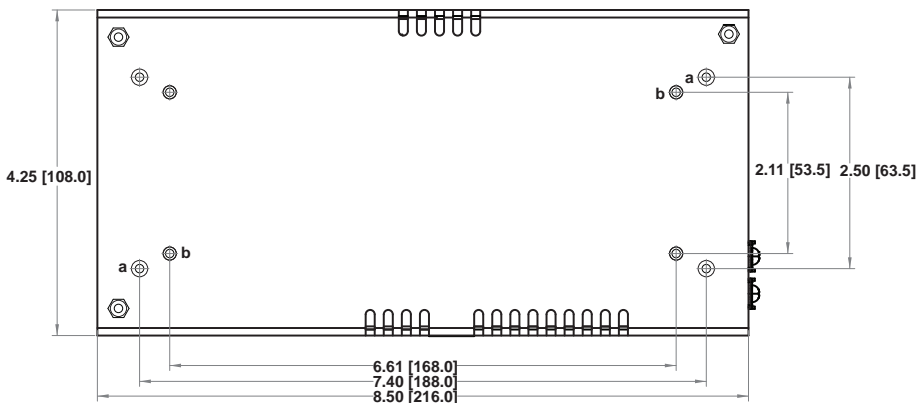

Bottom View

All dimensions are in inches [mm]
 Screw Size: a = #6-32 (U.S.); b = M3 (International)

Typical Ventilation Setup

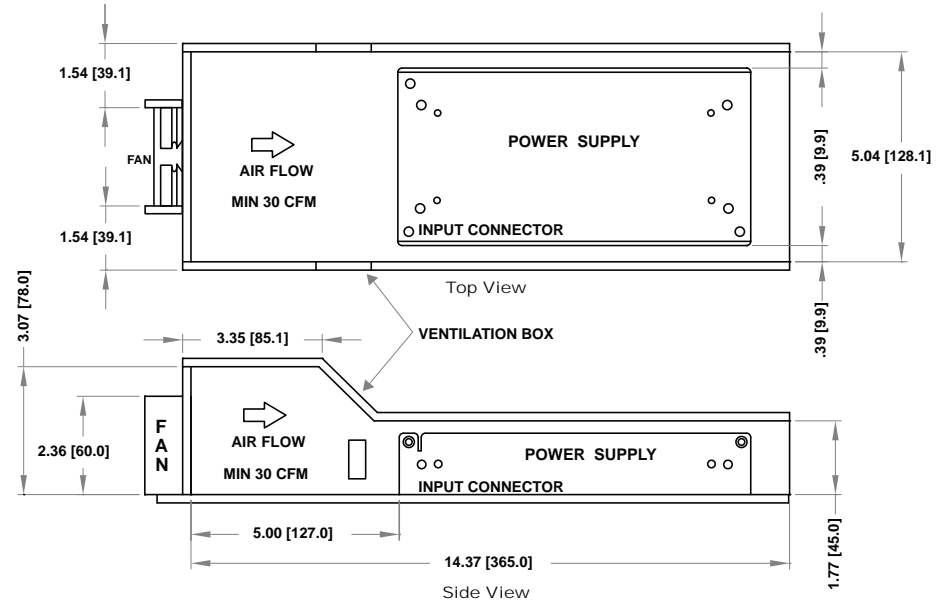

30 CFM forced air cooling

NOTE: Dimensions and fan used are for reference only

Safety ground leakage current	1.0 mA @ 50/60 Hz, 264 Vac input
Output	
Maximum power	110 W for convection (75 W with cover); 175 W with 30 CFM forced air (130 W with cover)
Adjustment range	2:1 wide ratio minimum
Standby output	5 V @ 2 A regulated \pm 5%
Hold-up time	20 ms @ 175 W load at nominal line
Overload protection	Short circuit protection on all outputs Case overload protected @ 110-145% above peak rating
Overvoltage protection	10% to 40% above nominal output
Aux output	12 V @ 1 A -5%, +10%
Logic Control	
Power failure	TTL logic signal goes high 100-500 msec after V1 output. It goes low at least 4 msec before loss of regulation.
Remote inhibit	Requires contact closure to inhibit outputs
Remote sense	Compensates for 0.5 V lead drop min. Will operate without remote sense connected. Reverse connection protected.
DC - OK	TTL logic signal goes high after main output is in regulation. It goes low when there is a loss of regulation.

Environmental Specifications

Operating temperature	0° to 50°C ambient. Derate each output 2.5% per degree from 50° to 70°C.
Low temperature start	-20°C
Storage temperature	-40°C to 85°C
Temperature coefficient	\pm 0.4% per °C
Electromagnetic susceptibility	Designed to meet IEC EN61000-4; -2, -3, -4, -5, -6, -8, -11 Level 3
Humidity	Operating; non-condensing 5% to 95%
Vibration	Three orthogonal axes, sweep at 1 oct/min., 5 min. dwell at four major resonances 0.75G peak 5Hz to 500Hz, operational
MTBF demonstrated	>550,000 hours at full load and 25°C ambient conditions

Mating Connectors

(SK4) AC Input	Molex 09-50-8051 (USA); Molex 09-91-0500 (UK) PINS: 08-58-0111
(SK3) DC Outputs	Molex 19141-0058
(SK1) Control Signals	Molex 90142-0010 (USA); PINS: 90119-2110 or Amp: 87977-3; PINS: 87309-8

Connector Kit #70-841-016, includes all of the above

1. Specifications subject to change without notice.
2. All dimensions in inches (mm), tolerance is \pm 0.02" (\pm 0.5mm).
3. Specifications are for convection rating at factory settings at 115 Vac input, 25°C unless otherwise stated.
4. Mounting holes M1 and M2 should be grounded for EMI purposes.
5. Mounting hole M1 is safety ground connection.
6. Warranty: 2 year
7. Weight: 0.5 lb/0.23 kg



Phone: (800) 377-4384
 Email: tech@solahd.com
 www.solahd.com

SOLAHD GLS20 Series Installation & Operating Instructions

Installation & Safety

To comply with the published safety standards, the following must be observed when using this power supply:

1. Maximum ambient temperature for the power supply must not exceed 50°C.
2. When installing the power supply in the end-use equipment, special attention is required to ensure safety compliance with the following safety standards: UL60950-1, EN60950-1, IEC60950-1, and CSA22.2 No. 60950-1-03; including the requirements for creepage distances, clearances, and distance through insulation between primary wiring and earth or secondary (SELV) wiring.
3. The power supply's rated input voltage is automatically selected. Please refer to the specification sheet for the input voltage range.
4. The maximum output power of the supply must not exceed the rating indicated in the specification sheet.
5. The earth ground wire must be connected only to the point marked with the earth ground symbol (on the unit).
6. Hazardous voltages exist in the primary circuits. Disconnect the power supply before servicing.
7. When operating with a dc input voltage range, the unit input must be protected by a dc rated fuse in the end-use installation system.
8. The internal fuse should only be replaced with a 2.5 A, 250 V ac, type SP0001.1008 manufactured by Schurter AG or type 21602.5 manufactured by Littelfuse.
9. This equipment is considered Class I according to protection against electric shock.
10. This power supply is **CE** marked following the provisions of the Low Voltage Directive, 2006/95/EC.

For technical assistance, contact SolaHD Technical Support at (800) 377-4384 or send an e-mail to tech@solahd.com. Please visit our Web site at www.solahd.com for additional product information and specification sheets.

Mechanical Outline

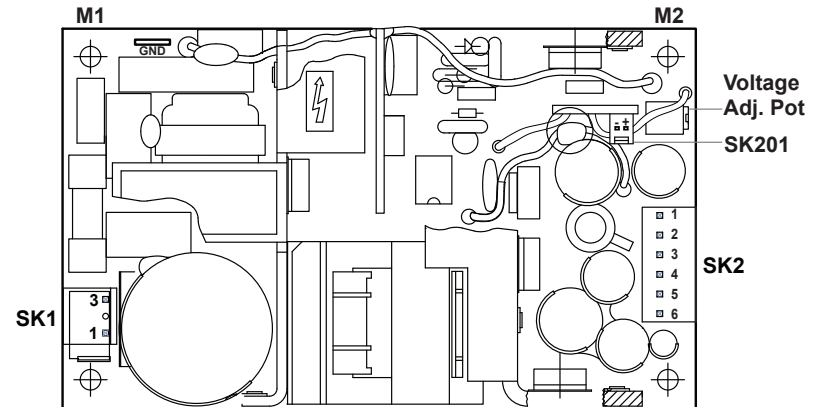

Connector PIN Designation

Input Connector	PIN	GLS22	GLS23	GLS24
SK1	1	Line		
	3	Neutral		
Output Connector	PIN	GLS22	GLS23	GLS24
SK2	1	+5 V	+12 V	+15 V
	2			
	3			
	4	Common		
	5			
	6			
SK201	1	+Sense		
	2	-Sense		

NOTE: Mounting holes M1 and M2 should be grounded for EMI purposes. Mounting hole M1 is an earth ground connection.

Output Ratings

Model	Output Voltage (V)	Convection Cooling		30 CFM Forced Air Cooling	
		Max. Output Current (A)	Max. Output Power (W)	Max. Output Current (A)	Max. Output Power (W)
GLS22	+5	5.0	25	8.0	40
GLS23	+12	2.1		3.3	
GLS24	+15	1.7		2.7	

SOLAHD GLS20 Series Installation & Operating Instructions

Mechanical Dimensions

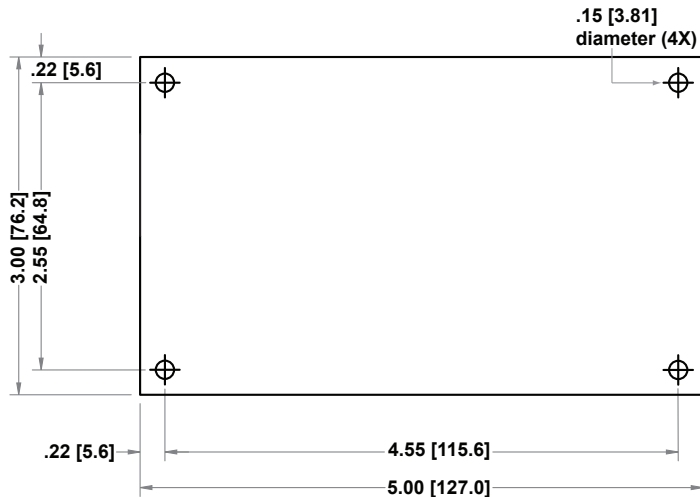

Bottom View

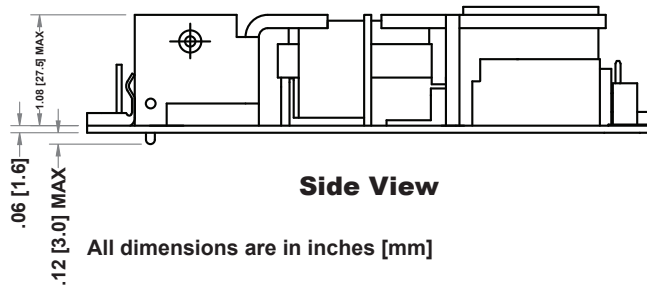

Side View

All dimensions are in inches [mm]

Typical Ventilation Setup

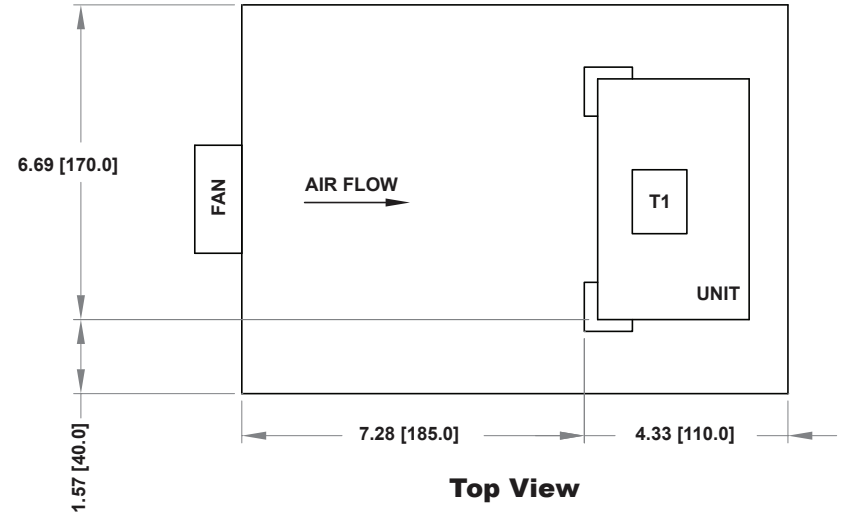

Top View

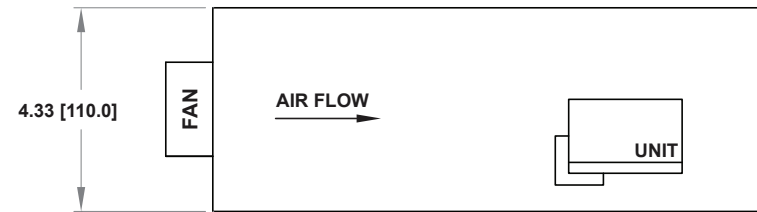

Side View

Fan: MINEBEA 3110NL-04W-B30

Fan Input: 12 V dc

NOTE: Dimensions and fan used are for reference only



Safety ground leakage current	<0.5 mA @ 50/60 Hz, 264 Vac input
-------------------------------	-----------------------------------

Output	
Maximum power	25 W for convection; 40 W with 30 CFM forced air
Adjustment range	-5, +10% minimum
Hold-up time	20 ms @ 25 W load, 115 Vac nominal line
Overload protection	Short circuit protection on all outputs Case overload protected @ 110-145% above peak rating
Overvoltage protection	5 V output; 5.7 to 6.7 Vdc. Other outputs 10% to 25% above nominal output
Remote sense	Compensates for 0.5 V lead drop minimum; Will operate without remote sense connected. Reverse connection protected.

Environmental Specifications

Operating temperature	0° to 50°C ambient. Derate each output 2.5% per degree from 50° to 70°C, -20°C start up.
Storage temperature	-40°C to 85°C
Electromagnetic susceptibility	Designed to meet IEC 801, -2, -3, -4, -5, -6, Level 3
Humidity	Operating; non-condensing 5% to 95% RH
Vibration	Three orthogonal axes, sweep at 1 oct/min, 5 min. dwell at four major resonances 0.75G peak 5 Hz to 500 Hz, operational
MTBF demonstrated	>550,000 hours at full load and 25°C ambient conditions

Mating Connectors

AC Input	Molex 09-50-8031 (USA) Not required for (-T) option 09-91-0300 (UK); PINS: 08-52-0113
DC Outputs	Molex 09-50-8061 (USA) Not required for (-T) option 09-91-0600 (UK); PINS: 08-52-0113
Remote Sense	Molex 22-01-2025; PINS: 08-52-0123

Connector Kit #70-841-006, includes all of the above

1. Specifications subject to change without notice.
2. All dimensions in inches (mm), tolerance is ± 0.02 " (± 0.5 mm).
3. Mounting holes M1 and M2 should be grounded for EMI purposes.
4. Mounting hole M1 is safety ground connection.
5. Specifications are for convection rating at factory settings at 115 Vac input, 25°C unless otherwise stated.
6. Warranty: 2 year
7. Weight: 0.5lb/0.23kg

Power Derating Curve

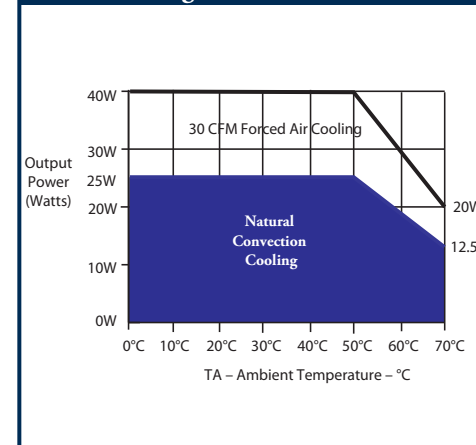



GLS200-M Series Installation & Operating Instructions

To comply with the published safety standards, the following must be observed when using this power supply:

- Maximum ambient temperature for the power supply must not exceed 50°C. Derate each output 2.5% per degree from 50°C to 70°C ambient temperature.
- When installing the power supply in the end-use equipment, special attention is required to ensure safety compliance with the following safety standards: UL60950-1, EN60950-1, IEC60950-1, CSA22.2 No. 60950-1-03, UL60601-1, EN60601-1, IEC60601-1, and CSA22.2 No. 601.1. The safety requirements include creepage distances, clearances, and distance through insulation between primary wiring and earth or secondary (SELV) wiring.
- The ac-dc input connector is approved as a component of the power supply, however, it was not specifically evaluated to IEC60320.
- This power supply is approved and certified for the rated voltage range of 100 V ac to 250 V ac and/or 120 V dc minimum to 300 V dc maximum.
- The maximum output power of the supply must not exceed the rating indicated in the specification sheet.
- The earth ground wire must be connected only to the point marked with the earth ground symbol (on the unit).
- The disconnection from the line must be in the end system.
- Hazardous voltages exist in the primary circuits. Disconnect power supply before servicing.
- When operating with a dc input voltage range, the unit must be protected by a dc rated fuse in the end-use installation system.
- The internal fuses (F1 & F2) should only be replaced with a F5AH, 250 V ac, type 50CF manufactured by Hollyland or type 216005.MXEP manufactured by Littelfuse.
NOTE: The power supply has a fuse on the neutral line.
- The power supply has no patient applied part.
- This equipment is considered Class I according to protection against electric shock.
- This power supply is **CE** marked following the provisions of the Low Voltage Directive, 2006/95/EC.
- For technical assistance, contact SolaHD Technical Support at (800) 377-4384 or send an e-mail to tech@solahd.com. Please visit our Web site at www.solahd.com for additional product information and specification sheets.

Output Ratings

Model	Output Voltage (V)	Convection Cooling		30 CFM Forced Air Cooling	
		Max. Output Current (A)	Max. Output Power (W)	Max. Output Current (A)	Max. Output Power (W)
GLS202-M	+5	20.0	100	40.0	200
	+12_FAN	0.5		1.0	
GLS203-M	+12	10.4	125	20.83	250
	+12_FAN	0.5		1.0	
GLS204-M	+15	8.3		16.6	
	+12_FAN	0.5		1.0	
GLS205-M	+24	5.2		10.4	
	+12_FAN	0.5		1.0	
GLS208-M	+48	2.6		5.2	
	+12_FAN	0.5		1.0	

Connector PIN Designation

Input Connector	PIN	Designation
SK1		Neutral
		Line
	P1	Earth GND
Output Connector	PIN	Designation
SK2	-	Common
	+	Main output
SK3	1	+Remote sense
	2	-Remote sense
	3	N/C
	4	N/C
	5	Power fail
	6	Common
	7	N/C
	8	Common
	9	+12 V_FAN
	10	+12 V_FAN return

Mechanical Outline & Dimensions

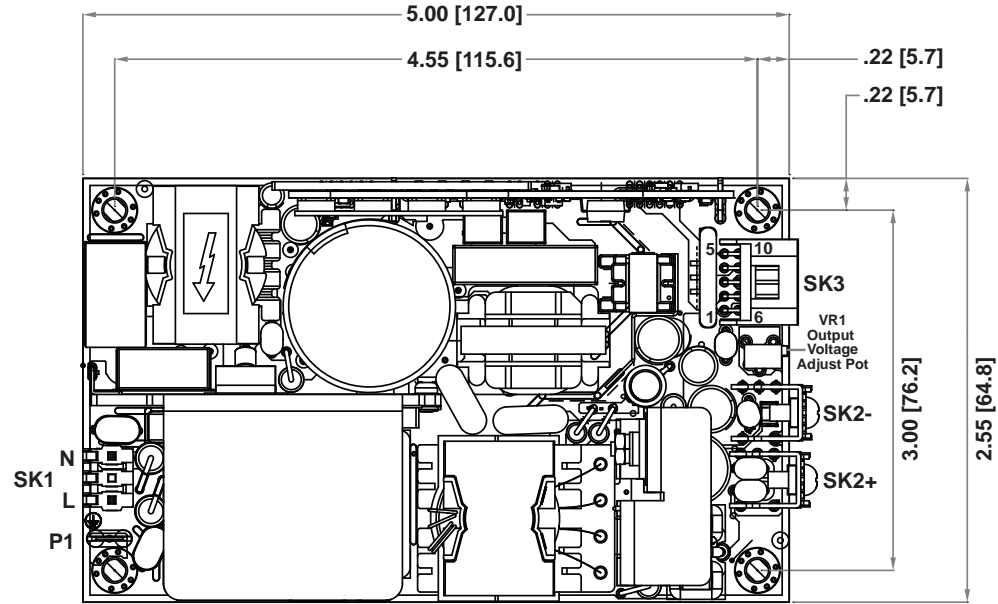

Top View

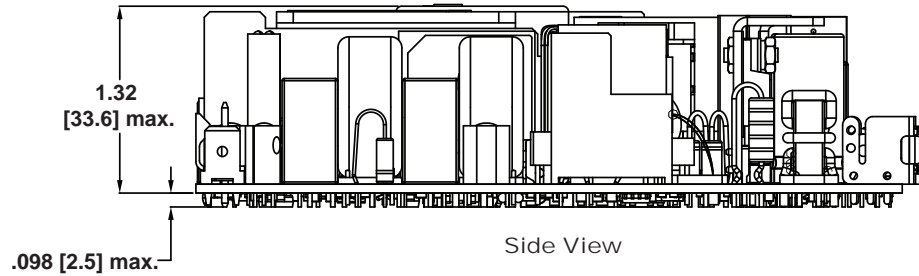

Side View

All dimensions are in inches [mm]
 Mounting hole diameter (4X) = 0.15" [3.81 mm]

safety ground leakage current	275 μ A @ 50/60 Hz, 264 Vac input
Output	
Maximum power	125 W for convection; 250 W (200 W for GLS202-M) with 30 CFM forced air
Adjustment range	\pm 10% min. on the main outputs
Fan output	12 V @ 1 A isolated, \pm 10%
Hold-up time	16 ms @ 250 W load, 120 Vac input
Overload protection	Short circuit protection on all outputs. Case overload protected @ 110-160% above peak rating
Overvoltage protection	15% to 50% above nominal output
Logic Control	
Power failure	Open collector logic signal goes high 100-500 msec after main output. It goes low at least 6 msec before loss of regulation
Remote sense	Compensates for 0.5 V lead drop minimum, will operate without remote sense connected. Reverse connection protected

Environmental Specifications

Operating temperature	0° to 50°C ambient. Derate each output at 2.5% per degree from 50° to 70°C. -20°C start up
Storage temperature	-40°C to 85°C
Electromagnetic susceptibility	Designed to meet EN61000-4; -2, -3, -4, -5, -6, -8, -11 Level 3
Humidity	Operating; non-condensing 10% to 95% RH
Vibration	IEC68-2-6 to the levels of IEC721-3-2
MTBF demonstrated	>550,000 hours at full load and 25°C ambient conditions

Mating Connectors

(SK1) AC Input	Molex P/N: 09-50-8031 (connector), PINS: 08-52-0113
AC Ground	Molex: 01-90020001
(SK2) DC Outputs	Molex 19141-0058/0063/0083; Spade lug based on Cable Ampacity/AWG
(SK3) Control Signals	Molex 90142-0010 (USA), PINS: 90119-2110 or Amp: 87977-3, PINS: 87309-8

Connector Kit #70-841-020, includes all of the above

1. Specifications subject to change without notice.
2. All dimensions in inches (mm), tolerance is \pm 0.02”.
3. Specifications are for convection rating at factory settings at 115 Vac input 25°C unless otherwise stated.
4. Mounting holes MH1 and MH2 should be grounded for EMI purposes.
5. Mounting hole MH1 is safety ground connection.
6. This power supply requires mounting on metal standoffs 0.20” (5 m) in height.
7. Warranty: 2 year
8. Weight: 0.75 lb/0.34 kg



Phone: (800) 377-4384
 Email: tech@solahd.com
 www.solahd.com

To comply with the published safety standards, the following must be observed when using this power supply:

- Maximum ambient temperature for GLS255-C must not exceed 50°C. Maximum ambient temperature for GLS253-C must not exceed 50°C at 250 W, 21 A or 70°C at 125 W, 10.5 A.
 - When installing the power supply in the end-use equipment, special attention is required to ensure safety compliance with the following safety standards: UL60950-1, EN60950-1, IEC60950-1, and CSA22.2 No. 60950-1-03; including the requirements for creepage distances, clearances, and distance through insulation between primary wiring and earth or secondary (SELV) wiring.
 - The power supply's rated input voltage is automatically selected. Please refer to the specification sheet for the input voltage range.
 - The maximum output power of the supply must not exceed the rating indicated in the specification sheet.
 - This unit contains a secondary output exceeding 240 VA. When installing the unit into the end system, make sure the secondary output and the appropriate wire cannot be touched.
 - The earth ground wire must be connected only to the point marked with the earth ground symbol (on the unit).
 - The disconnection from the line must be in the end system.
 - Hazardous voltages exist in the primary circuits. Disconnect the power supply before servicing.
 - When operating with a dc input voltage range, the unit input must be protected by a dc rated fuse in the end-use installation system.
 - The internal fuse should only be replaced with a F6.3AH, 250 V ac, type 21606.3 manufactured by Littelfuse, type 50CF063H manufactured by Triad, or type S501 manufactured by Cooper.
- NOTE:** Components, such as capacitors, may be positioned in front of the internal fuse. The unit must be protected by a fuse in the end system.
- This equipment is considered Class I according to protection against electric shock.
 - This power supply is marked following the provisions of the Low Voltage Directive, 2006/95/EC.
 - For technical assistance, contact SolaHD Technical Support at (800) 377-4384 or send an e-mail to tech@solahd.com. Please visit our Web site at www.solahd.com for additional product information and specification sheets.

Mechanical Outline

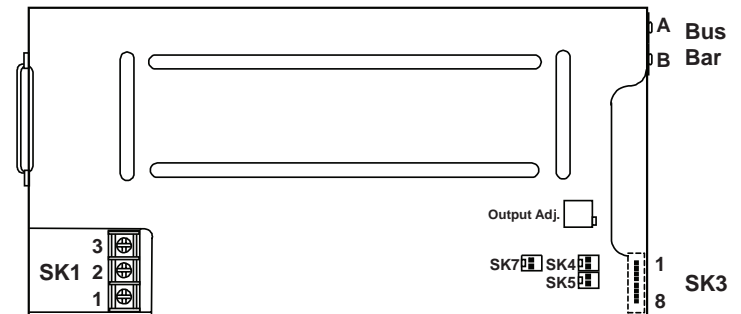

Connector PIN Designation

Input Connector	PIN	GLS253-C	GLS255-C
SK1	1	Neutral	
	2	Line	
	3	Earth GND	
Output Connector	PIN	GLS253-C	GLS255-C
Bus Bar	A	+6 V to +12 V	+24 V to +48 V
	B	Common	
SK3	1	+Sense	
	2	-Sense	
	3	Inhibit (normally open)	
	4	Inhibit (normally closed)	
	5	Common	
	6	C. Share	
	7	P OK	
	8	Dc OK	
SK4	1	Fan (+)	
	2	Fan (-)	
SK5	1	+5 V (aux)	
	2	Common	
SK7	1	Fan (+)	
	2	Fan (-)	

Output Ratings

Model	Output Voltage (V)	30 CFM Forced Air Cooling (unit not convection rated)	
		Max. Output Current (A)	Max. Output Power (W)
GLS253-C	+6 to +12	21.0	250 with cover
GLS255-C	+24 to +48	10.4	

Mechanical Dimensions

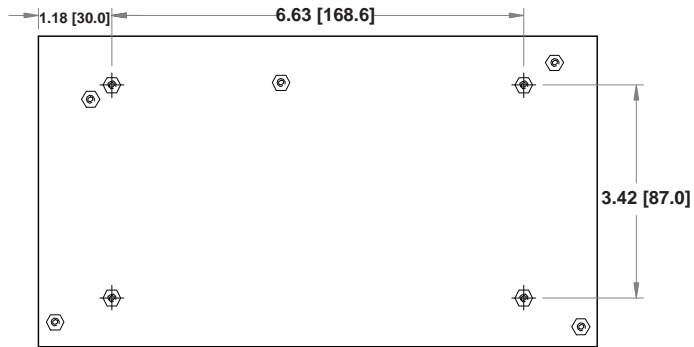

Bottom View

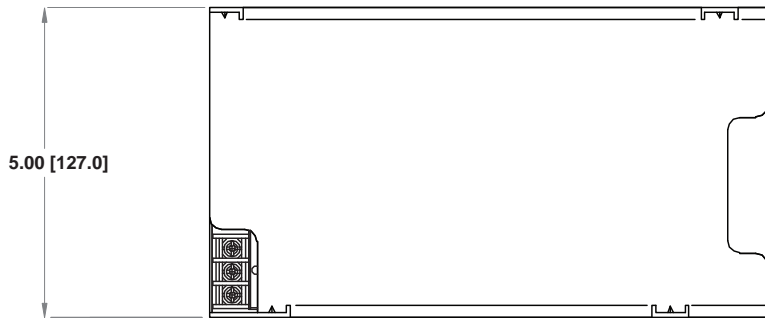

Top View

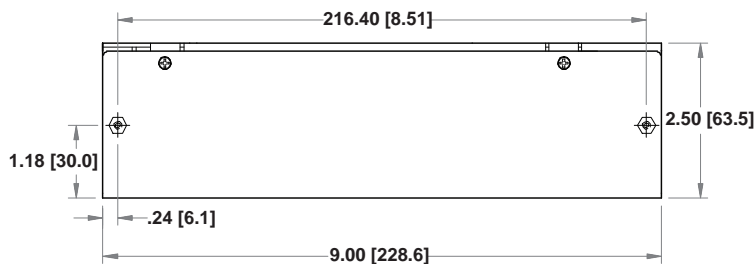

Side View

All dimension are in inches [mm]
Screw Size: #6-32

Typical Ventilation Setup

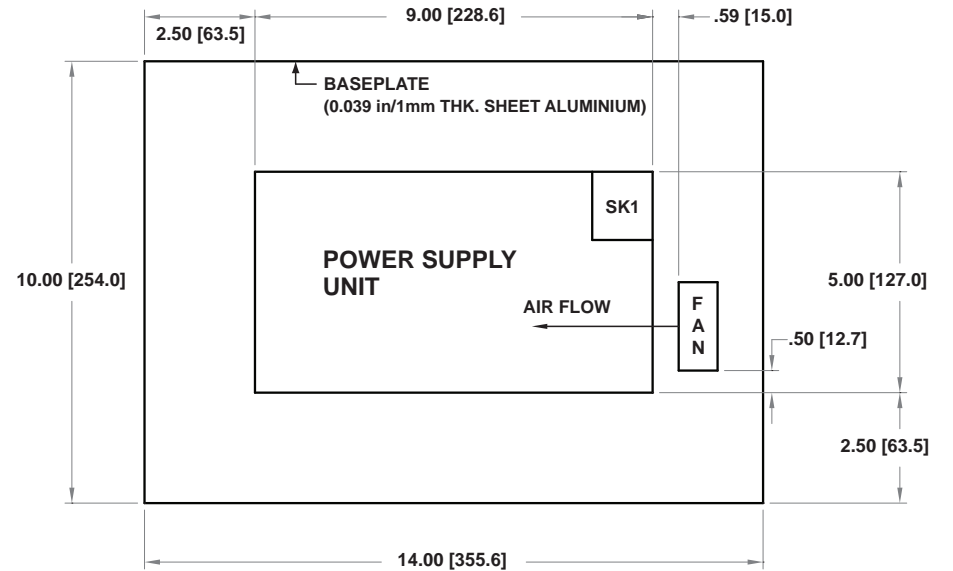

Fan Used: Minebea 2410ML-04W-B60, 12 V dc, 0.40 A
Dc Input for Fan Testing: 12 V dc
NOTE: Dimensions and fan used are for reference only

Output	
Maximum power	With cover: 250 W with 30 CFM forced air, (-C) (-CF) (-CEF)
Adjustment range	2:1 wide ratio
Supervisory output	5 V @ 100 mA regulated, 12 V @ 500 mA
Hold-up time	20 ms @ 250 W load, 115 Vac nominal line
Overload protection	Short circuit protection on all outputs. Case overload protected @ 10-145% above peak rating
Overvoltage protection	5 V output: 5.7 to 6.7 Vdc; Other models 10% to 25% above nominal output
Minimum load	1st output: 0.63 A - GLS253-C; 0.32 A -GLS255-C
Logic Control	
Power failure	TTL logic signal goes high 50-150 msec after 5 V output. It goes low at least 4 msec before loss of regulation
Remote on/off	Requires an external contact (N.O. or N.C.) to inhibit outputs
DC-OK	TTL logic goes high 50-150 msec after the output. It goes low when there is loss of regulation
Remote sense	Compensates for 0.5 V lead drop minimum, will operate without remote sense connected. Reverse connection protected

Environmental Specifications

Operating temperature	0° to 50°C ambient. Derate each output at 2.5% per degree from 50° to 70°C
Storage temperature	-40°C to 85°C
Temperature coefficient	±0.4% per °C
Electromagnetic susceptibility	Designed to meet IEC 801, -2, -3, -4, -5, -6, Level 3
Humidity	Operating; non-condensing 5% to 95%
Vibration	Three orthogonal axes, sweep at 1 oct/min, 5 min. dwell at four major resonances 0.7 G peak 5Hz to 500Hz, operational
MTBF demonstrated	>550,000 hours at full load and 25°C ambient conditions

Mating Connectors

SK3	Molex 22-01-1084 PINS: 08-70-0057
SK4	Molex 22-01-3027 PINS: 08-50-0114
SK5	Molex 22-01-3027 PINS: 08-50-0114
SK7	Molex 22-01-3027 PINS: 08-50-0114

Connector Kit #70-841-005, includes all of the above

1. Specifications subject to change without notice.
2. All dimensions in inches (mm), tolerance is ±0.02".
3. Specifications are at factory settings unless otherwise stated.
4. To enable normally closed remote inhibit, cut jumper J1.
5. Mounting maximum insertion depth is .12".
6. Warranty: 2 year
7. Weight: 2.6 lbs/1.19 kg



Phone: (800) 377-4384
Email: tech@solahd.com
www.solahd.com

SOLAHD GLS352-C, GLS353-C Installation & Operating Instructions

Installation & Safety

To comply with the published safety standards, the following must be observed when using this power supply:

1. Maximum ambient temperature for the power supply must not exceed 50°C.
2. When installing the power supply in the end-use equipment, special attention is required to ensure safety compliance with the following safety standards: UL60950-1, EN60950-1, IEC60950-1, and CSA22.2 No. 60950-1-03; including the requirements for creepage distances, clearances, and distance through insulation between primary wiring and earth or secondary (SELV) wiring.
3. The power supply's rated input voltage is automatically selected. Please refer to the specification sheet for the input voltage range.
4. The maximum output power of the supply must not exceed the rating indicated in the specification sheet.
5. This unit contains a secondary output exceeding 240 VA. When installing the unit into the end system, make sure the secondary output and the appropriate wire cannot be touched.
6. Hazardous voltages exist in the primary circuits. Disconnect the power supply before servicing.
7. The internal fuse should only be replaced with a F10AH, 250 V ac, type SP0001.1014 manufactured by Schurter AG or type 216010 manufactured by Littelfuse.
8. This power supply is **CE** marked following the provisions of the Low Voltage Directive, 2006/95/EC.

For technical assistance, contact SolaHD Technical Support at (800) 377-4384 or send an e-mail to tech@solahd.com. Please visit our Web site at www.solahd.com for additional product information and specification sheets.

Output Ratings

Model	Output Voltage (V)	30 CFM Forced Air Cooling (unit not convection rated)	
		Max. Output Current (A)	Max. Output Power (W)
GLS352-C	5 (+3 to +6)	70.0	350 with cover
GLS353-C	12 (+6 to +12)	29.2	

Mechanical Outline

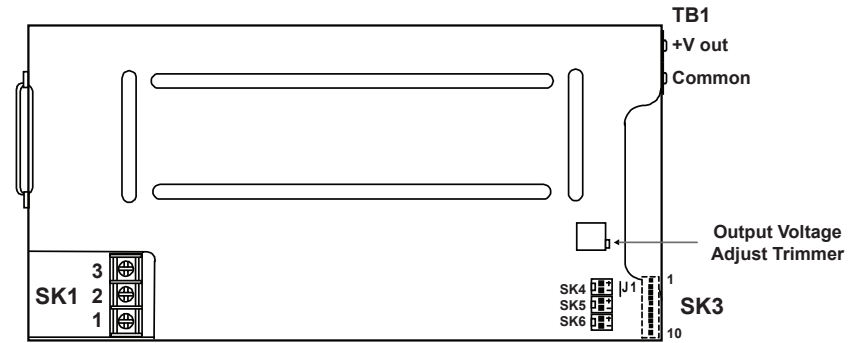

Connector PIN Designation

Input Connector	PIN	GLS352-C	GLS353-C
SK1	1	Neutral	
	2	Line	
	3	Earth GND	
Output Connector	PIN	GLS352-C	GLS353-C
TB1	+	V1 positive	
	-	V1 common	
SK3	1	No connection	
	2	No connection	
	3	+Sense	
	4	-Sense	
	5	P OK	
	6	C. Share	
	7	Dc OK	
	8	Inhibit (normally open)	
	9	Inhibit (normally closed)	
	10	Common	
SK4	1	+5 V (aux)	
	2	Common	
SK5	1	+Fan 1 (+12 V)	
	2	Common	
SK6	1	+Fan 2 (+12 V)	
	2	Common	

SOLAHD GLS352-C, GLS353-C Installation & Operating Instructions

Mechanical Dimensions

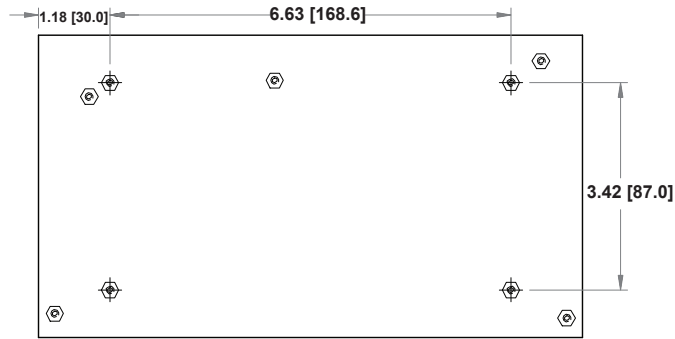

Bottom View

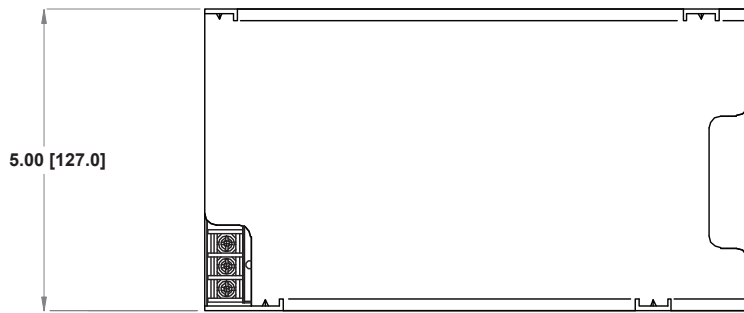

Top View

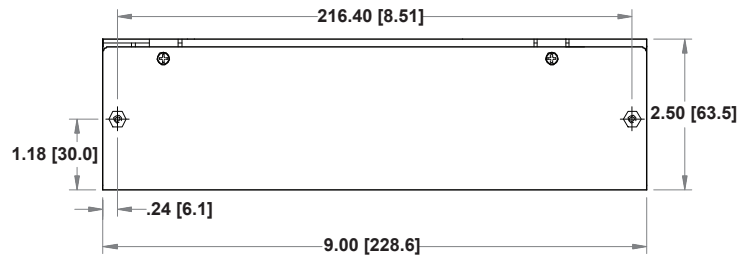

Side View

All dimension are in inches [mm]
Screw Size: #6-32

Typical Ventilation Setup

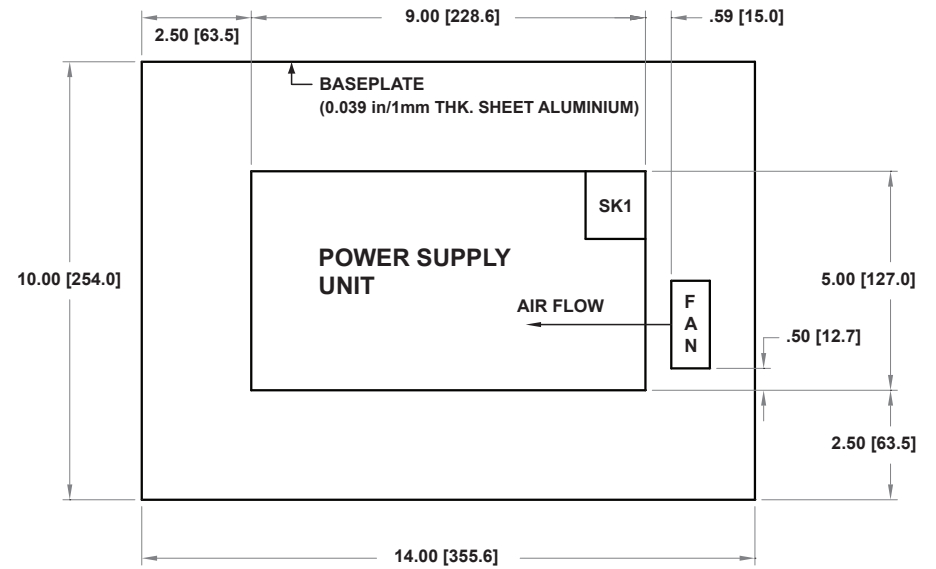

Fan Used: Minebea 2410ML-04W-B60, 12 V dc, 0.40 A or
Cheng Home CHA6012EB, 12 V dc, 0.28 A
Dc Input for Fan Testing: 12 V dc

NOTE: Dimensions and fan used are for reference only



leakage current

Output	
Maximum power	With cover: 350 W with 30 CFM forced air, (-C) (-CF) (-CEF)
Adjustment range	2:1 wide ratio
Supervisory output	5 V @ 500 mA regulated, 12 @ 150 mA x2
Hold-up time	20 ms @ 350W load, 115 Vac nominal line at factory voltage settings
Overload protection	Short circuit protection on all outputs. Case overload protected @ 110-145% above peak rating
Overvoltage protection	5 V output: 5.7 to 6.7 Vdc; Other models 10% to 25% above nominal output
Logic Control	
Power failure	TTL logic signal goes high 50-150 msec after the output is in regulation. It goes low at least 4 msec before loss of regulation
Remote on/off	Requires an external contact (N.O. or N.C.) to inhibit outputs
DC-OK	TTL logic goes high 50-150 msec after the output is in regulation. It goes low when there is loss of regulation
Remote sense	Compensates for 0.5 V lead drop minimum, will operate without remote sense connected. Reverse connection protected

Environmental Specifications

Operating temperature	0° to 50°C ambient. Derate each output 2.5% per degree from 50° to 70°C
Storage temperature	-40°C to 85°C
Temperature coefficient	±0.04% per °C
Electromagnetic susceptibility	Designed to meet IEC 801, -2, -3, -4, -5, -6, Level 3
Humidity	Operating; non-condensing 5% to 95%
Vibration	Three orthogonal axes, sweep at 1 oct/min, 5 min. dwell at four major resonances 0.7 G peak 5Hz to 500Hz, operational
MTBF demonstrated	>550,000 hours at full load and 25°C ambient conditions

Mating Connectors

SK3	Molex 22-01-1104 PINS: 08-70-0057
SK4	Molex 22-01-3027 PINS: 08-50-0114
SK5	Molex 22-01-3027 PINS: 08-50-0114
SK6	Molex 22-01-3027 PINS: 08-50-0114

Connector Kit #70-841-011, includes all of the above

1. Specifications subject to change without notice.
2. All dimensions in inches (mm), tolerance is ±0.02".
3. Specifications are at factory settings unless otherwise stated.
4. To enable normally closed Remote inhibit, cut jumper J1.
5. Mounting (6-32) maximum insertion depth is .12".
6. Warranty: 2 years
7. Weight: 3.6 lbs/1.64 kg



Phone: (800) 377-4384
Email: tech@solahd.com
www.solahd.com

SOLAHD GLS354-C, GLS355-C, GLS355-CEF Installation & Operating Instructions

Installation & Safety

To comply with the published safety standards, the following must be observed when using this power supply:

1. Maximum ambient temperature for the power supply must not exceed 50°C.
2. When installing the power supply in the end-use equipment, special attention is required to ensure safety compliance with the following safety standards: UL60950-1, EN60950-1, IEC60950-1, and CSA22.2 No. 60950-1-03; including the requirements for creepage distances, clearances, and distance through insulation between primary wiring and earth or secondary (SELV) wiring.
3. The power supply's rated input voltage is automatically selected. Please refer to the specification sheet for the input voltage range.
4. The maximum output power of the supply must not exceed the rating indicated in the specification sheet.
5. This unit contains a secondary output exceeding 240 VA. When installing the unit into the end system, make sure the secondary output and the appropriate wire cannot be touched.
6. Hazardous voltages exist in the primary circuits. Disconnect the power supply before servicing.
7. The internal fuse should only be replaced with a F10AH, 250 V ac, type SP0001.1014 manufactured by Schurter AG or type 216010 manufactured by Littelfuse.
8. This power supply is  marked following the provisions of the Low Voltage Directive, 2006/95/EC.

For technical assistance, contact SolaHD Technical Support at (800) 377-4384 or send an e-mail to tech@solahd.com. Please visit our Web site at www.solahd.com for additional product information and specification sheets.

Output Ratings

Model	Output Voltage (V)	30 CFM Forced Air Cooling (unit not convection rated)	
		Max. Output Current (A)	Max. Output Power (W)
GLS354-C	15 (+12 to +24)	23.4	350 with cover
GLS355-C (-CEF)	24 (+24 to +48)	14.6	

Mechanical Outline

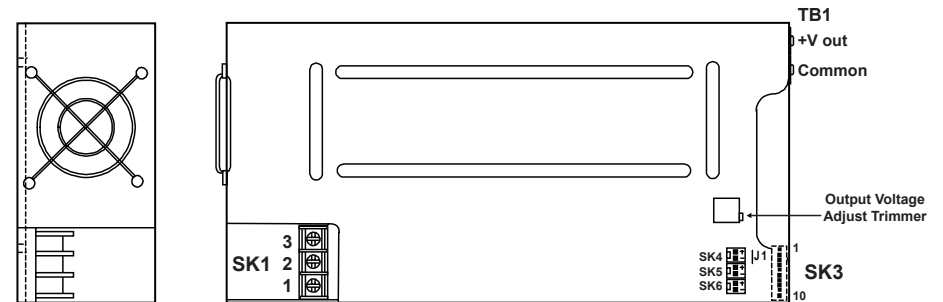

Connector PIN Designation

Input Connector	PIN	Designation
SK1	1	Neutral
	2	Line
	3	Earth GND
Output Connector	PIN	Designation
TB1	+	V1 positive
	-	V1 common
SK3	1	No connection
	2	No connection
	3	+Sense
	4	-Sense
	5	P OK
	6	C. Share
	7	Dc OK
	8	Inhibit (normally open)
	9	Inhibit (normally closed)
	10	Common
SK4	1	+5 V (aux)
	2	Common
SK5	1	+Fan 1 (+12 V)
	2	Common
SK6	1	+Fan 2 (+12 V)
	2	Common

SOLAHD GLS354-C, GLS355-C, GLS355-CEF Installation & Operating Instructions

Mechanical Dimensions

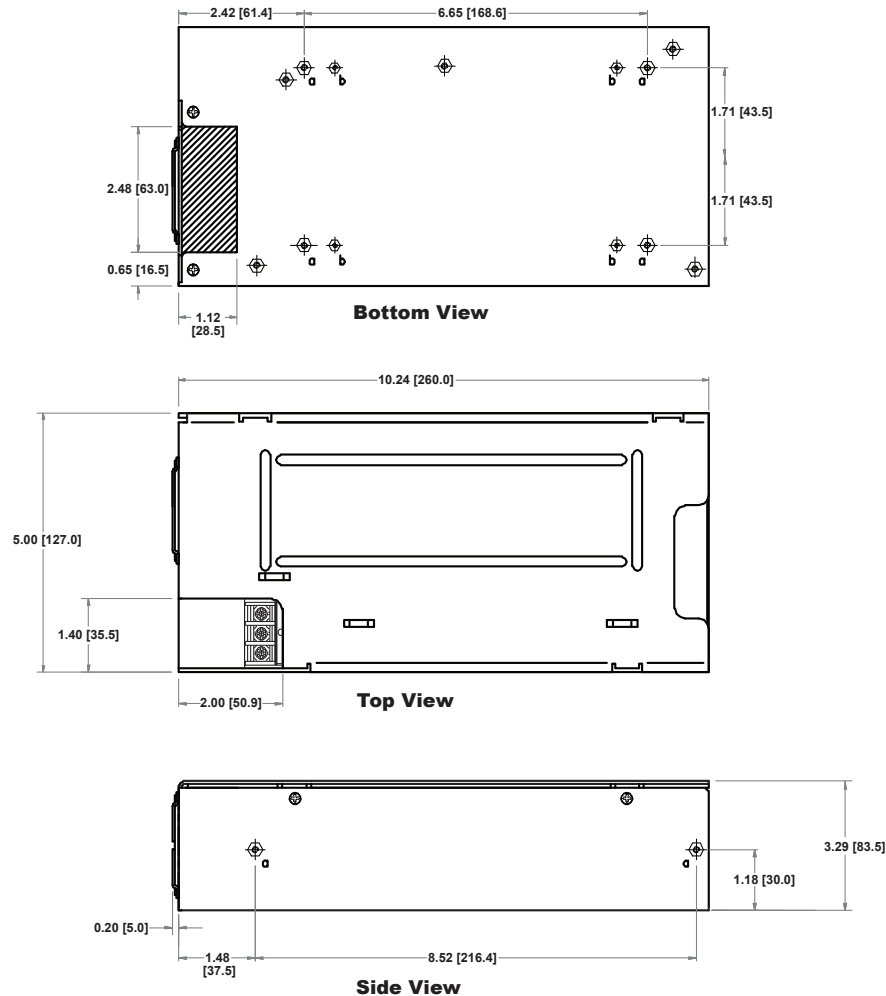

All dimensions are in inches [mm]
 Screw Size: a = #6-32 (U.S.); b = M3 (international)

Typical Ventilation Setup

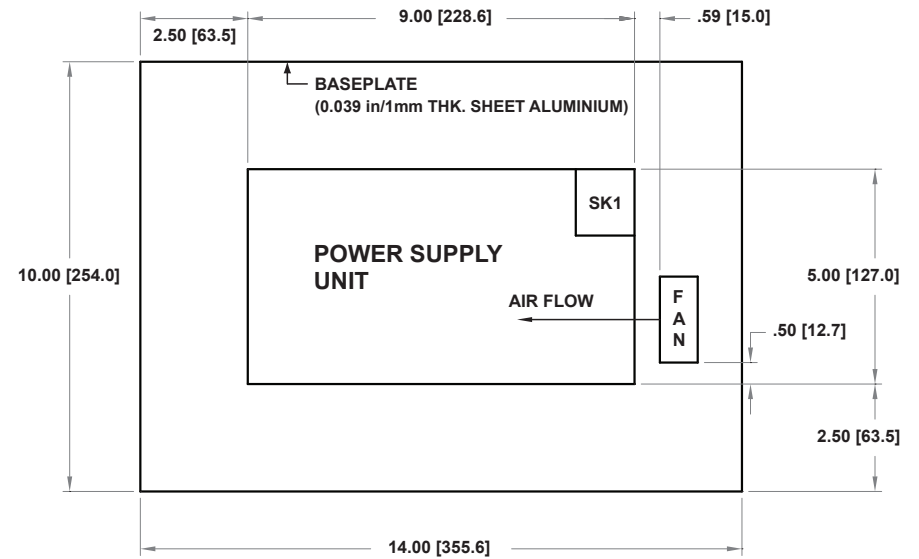

Fan Used: Minebea 2410ML-04W-B60, 12 V dc, 0.40 A or Cheng Home
 CHA6012EB, 12 V dc, 0.28 A
 Dc Input for Fan Testing: 12 V dc

NOTE: Dimensions and fan used are for reference only
 NOTE: Not applicable for -CEF models



leakage current

Output	
Maximum power	With cover: 350 W with 30 CFM forced air, (-C) (-CF) (-CEF)
Adjustment range	2:1 wide ratio
Supervisory output	5 V @ 500 mA regulated, 12 @ 150 mA x2
Hold-up time	20 ms @ 350W load, 115 Vac nominal line at factory voltage settings
Overload protection	Short circuit protection on all outputs. Case overload protected @ 110-145% above peak rating
Overvoltage protection	5 V output: 5.7 to 6.7 Vdc; Other models 10% to 25% above nominal output
Logic Control	
Power failure	TTL logic signal goes high 50-150 msec after the output is in regulation. It goes low at least 4 msec before loss of regulation
Remote on/off	Requires an external contact (N.O. or N.C.) to inhibit outputs
DC-OK	TTL logic goes high 50-150 msec after the output is in regulation. It goes low when there is loss of regulation
Remote sense	Compensates for 0.5 V lead drop minimum, will operate without remote sense connected. Reverse connection protected

Environmental Specifications

Operating temperature	0° to 50°C ambient. Derate each output 2.5% per degree from 50° to 70°C
Storage temperature	-40°C to 85°C
Temperature coefficient	±0.04% per °C
Electromagnetic susceptibility	Designed to meet IEC 801, -2, -3, -4, -5, -6, Level 3
Humidity	Operating; non-condensing 5% to 95%
Vibration	Three orthogonal axes, sweep at 1 oct/min, 5 min. dwell at four major resonances 0.7 G peak 5Hz to 500Hz, operational
MTBF demonstrated	>550,000 hours at full load and 25°C ambient conditions

Mating Connectors

SK3	Molex 22-01-1104 PINS: 08-70-0057
SK4	Molex 22-01-3027 PINS: 08-50-0114
SK5	Molex 22-01-3027 PINS: 08-50-0114
SK6	Molex 22-01-3027 PINS: 08-50-0114

Connector Kit #70-841-011, includes all of the above

1. Specifications subject to change without notice.
2. All dimensions in inches (mm), tolerance is ±0.02".
3. Specifications are at factory settings unless otherwise stated.
4. To enable normally closed Remote inhibit, cut jumper J1.
5. Mounting (6-32) maximum insertion depth is .12".
6. Warranty: 2 years
7. Weight: 3.6 lbs/1.64 kg



Phone: (800) 377-4384
Email: tech@solahd.com
www.solahd.com

SOLAHD GLS40 Series, GLS40-M Series Installation & Operating Instructions

Installation & Safety

To comply with the published safety standards, the following must be observed when using this power supply:

1. Maximum ambient temperature for the power supply must not exceed 50°C. The power supply has been evaluated for use in 70°C at half load.
2. When installing the power supply in the end-use equipment, special attention is required to ensure safety compliance with the following safety standards: UL60950-1, EN60950-1, IEC60950-1, and CSA22.2 No. 60950-1-03 for GLS42, GLS43, GLS44, and GLS45; UL60601-1, EN60601-1, IEC60601-1, and CSA22.2 No. 60601-1-M90 for GLS42-M, GLS43-M, GLS44-M, and GLS45-M. The safety requirements include creepage distances, clearances, and distance through insulation between primary wiring and earth or secondary (SELV) wiring.
3. The power supply's rated input voltage is automatically selected. Please refer to the specification sheet for the input voltage range.
4. The maximum output power of the supply must not exceed the rating indicated in the specification sheet.
5. The earth ground wire must be connected only to the point marked with the earth ground symbol (on the unit).
6. Hazardous voltages exist in the primary circuits. Disconnect the power supply before servicing.
7. When operating with a dc input voltage range, the unit input must be protected by a dc rated fuse in the end-use installation system.
8. The internal fuse should only be replaced with a 2.5 A, 250 V ac, type SP0001.1008 manufactured by Schurter AG or type 21602.5 manufactured by Littelfuse.
9. GLS42-M, GLS43-M, GLS44-M, and GLS45-M have no patient applied part.
10. This equipment is considered Class I according to protection against electric shock.
11. This power supply is **CE** marked following the provisions of the Low Voltage Directive, 2006/95/EC.

For technical assistance, contact SolaHD Technical Support at (800) 377-4384 or send an e-mail to tech@solahd.com. Please visit our Web site at www.solahd.com for additional product information and specification sheets.

Mechanical Outline

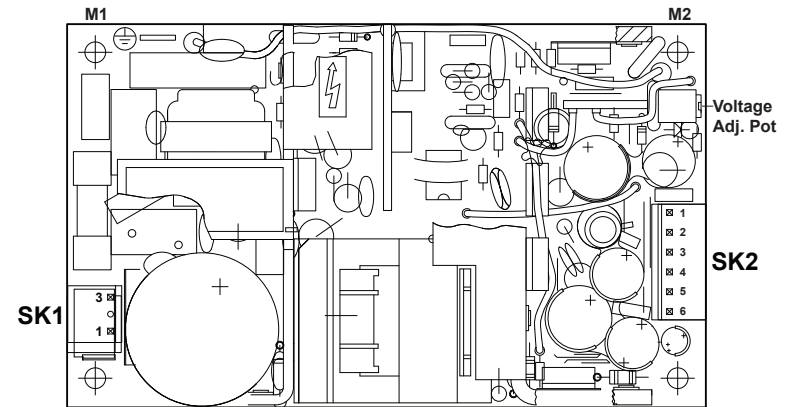

Connector PIN Designation

Input Connector	PIN	GLS42 (-M)	GLS43 (-M)	GLS44 (-M)	GLS45 (-M)
SK1	1	Line			
	3	Neutral			
Output Connector	PIN	GLS42 (-M)	GLS43 (-M)	GLS44 (-M)	GLS45 (-M)
SK2	1	+5 V	+12 V	+15 V	+24 V
	2				
	3				
	4	Common			
	5				
	6				
SK201	1	+Sense			
	2	-Sense			

NOTE: Mounting holes M1 and M2 should be grounded for EMI purposes. Mounting hole M1 is an earth ground connection.

Output Ratings

Model	Output Voltage (V)	Convection Cooling		30 CFM Forced Air Cooling	
		Max. Output Current (A)	Max. Output Power (W)	Max. Output Current (A)	Max. Output Power (W)
GLS42 (-M)	+5	8.0	40	11.0	55
GLS43 (-M)	+12	3.3		4.5	
GLS44 (-M)	+15	2.6		3.6	
GLS45 (-M)	+24	1.7		2.3	

SOLAHD GLS40 Series, GLS40-M Series Installation & Operating Instructions

Mechanical Dimensions

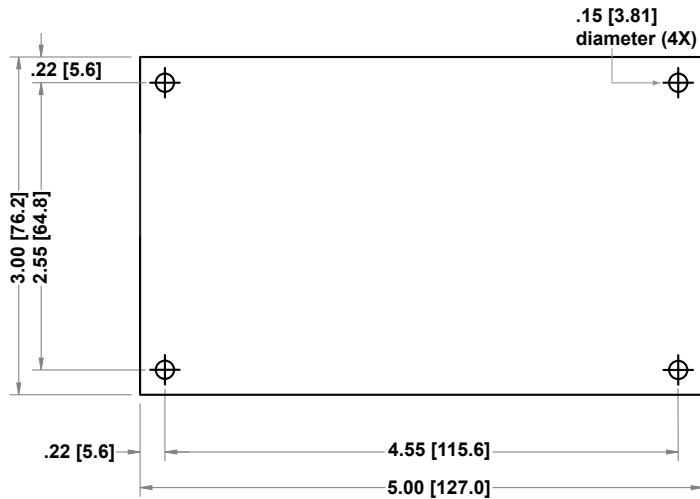

Bottom View

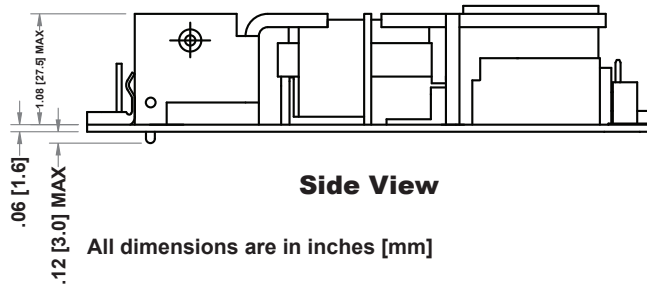

Side View

All dimensions are in inches [mm]

Typical Ventilation Setup

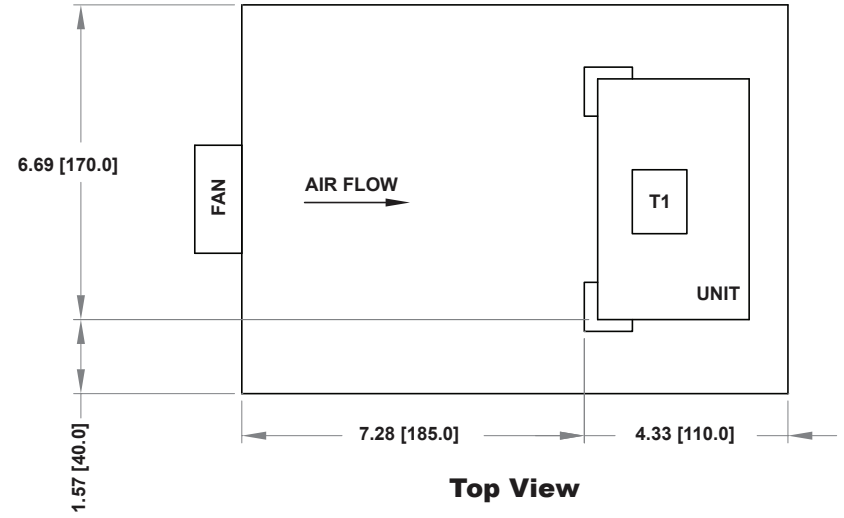

Top View

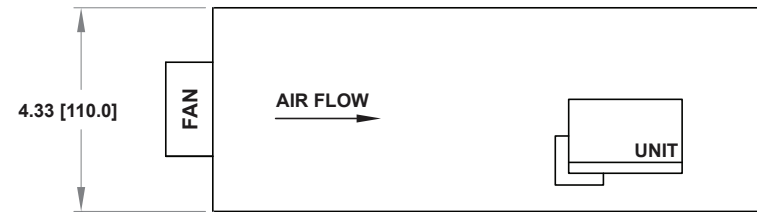

Side View

Fan: MINEBEA 3110NL-04W-B30

Fan Input: 12 V dc

NOTE: Dimensions and fan used are for reference only



EMI filter	EN55022 Class B conducted; VDE 0878 PT3 Class B conducted
Safety ground leakage current	<0.5 mA @ 50/60 Hz, 264 Vac input; GLS40-M: <75µA @ 50/60 Hz, 264 Vac input
Output	
Maximum power	40 W convection; 55 W with 30 CFM forced air
Adjustment range	-5, +10% minimum
Hold-up time	20 ms @ 40 W load, 115 Vac nominal line
Overload protection	Short circuit protection on all outputs Case overload protected @ 110-145% above peak rating
Overvoltage protection	5 V output; 5.7 to 6.7 Vdc. Other outputs 10 to 25% above nominal output
Remote sense	Compensates for 0.5 V lead drop min. Will operate without remote sense connected. Reverse connection protected.

Environmental Specifications

Operating temperature	0° to 50°C ambient. Derate each output 2.5% per degree from 50° to 70°C. -20°C start up.
Storage temperature	-40°C to 85°C
Temperature coefficient	±0.4% per °C
Electromagnetic susceptibility	Designed to meet IEC 801, -2, -3, -4, -5, -6, Level 3
Humidity	Operating; non-condensing 5% to 95% RH
Vibration	Three orthogonal axes, sweep at 1 oct/min, 5 min. dwell at four major resonances 0.75 G peak 5 Hz to 500 Hz, operational

Mating Connectors

AC Input	Molex 09-50-8031 (USA) Not required for (-T) option; 09-91-0300 (UK) PINS: 08-52-0113
DC Outputs	Molex 09-50-8061 (USA) Not required for (-T) option; 09-91-0600 (UK) PINS: 08-52-0113
Remote Sense	Molex 22-01-2025; PINS 08-52-0123

Connector Kit #70-841-006, includes all of the above

- Specifications subject to change without notice.
- All dimensions in inches (mm), tolerance is ±0.02" (±0.5mm).
- Mounting holes M1 and M2 should be grounded for EMI purposes.
- Mounting hole M1 is safety ground connection.
- Specifications are for convection rating at factory settings at 115 Vac input, 25°C unless otherwise stated.
- Warranty: 2 year
- Weight: 0.5 lb/0.23 kg

Power Derating Curve

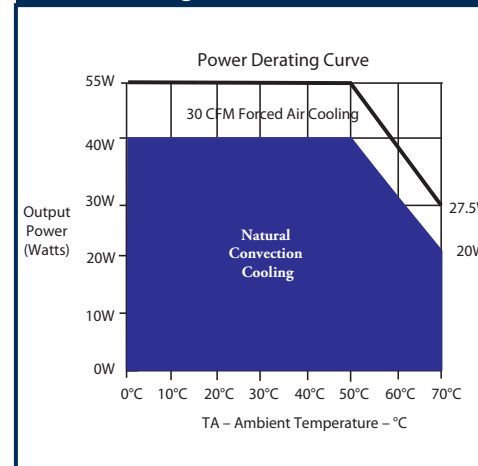

SOLAHD GLS503-CF, GLS503-M-CF Installation & Operating Instructions

Installation & Safety

To comply with the published safety standards, the following must be observed when using this power supply:

1. Maximum ambient temperature for the power supply must not exceed 50°C. Derate each output 2.5% per degree from 50°C to 70°C ambient temperature.
2. When installing the power supply in the end-use equipment, special attention is required to ensure safety compliance with the following safety standards: UL60950-1, EN60950-1, IEC60950-1, and CSA22.2 No. 60950-1-03 for the GLS503-CF; UL60601-1, EN60601-1, IEC60601-1, and CSA22.2 No. 60601-1 for the GLS503-M-CF. The safety requirements include creepage distances, clearances, and distance through insulation between primary wiring and earth or secondary (SELV) wiring.
3. The ac-dc input connector is approved as a component of the power supply, however, it was not specifically evaluated to IEC60320.
4. This power supply is approved and certified for the rated voltage range of 100 V ac to 250 V ac and/or 120 V dc (minimum) to 300 V dc (maximum).
5. The maximum output power of the supply must not exceed the rating indicated in the specification sheet.
6. This power supply contains a +12 V output exceeding 240 VA. When installing the unit into the end system, make sure the outputs and the appropriate wire cannot not be touched.
7. The disconnection from the line must be in the end system.
8. Hazardous voltages exist in the primary circuits. Disconnect power supply before servicing.
9. The internal fuses (F1, F2) should only be replaced by a F10AH A, 250 V ac, type 216010 MXEP manufactured by Littelfuse or type 5HFP manufactured by Belfuse.
NOTE: The power supply has a fuse on the on the neutral line.
10. The earthing conductor in the end system should not be less than 8 awg (10 mm²) in a cross-sectional area.
11. GLS503-M-CF has no patient applied part.
12. The equipment is considered Class I according to protection against electric shock.
13. This power supply is **CE** marked following the provisions of the Low Voltage Directive, 2006/95/EC.

For technical assistance, contact SolaHD Technical Support at (800) 377-4384 or send an e-mail to tech@solahd.com. Please visit our Web site at www.solahd.com for additional product information and specification sheets.

Mechanical Outline

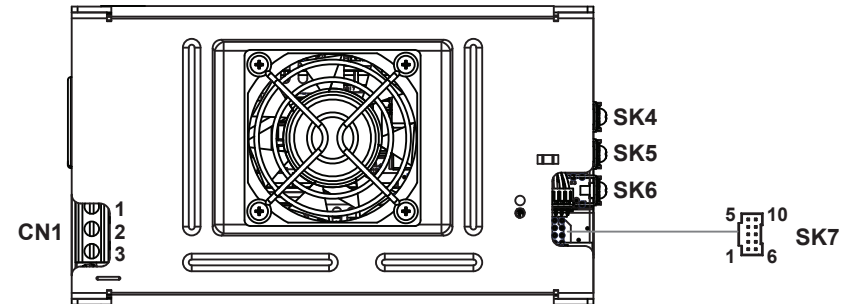

Connector PIN Designation

Input Terminal	PIN	Designation
CN1	1	Line
	2	Neutral
	3	Earth GND
Output Connector	PIN	Designation
SK4		OR-ing terminal
SK5		+12 V main
SK6		Common/Return
SK7 (Signal Output)	1	V1 SWP (Single Wire Parallel)
	2	-Remote sense
	3	+Remote sense
	4	+5 V standby
	5	Standby return
	6	+12 V (fan out)
	7	Common
	8	Remote inhibit
	9	Dc power good
	10	Power fail

Note: For information on the I2C Header (CN403) and Fan Header (SK8), please contact Technical Support.

Output Ratings

Output Voltage (V)	Convection Cooling		30 CFM Forced Air Cooling	
	Max. Output Current (A)	Max. Output Power (W)	Max. Output Current (A)	Max. Output Power (W)
+12	16.67	200	41.67	500 with cover fan
+5 standby	1.00		2.00	
+12 (fan out)	0.50		0.50	

SOLAHD GLS503-CF, GLS503-M-CF Installation & Operating Instructions

Mechanical Dimensions

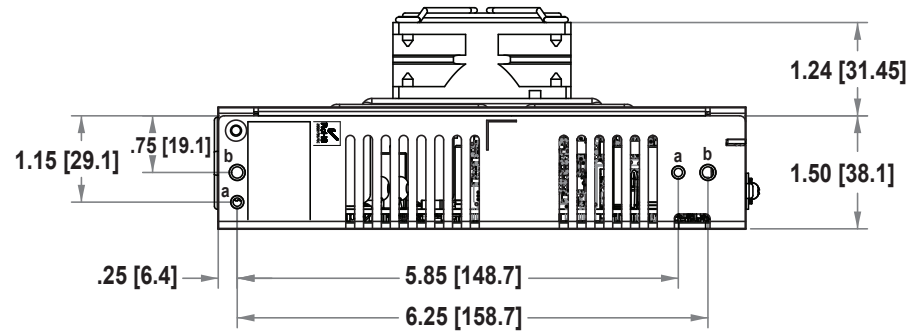

Side View

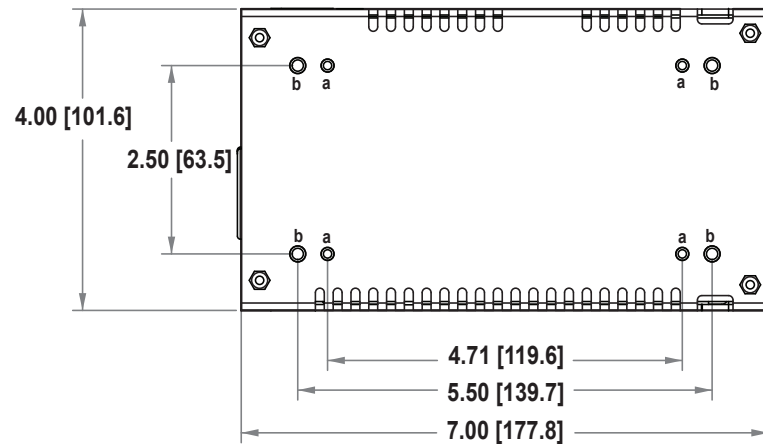

Bottom View

All dimensions are in inches [mm]

Screw Size: a = M3 (International); b = #6-32 (U.S.)



leakage current <0.5 mA @ 50/60 Hz, 204 Vac input <0.5 mA @ 50/60 Hz, 204 Vac input for GLS500-M)

Output	
Maximum power	200 W convection; 500 W with 30 CFM forced air
Adjustment range	±5%
Standby output	5 V @ 1 A convection, 2 A forced air, regulated, ±5%
Fan output	12 V @ 1 A, -5%, +7%, 0.5 A for -CF version
Hold-up time	20 ms @ 500 W load, 115 Vac nominal line at factory voltage setting
Overload protection	Short circuit protection on all outputs Case overload protected @ 115-130% above peak rating
Overvoltage protection	20-35% above nominal output
Logic Control	
Power failure	TTL logic signal goes high 100-500 msec after main output. It goes low at least 4 msec before loss of regulation.
Remote on/off	Requires an external contact closure to inhibit outputs
DC OK	TTL logic goes high after the output is in regulation. It goes low when there is loss of regulation.
Remote sense	Compensates for 0.5 V lead drop min. Will operate without remote sense connected. Reverse connection protected.

Environmental Specifications

Operating temperature	0° to 50°C ambient. Derate each output 2.5% per degree from 50° to 70°C
Storage temperature	-40°C to 85°C
Electromagnetic susceptibility	Designed to meet EN61000-4; -2, -3, -4, -5, -6, -8, -11 Level 3
Humidity	Operating; non-condensing 10% to 90% RH
Vibration	Three orthogonal axes, sweep at 1 oct/min, 5 min. dwell at four major resonances 2 G peak 8Hz to 500Hz, operational

Mating Connectors

SK4,5,6	Molex 19141-0058
SK7 Control Signal	Molex 90142-0010; PINS: 90119-2110 or Amp 87977-3; PINS: 87309-8
SK8	JST PHR-2; PINS: SPH-002T-PO.5S
CN403	JST PHDR-10VS; PINS: JST 5PHD-002T-PO.5-L/P or Landwin 2050 S1000; PINS: 2053T011P

Connector Kit #70-841-024, includes all of the above

1. Specifications subject to change without notice.
2. All dimensions in inches (mm), tolerance is ±0.02" (±0.5mm)
3. Specifications are at factory settings unless otherwise stated.
4. Mounting screw maximum insertion depth is .12".
5. Warranty: 2 years
6. Weight: 3.016 lbs/1.18 kg



Phone: (800) 377-4384
Email: tech@solahd.com
www.solahd.com

SOLAHD GLS505-CF, GLS505-M-CF Installation & Operating Instructions

Installation & Safety

To comply with the published safety standards, the following must be observed when using this power supply:

- Maximum ambient temperature for the power supply must not exceed 50°C. Derate each output 2.5% per degree from 50°C to 70°C ambient temperature.
- When installing the power supply in the end-use equipment, special attention is required to ensure safety compliance with the following safety standards: UL60950-1, EN60950-1, IEC60950-1, and CSA22.2 No. 60950-1-03 for the GLS505-CF; UL60601-1, EN60601-1, IEC60601-1, and CSA22.2 No. 60601-1 for the GLS505-M-CF. The safety requirements include creepage distances, clearances, and distance through insulation between primary wiring and earth or secondary (SELV) wiring.
- The ac-dc input connector is approved as a component of the power supply, however, it was not specifically evaluated to IEC60320.
- This power supply is approved and certified for the rated voltage range of 100 V ac to 250 V ac and/or 120 V dc (minimum) to 300 V dc (maximum).
- The maximum output power of the supply must not exceed the rating indicated in the specification sheet.
- This power supply contains a +24 V output exceeding 240 VA. When installing the unit into the end system, make sure the outputs and the appropriate wire cannot not be touched.
- The disconnection from the line must be in the end system.
- Hazardous voltages exist in the primary circuits. Disconnect power supply before servicing.
- The internal fuses (F1, F2) should only be replaced by a F10AH A, 250 V ac, type 216010 MXEP manufactured by Littelfuse or type 5HFP manufactured by Belfuse.
NOTE: The power supply has a fuse on the neutral line.
- The earthing conductor in the end system should not be less than 8 awg (10 mm²) in a cross-sectional area.
- GLS505-M-CF has no patient applied part.
- The equipment is considered Class I according to protection against electric shock.
- This power supply is CE marked following the provisions of the Low Voltage Directive, 2006/95/EC.

For technical assistance, contact SolaHD Technical Support at (800) 377-4384 or send an e-mail to tech@solahd.com. Please visit our Web site at www.solahd.com for additional product information and specification sheets.

Mechanical Outline

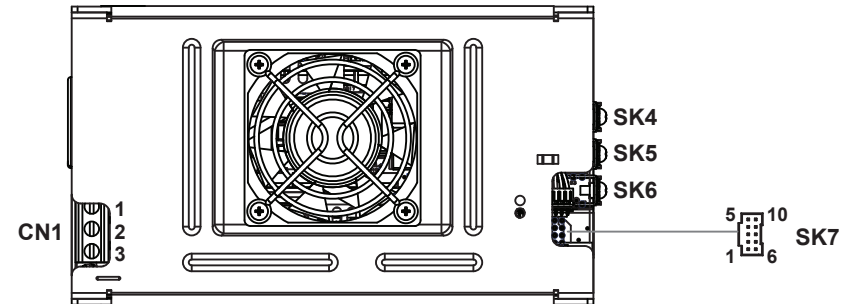

Connector PIN Designation

Input Terminal	PIN	Designation
CN1	1	Line
	2	Neutral
	3	Earth GND
Output Connector	PIN	Designation
SK4		OR-ing terminal
SK5		+24 V main
SK6		Common/Return
SK7 (Signal Output)	1	V1 SWP (Single Wire Parallel)
	2	-Remote sense
	3	+Remote sense
	4	+5 V standby
	5	Standby return
	6	+12 V (fan out)
	7	Common
	8	Remote inhibit
	9	Dc power good
	10	Power fail

Note: For information on the I2C Header (CN403) and Fan Header (SK8), please contact Technical Support.

Output Ratings

Output Voltage (V)	Convection Cooling		30 CFM Forced Air Cooling	
	Max. Output Current (A)	Max. Output Power (W)	Max. Output Current (A)	Max. Output Power (W)
+24	8.34	200	20.84	500 with cover fan
+5 standby	1.00		2.00	
+12 (fan out)	0.50		0.50	

SOLAHD GLS505-CF, GLS505-M-CF Installation & Operating Instructions

Mechanical Dimensions

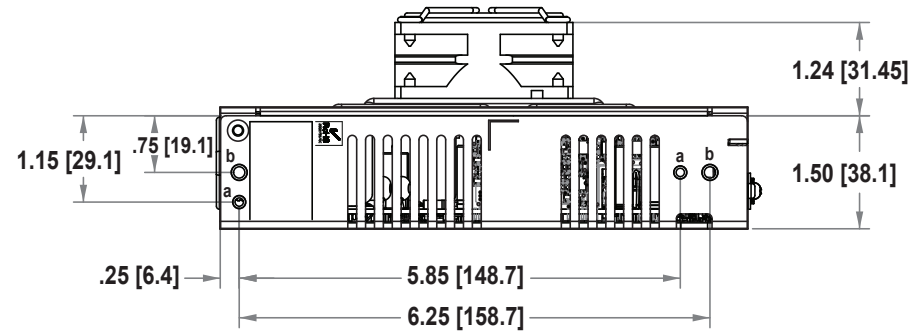

Side View

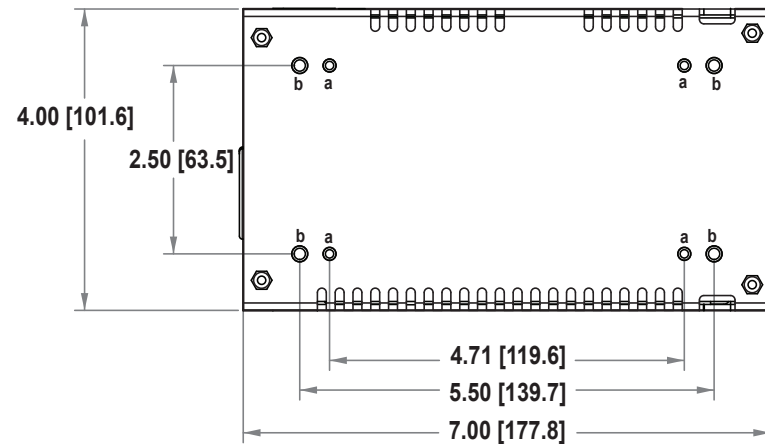

Bottom View

All dimensions are in inches [mm]

Screw Size: a = M3 (International); b = #6-32 (U.S.)



leakage current <0.5 mA @ 50/60 Hz, 204 Vac input <0.5 mA @ 50/60 Hz, 204 Vac input for GLS500-M)

Output	
Maximum power	200 W convection; 500 W with 30 CFM forced air
Adjustment range	±5%
Standby output	5 V @ 1 A convection, 2 A forced air, regulated, ±5%
Fan output	12 V @ 1 A, -5%, +7%, 0.5 A for -CF version
Hold-up time	20 ms @ 500 W load, 115 Vac nominal line at factory voltage setting
Overload protection	Short circuit protection on all outputs Case overload protected @ 115-130% above peak rating
Overvoltage protection	20-35% above nominal output
Logic Control	
Power failure	TTL logic signal goes high 100-500 msec after main output. It goes low at least 4 msec before loss of regulation.
Remote on/off	Requires an external contact closure to inhibit outputs
DC OK	TTL logic goes high after the output is in regulation. It goes low when there is loss of regulation.
Remote sense	Compensates for 0.5 V lead drop min. Will operate without remote sense connected. Reverse connection protected.

Environmental Specifications

Operating temperature	0° to 50°C ambient. Derate each output 2.5% per degree from 50° to 70°C
Storage temperature	-40°C to 85°C
Electromagnetic susceptibility	Designed to meet EN61000-4; -2, -3, -4, -5, -6, -8, -11 Level 3
Humidity	Operating; non-condensing 10% to 90% RH
Vibration	Three orthogonal axes, sweep at 1 oct/min, 5 min. dwell at four major resonances 2 G peak 8Hz to 500Hz, operational

Mating Connectors

SK4,5,6	Molex 19141-0058
SK7 Control Signal	Molex 90142-0010; PINS: 90119-2110 or Amp 87977-3; PINS: 87309-8
SK8	JST PHR-2; PINS: SPH-002T-PO.5S
CN403	JST PHDR-10VS; PINS: JST 5PHD-002T-PO.5-L/P or Landwin 2050 S1000; PINS: 2053T011P

Connector Kit #70-841-024, includes all of the above

1. Specifications subject to change without notice.
2. All dimensions in inches (mm), tolerance is ±0.02" (±0.5mm)
3. Specifications are at factory settings unless otherwise stated.
4. Mounting screw maximum insertion depth is .12".
5. Warranty: 2 years
6. Weight: 3.016 lbs/1.18 kg



Phone: (800) 377-4384
Email: tech@solahd.com
www.solahd.com

SOLAHD GLS508-CF, GLS508-M-CF Installation & Operating Instructions

Installation & Safety

To comply with the published safety standards, the following must be observed when using this power supply:

- Maximum ambient temperature for the power supply must not exceed 50°C. Derate each output 2.5% per degree from 50°C to 70°C ambient temperature.
- When installing the power supply in the end-use equipment, special attention is required to ensure safety compliance with the following safety standards: UL60950-1, EN60950-1, IEC60950-1, and CSA22.2 No. 60950-1-03 for the GLS508-CF; UL60601-1, EN60601-1, IEC60601-1, and CSA22.2 No. 60601-1 for the GLS508-M-CF. The safety requirements include creepage distances, clearances, and distance through insulation between primary wiring and earth or secondary (SELV) wiring.
- The ac-dc input connector is approved as a component of the power supply, however, it was not specifically evaluated to IEC60320.
- This power supply is approved and certified for the rated voltage range of 100 V ac to 250 V ac and/or 120 V dc (minimum) to 300 V dc (maximum).
- The maximum output power of the supply must not exceed the rating indicated in the specification sheet.
- This power supply contains a +48 V output exceeding 240 VA. When installing the unit into the end system, make sure the outputs and the appropriate wire cannot not be touched.
- The disconnection from the line must be in the end system.
- Hazardous voltages exist in the primary circuits. Disconnect power supply before servicing.
- The internal fuses (F1, F2) should only be replaced by a F10AH A, 250 V ac, type 216010 MXEP manufactured by Littelfuse or type 5HFP manufactured by Belfuse.
NOTE: The power supply has a fuse on the neutral line.
- The earthing conductor in the end system should not be less than 8 awg (10 mm²) in a cross-sectional area.
- GLS508-M-CF has no patient applied part.
- The equipment is considered Class I according to protection against electric shock.
- This power supply is **CE** marked following the provisions of the Low Voltage Directive, 2006/95/EC.

For technical assistance, contact SolaHD Technical Support at (800) 377-4384 or send an e-mail to tech@solahd.com. Please visit our Web site at www.solahd.com for additional product information and specification sheets.

Mechanical Outline

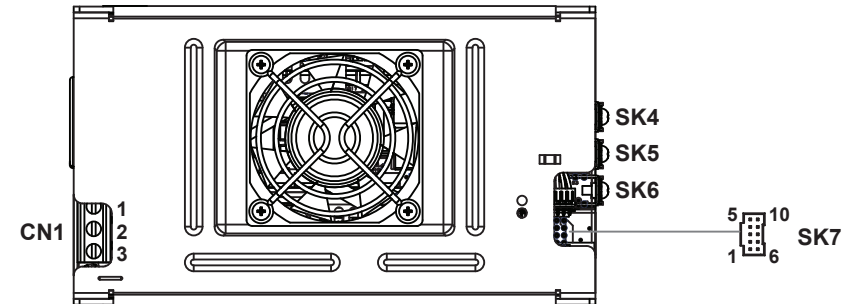

Connector PIN Designation

Input Terminal	PIN	Designation
CN1	1	Line
	2	Neutral
	3	Earth GND
Output Connector	PIN	Designation
SK4		OR-ing terminal
SK5		+48 V main
SK6		Common/Return
SK7 (Signal Output)	1	V1 SWP (Single Wire Parallel)
	2	-Remote sense
	3	+Remote sense
	4	+5 V standby
	5	Standby return
	6	+12 V (fan out)
	7	Common
	8	Remote inhibit
	9	Dc power good
	10	Power fail

Note: For information on the I2C Header (CN403) and Fan Header (SK8), please contact Technical Support.

Output Ratings

Output Voltage (V)	Convection Cooling		30 CFM Forced Air Cooling	
	Max. Output Current (A)	Max. Output Power (W)	Max. Output Current (A)	Max. Output Power (W)
+48	4.167	200	10.42	500 with cover fan
+5 standby	1.00		2.00	
+12 (fan out)	0.50		0.50	

SOLAHD GLS508-CF, GLS508-M-CF Installation & Operating Instructions

Mechanical Dimensions

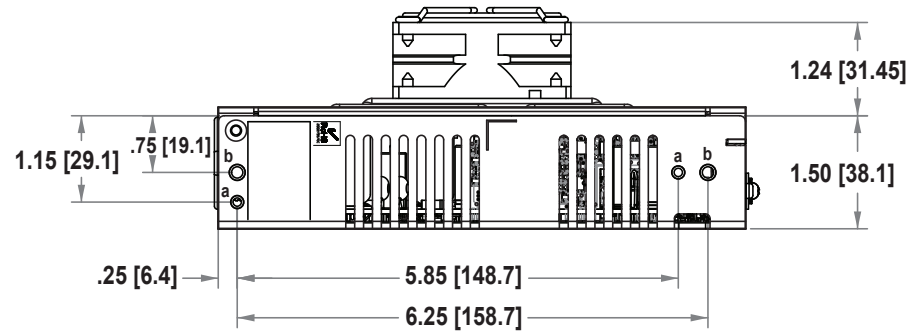

Side View

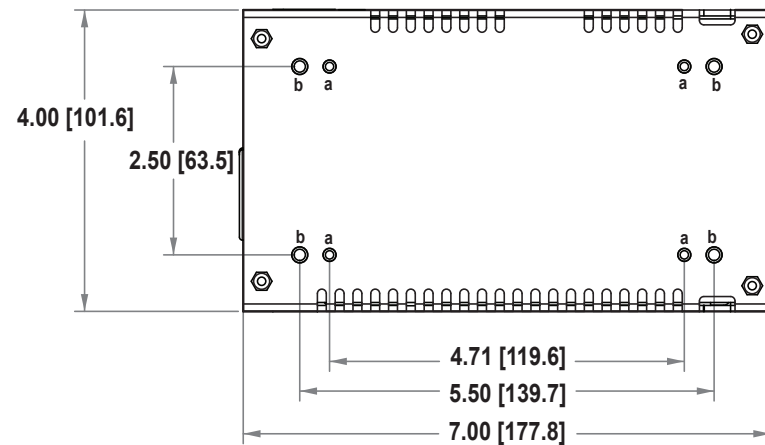

Bottom View

All dimensions are in inches [mm]

Screw Size: a = M3 (International); b = #6-32 (U.S.)



leakage current <0.5 mA @ 50/60 Hz, 204 Vac input <0.5 mA @ 50/60 Hz, 204 Vac input for GLS500-M)

Output	
Maximum power	200 W convection; 500 W with 30 CFM forced air
Adjustment range	±5%
Standby output	5 V @ 1 A convection, 2 A forced air, regulated, ±5%
Fan output	12 V @ 1 A, -5%, +7%, 0.5 A for -CF version
Hold-up time	20 ms @ 500 W load, 115 Vac nominal line at factory voltage setting
Overload protection	Short circuit protection on all outputs Case overload protected @ 115-130% above peak rating
Overvoltage protection	20-35% above nominal output
Logic Control	
Power failure	TTL logic signal goes high 100-500 msec after main output. It goes low at least 4 msec before loss of regulation.
Remote on/off	Requires an external contact closure to inhibit outputs
DC OK	TTL logic goes high after the output is in regulation. It goes low when there is loss of regulation.
Remote sense	Compensates for 0.5 V lead drop min. Will operate without remote sense connected. Reverse connection protected.

Environmental Specifications

Operating temperature	0° to 50°C ambient. Derate each output 2.5% per degree from 50° to 70°C
Storage temperature	-40°C to 85°C
Electromagnetic susceptibility	Designed to meet EN61000-4; -2, -3, -4, -5, -6, -8, -11 Level 3
Humidity	Operating; non-condensing 10% to 90% RH
Vibration	Three orthogonal axes, sweep at 1 oct/min, 5 min. dwell at four major resonances 2 G peak 8Hz to 500Hz, operational

Mating Connectors

SK4,5,6	Molex 19141-0058
SK7 Control Signal	Molex 90142-0010; PINS: 90119-2110 or Amp 87977-3; PINS: 87309-8
SK8	JST PHR-2; PINS: SPH-002T-PO.5S
CN403	JST PHDR-10VS; PINS: JST 5PHD-002T-PO.5-L/P or Landwin 2050 S1000; PINS: 2053T011P

Connector Kit #70-841-024, includes all of the above

1. Specifications subject to change without notice.
2. All dimensions in inches (mm), tolerance is ±0.02" (±0.5mm)
3. Specifications are at factory settings unless otherwise stated.
4. Mounting screw maximum insertion depth is .12".
5. Warranty: 2 years
6. Weight: 3.016 lbs/1.18 kg



Phone: (800) 377-4384
Email: tech@solahd.com
www.solahd.com

SOLAHD GLS50 Series, GLS50-M Series Installation & Operating Instructions

Installation & Safety

To comply with the published safety standards, the following must be observed when using this power supply:

1. Maximum ambient temperature for the power supply must not exceed 50°C. The power supply has been evaluated for use in 70°C at half load (27.5) for GLS52 only; (30 W) for GLS53, GLS54, GLS55, and GLS58 only.
2. When installing the power supply in the end-use equipment, special attention is required to ensure safety compliance with the following safety standards: UL60950-1, EN60950-1, IEC60950-1, and CSA22.2 No. 60950-1-03 for GLS52, GLS53, GLS54, GLS55, and GLS58; UL60601-1, EN60601-1, IEC60601-1, and CSA22.2 No. 60601-1-M90 for GLS52-M, GLS53-M, GLS54-M, GLS55-M, and GLS58-M. The safety requirements include creepage distances, clearances, and distance through insulation between primary wiring and earth or secondary (SELV) wiring.
3. This power supply is approved and certified for the rated voltage range of 100 V ac to 240 V ac.
4. The maximum output power of the supply must not exceed the rating indicated in the specification sheet.
5. The disconnection from the line must be in the end system.
6. The internal fuse should only be replaced with a T3.15AH, 250 V ac, type TE5/392 manufactured by Wickmann.
NOTE: The power supply has a fuse on the neutral line for GLS52-M, GLS53-M, GLS54-M, GLS55-M, and GLS58-M.
7. GLS52-M, GLS53-M, GLS54-M, GLS55-M, and GLS58-M have no patient applied part.
8. This equipment is considered Class I according to protection against electric shock.
9. This power supply is  marked following the provisions of the Low Voltage Directive, 2006/95/EC.

For technical assistance, contact SolaHD Technical Support at (800) 377-4384 or send an e-mail to tech@solahd.com. Please visit our Web site at www.solahd.com for additional product information and specification sheets.

Output Ratings

Model	Output Voltage (V)	Convection Cooling	
		Max. Output Current (A)	Max. Output Power (W)
GLS52 (-M)	+5	11.0	55
GLS53 (-M)	+12	5.0	60
GLS54 (-M)	+15	4.0	
GLS55 (-M)	+24	2.5	
GLS58 (-M)	+48	1.25	

Connector PIN Designation

Input Connector	PIN	GLS52 (-M)	GLS53 (-M)	GLS54 (-M)	GLS55 (-M)	GLS58 (-M)
SK1	1	Line				
	3	Neutral				
Output Connector	PIN	GLS52 (-M)	GLS53 (-M)	GLS54 (-M)	GLS55 (-M)	GLS58 (-M)
SK2	1	+5 V	+12 V	+15 V	+24 V	+48 V
	2	+5 V	+12 V	+15 V	+24 V	+48 V
	3	Common				
	4	Common				
	5	-Sense				
	6	+Sense				

SOLAHD GLS50 Series, GLS50-M Series Installation & Operating Instructions

Mechanical Outline & Dimensions

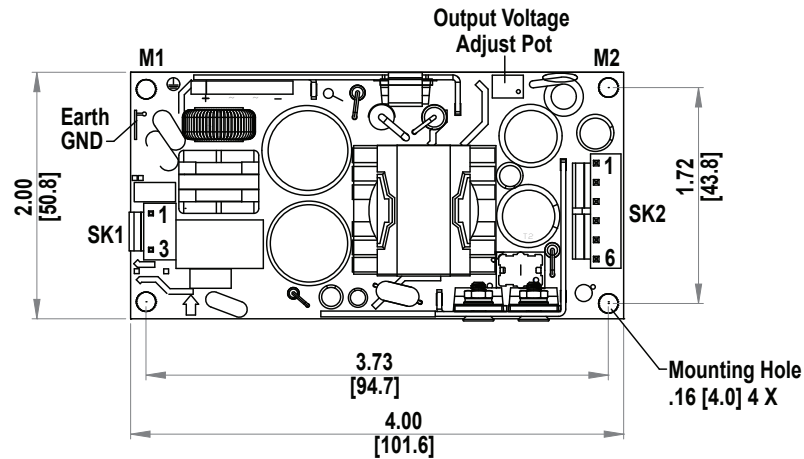

Top View

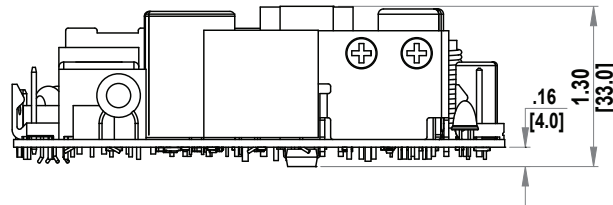

Side View

All dimensions are in inches [mm].

Maximum screw head diameter is .22" [5.6 mm].

Mounting holes M1 and M2 should be grounded for EMI purposes. Mounting hole M1 is an earth ground connection.

CAUTION! Do not accidentally connect the ac connector to the dc output.

EMI/RFI	EN55022 Class B conducted; VDE 0878 PT3 Class B conducted
Safety ground leakage current	<0.5 mA @ 50/60 Hz, 264 Vac input for class I; < 0.25 mA @ 50/60 Hz; 264 Vac input for class II GLS50-M: 275 uA @ 50/60 Hz; 264 Vac input
Output	
Maximum power	60 W convection; (GLS52, 55 W)
Adjustment range	±20% minimum
Hold-up time	10/20 ms 115/230 Vac input line
Overload protection	Short circuit protection on all outputs Case overload protected @ 110-160% of normal rating
Overvoltage protection	30-50% above nominal output
Remote sense	Compensates for 0.5 lead V lead drop max. Will operate without remote sense. Reverse connection protected.

Environmental Specifications

Operating temperature	0° to 50°C ambient. Derate each output 2.5% per degree from 50° to 70°C. -20°C start up.
Storage temperature	-40°C to 85°C
Electromagnetic susceptibility	Designed to meet EN61000-4; -2, -3, -4, -5, -6, -8, -11 Level 3
Humidity	Operating; non-condensing 10% to 95% RH
Vibration	IEC68-2-6 to the levels of IEC721-3-2
MTBF demonstrated	> 550,000 hours at full load and 25°C ambient conditions

Mating Connectors

AC Input	Molex 09-50-8031 (USA); 09-91-0300 (UK) PINS: 08-52-0113
DC Outputs	Molex 09-50-8061 (USA); 09-91-0600 (UK) PINS: 08-52-0113

Connector Kit #70-841-006, includes all of the above

1. Specifications subject to change without notice.
2. All dimensions in inches (mm), tolerance is ±0.02" (±0.5mm).
3. Mounting holes M1 and M2 should be grounded for EMI purposes.
4. Mounting hole M1 is safety ground connection.
5. Specifications are for convection rating at factory settings at 115 Vac input, 25°C unless otherwise stated.
6. Warranty: 2 year
7. Weight: 0.41 lb/0.18 kg



Phone: (800) 377-4384
Email: tech@solahd.com
www.solahd.com

SOLAHD GLS50 Series, GLS50-M Series Installation & Operating Instructions

Installation & Safety

To comply with the published safety standards, the following must be observed when using this power supply:

1. Maximum ambient temperature for the power supply must not exceed 50°C. The power supply has been evaluated for use in 70°C at half load (27.5) for GLS52 only; (30 W) for GLS53, GLS54, GLS55, and GLS58 only.
2. When installing the power supply in the end-use equipment, special attention is required to ensure safety compliance with the following safety standards: UL60950-1, EN60950-1, IEC60950-1, and CSA22.2 No. 60950-1-03 for GLS52, GLS53, GLS54, GLS55, and GLS58; UL60601-1, EN60601-1, IEC60601-1, and CSA22.2 No. 60601-1-M90 for GLS52-M, GLS53-M, GLS54-M, GLS55-M, and GLS58-M. The safety requirements include creepage distances, clearances, and distance through insulation between primary wiring and earth or secondary (SELV) wiring.
3. This power supply is approved and certified for the rated voltage range of 100 V ac to 240 V ac.
4. The maximum output power of the supply must not exceed the rating indicated in the specification sheet.
5. The disconnection from the line must be in the end system.
6. The internal fuse should only be replaced with a T3.15AH, 250 V ac, type TE5/392 manufactured by Wickmann.
NOTE: The power supply has a fuse on the neutral line for GLS52-M, GLS53-M, GLS54-M, GLS55-M, and GLS58-M.
7. GLS52-M, GLS53-M, GLS54-M, GLS55-M, and GLS58-M have no patient applied part.
8. This equipment is considered Class I according to protection against electric shock.
9. This power supply is  marked following the provisions of the Low Voltage Directive, 2006/95/EC.

For technical assistance, contact SolaHD Technical Support at (800) 377-4384 or send an e-mail to tech@solahd.com. Please visit our Web site at www.solahd.com for additional product information and specification sheets.

Output Ratings

Model	Output Voltage (V)	Convection Cooling	
		Max. Output Current (A)	Max. Output Power (W)
GLS52 (-M)	+5	11.0	55
GLS53 (-M)	+12	5.0	60
GLS54 (-M)	+15	4.0	
GLS55 (-M)	+24	2.5	
GLS58 (-M)	+48	1.25	

Connector PIN Designation

Input Connector	PIN	GLS52 (-M)	GLS53 (-M)	GLS54 (-M)	GLS55 (-M)	GLS58 (-M)
SK1	1	Line				
	3	Neutral				
Output Connector	PIN	GLS52 (-M)	GLS53 (-M)	GLS54 (-M)	GLS55 (-M)	GLS58 (-M)
SK2	1	+5 V	+12 V	+15 V	+24 V	+48 V
	2	+5 V	+12 V	+15 V	+24 V	+48 V
	3	Common				
	4	Common				
	5	-Sense				
	6	+Sense				

SOLAHD GLS50 Series, GLS50-M Series Installation & Operating Instructions

Mechanical Outline & Dimensions

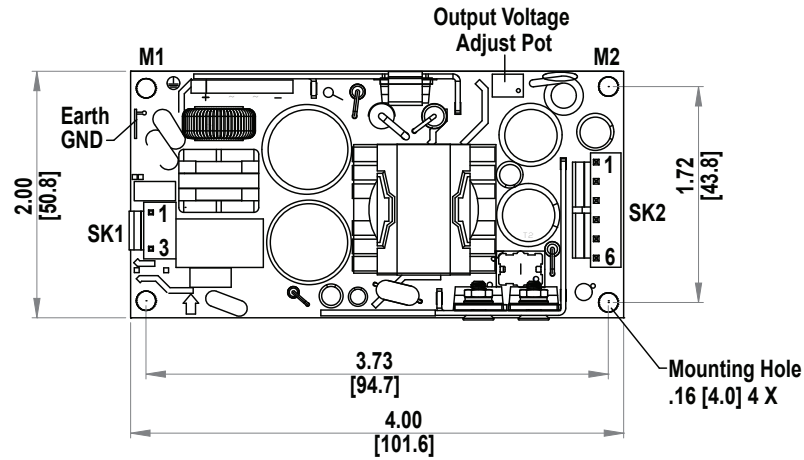

Top View

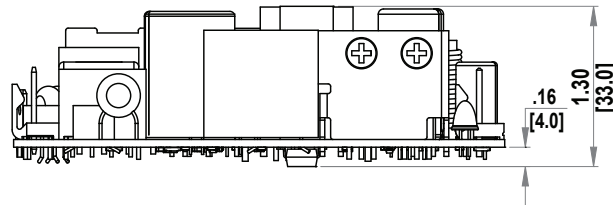

Side View

All dimensions are in inches [mm].

Maximum screw head diameter is .22" [5.6 mm].

Mounting holes M1 and M2 should be grounded for EMI purposes. Mounting hole M1 is an earth ground connection.

CAUTION! Do not accidentally connect the ac connector to the dc output.

EMI/RFI	EN55022 Class B conducted; VDE 0878 PT3 Class B conducted
Safety ground leakage current	<0.5 mA @ 50/60 Hz, 264 Vac input for class I; < 0.25 mA @ 50/60 Hz; 264 Vac input for class II GLS50-M: 275 uA @ 50/60 Hz; 264 Vac input
Output	
Maximum power	60 W convection; (GLS52, 55 W)
Adjustment range	±20% minimum
Hold-up time	10/20 ms 115/230 Vac input line
Overload protection	Short circuit protection on all outputs Case overload protected @ 110-160% of normal rating
Overvoltage protection	30-50% above nominal output
Remote sense	Compensates for 0.5 lead V lead drop max. Will operate without remote sense. Reverse connection protected.

Environmental Specifications

Operating temperature	0° to 50°C ambient. Derate each output 2.5% per degree from 50° to 70°C. -20°C start up.
Storage temperature	-40°C to 85°C
Electromagnetic susceptibility	Designed to meet EN61000-4; -2, -3, -4, -5, -6, -8, -11 Level 3
Humidity	Operating; non-condensing 10% to 95% RH
Vibration	IEC68-2-6 to the levels of IEC721-3-2
MTBF demonstrated	> 550,000 hours at full load and 25°C ambient conditions

Mating Connectors

AC Input	Molex 09-50-8031 (USA); 09-91-0300 (UK) PINS: 08-52-0113
DC Outputs	Molex 09-50-8061 (USA); 09-91-0600 (UK) PINS: 08-52-0113

Connector Kit #70-841-006, includes all of the above

1. Specifications subject to change without notice.
2. All dimensions in inches (mm), tolerance is ±0.02" (±0.5mm).
3. Mounting holes M1 and M2 should be grounded for EMI purposes.
4. Mounting hole M1 is safety ground connection.
5. Specifications are for convection rating at factory settings at 115 Vac input, 25°C unless otherwise stated.
6. Warranty: 2 year
7. Weight: 0.41 lb/0.18 kg



Phone: (800) 377-4384
Email: tech@solahd.com
www.solahd.com

SOLAHD GLS53-I Installation & Operating Instructions

To comply with the published safety standards, the following must be observed when using this power supply:

1. Maximum ambient temperature for the power supply must not exceed 50°C. The power supply has been evaluated for use in 70°C at half load and 80°C at quarter load.
2. When installing the power supply in the end-use equipment, special attention is required to ensure safety compliance with the following safety standards: UL60950-1, EN60950-1, IEC60950-1, and CSA22.2 No. 60950-1-03. The safety requirements include creepage distances, clearances, and distance through insulation between primary wiring and earth or secondary (SELV) wiring.
3. This power supply is approved and certified for the rated voltage range of 100 V ac to 240 V ac.
4. The maximum output power of the supply must not exceed the rating indicated in the specification sheet.
5. The disconnection from the line must be in the end system.
6. The unit must be protected with dc rated fuse when operating in a dc input voltage.
7. The internal fuse should only be replaced with a 3.15A, 250 V ac, type TE5/392 manufactured by Wickmann.
8. This equipment is considered Class I according to protection against electric shock.
9. This power supply is **CE** marked following the provisions of the Low Voltage Directive, 2006/95/EC.
10. For technical assistance, contact SolaHD Technical Support at (800) 377-4384 or send an e-mail to tech@solahd.com. Please visit our Web site at www.solahd.com for additional product information and specification sheets.

Output Ratings

Output Voltage (V)	Convection Cooling	
	Max. Output Current (A)	Max. Output Power (W)
+12	5.0	60

Connector PIN Designation

Input Connector	PIN	Designation
SK1	1	Line
	3	Neutral
Output Connector	PIN	Designation
SK2	1	+12 V
	2	+12 V
	3	Common
	4	Common
	5	-Sense
	6	+Sense

Mechanical Outline & Dimensions

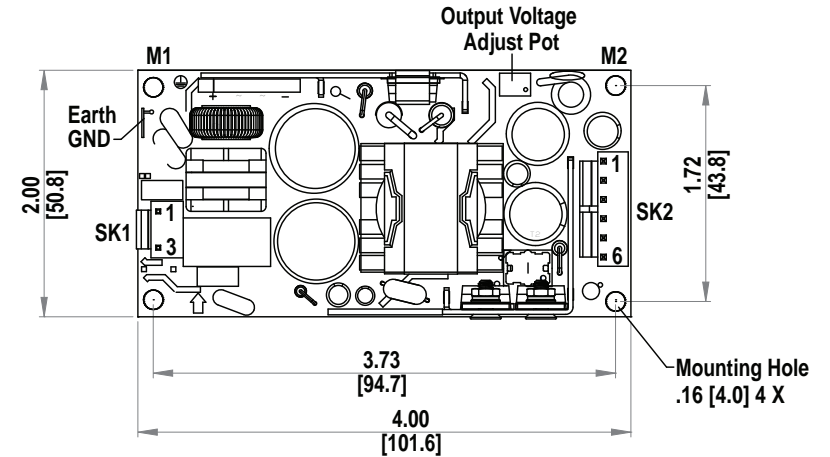

Top View

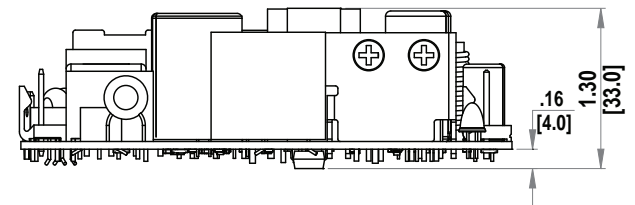

Side View

All dimensions are in inches [mm].

Maximum screw head diameter is .22" [5.6 mm].

Mounting holes M1 and M2 should be grounded for EMI purposes. Mounting hole M1 is an earth ground connection.

CAUTION! Do not accidentally connect the ac connector to the dc output.



EMI/RFI	EN55022 Class B conducted; VDE 0878 PT3 Class B conducted
Safety ground leakage current	<0.5 mA @ 50/60 Hz, 264 Vac input for class I; < 0.25 mA @ 50/60 Hz; 264 Vac input for class II GLS50-M: 275 uA @ 50/60 Hz; 264 Vac input
Output	
Maximum power	60 W convection; (GLS52, 55 W)
Adjustment range	±20% minimum
Hold-up time	10/20 ms 115/230 Vac input line
Overload protection	Short circuit protection on all outputs Case overload protected @ 110-160% of normal rating
Overvoltage protection	30-50% above nominal output
Remote sense	Compensates for 0.5 lead V lead drop max. Will operate without remote sense. Reverse connection protected.

Environmental Specifications

Operating temperature	0° to 50°C ambient. Derate each output 2.5% per degree from 50° to 70°C. -20°C start up.
Storage temperature	-40°C to 85°C
Electromagnetic susceptibility	Designed to meet EN61000-4; -2, -3, -4, -5, -6, -8, -11 Level 3
Humidity	Operating; non-condensing 10% to 95% RH
Vibration	IEC68-2-6 to the levels of IEC721-3-2
MTBF demonstrated	> 550,000 hours at full load and 25°C ambient conditions

Mating Connectors

AC Input	Molex 09-50-8031 (USA); 09-91-0300 (UK) PINS: 08-52-0113
DC Outputs	Molex 09-50-8061 (USA); 09-91-0600 (UK) PINS: 08-52-0113

Connector Kit #70-841-006, includes all of the above

1. Specifications subject to change without notice.
2. All dimensions in inches (mm), tolerance is ±0.02" (±0.5mm).
3. Mounting holes M1 and M2 should be grounded for EMI purposes.
4. Mounting hole M1 is safety ground connection.
5. Specifications are for convection rating at factory settings at 115 Vac input, 25°C unless otherwise stated.
6. Warranty: 2 year
7. Weight: 0.41 lb/0.18 kg



Phone: (800) 377-4384
Email: tech@solahd.com
www.solahd.com

SOLAHD GLS54, GLS54-M Installation & Operating Instructions

To comply with the published safety standards, the following must be observed when using this power supply:

1. Maximum ambient temperature for the power supply must not exceed 50°C. The power supply has been evaluated for use in 70°C at half load (30 W) for GLS54 only.
2. When installing the power supply in the end-use equipment, special attention is required to ensure safety compliance with the following safety standards: UL60950-1, EN60950-1, IEC60950-1, and CSA22.2 No. 60950-1-03 for GLS54; UL60601-1, EN60601-1, IEC60601-1, and CSA22.2 No. 60601-1-M90 for GLS54-M. The safety requirements include creepage distances, clearances, and distance through insulation between primary wiring and earth or secondary (SELV) wiring.
3. This power supply is approved and certified for the rated voltage range of 100 V ac to 240 V ac.
4. The maximum output power of the supply must not exceed the rating indicated in the specification sheet.
5. The disconnection from the line must be in the end system.
6. The internal fuse should only be replaced with a T3.15AH, 250 V ac, type TE5/392 manufactured by Wickmann.
NOTE: The power supply has a fuse on the neutral line for GLS54-M.
7. GLS54-M has no patient applied part.
8. This equipment is considered Class I according to protection against electric shock.
9. This power supply is **CE** marked following the provisions of the Low Voltage Directive, 2006/95/EC.
10. For technical assistance, contact SolaHD Technical Support at (800) 377-4384 or send an e-mail to tech@solahd.com. Please visit our Web site at www.solahd.com for additional product information and specification sheets.

Output Ratings

Output Voltage (V)	Convection Cooling	
	Max. Output Current (A)	Max. Output Power (W)
+15	4.0	60

Connector PIN Designation

Input Connector	PIN	Designation
SK1	1	Line
	3	Neutral
Output Connector	PIN	Designation
SK2	1	+15 V
	2	+15 V
	3	Common
	4	Common
	5	-Sense
	6	+Sense

Mechanical Outline & Dimensions

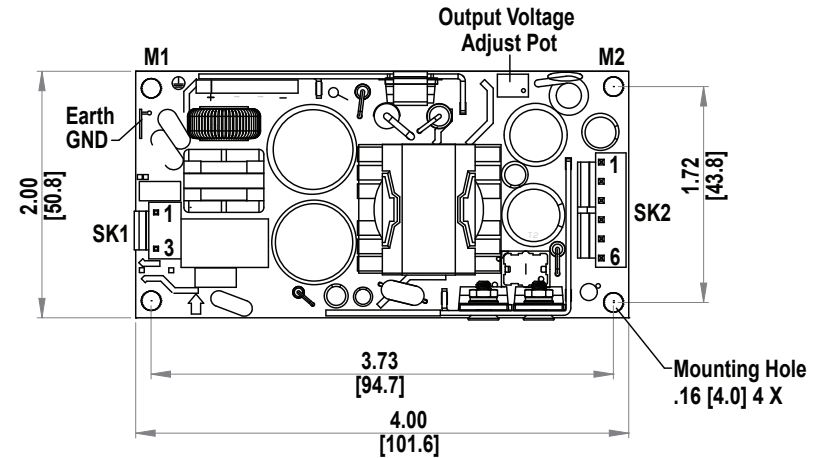

Top View

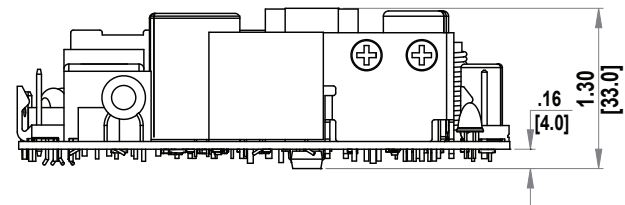

Side View

All dimensions are in inches [mm].

Maximum screw head diameter is .22" [5.6 mm].

Mounting holes M1 and M2 should be grounded for EMI purposes.

Mounting hole M1 is an earth ground connection.

CAUTION! Do not accidentally connect the ac connector to the dc output.

EMI/RFI	EN55022 Class B conducted; VDE 0878 PT3 Class B conducted
Safety ground leakage current	<0.5 mA @ 50/60 Hz, 264 Vac input for class I; < 0.25 mA @ 50/60 Hz; 264 Vac input for class II GLS50-M: 275 uA @ 50/60 Hz; 264 Vac input
Output	
Maximum power	60 W convection; (GLS52, 55 W)
Adjustment range	±20% minimum
Hold-up time	10/20 ms 115/230 Vac input line
Overload protection	Short circuit protection on all outputs Case overload protected @ 110-160% of normal rating
Overvoltage protection	30-50% above nominal output
Remote sense	Compensates for 0.5 lead V lead drop max. Will operate without remote sense. Reverse connection protected.

Environmental Specifications

Operating temperature	0° to 50°C ambient. Derate each output 2.5% per degree from 50° to 70°C. -20°C start up.
Storage temperature	-40°C to 85°C
Electromagnetic susceptibility	Designed to meet EN61000-4; -2, -3, -4, -5, -6, -8, -11 Level 3
Humidity	Operating; non-condensing 10% to 95% RH
Vibration	IEC68-2-6 to the levels of IEC721-3-2
MTBF demonstrated	> 550,000 hours at full load and 25°C ambient conditions

Mating Connectors

AC Input	Molex 09-50-8031 (USA); 09-91-0300 (UK) PINS: 08-52-0113
DC Outputs	Molex 09-50-8061 (USA); 09-91-0600 (UK) PINS: 08-52-0113

Connector Kit #70-841-006, includes all of the above

1. Specifications subject to change without notice.
2. All dimensions in inches (mm), tolerance is ±0.02" (±0.5mm).
3. Mounting holes M1 and M2 should be grounded for EMI purposes.
4. Mounting hole M1 is safety ground connection.
5. Specifications are for convection rating at factory settings at 115 Vac input, 25°C unless otherwise stated.
6. Warranty: 2 year
7. Weight: 0.41 lb/0.18 kg



Phone: (800) 377-4384
Email: tech@solahd.com
www.solahd.com

SOLAHD GLS55, GLS55-M Installation & Operating Instructions

To comply with the published safety standards, the following must be observed when using this power supply:

1. Maximum ambient temperature for the power supply must not exceed 50°C. The power supply has been evaluated for use in 70°C at half load (30 W) for GLS55 only.
 2. When installing the power supply in the end-use equipment, special attention is required to ensure safety compliance with the following safety standards: UL60950-1, EN60950-1, IEC60950-1, and CSA22.2 No. 60950-1-03 for GLS55; UL60601-1, EN60601-1, IEC60601-1, and CSA22.2 No. 60601-1-M90 for GLS55-M. The safety requirements include creepage distances, clearances, and distance through insulation between primary wiring and earth or secondary (SELV) wiring.
 3. This power supply is approved and certified for the rated voltage range of 100 V ac to 240 V ac.
 4. The maximum output power of the supply must not exceed the rating indicated in the specification sheet.
 5. The disconnection from the line must be in the end system.
 6. The internal fuse should only be replaced with a T3.15AH, 250 V ac, type TE5/392 manufactured by Wickmann.
- NOTE:** The power supply has a fuse on the neutral line for GLS55-M.
7. GLS55-M has no patient applied part.
 8. This equipment is considered Class I according to protection against electric shock.
 9. This power supply is **CE** marked following the provisions of the Low Voltage Directive, 2006/95/EC.
 10. For technical assistance, contact SolaHD Technical Support at (800) 377-4384 or send an e-mail to tech@solahd.com. Please visit our Web site at www.solahd.com for additional product information and specification sheets.

Output Ratings

Output Voltage (V)	Convection Cooling	
	Max. Output Current (A)	Max. Output Power (W)
+24	2.5	60

Connector PIN Designation

Input Connector	PIN	Designation
SK1	1	Line
	3	Neutral
Output Connector	PIN	Designation
SK2	1	+24 V
	2	+24 V
	3	Common
	4	Common
	5	-Sense
	6	+Sense

Mechanical Outline & Dimensions

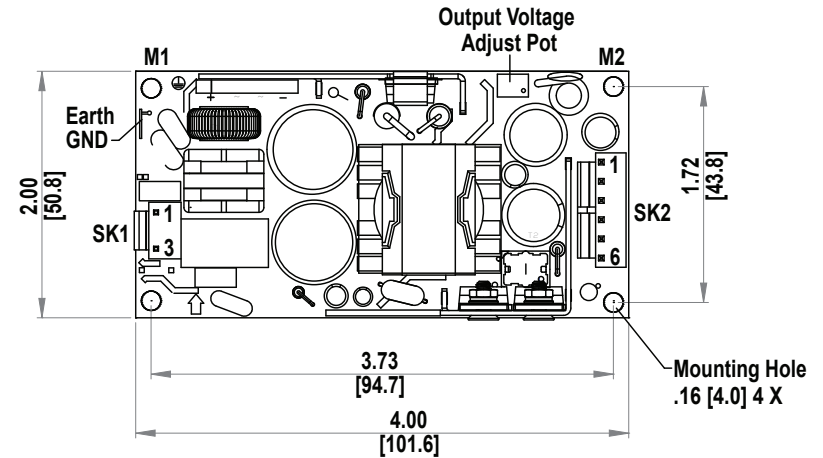

Top View

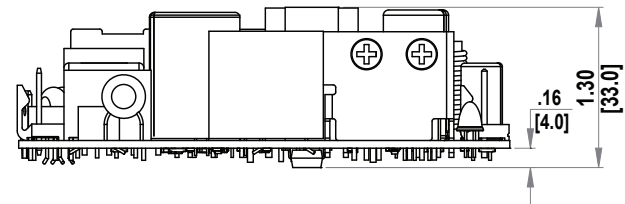

Side View

All dimensions are in inches [mm].

Maximum screw head diameter is .22" [5.6 mm].

Mounting holes M1 and M2 should be grounded for EMI purposes.

Mounting hole M1 is an earth ground connection.

CAUTION! Do not accidentally connect the ac connector to the dc output.

EMI/RFI	EN55022 Class B conducted; VDE 0878 PT3 Class B conducted
Safety ground leakage current	<0.5 mA @ 50/60 Hz, 264 Vac input for class I; < 0.25 mA @ 50/60 Hz; 264 Vac input for class II GLS50-M: 275 uA @ 50/60 Hz; 264 Vac input
Output	
Maximum power	60 W convection; (GLS52, 55 W)
Adjustment range	±20% minimum
Hold-up time	10/20 ms 115/230 Vac input line
Overload protection	Short circuit protection on all outputs Case overload protected @ 110-160% of normal rating
Overvoltage protection	30-50% above nominal output
Remote sense	Compensates for 0.5 lead V lead drop max. Will operate without remote sense. Reverse connection protected.

Environmental Specifications

Operating temperature	0° to 50°C ambient. Derate each output 2.5% per degree from 50° to 70°C. -20°C start up.
Storage temperature	-40°C to 85°C
Electromagnetic susceptibility	Designed to meet EN61000-4; -2, -3, -4, -5, -6, -8, -11 Level 3
Humidity	Operating; non-condensing 10% to 95% RH
Vibration	IEC68-2-6 to the levels of IEC721-3-2
MTBF demonstrated	> 550,000 hours at full load and 25°C ambient conditions

Mating Connectors

AC Input	Molex 09-50-8031 (USA); 09-91-0300 (UK) PINS: 08-52-0113
DC Outputs	Molex 09-50-8061 (USA); 09-91-0600 (UK) PINS: 08-52-0113

Connector Kit #70-841-006, includes all of the above

1. Specifications subject to change without notice.
2. All dimensions in inches (mm), tolerance is ±0.02" (±0.5mm).
3. Mounting holes M1 and M2 should be grounded for EMI purposes.
4. Mounting hole M1 is safety ground connection.
5. Specifications are for convection rating at factory settings at 115 Vac input, 25°C unless otherwise stated.
6. Warranty: 2 year
7. Weight: 0.41 lb/0.18 kg



Phone: (800) 377-4384
Email: tech@solahd.com
www.solahd.com

SOLAHD GLS58, GLS58-M Installation & Operating Instructions

To comply with the published safety standards, the following must be observed when using this power supply:

1. Maximum ambient temperature for the power supply must not exceed 50°C. The power supply has been evaluated for use in 70°C at half load (30 W) for GLS58 only.
 2. When installing the power supply in the end-use equipment, special attention is required to ensure safety compliance with the following safety standards: UL60950-1, EN60950-1, IEC60950-1, and CSA22.2 No. 60950-1-03 for GLS58; UL60601-1, EN60601-1, IEC60601-1, and CSA22.2 No. 60601-1-M90 for GLS58-M. The safety requirements include creepage distances, clearances, and distance through insulation between primary wiring and earth or secondary (SELV) wiring.
 3. This power supply is approved and certified for the rated voltage range of 100 V ac to 240 V ac.
 4. The maximum output power of the supply must not exceed the rating indicated in the specification sheet.
 5. The disconnection from the line must be in the end system.
 6. The internal fuse should only be replaced with a T3.15AH, 250 V ac, type TE5/392 manufactured by Wickmann.
- NOTE:** The power supply has a fuse on the neutral line for GLS58-M.
7. GLS58-M has no patient applied part.
 8. This equipment is considered Class I according to protection against electric shock.
 9. This power supply is **CE** marked following the provisions of the Low Voltage Directive, 2006/95/EC.
 10. For technical assistance, contact SolaHD Technical Support at (800) 377-4384 or send an e-mail to tech@solahd.com. Please visit our Web site at www.solahd.com for additional product information and specification sheets.

Output Ratings

Output Voltage (V)	Convection Cooling	
	Max. Output Current (A)	Max. Output Power (W)
+48	1.25	60

Connector PIN Designation

Input Connector	PIN	Designation
SK1	1	Line
	3	Neutral
Output Connector	PIN	Designation
SK2	1	+48 V
	2	+48 V
	3	Common
	4	Common
	5	-Sense
	6	+Sense

Mechanical Outline & Dimensions

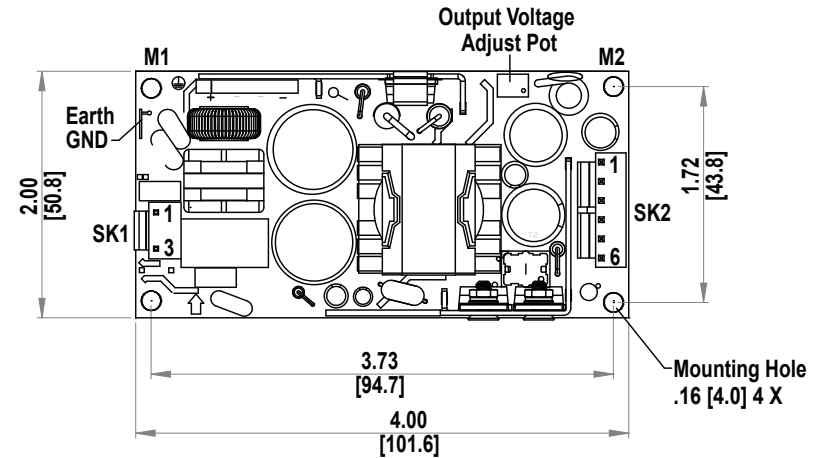

Top View

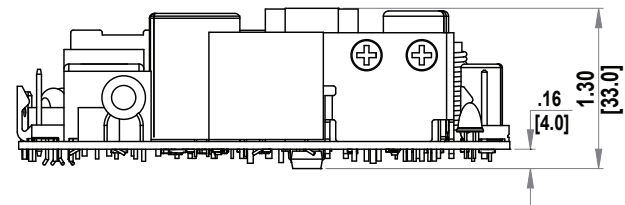

Side View

All dimensions are in inches [mm].

Maximum screw head diameter is .22" [5.6 mm].

Mounting holes M1 and M2 should be grounded for EMI purposes.

Mounting hole M1 is an earth ground connection.

CAUTION! Do not accidentally connect the ac connector to the dc output.

EMI/RFI	EN55022 Class B conducted; VDE 0878 PT3 Class B conducted
Safety ground leakage current	<0.5 mA @ 50/60 Hz, 264 Vac input for class I; < 0.25 mA @ 50/60 Hz; 264 Vac input for class II GLS50-M: 275 uA @ 50/60 Hz; 264 Vac input
Output	
Maximum power	60 W convection; (GLS52, 55 W)
Adjustment range	±20% minimum
Hold-up time	10/20 ms 115/230 Vac input line
Overload protection	Short circuit protection on all outputs Case overload protected @ 110-160% of normal rating
Overvoltage protection	30-50% above nominal output
Remote sense	Compensates for 0.5 lead V lead drop max. Will operate without remote sense. Reverse connection protected.

Environmental Specifications

Operating temperature	0° to 50°C ambient. Derate each output 2.5% per degree from 50° to 70°C. -20°C start up.
Storage temperature	-40°C to 85°C
Electromagnetic susceptibility	Designed to meet EN61000-4; -2, -3, -4, -5, -6, -8, -11 Level 3
Humidity	Operating; non-condensing 10% to 95% RH
Vibration	IEC68-2-6 to the levels of IEC721-3-2
MTBF demonstrated	> 550,000 hours at full load and 25°C ambient conditions

Mating Connectors

AC Input	Molex 09-50-8031 (USA); 09-91-0300 (UK) PINS: 08-52-0113
DC Outputs	Molex 09-50-8061 (USA); 09-91-0600 (UK) PINS: 08-52-0113

Connector Kit #70-841-006, includes all of the above

1. Specifications subject to change without notice.
2. All dimensions in inches (mm), tolerance is ±0.02" (±0.5mm).
3. Mounting holes M1 and M2 should be grounded for EMI purposes.
4. Mounting hole M1 is safety ground connection.
5. Specifications are for convection rating at factory settings at 115 Vac input, 25°C unless otherwise stated.
6. Warranty: 2 year
7. Weight: 0.41 lb/0.18 kg



Phone: (800) 377-4384
Email: tech@solahd.com
www.solahd.com

To comply with the published safety standards, the following must be observed when using this power supply:

- Maximum ambient temperature for the power supply must not exceed 50°C.
- When installing the power supply in the end-use equipment, special attention is required to ensure safety compliance with the following safety standards: UL60950-1, EN60950-1, IEC60950-1, and CSA22.2 No. 60950-1-03 for GLS62, GLS63, GLS64, and GLS65; UL60601-1, EN60601-1, IEC60601-1, and CSA22.2 No. 60601-1-M90 for GLS63-M, GLS64-M, and GLS65-M. The safety requirements include creepage distances, clearances, and distance through insulation between primary wiring and earth or secondary (SELV) wiring.
- The power supply's rated input voltage is automatically selected for GLS62, GLS63, GLS64, and GLS65. Please refer to the specification sheet for the input voltage range. GLS63-M, GLS64-M, and GLS65-M are approved and certified for the rated voltage range of 100 V ac to 250 V ac and/or 140 V dc to 300 V dc.
- The maximum output power of the supply must not exceed the rating indicated in the specification sheet.
- The earth ground wire must be connected only to the point marked with the earth ground symbol (on the unit).
- The disconnection from the line must be in the end system.
- Hazardous voltages exist in the primary circuits. Disconnect the power supply before servicing.
- When operating with a dc input voltage range, the unit input must be protected by a dc rated fuse in the end-use installation system.
- The internal fuse should only be replaced with a 3.15 A, 250 V ac, type SP0001.1009 manufactured by Schurter AG, type 2163.15 manufactured by Littelfuse, or type S501 manufactured by Cooper.
- This power supply is not suitable for direct contact to the patient.
- This equipment is considered Class I according to protection against electric shock.
- This power supply is **CE** marked following the provisions of the Low Voltage Directive, 2006/95/EC.
- For technical assistance, contact SolaHD Technical Support at (800) 377-4384 or send an e-mail to tech@solahd.com. Please visit our Web site at www.solahd.com for additional product information and specification sheets.

Mechanical Outline

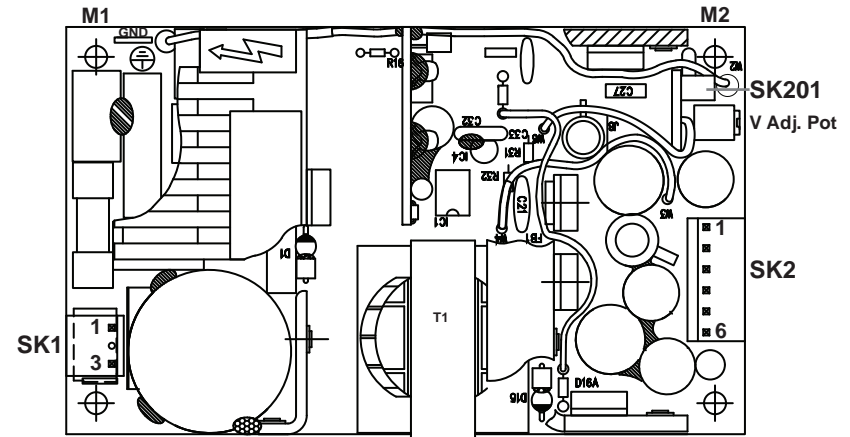

Connector PIN Designation

Input Connector	PIN	GLS62	GLS63 (-M)	GLS64 (-M)	GLS65 (-M)
SK1	1	Neutral			
	3	Line			
Output Connector	PIN	GLS62	GLS63 (-M)	GLS64 (-M)	GLS65 (-M)
SK2	1	+5 V	+12 V	+15 V	+24 V
	2				
	3				
	4	Common			
	5				
	6				
SK201	1	+Sense			
	2	-Sense			

NOTE: Mounting holes M1 and M2 should be grounded for EMI purposes. Mounting hole M1 is a safety ground connection.

Output Ratings

Model	Output Voltage (V)	Convection Cooling		30 CFM Forced Air Cooling	
		Max. Output Current (A)	Max. Output Power (W)	Max. Output Current (A)	Max. Output Power (W)
GLS62	+5	12.0	60	16.0	80
GLS63 (-M)	+12	5.0		6.7	
GLS64 (-M)	+15	4.0		5.3	
GLS65 (-M)	+24	2.5		3.3	

Mechanical Dimensions

Bottom View

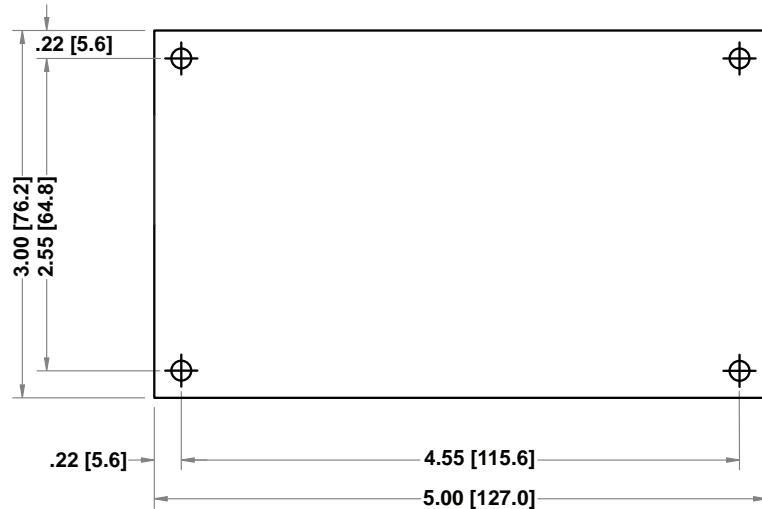

Side View

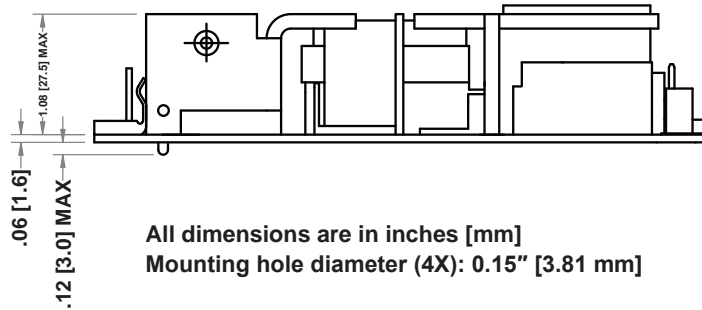

Typical Ventilation Setup

Top View

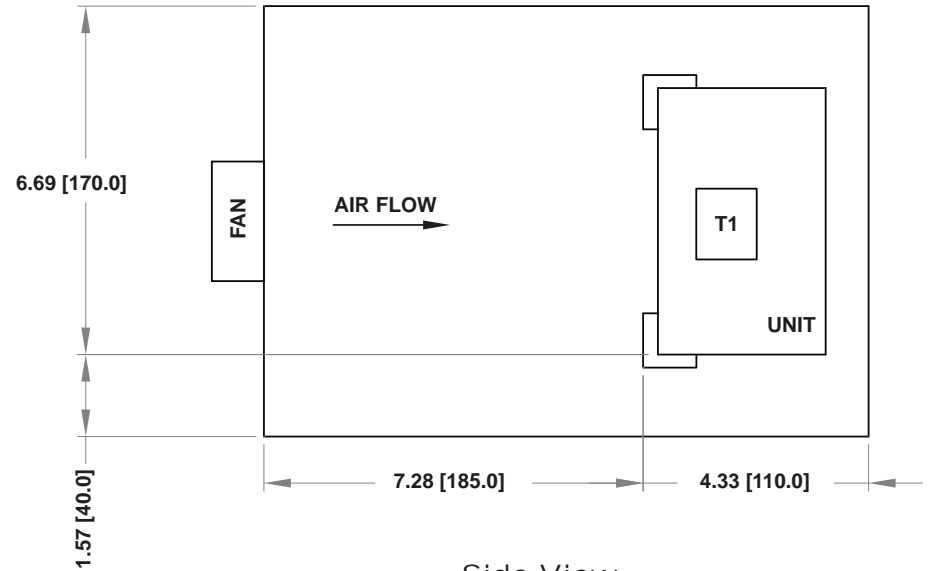

Side View

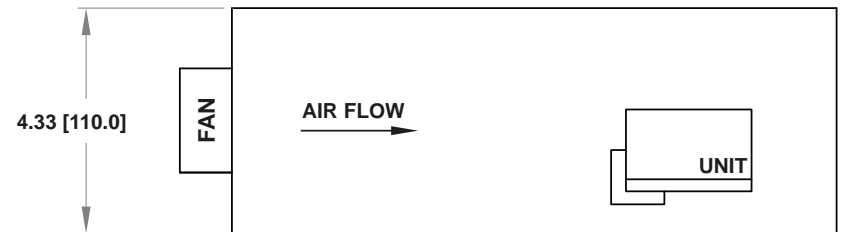

Fan: MINEBEA 3110NL-04W-B30

Fan Input: 12 V dc

NOTE: Dimensions and fan used are for reference only

EMI filter	FCC Class B conducted; CISPR 22 Class B conducted; EN55022 Class B conducted; VDE 0878 PT3 Class B conducted
Safety ground leakage current	<0.5 mA @ 50/60 Hz, 264 Vac input
Output	
Maximum power	60 W convection; 80 W with 30 CFM forced air
Adjustment range	-5, 10% min.
Hold-up time	20 ms @ 60 W load, 115 Vac nominal line
Overload protection	Short circuit protection on all outputs. Case overload protected @ 110-145% above peak rating
Overvoltage protection	5 V output; 5.7 to 6.7 Vdc; Other outputs 10% to 25% above nominal output
Remote sense	Compensates for 0.5 V lead drop minimum, will operate without remote sense connected. Reverse connection protected

Environmental Specifications

Operating temperature	0° to 50°C ambient. Derate each output 2.5% per degree from 50° to 70°C, -20°C startup
Storage temperature	-40°C to 85°C
Temperature coefficient	±0.04% per °C
Electromagnetic susceptibility	Designed to meet IEC 801, -2, -3, -4, -5, -6, Level 3
Humidity	Operating; non-condensing 5% to 95% RH
Vibration	Three orthogonal axes, sweep at 1 oct/min, 5 min. dwell at four major resonances 0.75G peak 5 Hz to 500 Hz, operational
MTBF demonstrated	>550,000 hours at full load and 25°C ambient conditions

Mating Connectors

AC Input	Molex 09-50-8031 (USA) Not required for (-T) option 09-91-0300 (UK); PINS: 08-58-0111
DC Outputs	Molex 09-50-8061 (USA) Not required for (-T) option 09-91-0600 (UK); PINS: 08-58-0113
Remote Sense	Molex 22-01-2025 PINS: 08-52-0113

Connector Kit #70-841-006, includes all of the above

- Specifications subject to change without notice.
- All dimensions in inches (mm), tolerance is ±0.02" (±0.5mm).
- Mounting holes M1 and M2 should be grounded for EMI purposes.
- Mounting hole M1 is safety ground connection.
- Specifications are for convection rating at factory settings at 115 Vac input, 25°C unless otherwise stated.
- Warranty: 2 year
- Weight: 0.75 lb/0.34 kg

Power Derating Curve

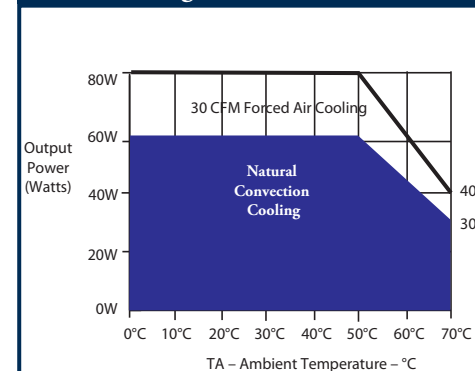

Phone: (800) 377-4384
Email: tech@solahd.com
www.solahd.com

SOLAHD GLT20 Series Installation & Operating Instructions

Installation & Safety

To comply with the published safety standards, the following must be observed when using this power supply:

1. Maximum ambient temperature for the power supply must not exceed 50°C.
2. When installing the power supply in the end-use equipment, special attention is required to ensure safety compliance with the following safety standards: UL60950-1, EN60950-1, IEC60950-1, and CSA22.2 No. 60950-1-03; including the requirements for creepage distances, clearances, and distance through insulation between primary wiring and earth or secondary (SELV) wiring.
3. The power supply's rated input voltage is automatically selected. Please refer to the specification sheet for the input voltage range.
4. The maximum output power of the supply must not exceed the rating indicated in the specification sheet.
5. The earth ground wire must be connected only to the point marked with the earth ground symbol (on the unit).
6. Hazardous voltages exist in the primary circuits. Disconnect the power supply before servicing.
7. When operating with a dc input voltage range, the unit input must be protected by a dc rated fuse in the end-use installation system.
8. The internal fuse should only be replaced with a 2.5 A, 250 V ac, type SP0001.1008 manufactured by Schurter AG or type 21602.5 manufactured by Littelfuse.
9. This equipment is considered Class I according to protection against electric shock.
10. This power supply is **CE** marked following the provisions of the Low Voltage Directive, 2006/95/EC.

For technical assistance, contact SolaHD Technical Support at (800) 377-4384 or send an e-mail to tech@solahd.com. Please visit our Web site at www.solahd.com for additional product information and specification sheets.

Mechanical Outline

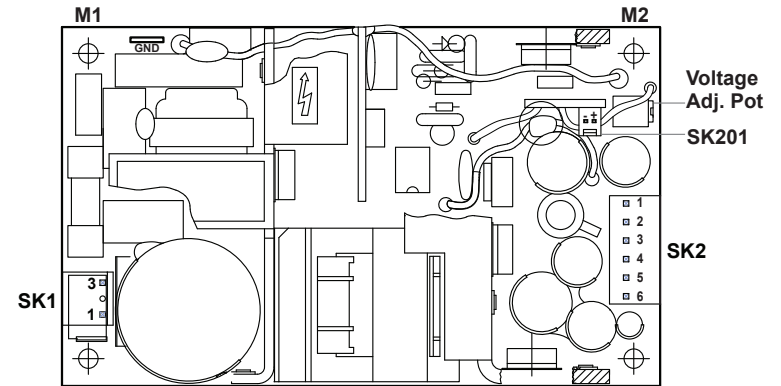

Connector PIN Designation

Input Connector	PIN	GLT22	GLT23	GLT24	GLT25
SK1	1	Line			
	3	Neutral			
Output Connector	PIN	GLT22	GLT23	GLT24	GLT25
SK2	1	+12 V			+15 V
	2	+5 V			
	3	+5 V			
	4	Common			
	5	Common			
	6	-12 V	-12 V	-5 V	-15 V
SK201	1	+Sense			
	2	-Sense			

NOTE: Mounting holes M1 and M2 should be grounded for EMI purposes. Mounting hole M1 is an earth ground connection.

Output Ratings

Model	Output Voltage (V)	Convection Cooling		30 CFM Forced Air Cooling	
		Max. Output Current (A)	Max. Output Power (W)	Max. Output Current (A)	Max. Output Power (W)
GLT22	+5	3.0	25	4.0	40
	+12	1.5		2.0	
	-12	0.5		0.7	
GLT23	+5	4.0		5.0	
	+12	0.5		0.7	
	-12	0.5		0.7	
GLT24	+5	3.0		4.0	
	+12	1.5		2.0	
	-5	0.5		0.7	
GLT25	+5	3.0		4.0	
	+15	1.5		2.0	
	-15	0.5		0.7	

SOLAHD GLT20 Series Installation & Operating Instructions

Mechanical Dimensions

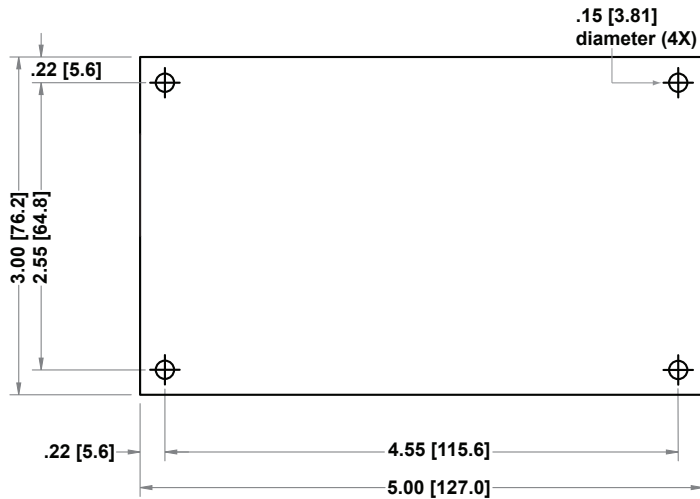

Bottom View

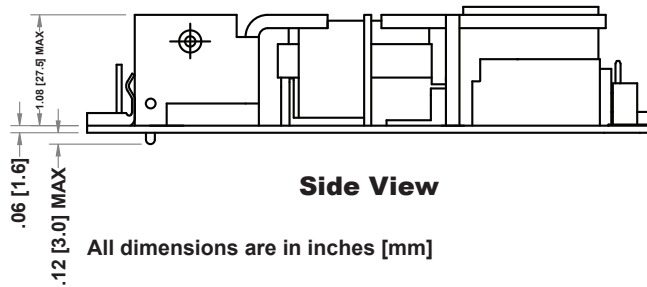

Side View

All dimensions are in inches [mm]

Typical Ventilation Setup

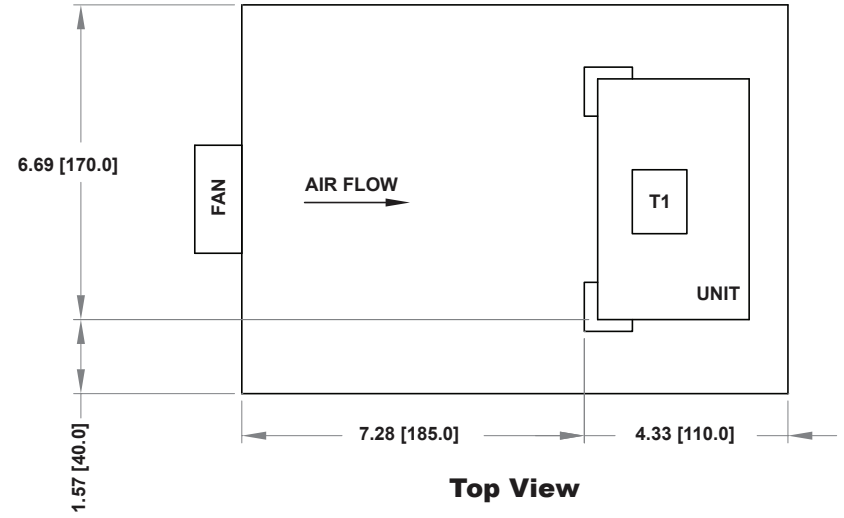

Top View

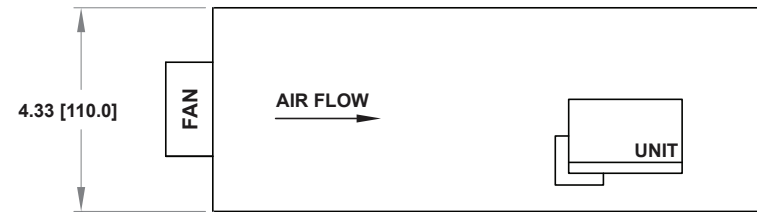

Side View

Fan: MINEBEA 3110NL-04W-B30

Fan Input: 12 V dc

NOTE: Dimensions and fan used are for reference only



Safety ground leakage current	<0.5 mA @ 50/60 Hz, 264 Vac input
-------------------------------	-----------------------------------

Output	
Maximum power	25 W for convection; 40 W with 30 CFM forced air
Cross regulation	±2% on output 1; ±5% on outputs 2, 3
Adjustment range	-5, +10% minimum
Hold-up time	20 ms @ 25 W load, 115 Vac nominal line
Overload protection	Short circuit protection on all outputs Case overload protected @ 110-145% above peak rating
Overvoltage protection	5.7 to 6.7 Vdc on the main output
Minimum Load	0.3 A first output, 0.1 A second output: GLT22, GLT24, GLT25; 0.4A first output: GLT23
Remote Sense	Compensates for 0.5 V lead drop minimum; Will operate without remote sense connected. Reverse connection protected.

Environmental Specifications

Operating temperature	0° to 50°C ambient. Derate each output 2.5% per degree from 50° to 70°C, -20°C start up.
Storage temperature	-40°C to 85°C
Temperature coefficient	±.04% per °C
Electromagnetic susceptibility	Designed to meet IEC 801, -2, -3, -4, -5, -6, Level 3
Humidity	Operating; non-condensing 5% to 95%
Vibration	Three orthogonal axes, sweep at 1 oct/min, 5 min. dwell at four major resonances 0.75G peak 5 Hz to 500 Hz, operational
MTBF demonstrated	>550,000 hours at full load and 25°C ambient conditions

Mating Connectors

AC Input	Molex 09-50-8031 (USA) Not required for (-T) option 09-91-0300 (UK); PINS: 08-52-0113
DC Outputs	Molex 09-50-8061 (USA) Not required for (-T) option 09-91-0600 (UK); PINS: 08-52-0113
Remote Sense	Molex 22-01-2025; PINS: 08-52-0123

Connector Kit #70-841-006, includes all of the above

- Specifications subject to change without notice.
- All dimensions in inches (mm), tolerance is ±0.02" (±0.5mm).
- Mounting holes M1 and M2 should be grounded for EMI purposes.
- Mounting hole M1 is safety ground connection.
- Specifications are for convection rating at factory settings at 115 Vac input, 25°C unless otherwise stated.
- Warranty: 2 year
- Weight: 0.5lb/0.23kg

Power Derating Curve

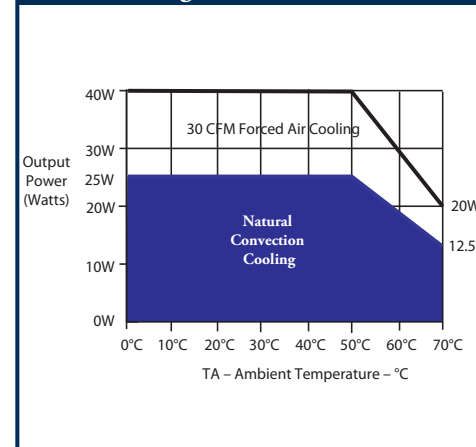

SOLAHD GLT40 Series, GLT40-M Series Installation & Operating Instructions

Installation & Safety

To comply with the published safety standards, the following must be observed when using this power supply:

1. Maximum ambient temperature for the power supply must not exceed 50°C.
2. When installing the power supply in the end-use equipment, special attention is required to ensure safety compliance with the following safety standards: UL60950-1, EN60950-1, IEC60950-1, and CSA22.2 No. 60950-1-03 for GLT42, GLT43, GLT44, GLT45, and GLT46; UL60601-1, EN60601-1, IEC60601-1, and CSA22.2 No. 60601-1-M90 for GLT42-M and GLT45-M. The safety requirements include creepage distances, clearances, and distance through insulation between primary wiring and earth or secondary (SELV) wiring.
3. The power supply's rated input voltage is automatically selected. Please refer to the specification sheet for the input voltage range.
4. The maximum output power of the supply must not exceed the rating indicated in the specification sheet.
5. The earth ground wire must be connected only to the point marked with the earth ground symbol (on the unit).
6. Hazardous voltages exist in the primary circuits. Disconnect the power supply before servicing.
7. When operating with a dc input voltage range, the unit input must be protected by a dc rated fuse in the end-use installation system.
8. The internal fuse should only be replaced with a 2.5 A, 250 V ac, type SP0001.1008 manufactured by Schurter AG or type 21602.5 manufactured by Littelfuse.
9. GLT42-M and GLT45-M have no patient applied part.
10. This equipment is considered Class I according to protection against electric shock.
11. This power supply is **CE** marked following the provisions of the Low Voltage Directive, 2006/95/EC.

For technical assistance, contact SolaHD Technical Support at (800) 377-4384 or send an e-mail to tech@solahd.com. Please visit our Web site at www.solahd.com for additional product information and specification sheets.

Mechanical Outline

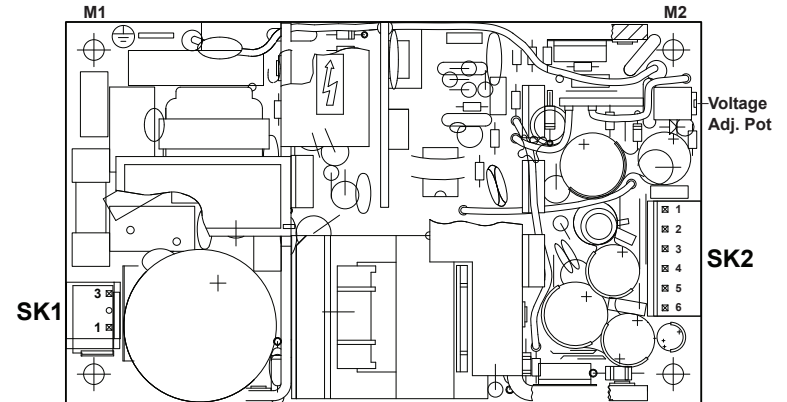

Connector PIN Designation

Input Connector	PIN	GLT42 (-M)	GLT43	GLT44	GLT45 (-M)	GLT46
SK1	1			Line		
	3			Neutral		
Output Connector	PIN	GLT42 (-M)	GLT43	GLT44	GLT45 (-M)	GLT46
SK2	1		+12 V		+15 V	+24 V
	2			+5 V		
	3					
	4					
	5			Common		
	6	-12 V	-12 V	-5 V	-15 V	+12 V
SK201	1			+Sense		
	2			-Sense		

NOTE: Mounting holes M1 and M2 should be grounded for EMI purposes. Mounting hole M1 is an earth ground connection.

Output Ratings

Model	Output Voltage (V)	Convection Cooling		30 CFM Forced Air Cooling	
		Max. Output Current (A)	Max. Output Power (W)	Max. Output Current (A)	Max. Output Power (W)
GLT42 (-M)	+5	4.0	40	5.0	55
	+12	2.0		2.5	
	-12	0.5		0.7	
GLT43	+5	6.0		8.0	
	+12	0.5		0.7	
	-12	0.5		0.7	
GLT44	+5	4.0		5.0	
	+12	2.0		2.5	
	-5	0.5		0.7	
GLT45 (-M)	+5	4.0		5.0	
	+15	2.0		2.5	
	-15	0.5		0.7	
GLT46	+5	4.0	5.0		
	+24	1.0	1.5		
	+12	0.5	0.7		

SOLAHD GLT40 Series, GLT40-M Series Installation & Operating Instructions

Mechanical Dimensions

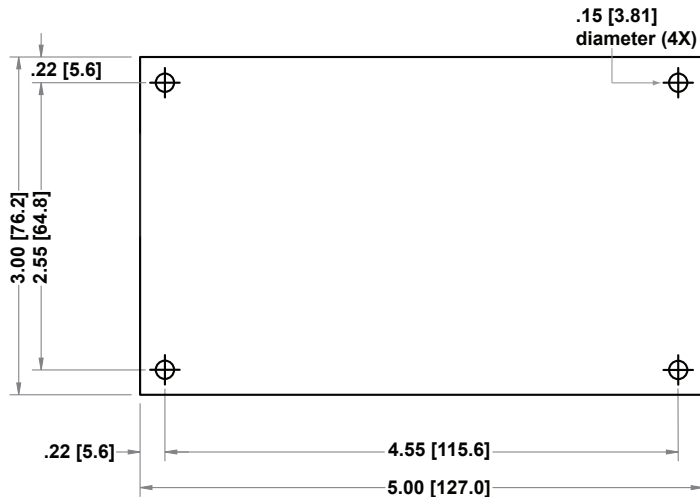

Bottom View

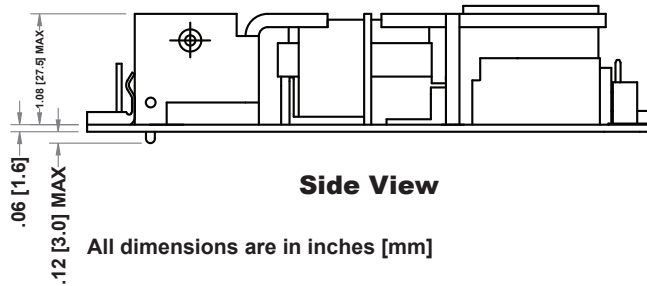

Side View

All dimensions are in inches [mm]

Typical Ventilation Setup

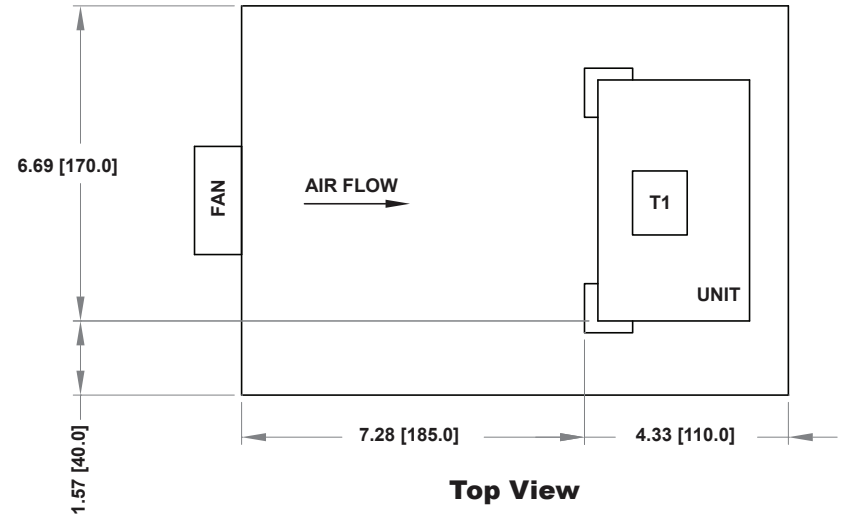

Top View

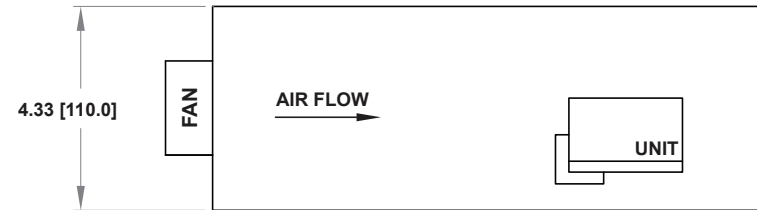

Side View

Fan: MINEBEA 3110NL-04W-B30

Fan Input: 12 V dc

NOTE: Dimensions and fan used are for reference only



EMI	EN55022 Class B conducted; VDE 0878 PT3 Class B conducted
Safety ground leakage current	<0.5 mA @ 50/60 Hz, 264 Vac input; GLT40-M: <75µA @ 50/60 Hz, 264 Vac input
Output	
Maximum power	40 W convection; 55 W with 30 CFM forced air
Cross regulation	±2% on output 1; ±5% on outputs 2, 3
Adjustment range	-5, +10% minimum
Hold-up time	20 ms @ 40 W load, 115 Vac nominal line
Overload protection	Short circuit protection on all outputs. Case overload protected @ 110-145% above peak rating
Overvoltage protection	5.7 to 6.7 Vdc on the main output
Minimum Load	0.4 A for first output, 0.2 A for second outputs: GLT42, GLT44, GLT45; 0.5 A for the 1st output of GLT43; 0.4 A for first output, 0.1 A for second outputs: GLT46
Remote sense	Compensates for 0.5 V lead drop min. Will operate without remote sense connected. Reverse connection protected.

Environmental Specifications

Operating temperature	0° to 50°C ambient. Derate each output 2.5% per degree from 50° to 70°C; -20°C start up.
Storage temperature	-40°C to 85°C
Temperature coefficient	±.04% per °C
Electromagnetic susceptibility	Designed to meet IEC 801, -2, -3, -4, -5, -6, Level 3
Humidity	Operating; non-condensing 5% to 95%
Vibration	Three orthogonal axes, sweep at 1 oct/min, 5 min. dwell at four major resonances 0.75 G peak 5 Hz to 500 Hz, operational
MTBF demonstrated	>550,000 hours at full load and 25°C ambient conditions

Mating Connectors

AC Input	Molex 09-50-8031 (USA) Not required for (-T) option; 09-91-0300 (UK) PINS: 08-52-0113
DC Outputs	Molex 09-50-8061 (USA) Not required for (-T) option; 09-91-0600 (UK) PINS: 08-52-0113
Remote Sense	Molex 22-01-2025; PINS 08-52-0123

Connector Kit #70-841-006, includes all of the above

1. Specifications subject to change without notice.
2. All dimensions in inches (mm), tolerance is ±0.02" (±0.5mm).
3. Mounting holes M1 and M2 should be grounded for EMI purposes.
4. Mounting hole M1 is safety ground connection.
5. Specifications are for convection rating at factory settings at 115 Vac input, 25°C unless otherwise stated.
6. Warranty: 2 year
7. Weight: 0.5 lb/0.23 kg

Power Derating Curve

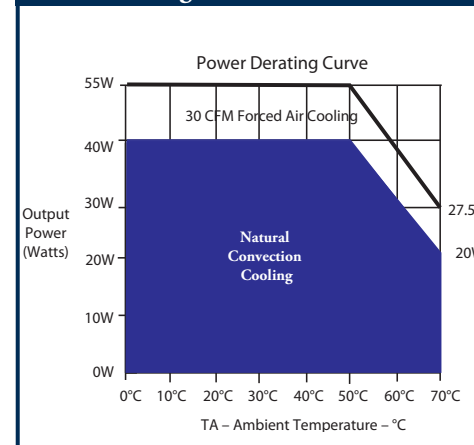

Phone: (800) 377-4384
Email: tech@solahd.com
www.solahd.com

SOLAHD GLT50 Series, GLT50-M Series Installation & Operating Instructions

Installation & Safety

To comply with the published safety standards, the following must be observed when using this power supply:

1. Maximum ambient temperature for the power supply must not exceed 50°C.
2. When installing the power supply in the end-use equipment, special attention is required to ensure safety compliance with the following safety standards: UL60950-1, EN60950-1, IEC60950-1, and CSA22.2 No. 60950-1-03 for GLT52, GLT53, and GLT54; UL60601-1, EN60601-1, IEC60601-1, and CSA22.2 No. 60601-1-M90 for GLT52-M, GLT53-M, and GLT54-M. The safety requirements include creepage distances, clearances, and distance through insulation between primary wiring and earth or secondary (SELV) wiring.
3. This power supply is approved and certified for the rated voltage range of 100 V ac to 240 V ac.
4. The maximum output power of the supply must not exceed the rating indicated in the specification sheet.
5. The disconnection from the line must be in the end system.
6. The internal fuse should only be replaced with a T2.5AL, 250 V ac, type 392 manufactured by Wickmann.

NOTE: The power supply has a fuse on the neutral line for GLT52-M, GLT53-M, and GLT54-M.
7. GLT52-M, GLT53-M, and GLT54-M have no patient applied part.
8. This equipment is considered Class I according to protection against electric shock.
9. This power supply is **CE** marked following the provisions of the Low Voltage Directive, 2006/95/EC.

For technical assistance, contact SolaHD Technical Support at (800) 377-4384 or send an e-mail to tech@solahd.com. Please visit our Web site at www.solahd.com for additional product information and specification sheets.

Output Ratings

Model	Output Voltage (V)	Convection Cooling	
		Max. Output Current (A)	Max. Output Power (W)
GLT52 (-M)	+5	8.0	55
	+12	3.0	
	-12	0.5	
GLT53 (-M)	+5	8.0	
	+15	2.4	
	-15	0.5	
GLT54 (-M)	+5	8.0	
	+24	1.5	
	+12	0.5	

Connector PIN Designation

Input Connector	PIN	GLT52 (-M)	GLT53 (-M)	GLT54 (-M)
SK1	1	Neutral		
	3	Line		
Output Connector	PIN	GLT52 (-M)	GLT53 (-M)	GLT54 (-M)
SK2	1	+5 V		
	2	+5 V		
	3	Common		
	4	Common		
	5	-12 V	-15 V	+12 V
	6	+12 V	+15 V	+24 V

SOLAHD GLT52, GLT52-M Installation & Operating Instructions

Mechanical Outline & Dimensions

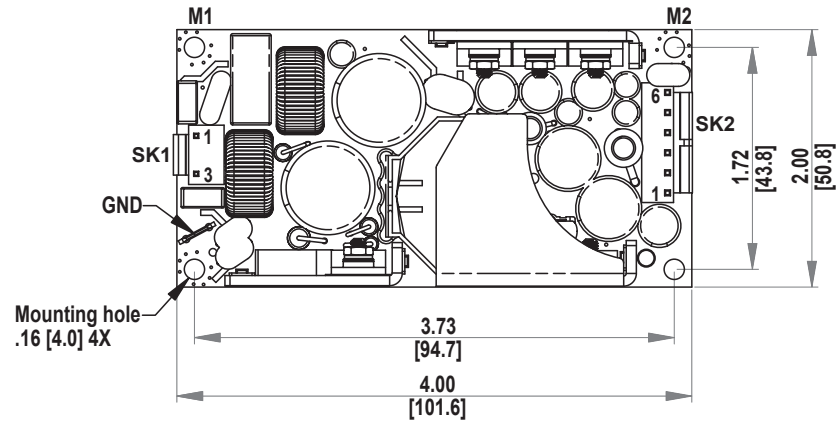

Top View

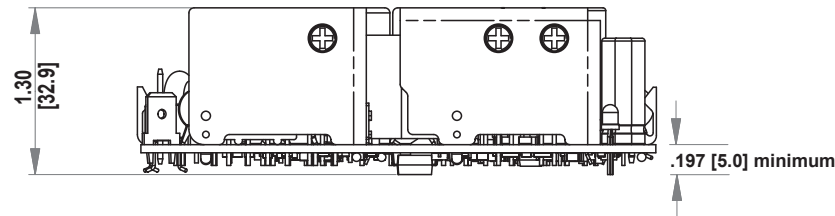

Side View

All dimensions are in inches [mm].
Maximum screw diameter is .22" [5.6 mm].
Mounting holes M1 and M2 should be grounded for EMI purposes. Mounting hole M1 is an earth ground connection.
CAUTION! Do not accidentally connect the ac connector to the dc output.

Safety ground leakage current	<0.5 mA @ 50/60 Hz, 264 Vac input; GLT50-M: <275µA @ 50/60 Hz, 264 Vac input
Output	
Maximum power	55 W convection
Hold-up time	10/20 ms 115/230 Vac input line
Overload protection	Short circuit protection on all outputs. Case overload protected @ 110-160% of normal rating
Overvoltage protection	30-50% above nominal output
Minimum Load	0.5 A for first output, 0.1 A for second output

Environmental Specifications

Operating temperature	0° to 50°C ambient. Derate each output 2.5% per degree from 50° to 70°C. -20°C start up.
Storage temperature	-40°C to 85°C
Electromagnetic susceptibility	Designed to meet EN61000-4; -2, -3, -4, -5, -6, -8, -11 Level 3
Humidity	Operating; non-condensing 10% to 95% RH
Vibration	IEC68-2-6 to the levels of IEC721-3-2
MTBF demonstrated	> 550,000 hours at full load and 25°C ambient conditions

Mating Connectors

AC Input	Molex 09-50-8031 (USA); 09-91-0300 (UK) PINS: 08-52-0113
DC Outputs	Molex 09-50-8061 (USA); 09-91-0600 (UK) PINS: 08-52-0113

Connector Kit #70-841-006, includes all of the above

1. Specifications subject to change without notice.
2. All dimensions in inches (mm), tolerance is ±0.02" (±0.5mm).
3. Mounting holes M1 and M2 should be grounded for EMI purposes.
4. Mounting hole M1 is safety ground connection.
5. Specifications are for convection rating at factory settings at 115 Vac input, 25°C unless otherwise stated.
6. Warranty: 2 year
7. Weight: 0.45 lb/0.20 kg



Phone: (800) 377-4384
Email: tech@solahd.com
www.solahd.com

SOLAHD GLT53, GLT53-M Installation & Operating Instructions

To comply with the published safety standards, the following must be observed when using this power supply:

- Maximum ambient temperature for the power supply must not exceed 50°C.
 - When installing the power supply in the end-use equipment, special attention is required to ensure safety compliance with the following safety standards: UL60950-1, EN60950-1, IEC60950-1, and CSA22.2 No. 60950-1-03 for GLT53; UL60601-1, EN60601-1, IEC60601-1, and CSA22.2 No. 60601-1-M90 for GLT53-M. The safety requirements include creepage distances, clearances, and distance through insulation between primary wiring and earth or secondary (SELV) wiring.
 - This power supply is approved and certified for the rated voltage range of 100 V ac to 240 V ac.
 - The maximum output power of the supply must not exceed the rating indicated in the specification sheet.
 - The disconnection from the line must be in the end system.
 - The internal fuse should only be replaced with a T2.5AL, 250 V ac, type 392 manufactured by Wickmann.
- NOTE:** The power supply has a fuse on the neutral line for GLT53-M.
- GLT53-M has no patient applied part.
 - This equipment is considered Class I according to protection against electric shock.
 - This power supply is **CE** marked following the provisions of the Low Voltage Directive, 2006/95/EC.
 - For technical assistance, contact SolaHD Technical Support at (800) 377-4384 or send an e-mail to tech@solahd.com. Please visit our Web site at www.solahd.com for additional product information and specification sheets.

Output Ratings

Output Voltage (V)	Convection Cooling	
	Max. Output Current (A)	Max. Output Power (W)
+5	8.0	55
+15	2.4	
-15	0.5	

Connector PIN Designation

Input Connector	PIN	Designation
SK1	1	Neutral
	3	Line
Output Connector	PIN	Designation
SK2	1	+5 V
	2	+5 V
	3	Common
	4	Common
	5	-15
	6	+15

GLT53/53-M are commercial designations of model numbers LPT53/53-M respectively.
©2009 EGS Electrical Group. All rights reserved. Specifications subject to change without notice.

Mechanical Outline & Dimensions

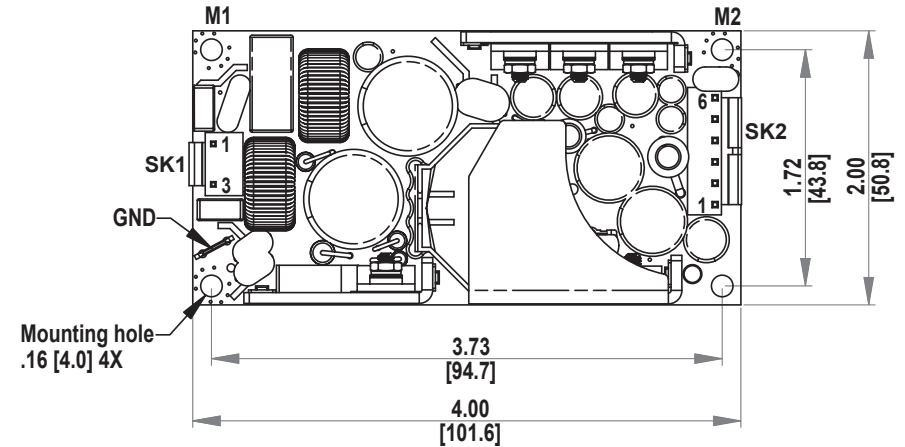

Top View

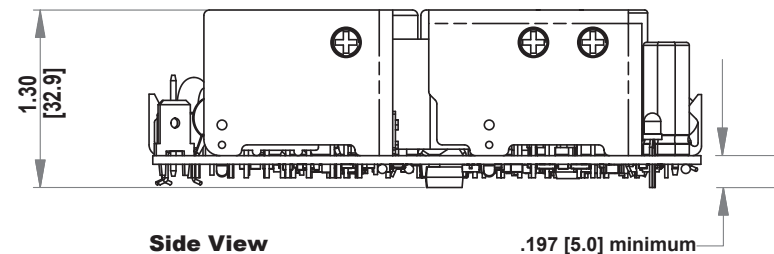

Side View

All dimensions are in inches [mm].

Maximum screw diameter is $.22$ " [5.6 mm].

Mounting holes M1 and M2 should be grounded for EMI purposes. Mounting hole M1 is an earth ground connection.

CAUTION! Do not accidentally connect the ac connector to the dc output.

Safety ground leakage current	<0.5 mA @ 50/60 Hz, 264 Vac input; GLT50-M: <275µA @ 50/60 Hz, 264 Vac input
Output	
Maximum power	55 W convection
Hold-up time	10/20 ms 115/230 Vac input line
Overload protection	Short circuit protection on all outputs. Case overload protected @ 110-160% of normal rating
Overvoltage protection	30-50% above nominal output
Minimum Load	0.5 A for first output, 0.1 A for second output

Environmental Specifications

Operating temperature	0° to 50°C ambient. Derate each output 2.5% per degree from 50° to 70°C. -20°C start up.
Storage temperature	-40°C to 85°C
Electromagnetic susceptibility	Designed to meet EN61000-4; -2, -3, -4, -5, -6, -8, -11 Level 3
Humidity	Operating; non-condensing 10% to 95% RH
Vibration	IEC68-2-6 to the levels of IEC721-3-2
MTBF demonstrated	> 550,000 hours at full load and 25°C ambient conditions

Mating Connectors

AC Input	Molex 09-50-8031 (USA); 09-91-0300 (UK) PINS: 08-52-0113
DC Outputs	Molex 09-50-8061 (USA); 09-91-0600 (UK) PINS: 08-52-0113

Connector Kit #70-841-006, includes all of the above

1. Specifications subject to change without notice.
2. All dimensions in inches (mm), tolerance is ±0.02" (±0.5mm).
3. Mounting holes M1 and M2 should be grounded for EMI purposes.
4. Mounting hole M1 is safety ground connection.
5. Specifications are for convection rating at factory settings at 115 Vac input, 25°C unless otherwise stated.
6. Warranty: 2 year
7. Weight: 0.45 lb/0.20 kg



Phone: (800) 377-4384
Email: tech@solahd.com
www.solahd.com

SOLAHD GLT54, GLT54-M Installation & Operating Instructions

To comply with the published safety standards, the following must be observed when using this power supply:

- Maximum ambient temperature for the power supply must not exceed 50°C.
- When installing the power supply in the end-use equipment, special attention is required to ensure safety compliance with the following safety standards: UL60950-1, EN60950-1, IEC60950-1, and CSA22.2 No. 60950-1-03 for GLT54; UL60601-1, EN60601-1, IEC60601-1, and CSA22.2 No. 60601-1-M90 for GLT54-M. The safety requirements include creepage distances, clearances, and distance through insulation between primary wiring and earth or secondary (SELV) wiring.
- This power supply is approved and certified for the rated voltage range of 100 V ac to 240 V ac.
- The maximum output power of the supply must not exceed the rating indicated in the specification sheet.
- The disconnection from the line must be in the end system.
- The internal fuse should only be replaced with a T2.5AL, 250 V ac, type 392 manufactured by Wickmann.
NOTE: The power supply has a fuse on the neutral line for GLT54-M.
- GLT54-M has no patient applied part.
- This equipment is considered Class I according to protection against electric shock.
- This power supply is **CE** marked following the provisions of the Low Voltage Directive, 2006/95/EC.
- For technical assistance, contact SolaHD Technical Support at (800) 377-4384 or send an e-mail to tech@solahd.com. Please visit our Web site at www.solahd.com for additional product information and specification sheets.

Output Ratings

Output Voltage (V)	Convection Cooling	
	Max. Output Current (A)	Max. Output Power (W)
+5	8.0	55
+24	1.5	
+12	0.5	

Connector PIN Designation

Input Connector	PIN	Designation
SK1	1	Neutral
	3	Line
Output Connector	PIN	Designation
SK2	1	+5 V
	2	+5 V
	3	Common
	4	Common
	5	+12
	6	+24

GLT54/54-M are commercial designations of model numbers LPT54/54-M respectively.
©2009 EGS Electrical Group. All rights reserved. Specifications subject to change without notice.

Mechanical Outline & Dimensions

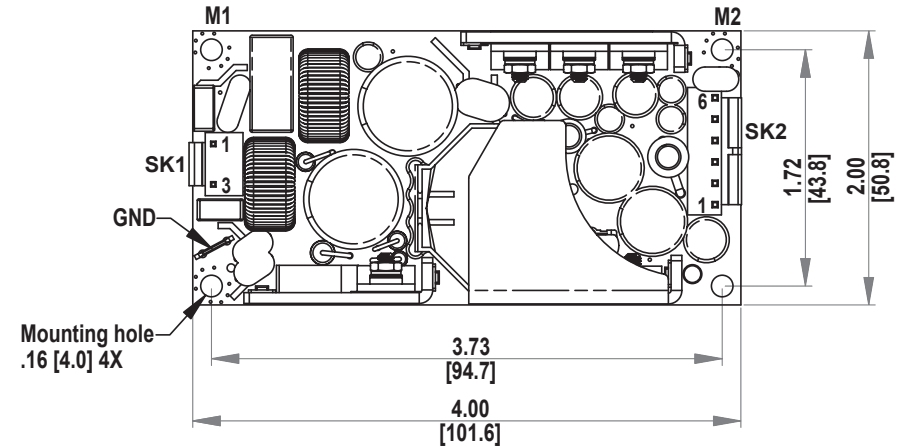

Top View

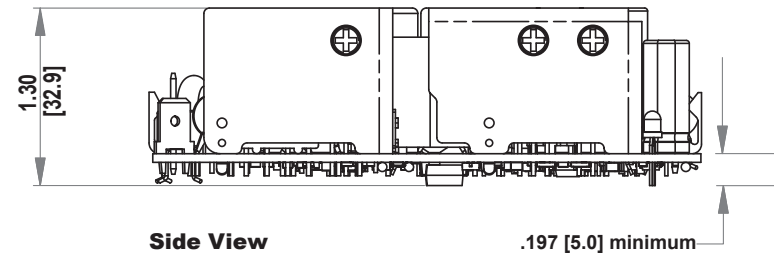

Side View

All dimensions are in inches [mm].

Maximum screw diameter is .22" [5.6 mm].

Mounting holes M1 and M2 should be grounded for EMI purposes.
Mounting hole M1 is an earth ground connection.

CAUTION! Do not accidentally connect the ac connector to the dc output.

Safety ground leakage current	<0.5 mA @ 50/60 Hz, 264 Vac input; GLT50-M: <275µA @ 50/60 Hz, 264 Vac input
Output	
Maximum power	55 W convection
Hold-up time	10/20 ms 115/230 Vac input line
Overload protection	Short circuit protection on all outputs. Case overload protected @ 110-160% of normal rating
Overvoltage protection	30-50% above nominal output
Minimum Load	0.5 A for first output, 0.1 A for second output

Environmental Specifications

Operating temperature	0° to 50°C ambient. Derate each output 2.5% per degree from 50° to 70°C. -20°C start up.
Storage temperature	-40°C to 85°C
Electromagnetic susceptibility	Designed to meet EN61000-4; -2, -3, -4, -5, -6, -8, -11 Level 3
Humidity	Operating; non-condensing 10% to 95% RH
Vibration	IEC68-2-6 to the levels of IEC721-3-2
MTBF demonstrated	> 550,000 hours at full load and 25°C ambient conditions

Mating Connectors

AC Input	Molex 09-50-8031 (USA); 09-91-0300 (UK) PINS: 08-52-0113
DC Outputs	Molex 09-50-8061 (USA); 09-91-0600 (UK) PINS: 08-52-0113

Connector Kit #70-841-006, includes all of the above

1. Specifications subject to change without notice.
2. All dimensions in inches (mm), tolerance is ±0.02" (±0.5mm).
3. Mounting holes M1 and M2 should be grounded for EMI purposes.
4. Mounting hole M1 is safety ground connection.
5. Specifications are for convection rating at factory settings at 115 Vac input, 25°C unless otherwise stated.
6. Warranty: 2 year
7. Weight: 0.45 lb/0.20 kg



Phone: (800) 377-4384
Email: tech@solahd.com
www.solahd.com

To comply with the published safety standards, the following must be observed when using this power supply:

- Maximum ambient temperature for the power supply must not exceed 50°C.
- When installing the power supply in the end-use equipment, special attention is required to ensure safety compliance with the following safety standards: UL60950-1, EN60950-1, IEC60950-1, and CSA22.2 No. 60950-1-03 for GLT62, GLT63, GLT64, and GLT65; UL60601-1, EN60601-1, IEC60601-1, and CSA22.2 No. 60601-1-M90 for GLT62-M and GLT63-M. The safety requirements include creepage distances, clearances, and distance through insulation between primary wiring and earth or secondary (SELV) wiring.
- The power supply's rated input voltage is automatically selected for GLT62, GLT63, and GLT64. Please refer to the specification sheet for the input voltage range. GLT65, GLT62-M, and GLT63-M are approved and certified for the rated voltage range of 100 V ac to 250 V ac and/or 140 V dc to 300 V dc.
- The maximum output power of the supply must not exceed the rating indicated in the specification sheet.
- The earth ground wire must be connected only to the point marked with the earth ground symbol (on the unit).
- The disconnection from the line must be in the end system.
- Hazardous voltages exist in the primary circuits. Disconnect the power supply before servicing.
- When operating with a dc input voltage range, the unit input must be protected by a dc rated fuse in the end-use installation system.
- The internal fuse should only be replaced with a 3.15 A, 250 V ac, type SP0001.1009 manufactured by Schurter AG, type 2163.15 manufactured by Littelfuse, or type S501 manufactured by Cooper.
- This power supply is not suitable for direct contact to the patient.
- This equipment is considered Class I according to protection against electric shock.
- This power supply is **CE** marked following the provisions of the Low Voltage Directive, 2006/95/EC.
- For technical assistance, contact SolaHD Technical Support at (800) 377-4384 or send an e-mail to tech@solahd.com. Please visit our Web site at www.solahd.com for additional product information and specification sheets.

Mechanical Outline

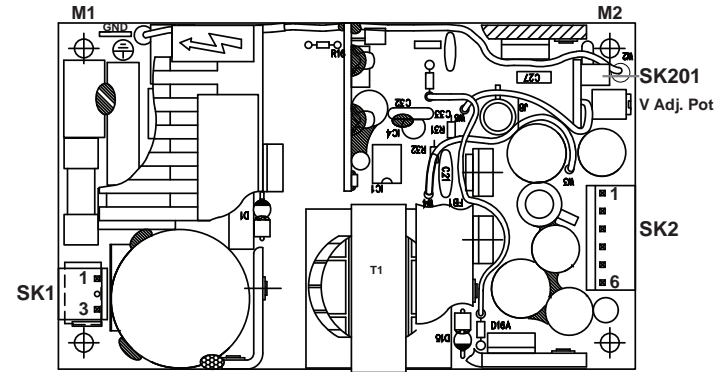

Connector PIN Designation

Input Connector	PIN	GLT62 (-M)	GLT63 (-M)	GLT64	GLT65
SK1	1	Neutral			
	3	Line			
Output Connector	PIN	GLT62 (-M)	GLT63 (-M)	GLT64	GLT65
SK2	1	+12 V	+15 V	+12 V	+24 V
	2	+5 V			
	3				
	4	Common			
	5				
	6	-12 V	-15 V	-5 V	+12 V
SK201	1	+Sense			
	2	-Sense			

NOTE: Mounting holes M1 and M2 should be grounded for EMI purposes. Mounting hole M1 is a safety ground connection.

Output Ratings

Model	Output Voltage (V)	Convection Cooling		30 CFM Forced Air Cooling	
		Max. Output Current (A)	Max. Output Power (W)	Max. Output Current (A)	Max. Output Power (W)
GLT62 (-M)	+5	7.0	60	8.0	80
	+12	3.0		3.5	
	-12	0.7		1.0	
GLT63 (-M)	+5	7.0		8.0	
	+15	2.8		3.3	
	-15	0.7		1.0	
GLT64	+5	7.0	8.0		
	+12	3.0	3.5		
	-5	0.7	1.0		
GLT65	+5	7.0	8.0		
	+24	1.5	2.0		
	+12	0.7	1.0		

Mechanical Dimensions

Bottom View

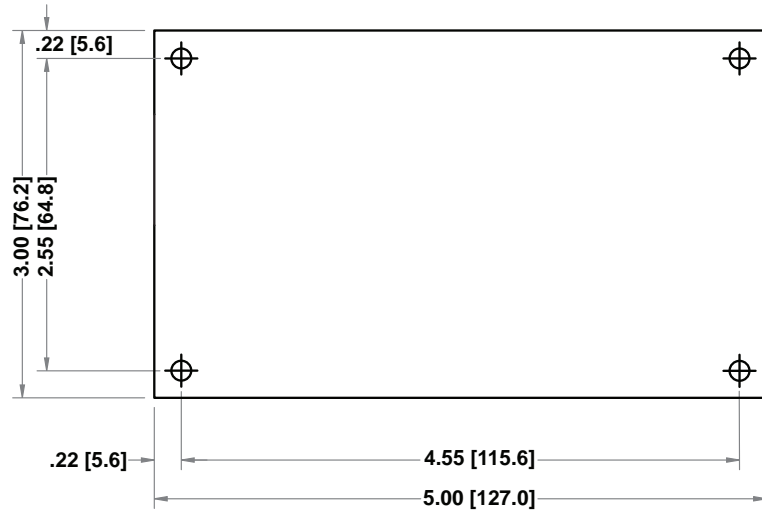

Side View

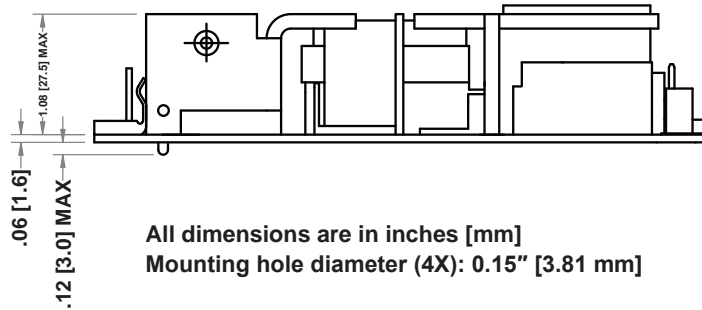

Typical Ventilation Setup

Top View

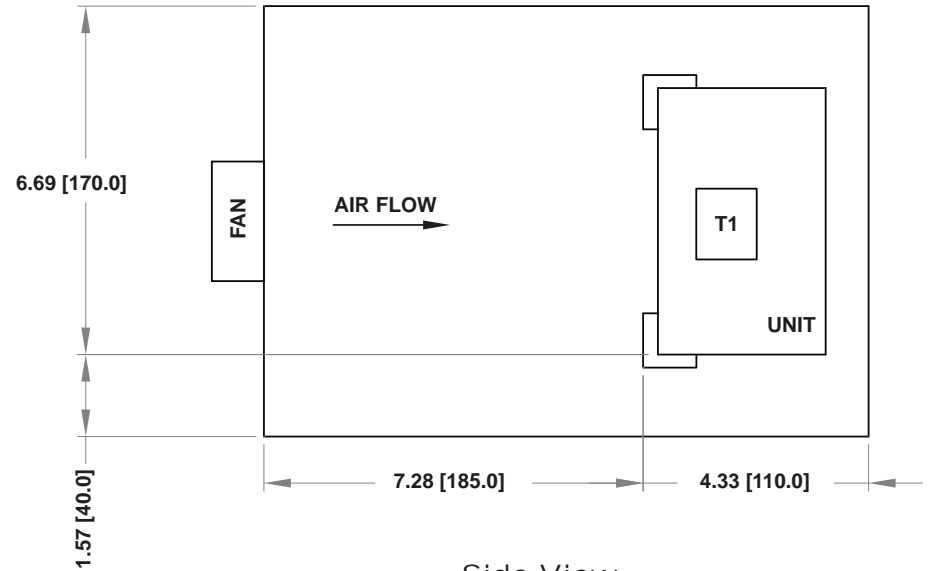

Side View

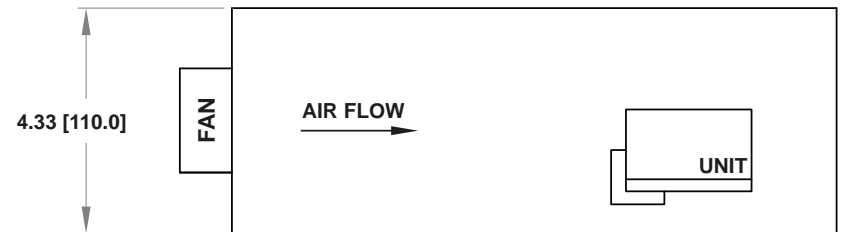

Fan: MINEBEA 3110NL-04W-B30

Fan Input: 12 V dc

NOTE: Dimensions and fan used are for reference only

Safety ground leakage current	<0.5 mA @ 50/60 Hz, 264 Vac input
Output	
Maximum power	60 W convection; 80 W with 30 CFM forced air
Cross regulation	±2% on output 1; ±5% on outputs 2, 3
Adjustment range	-5, 10% min.
Hold-up time	20 ms @ 40 W load, 115 Vac nominal line
Overload protection	Short circuit protection on all outputs. Case overload protected @ 110-145% above peak rating
Overvoltage protection	5.7 to 6.7 Vdc on the main output
Remote sense	Compensates for 0.5 V lead drop minimum, will operate without remote sense connected. Reverse connection protected
Minimum Load	GLT62, 63, 64: 0.7 A for the first output, 0.3 A for second outputs GLT65: 0.7 A for the first output, 0.1 A for second outputs

Environmental Specifications

Operating temperature	0° to 50°C ambient. Derate each output 2.5% per degree from 50° to 70°C, -20°C startup
Storage temperature	-40°C to 85°C
Temperature coefficient	±0.04% per °C
Electromagnetic susceptibility	Designed to meet IEC 801, -2, -3, -4, -5, -6, Level 3
Humidity	Operating; non-condensing 5% to 95%
Vibration	Three orthogonal axes, sweep at 1 oct/min, 5 min. dwell at four major resonances 0.75G peak 5 Hz to 500 Hz, operational
MTBF demonstrated	>550,000 hours at full load and 25°C ambient conditions

Mating Connectors

AC Input	Molex 09-50-8031 (USA) 09-91-0300 (UK); PINS: 08-58-0111
DC Outputs	Molex 09-50-8061 (USA) 09-91-0600 (UK); PINS: 08-52-0113
Remote Sense	Molex 22-01-2025 PINS: 08-52-0113

Connector Kit #70-841-006, includes all of the above

- Specifications subject to change without notice.
- All dimensions in inches (mm), tolerance is ±0.02" (±0.5mm).
- Mounting holes M1 and M2 should be grounded for EMI purposes.
- Mounting hole M1 is safety ground connection.
- Specifications are for convection rating at factory settings at 115 Vac input, 25°C unless otherwise stated.
- Warranty: 2 year
- Weight: 0.75 lb/0.34 kg

Power Derating Curve

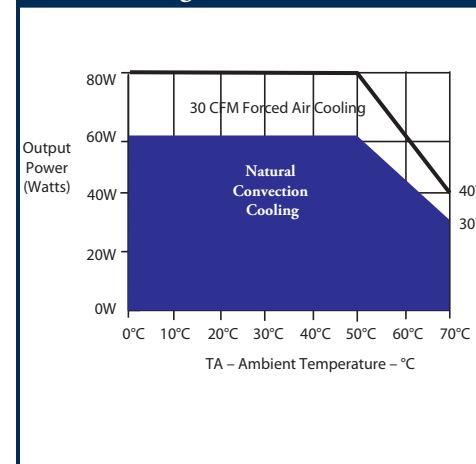

SOLAHD GLX110-C Cover Kit

Designed for the following power supplies: GL110 Series, -B versions only

What's Included

- One cover
- Four M3 x 6mm countersunk screws

Assembly

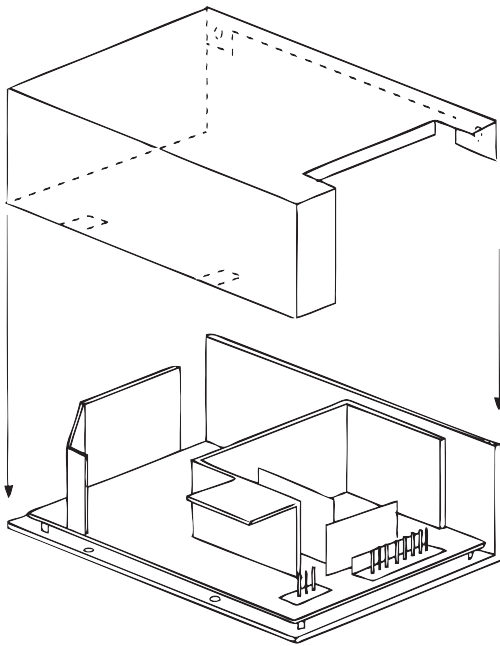

Figure 1: Assembly Drawing

Notes

- All dimensions are in inches [mm].
- Ensure that the relevant safety standards (e.g. EN60950-1) are complied with, in respect to creepage and clearance distances, and distances through insulation.

Overall Dimensions

7.64 in. [194.0 mm] x 4.53 in. [115.0 mm] x 2.44 in. [62.0 mm]

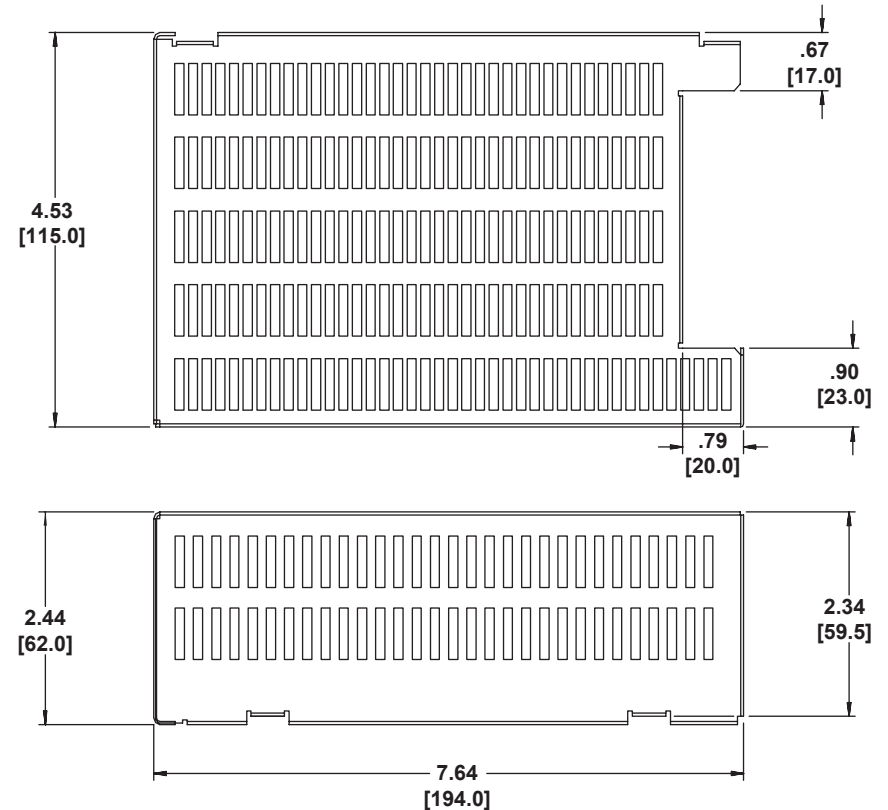

Figure 2: Mechanical Drawing

Technical Support

U.S.: (800) 377-4384 • International: (847) 268-6000

E-mail: tech@solahd.com • Web site: www.solahd.com



SOLAHD GLX120 Cover Enclosure Kit

Designed for the following power supplies: GLS120 Series

What's Included

- One base
- One cover
- One insulator sheet (plastic)
- Four M3 x 6mm Pan head screws (with attached spring washers)
- Four M3 x 6mm countersunk screws
- One M4 nut (for earth ground stud)
- One M4 spring washer (for earth ground stud)
- One M4 star washer (for earth ground stud)

Assembly

1. Place insulator sheet over base standoffs.
2. Place power supply over insulator sheet and align with base standoffs.
NOTE: Ensure the insulator sheet is correctly fitted in the base under the PCB to maintain safety creepage and clearances.
3. Secure power supply to base using the supplied M3 x 6mm Pan head screws (4).
4. Place cover over power supply and align with base countersink holes.
5. Secure cover to base using the supplied M3 x 6mm countersunk screws (4).

Notes

- Ensure base is firmly connected to supply earth via the earth ground stud Ⓧ.
- Ensure that the relevant safety standards (e.g. EN60950-1) are complied with, in respect to creepage and clearance distances, and distances through insulation.
- All dimensions are in inches [mm].

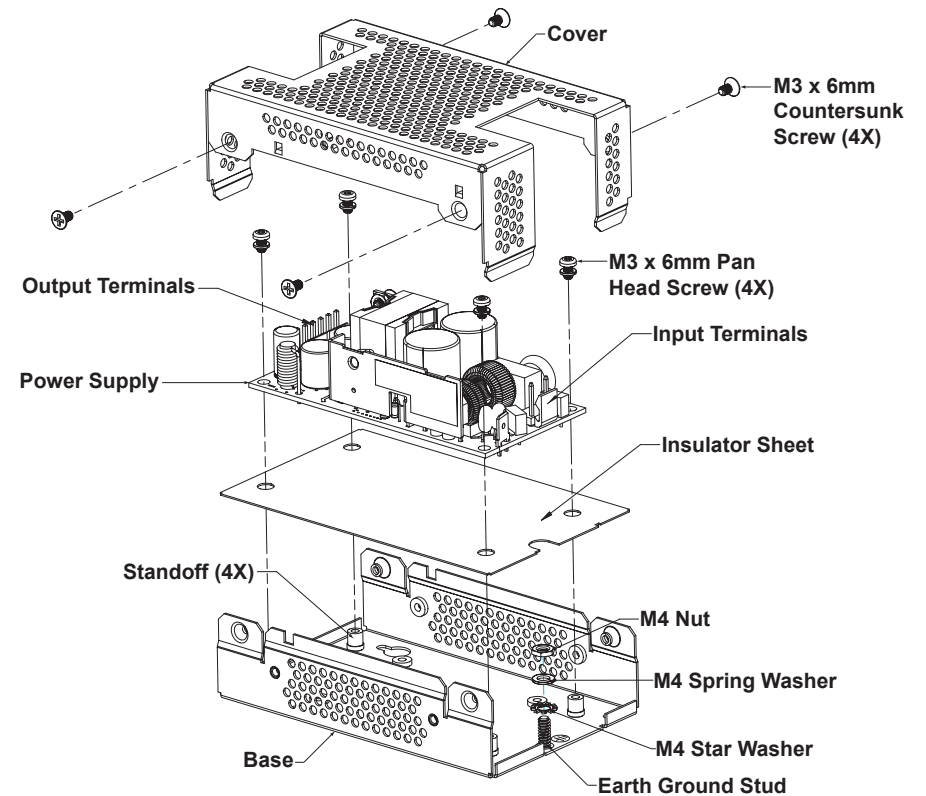

Figure 1: Assembly Drawing

Overall Dimensions

5.95 in. [151.1 mm] x 3.40 in. [86.4 mm] x 1.60 in. [40.6 mm]

Mounting

Two options are available:

1. Bottom mounting using M3 inserts. Maximum screw protrusion is 0.08 in. [2.0 mm].
2. Side mounting using M3 inserts. Maximum screw protrusion is 0.24 in. [6.0 mm].

Technical Support

U.S.: (800) 377-4384 • International: (847) 268-6000

E-mail: tech@solahd.com • Web site: www.solahd.com

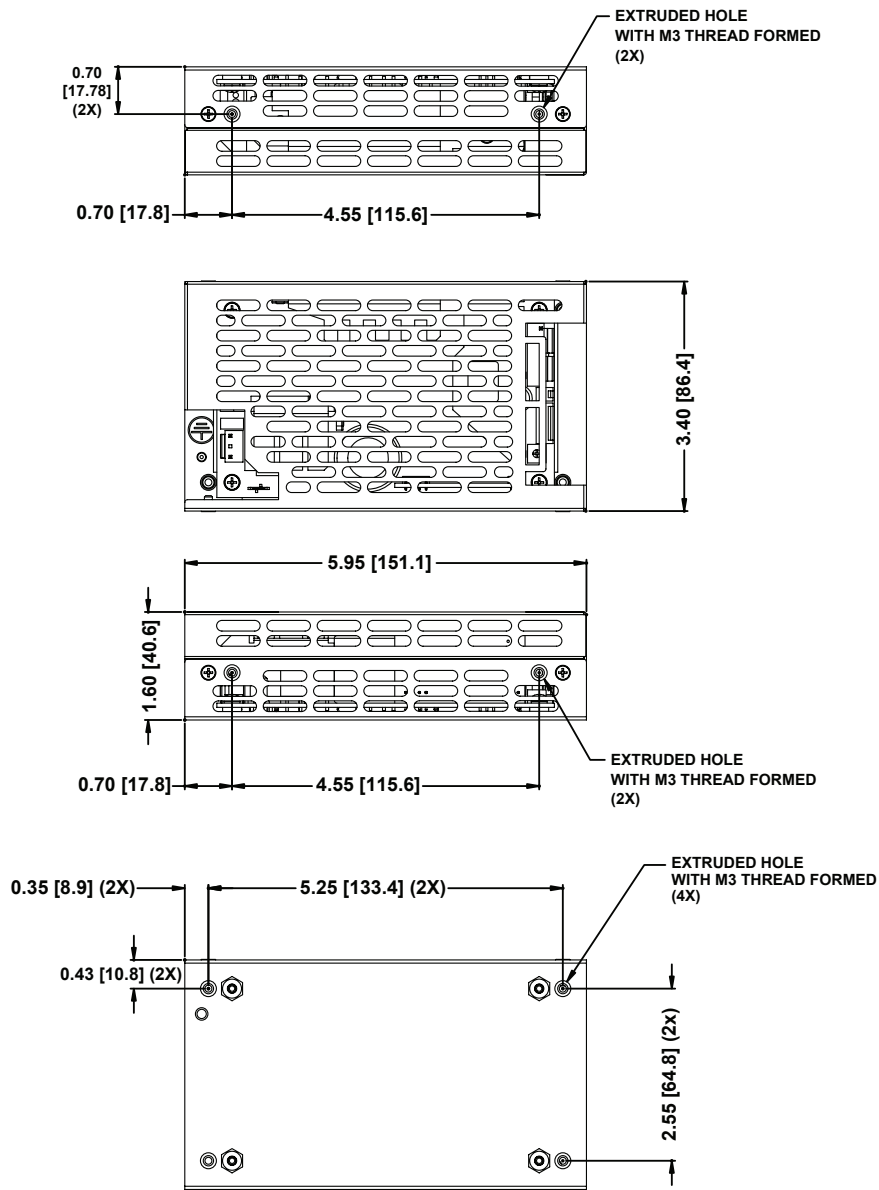

Figure 2: Mechanical Drawing

SOLAHD GLX140-CF Cover Top Fan Kit

Designed for the following power supply: GLQ142

What's Included

- One cover with top fan
- Four M3 x 6mm countersunk screws

Recommended Assembly

1. Attach fan wires to SK5 output connector.

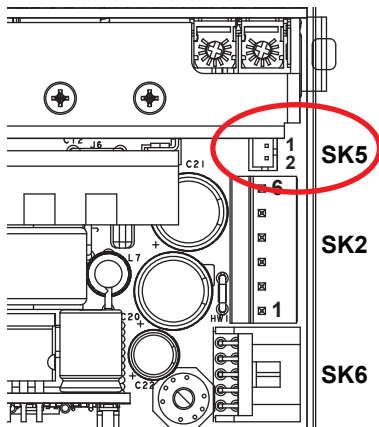

Figure 1: SK5 Output Connector

2. Place cover over power supply and align with base countersink holes.
3. Secure cover to base using the supplied M3 x 6mm countersunk screws (4).

Overall Dimensions

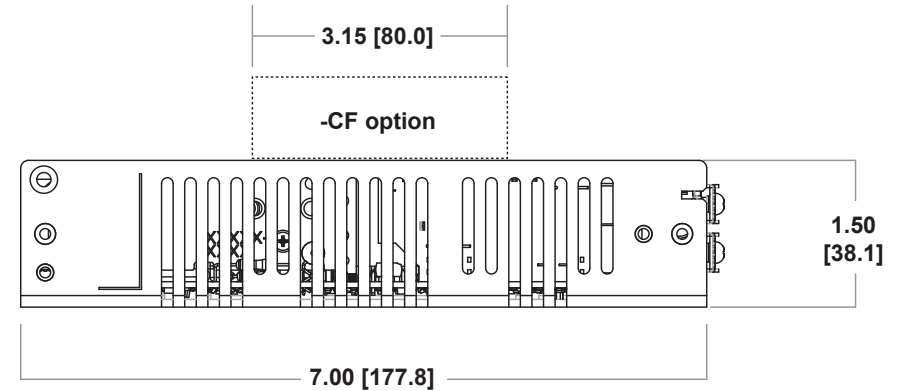

Figure 2: Mechanical Drawing

Notes

- All dimensions are in inches [mm].
- Ensure that the relevant safety standards (e.g. EN60950-1) are complied with, in respect to creepage and clearance distances, and distances through insulation.

Technical Support

U.S.: (800) 377-4384 • International: (847) 268-6000

E-mail: tech@solahd.com • Web site: www.solahd.com



SOLAHD GLX150-C Cover Kit

Designed for the following power supplies: GL150 Series

What's Included

- One cover
- Four M3 x 6mm countersunk screws

Overall Dimensions

8.50 in. [216.0 mm] x 4.25 in. [108.0 mm]

Notes

- All dimensions are in inches [mm].
- Ensure that the relevant safety standards (e.g. EN60950-1) are complied with, in respect to creepage and clearance distances, and distances through insulation.

Technical Support

U.S.: (800) 377-4384 • International: (847) 268-6000

E-mail: tech@solahd.com • Web site: www.solahd.com

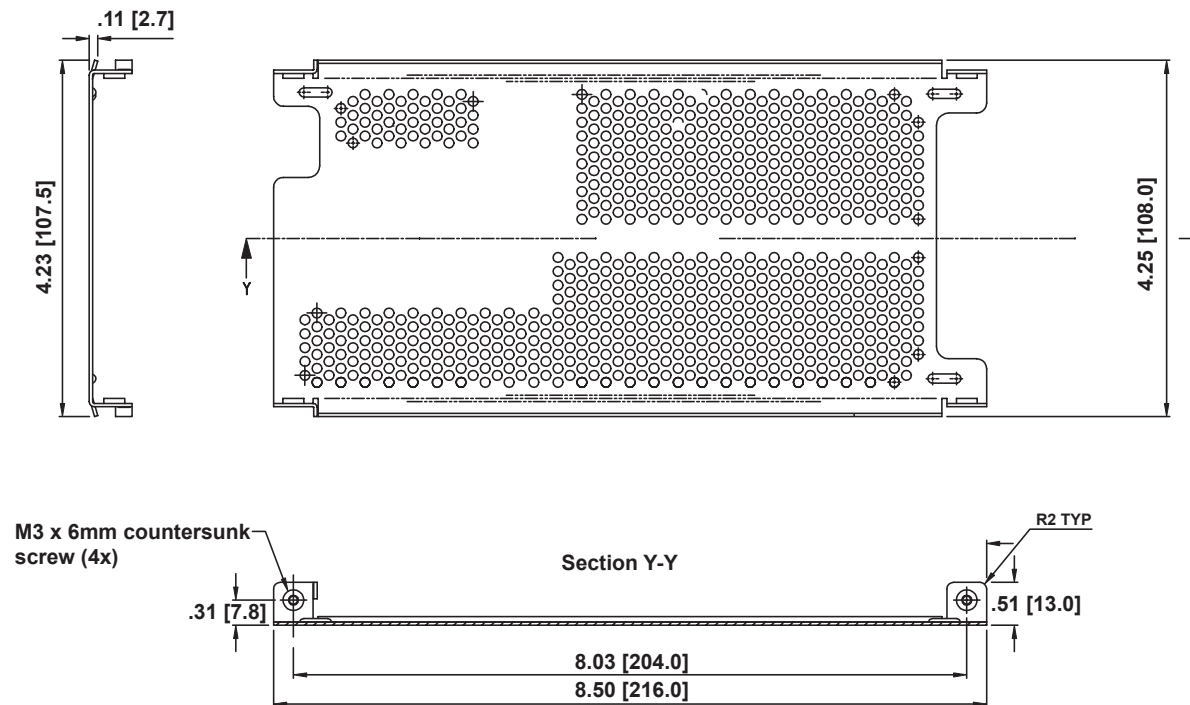

Figure 1: Mechanical Drawing

Designed for the following power supplies: GL200-M Series

What's Included

- One base
- One cover
- One insulator sheet (plastic)
- Four M3 x 6mm Pan head screws (with attached spring washers)
- Four M3 x 6mm countersunk screws
- One M4 nut (for earth ground stud)
- One M4 spring washer (for earth ground stud)
- One M4 star washer (for earth ground stud)

Assembly

1. Place insulator sheet over base standoffs.
2. Place power supply over insulator sheet and align with base standoffs.
NOTE: Ensure the insulator sheet is correctly fitted in the base under the PBC to maintain safety creepage and clearances.
3. Secure power supply to base using the supplied M3 x 6mm Pan head screws (4).
4. Place cover over power supply and align with base countersink holes.
5. Secure cover to base using the supplied M3 x 6mm countersunk screws (4).

Notes

- Ensure base is firmly connected to supply earth via the earth ground stud Ⓧ.
- Ensure that the relevant safety standards (e.g. EN60950-1) are complied with, in respect to creepage and clearance distances, and distances through insulation.
- All dimensions are in inches [mm].

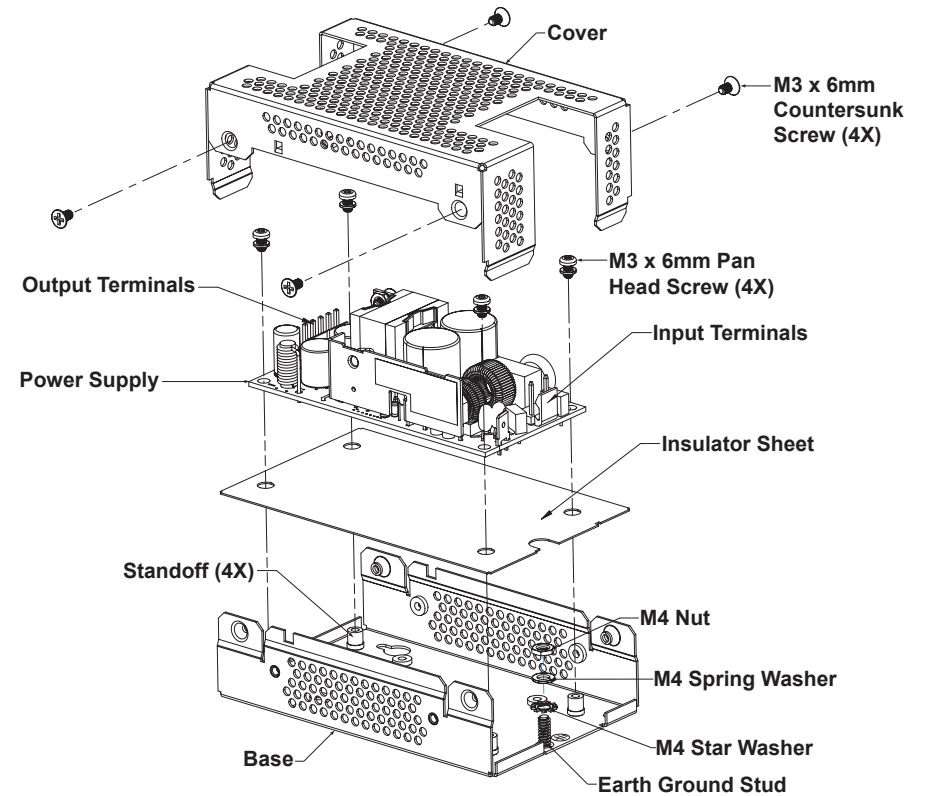

Figure 1: Assembly Drawing

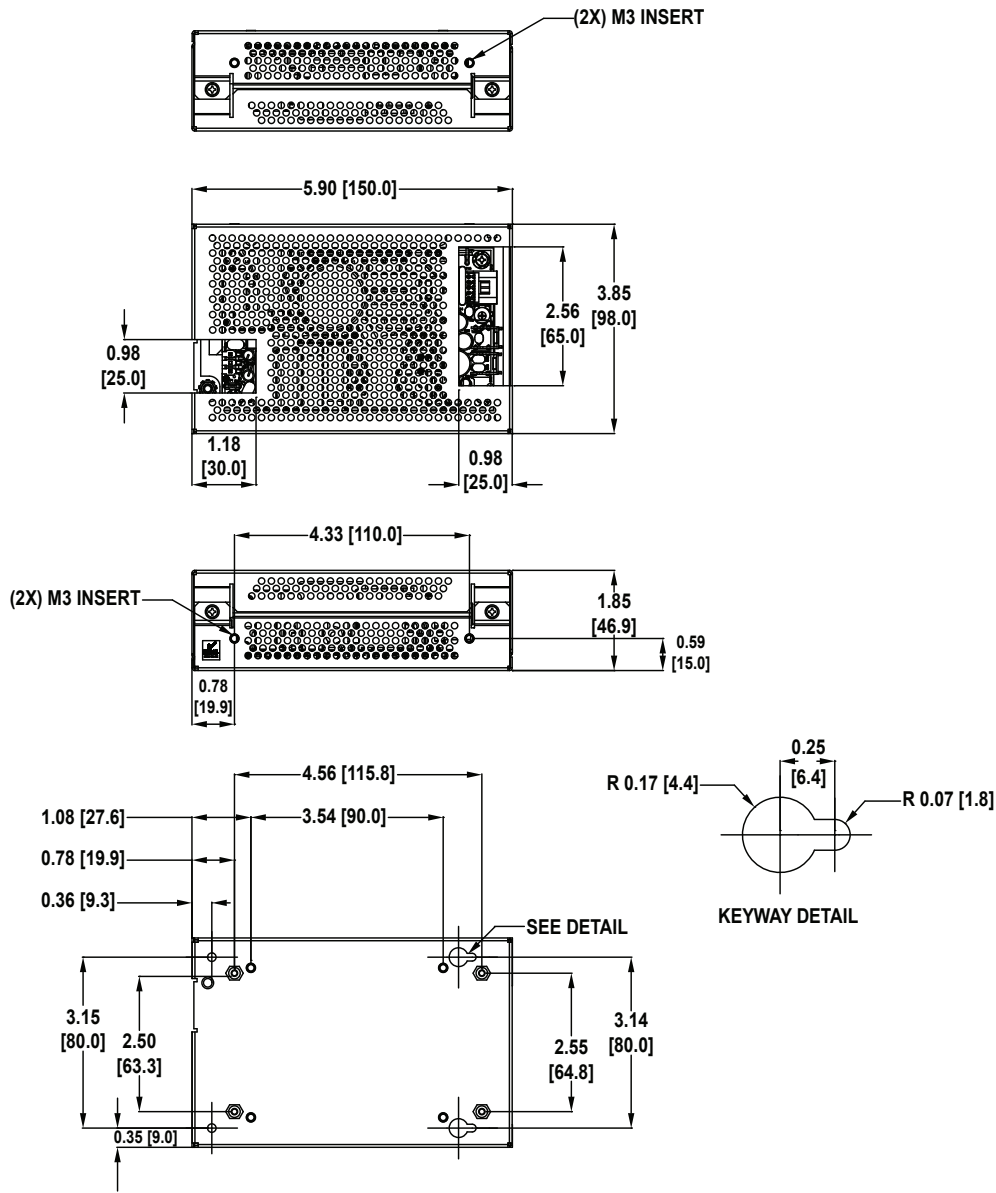

Figure 2: Mechanical Drawing

Overall Dimensions

5.90 in. [150.0 mm] x 3.85 in. [98.0 mm] x 1.85 in. [46.9 mm]

Mounting

Three options are available:

1. Bottom mounting using M3 inserts. Maximum screw protrusion is 0.08 in. [2.0 mm].
2. Side mounting using 4 mm clear holes, plus two keyways.
3. Side mounting using M3 inserts. Maximum screw protrusion is 0.24 in. [6.0 mm].

Technical Support

U.S.: (800) 377-4384 • International: (847) 268-6000

E-mail: tech@solahd.com • Web site: www.solahd.com

SOLAHD GLX250-CEF Cover End Fan Kit

Designed for the following power supplies: GL250 Series

What's Included

- One cover with end fan
- Four M3 x 6mm countersunk screws

Recommended Assembly

1. Remove M3 x 6mm countersunk screws (4) and original cover.
2. Attach the two fan wires to SK4 and SK7 output connectors.

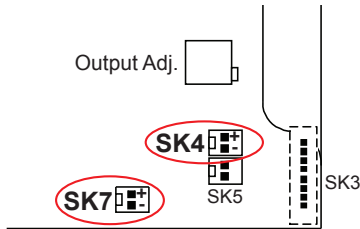

Figure 1: Fan connection

3. Place cover over power supply and align with base countersink holes.
4. Secure cover to base using the supplied M3 x 6mm countersunk screws (4).

Overall Dimensions

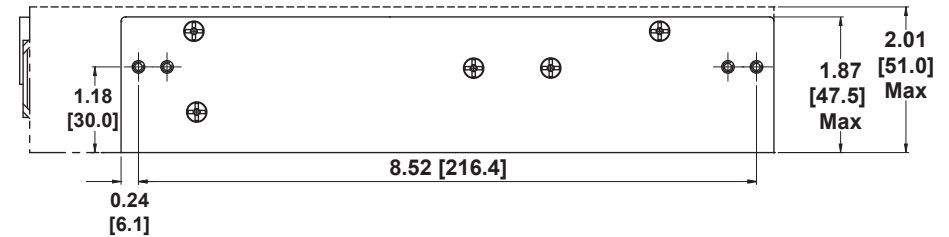

Figure 2: Mechanical Drawing

Notes

- All dimensions are in inches [mm].
- Ensure that the relevant safety standards (e.g. EN60950-1) are complied with in respect to creepage and clearance distances, and distances through insulation.

Technical Support

U.S.: (800) 377-4384 • International: (847) 268-6000

E-mail: tech@solahd.com • Web site: www.solahd.com



SOLAHD GLX250-CF Cover Top Fan Kit

Designed for the following power supplies: GL250 Series and GL350 Series

What's Included

- One cover with top fan
- Four M3 x 6mm countersunk screws

Recommended Assembly

1. Remove M3 x 6mm countersunk screws (4) and original cover.
2. Attach fan wires to SK4 or SK7 output connector for GL250 Series, SK5 or SK6 output connector for GLS350 Series and SK6 output connector for GLQ350 Series. See Figures 1-3.
3. Place cover over power supply and align with base countersink holes.
4. Secure cover to base using the supplied M3 x 6mm countersunk screws (4).

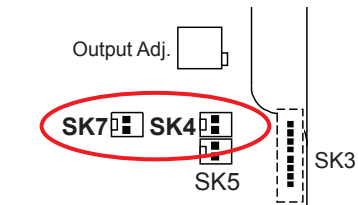

Figure 1: Fan connection for GL250 Series

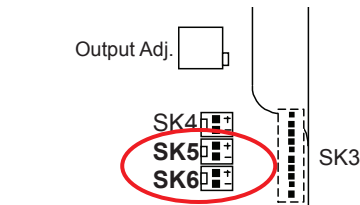

Figure 2: Fan connection for GLS350 Series

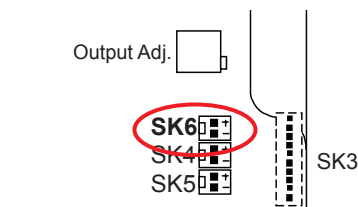

Figure 3: Fan connection for GLQ350 Series

Overall Dimensions

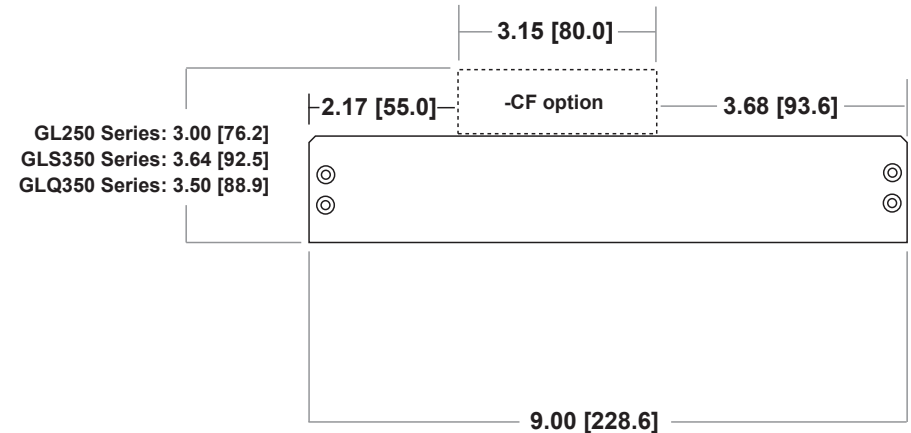

Figure 4: Mechanical Drawing—All Models

Notes

- All dimensions are in inches [mm].
- Ensure that the relevant safety standards (e.g. EN60950-1) are complied with, in respect to creepage and clearance distances, and distances through insulation.

Technical Support

U.S.: (800) 377-4384 • International: (847) 268-6000

E-mail: tech@solahd.com • Web site: www.solahd.com



SOLAHHD GLX40/60 Cover Enclosure Kit

Designed for the following power supplies: GL20 Series, GL40 Series and GL60 Series

What's Included

- One base
- One cover
- One insulator sheet (plastic)
- Four M3 x 6mm Pan head screws (with attached washers)
- Two M3 x 6mm countersunk screws
- One M4 nut (for earth ground stud)
- One M4 spring washer (for earth ground stud)
- One M4 star washer (for earth ground stud)

Assembly

1. Place insulator sheet over base standoffs.
2. Place power supply over insulator sheet and align with base standoffs.
NOTE: Ensure the insulator sheet is correctly fitted in the base under the PBC to maintain safety creepage and clearances.
3. Secure power supply to base using the supplied M3 x 6mm Pan head screws (4).
4. Place cover over power supply and align with base countersink holes.
5. Secure cover to base using the supplied M3 x 6mm countersunk screws (2).

Notes

- Ensure base is firmly connected to supply earth via the earth ground stud \oplus .
- Ensure that the relevant safety standards (e.g. EN60950-1) are complied with, in respect to creepage and clearance distances, and distances through insulation.
- All dimensions are in inches [mm].

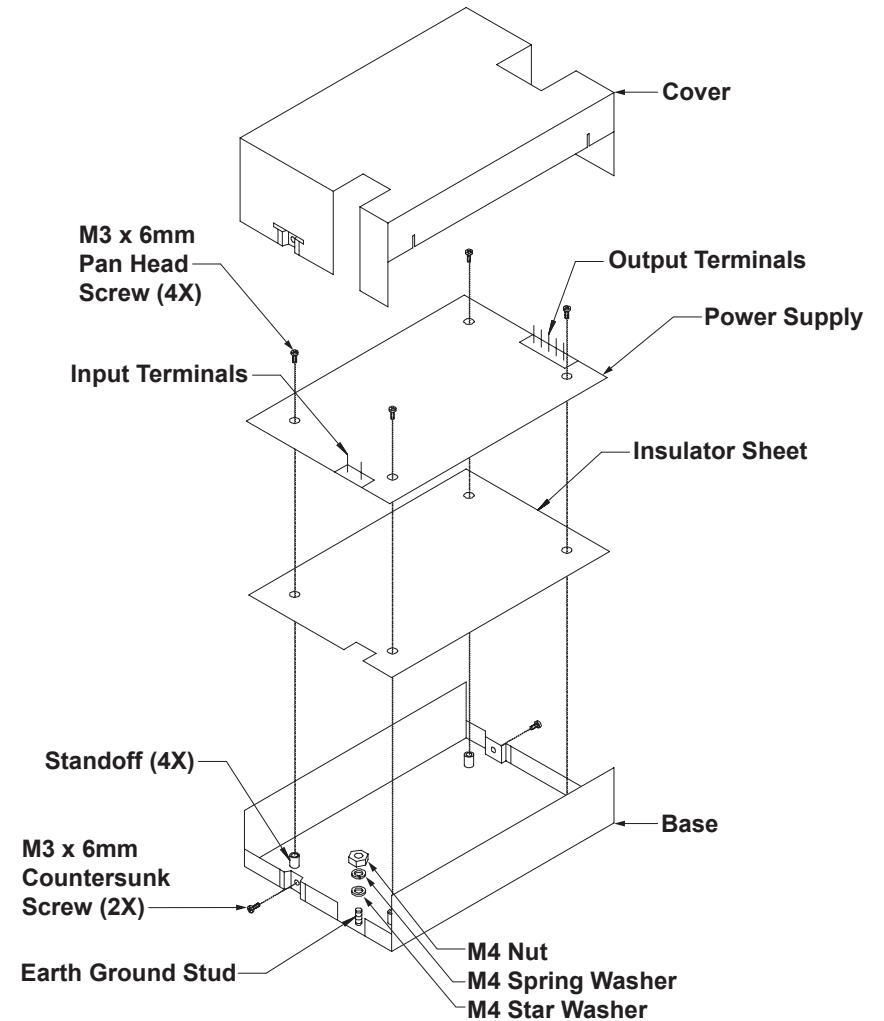

Figure 1: Assembly Drawing

Overall Dimensions

GL20 Series/GL40 Series: 5.90 in. [150.0 mm] x 3.86 in. [98.0 mm] x 1.50 in. [38.0 mm]

GL60 Series: 5.90 in. [150.0 mm] x 3.86 in. [98.0 mm] x 1.97 in. [50.0 mm]

Mounting

Three options are available:

1. Bottom mounting using M3 inserts. Maximum screw protrusion is 0.08 in. [2.0 mm].
2. Side mounting using 4 mm clear holes, plus two keyways.
3. Side mounting using M3 inserts. Maximum screw protrusion is 0.24 in. [6.0 mm].

Technical Support

U.S.: (800) 377-4384 • International: (847) 268-6000

E-mail: tech@solahd.com • Web site: www.solahd.com

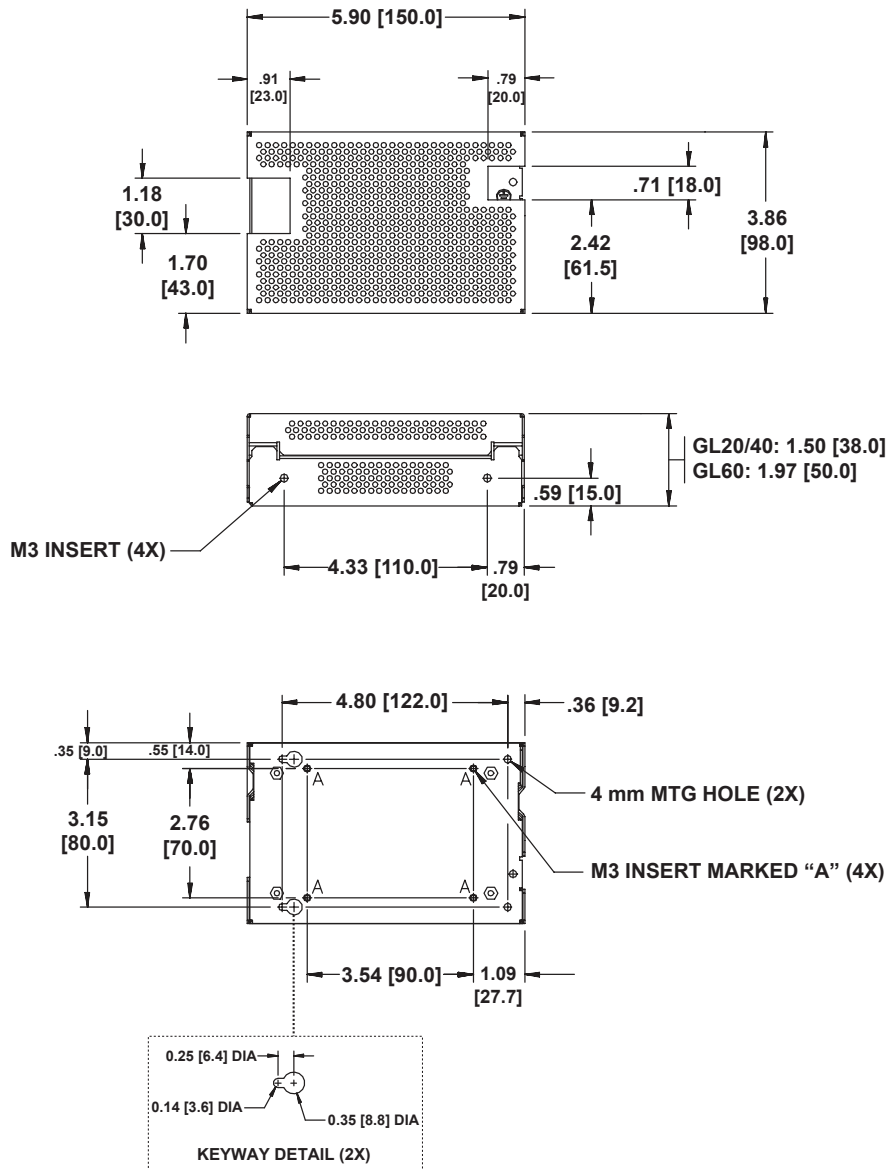

Figure 2: Mechanical Drawing

SOLAHD GLX50 Cover Enclosure Kit

Designed for the following power supplies: GL50 Series and GL100-M Series

What's Included

- One base
- One cover
- One insulator sheet (plastic)
- Four M3 x 6mm Pan head screws (with attached spring washers)
- Four M3 x 6mm countersunk screws
- One M4 nut (for earth ground stud)
- One M4 spring washer (for earth ground stud)
- One M4 star washer (for earth ground stud)

Assembly

1. Place insulator sheet over base standoffs.
2. Place power supply over insulator sheet and align with base standoffs.
NOTE: Ensure the insulator sheet is correctly fitted in the base under the PBC to maintain safety creepage and clearances.
3. Secure power supply to base using the supplied M3 x 6mm Pan head screws (4).
4. Place cover over power supply and align with base countersink holes.
5. Secure cover to base using the supplied M3 x 6mm countersunk screws (4).

Notes

- Ensure base is firmly connected to supply earth via the earth ground stud Ⓧ.
- Ensure that the relevant safety standards (e.g. EN60950-1) are complied with, in respect to creepage and clearance distances, and distances through insulation.
- All dimensions are in inches [mm].

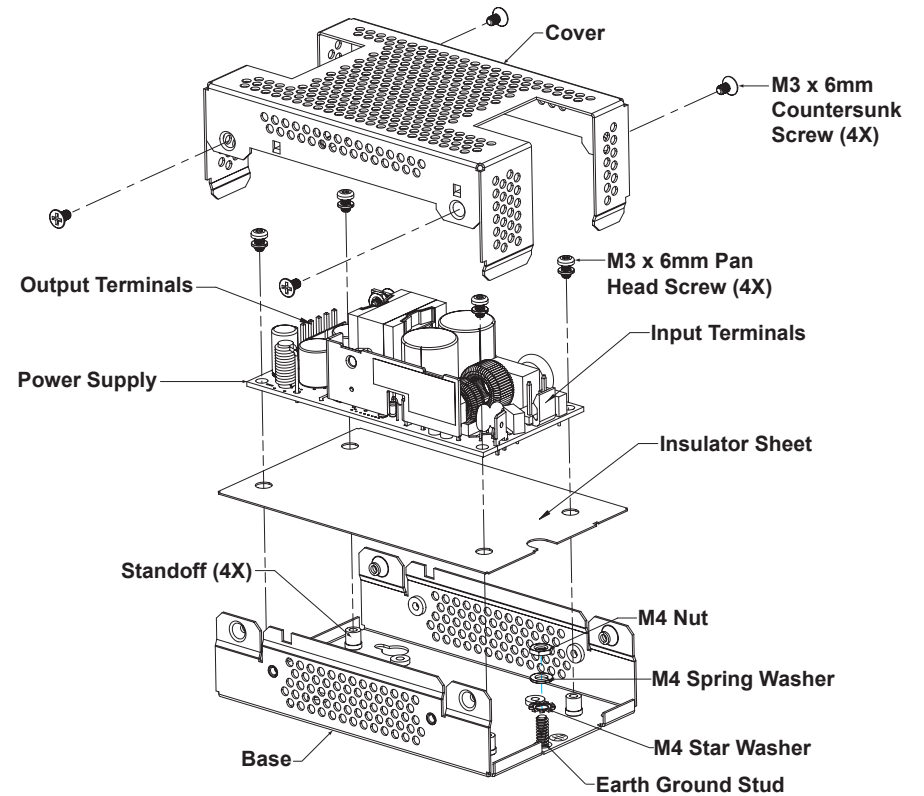

Figure 1: Assembly Drawing

Overall Dimensions

4.69 in. [119.0 mm] x 2.95 in. [74.8 mm] x 1.69 in. [43.0 mm]

Mounting

Three options are available:

1. Bottom mounting using M3 inserts. Maximum screw protrusion is 0.08 in. [2.0 mm].
2. Side mounting using 4 mm clear holes, plus two keyways.
3. Side mounting using M3 inserts. Maximum screw protrusion is 0.24 in. [6.0 mm].

Technical Support

U.S.: (800) 377-4384 • International: (847) 268-6000

E-mail: tech@solahd.com • Web site: www.solahd.com

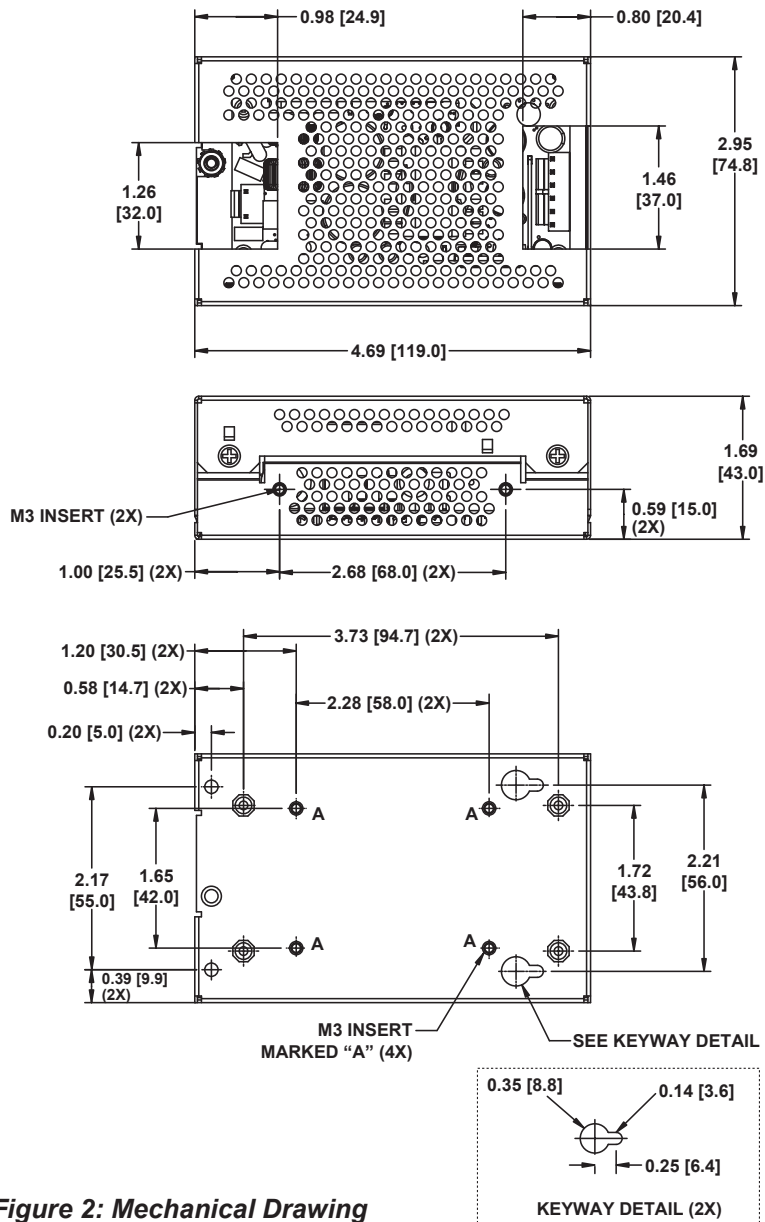

Figure 2: Mechanical Drawing

X-ON Electronics

Largest Supplier of Electrical and Electronic Components

Click to view similar products for [Switching Power Supplies](#) category:

Click to view products by [Sola](#) manufacturer:

Other Similar products are found below :

[70841011](#) [73-551-0005](#) [73-551-0048](#) [PS3E-B12F](#) [PS3E-E12F](#) [AAD600S-4-OP](#) [R22095](#) [KD0204](#) [9021](#) [LDIN100150](#) [LPM000-BBAR-01](#)
[LPX17S-C](#) [EVS57-10R6/R](#) [FP80](#) [FRV7000G](#) [22929](#) [PS3E-F12F](#) [CQM1IA121](#) [40370121900](#) [VI-PU22-EXX](#) [40370121910](#) [LDIN5075](#)
[LPM615-CHAS](#) [LPX140-C](#) [09-160CFG](#) [70841025](#) [VPX3000-CBL-DC](#) [VI-LUL-IU](#) [LPM000-BBAR-05](#) [LPM000-BBAR-08](#) [LPM124-](#)
[OUTA1-48](#) [LPM000-BBAR-07](#) [LPM109-OUTA1-10](#) [LPM616-CHAS](#) [08-30466-1055G](#) [08-30466-2175G](#) [08-30466-2125G](#) [DMB-EWG](#)
[TVQF-1219-18S](#) [6504-226-2101](#) [CQM1IPS01](#) [SP-300-5](#) [CQM1-IPS02](#) [VI-MUL-ES](#) [22829](#) [08-30466-0065G](#) [VI-RU031-EWWX](#) [08-30466-](#)
[0028G](#) [EP3000AC48INZ](#) [VP-C2104853](#)