

Features

- Development Board with Solantro’s SA4011 (IXC) digital power processor
- Preinstalled “starter-code” firmware
- Interface ports for interacting with Solantro’s Helios Test and Control Tool and PuTTY

Development capabilities

- Change register values and parameters on the SA4011 for testing and evaluation purposes
- Download, develop, and test firmware for the SA4011

Development kit

- SA4011(IXC) Development Board with installed firmware
- Helios Test and Control Tool

Description

The Solantro SA4011 Development Board is a PCB on which is mounted a SA4011 IC. An USB port powers the board and used for communications between the SA4011 and a Windows PC. The communication is done with Solantro’s Helios Test and Control Tool (Helios) and PuTTY. Helios is a Windows application which uses a COM port to communicate with the firmware running on the processor through the second UART. The primary purpose is to observe and change program variables and hardware registers as well as loading new firmware. Along with the Solantro Software Development Environment, the SA4011 Development Board provides a platform for developing firmware for the SA4011 to support custom applications. A photograph of the SA4011 Development Board is shown in Figure 1.

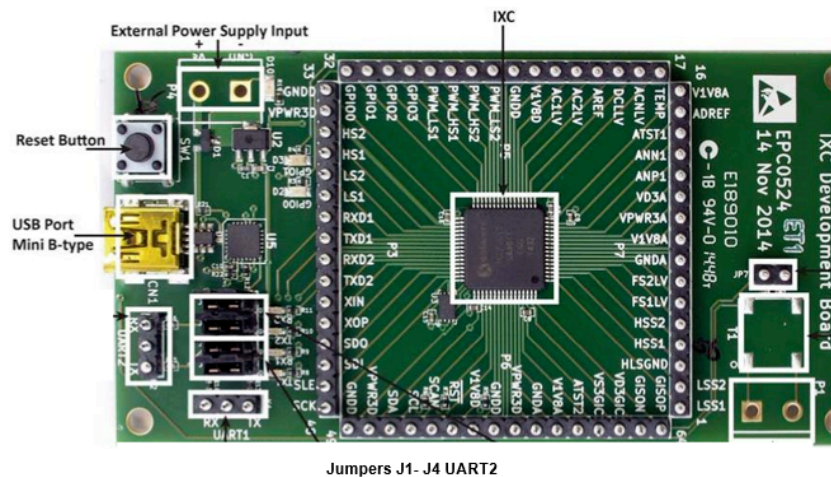

Figure 1 - SA4011 Development Board

PC requirements

- operating system Windows 7 or 10
- USB connection port

Powering the SA4011 Development Board

The SA4011 Development Board is powered via USB cable from a PC to the Mini-B USB port on the Development Board.

Quick start of the SA4011 Development Board

- Step 1** Connect the board to the PC USB port with the USB-A to Mini-B Cable.
- Step 2** Check that the four jumpers JP1 to JP4 are firmly seated.
- Step 3** Install the Solantro Development Environment following DPD1167.
- Step 4** Read SA4011(IXC) datasheet (DPD1036).
- Step 5** Follow the SA4011 (IXC) technical reference guide (DPD1058) to perform examples and become accustomed with SA4011.

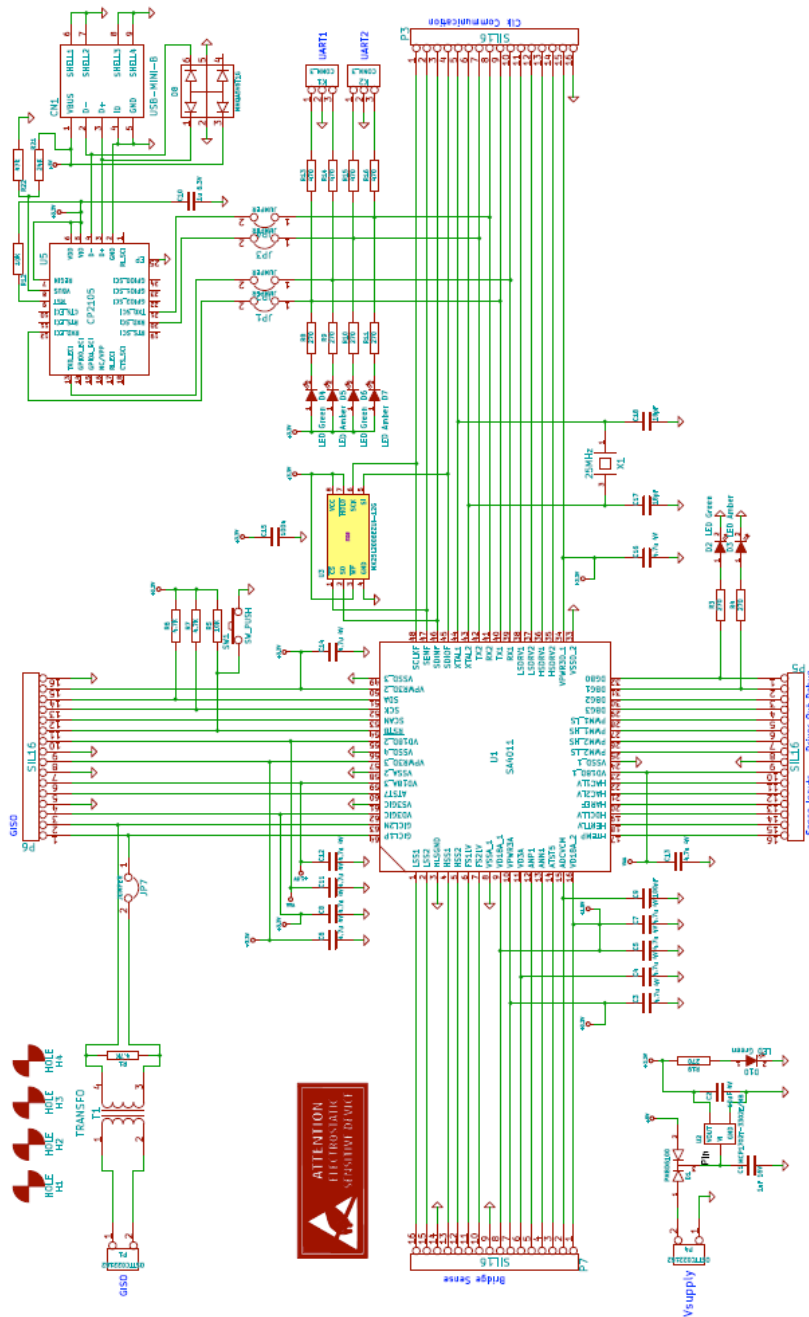

Figure 2 – SA4011 (IXC) Development Board Schematic

For assistance, contact:
Solantero Semiconductor Corp
 Email: info@solantro.com
 Web: www.solantro.com

X-ON Electronics

Largest Supplier of Electrical and Electronic Components

Click to view similar products for [Power Management IC Development Tools](#) category:

Click to view products by [Solantro](#) manufacturer:

Other Similar products are found below :

[EVAL-ADM1168LQEBZ](#) [EVB-EP5348UI](#) [MIC23451-AAAYFL EV](#) [MIC5281YMME EV](#) [DA9063-EVAL](#) [ADP122-3.3-EVALZ](#) [ADP130-0.8-EVALZ](#) [ADP130-1.2-EVALZ](#) [ADP130-1.5-EVALZ](#) [ADP130-1.8-EVALZ](#) [ADP1714-3.3-EVALZ](#) [ADP1716-2.5-EVALZ](#) [ADP1740-1.5-EVALZ](#) [ADP1752-1.5-EVALZ](#) [ADP1828LC-EVALZ](#) [ADP1870-0.3-EVALZ](#) [ADP1871-0.6-EVALZ](#) [ADP1873-0.6-EVALZ](#) [ADP1874-0.3-EVALZ](#) [ADP1882-1.0-EVALZ](#) [ADP199CB-EVALZ](#) [ADP2102-1.25-EVALZ](#) [ADP2102-1.875EVALZ](#) [ADP2102-1.8-EVALZ](#) [ADP2102-2-EVALZ](#) [ADP2102-3-EVALZ](#) [ADP2102-4-EVALZ](#) [ADP2106-1.8-EVALZ](#) [ADP2147CB-110EVALZ](#) [AS3606-DB](#) [BQ24010EVM](#) [BQ24075TEVM](#) [BQ24155EVM](#) [BQ24157EVM-697](#) [BQ24160EVM-742](#) [BQ24296MEVM-655](#) [BQ25010EVM](#) [BQ3055EVM](#) [NCV891330PD50GEVB](#) [ISLUSBI2CKIT1Z](#) [LM2744EVAL](#) [LM2854EVAL](#) [LM3658SD-AEV/NOPB](#) [LM3658SDEV/NOPB](#) [LM3691TL-1.8EV/NOPB](#) [LM4510SDEV/NOPB](#) [LM5033SD-EVAL](#) [LP38512TS-1.8EV](#) [EVAL-ADM1186-1MBZ](#) [EVAL-ADM1186-2MBZ](#)