



»» Features



- 30A general purpose Power Relay.
- SPDM, SPDB, SPDM+DB contact configurations.
- AC & DC coils are both available.
- Optional for anti-rotation tab, tapped core indicator lamp & push-to-test button, flanged covers. (side flange & top flange)
- Complies with RoHS-Directive 2011/65/EU.

»» Type List

Terminal style	Contact form	Designation	Enclosure style				
			Open type	Dust cover	Ears on cover	Antirotation-tab	Ears on top
Quick terminal	1X(SPDM)	-----	737-1X	737-1X-C	737-1X-C1	737-1X-C2	737-1X-C3
	1Y(SPDB)		737-1Y	737-1Y-C	737-1Y-C1	737-1Y-C2	737-1Y-C3
	1Z (SPDM/B)		737-1Z	737-1Z-C	737-1Z-C1	737-1Z-C2	737-1Z-C3
	1X(SPDM)	Lamp	-----	737-1X-C-L	737-1X-C1-L	737-1X-C2-L	737-1X-C3-L
	1Y(SPDB)		-----	737-1Y-C-L	737-1Y-C1-L	737-1Y-C2-L	737-1Y-C3-L
	1Z (SPDM/B)		-----	737-1Z-C-L	737-1Z-C1-L	737-1Z-C2-L	737-1Z-C3-L
	1X(SPDM)	Manual	-----	737-1X-C-M	737-1X-C1-M	737-1X-C2-M	737-1X-C3-M
	1Y(SPDB)		-----	737-1Y-C-M	737-1Y-C1-M	737-1Y-C2-M	737-1Y-C3-M
	1Z (SPDM/B)		-----	737-1Z-C-M	737-1Z-C1-M	737-1Z-C2-M	737-1Z-C3-M
PCB terminal	1X(SPDM)	-----	-----	737-1X-C-T	-----	737-1X-C2-T	737-1X-C3-T
	1Y(SPDB)		-----	737-1Y-C-T	-----	737-1Y-C2-T	737-1Y-C3-T
	1Z (SPDM/B)		-----	737-1Z-C-T	-----	737-1Z-C2-T	737-1Z-C3-T
	1X(SPDM)	Lamp	-----	737-1X-C-LT	-----	737-1X-C2-LT	737-1X-C3-LT
	1Y(SPDB)		-----	737-1Y-C-LT	-----	737-1Y-C2-LT	737-1Y-C3-LT
	1Z (SPDM/B)		-----	737-1Z-C-LT	-----	737-1Z-C2-LT	737-1Z-C3-LT
	1X(SPDM)	Manual	-----	737-1X-C-MT	-----	737-1X-C2-MT	737-1X-C3-MT
	1Y(SPDB)		-----	737-1Y-C-MT	-----	737-1Y-C2-MT	737-1Y-C3-MT
	1Z (SPDM/B)		-----	737-1Z-C-MT	-----	737-1Z-C2-MT	737-1Z-C3-MT

»» Ordering Information

737 - 1X - □ - □ - □ - □
 1 2 3 4 5 6

- | | |
|--------------------------------------|---------------------------|
| 1. 737 -- Basic series designation | 3. Blank -- Standard type |
| | F -- Class F |
| 2. 1X -- Single pole double make | |
| 1Y -- Single pole double break | 4. Blank -- Open type |
| 1Z -- Single pole double make/ break | C -- With cover |

- C1 -- With mounting ears on cover
 C2 -- With accessible mounting hole with anti-rotation tab
 C3 -- Mounting Ears on top of cover

- M -- With manual operator
 T -- Printed circuit board terminals
 L -- Pilot lamp

5. Blank -- No special feature

6. -- Coil voltage (please refer to the coil rating data for the availability)

»» Contact Rating

Resistive load	30A 28VDC, 15A 600VAC, 30A 300VAC
Motor	1HP 120VAC, 1.5HP 200~600VAC
Max. switching current	30A
Max. switching voltage	600VAC
Max. switching capacity	9000VA

»» Coil Rating (DC)

Rated voltage (V)	Rated current ±10 % at 23°C (mA)	Coil resistance ±10 % at 23°C (Ω)	Max. continuous voltage at 75°C	Pick up voltage(Max.) at 23°C	Drop out voltage(Min.) at 23°C	Power consumption at rated voltage
1X 1Y	6	188	110 % of rated voltage	80 % of rated voltage	10 % of rated voltage	approx. 1.2W
	12	100				
	24	51				
	48	27				
	110	11				
	125	12.5				
1Z	6	250				approx. 1.5W
	12	125				
	24	63				
	48	31				
	110	11.5				
	125	13				

»» Coil Rating (AC)

Rated voltage (V)	Coil resistance ±10 % at 23°C (Ω)	Max. continuous voltage at 75°C	Pick up voltage(Max.) at 23°C	Drop out voltage(Min.) at 23°C	Power consumption at rated voltage
6	4.2	110 % of rated voltage	85 % of rated voltage	30 % of rated voltage	approx. 3.0VA
12	18				
24	72				
110	1,580				
120	1,700				
220	5,500				
240	7,200				

»» Specification

Contact material	AgSnO alloy	
Contact resistance ⁽¹⁾	50mΩ Max. (at 1A/6VDC by 4-wire resistance measurement)	
Operate time ⁽¹⁾	25 ms Max.	
Release time ⁽¹⁾	20 ms Max.	
Vibration resistance	Operating extremes	10~55Hz , amplitude 2.0 mm
	Damage limits	10~55Hz , amplitude 2.0 mm
Shock resistance	Operating extremes	10G
	Damage limits	100G
Life expectancy	Mechanical	10,000,000 ops. (frequency 18,000 ops./hr)
	Electrical	100,000 ops. (frequency 360 ops./hr)
Operating ambient temperature	-40~+75 °C (no freezing)	
Weight	Approx. 83 g	

Note : (1) Initial value. Operate and release time excluding contact bounce.

(2) Unless otherwise specified, all tests are under room temperature and humidity.

(3) Consider the heat of PCB is necessary, please check the actual condition of PCB.

(4) Applying no diode to this relay. The life expectancy will be lower when a diode is used. To use a varistor (ZNR) could absorb the coil surge of relay that is recommended.

(5) Do not use the relay exceeding the coil rating, contact rating and life expectancy, or this may cause the risk of overheating.

(6) To assure optimum performance, avoid the relay from dropping, hitting, or other unnecessary shocks.

(7) Do not switch the contacts without any load as the contact resistance may become increased rapidly.

(8) Use suitable harnesses and bus bars according to the current as below :

15A type : Min. 3.0 mm²

30A type : Min. 6.0 mm²

(9) Usage, transport and storage conditions

- 1. Temperature: -40~+75°C
- 2. Humidity: 5 to 85% R.H.
- 3. Pressure: 86 to 106 kPa
- Furthermore, the humidity range varies with the temperature. So, use relays within the range indicated in the graph below.

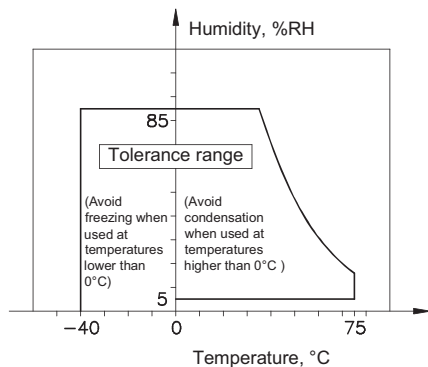

(10) Please contact Song Chuan for the detailed information.

»» Insulation Data

Insulation resistance ⁽¹⁾	1000 MΩ Min. (DC 500V)
Dielectric strength ⁽¹⁾	Between open contact : AC 1000V , 50/60Hz 1 min.
	Between contact and coil : AC 2200V , 50/60Hz 1 min.
	Between live parts & ground : AC 1600V , 50/60Hz 1 min.
Insulation of IEC 61810-1	
Clearance / creepage distances	Between coil to contact : Reinforce, $\geq 3.0\text{mm}$ / $\geq 5.0\text{mm}$
	Between open contact : Functional
Rated insulation voltage	250V
Rated impulse withstand voltage	2500V
Pollution degree	2
Rated voltage	230 / 400V
Overtoltage category	II

Note : (1) Initial value.

»» Safety Approval

Certified	UL / CUL	CSA	TUV
File No.	E88991	1664125	R50044822

»» Safety Approval Rating

UL / CUL	CSA	TUV
30A 28VDC	30A 28VDC	30A 250VAC (for 1X,1Z)
30A 300VAC	30A 300VAC	
15A 600VAC	15A 600VAC	
1HP 120VAC	1HP 120VAC	
1.5HP 200/240/480/600VAC	1.5HP 200~600VAC	

»» Outline Dimensions

◆ 737 C

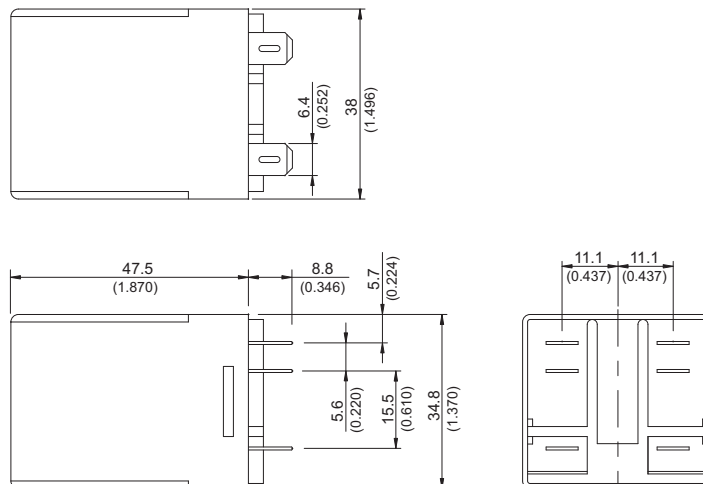

737

◆737 C1

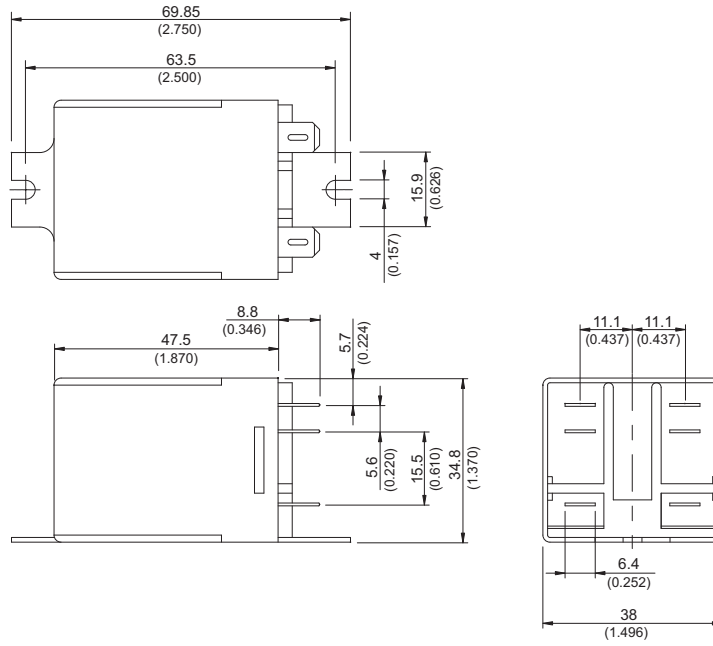

◆737 C2

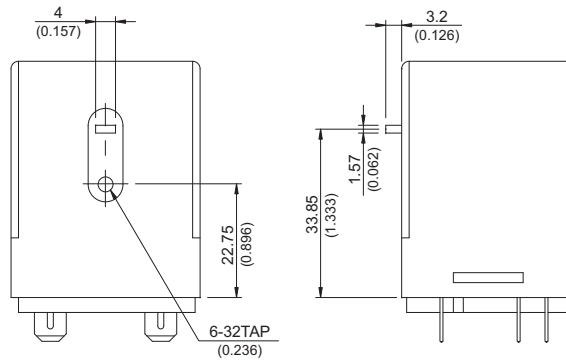

◆737 C3

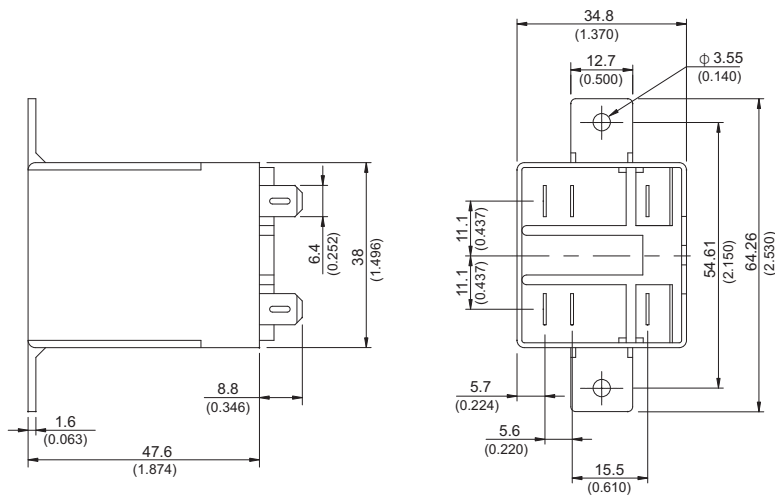

◆ 737 M

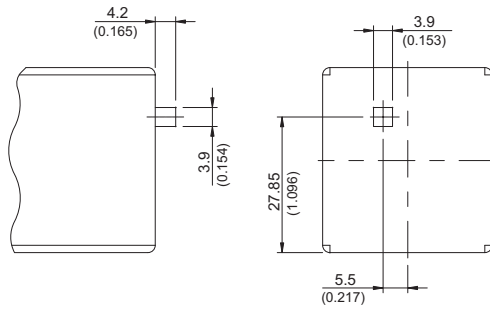

◆ 737 T

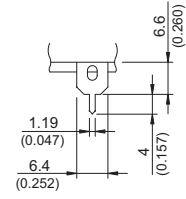

TOLERANCE:
 LESS THAN: 1(0.039) ±0.1(0.004)
 5(0.197) ±0.3(0.012)
 20(0.787) ±0.5(0.020)
 MORE THAN: 20(0.787) ±1(0.039)

»» Wiring Diagram
 BOTTOM VIEW

1X

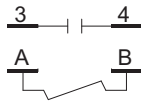

1Y

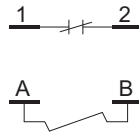

1Z

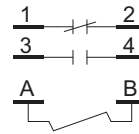

»» PC Board Layout
 BOTTOM VIEW

1X

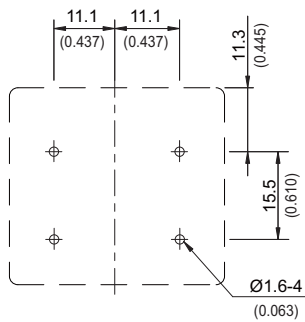

1Y

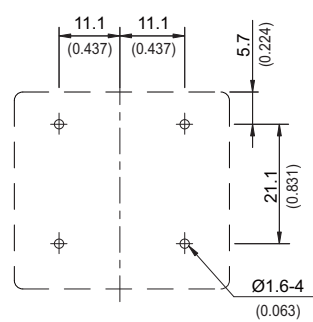

1Z

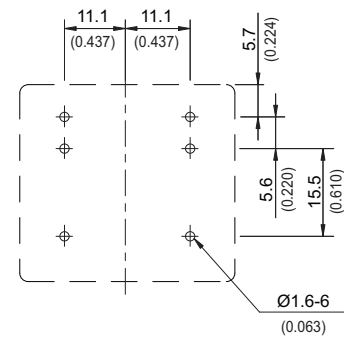

»» Engineering Data

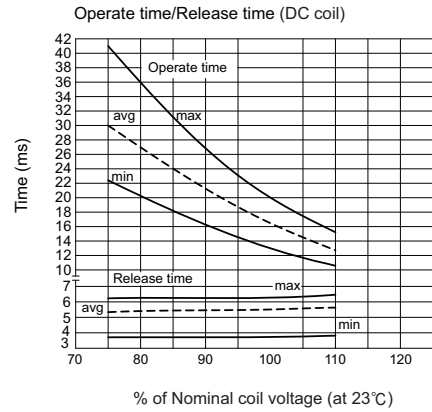
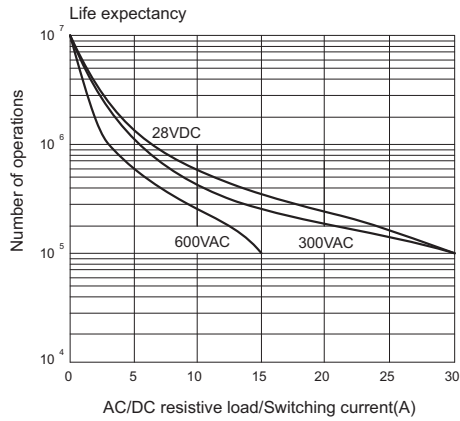
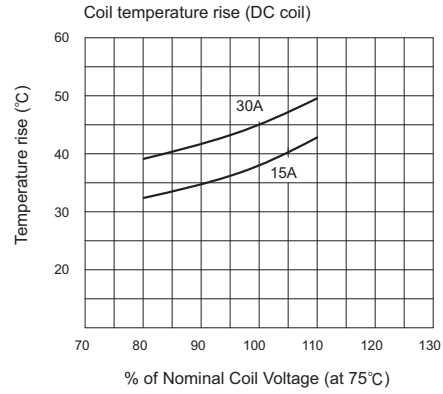
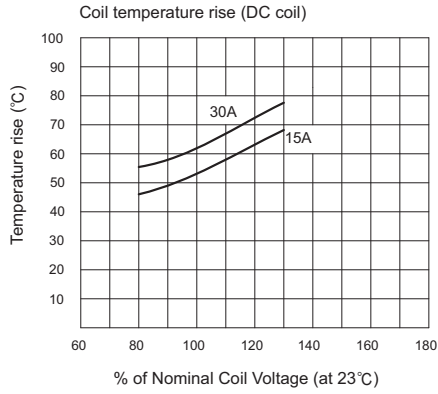

X-ON Electronics

Largest Supplier of Electrical and Electronic Components

Click to view similar products for [General Purpose Relays](#) category:

Click to view products by [Song Chuan](#) manufacturer:

Other Similar products are found below :

[PCN-105D3MH,000](#) [59641F200](#) [LY1SAC110120](#) [5X827E](#) [5X837F](#) [5X840F](#) [5X842F](#) [5X848E](#) [LY2N-AC120](#) [LY2S-AC220/240](#) [LY2-US-AC120](#) [LY3-US-AC120](#) [LY4F-UA-DC12](#) [LY4F-UA-DC24](#) [LY4F-US-AC120](#) [LY4F-US-AC240](#) [LY4F-US-DC24](#) [LY4F-VD-AC110](#) [LYQ20DC12](#) [M115C60](#) [M115N010](#) [M115N0150](#) [6031007G](#) [603-12D](#) [61211T0B4](#) [61212T400](#) [61222Q400](#) [61243B600](#) [61243C500](#) [61243Q400](#) [61311BOA2](#) [61311BOA6](#) [61311BOA8](#) [61311C0A2](#) [61311COA1](#) [61311COA6](#) [61311F0A2](#) [61311QOA1](#) [61311QOA4](#) [61311T0D6](#) [61311TOA6](#) [61311TOA7](#) [61311TOB3](#) [61311TOB4](#) [61311U0A6](#) [61312Q600](#) [61312T400](#) [61312T600](#) [61313U200](#) [61313U400](#)