

深圳市索瑞达电子有限公司

承 认 书

SPECIFICATION FOR APPROVAL

客户名称: 标准
Customer Name : _____

客户料号:
Customer P/N: _____

产品名称: 功率电感
Product Name: _____

索瑞达料号:
Sorede P/N: SNR.6028-系列

制造厂商 Manufacturer	
拟制 Draft	黄小香
审核 Check	符妃团 工程专用章
日期 Date	2018-6-6

客户承认印章 Approval Signet	
日期 Date	

地址: 深圳市观澜镇福城街道新塘村8号源创园陆号A6栋3楼.

Address: 3Rd Floor, Building A6, Yuanchuangyuanlu, No. 8 Xintang Village, Fucheng Street, Guanlan Town, Shenzhen.

电话 Tel: 0755-29803356 传真 Fax: 0755-29803506

电子邮件 E-mail: sorde@vip.163.com

网址 [http:// www.szsorede.com](http://www.szsorede.com)

文件编号 File Number	SRD-WI-3636	版本号 Version Number	A	页码 page	1/3
---------------------	-------------	-----------------------	---	------------	-----

1、外形尺寸 Dimension :

单位Unit: mm

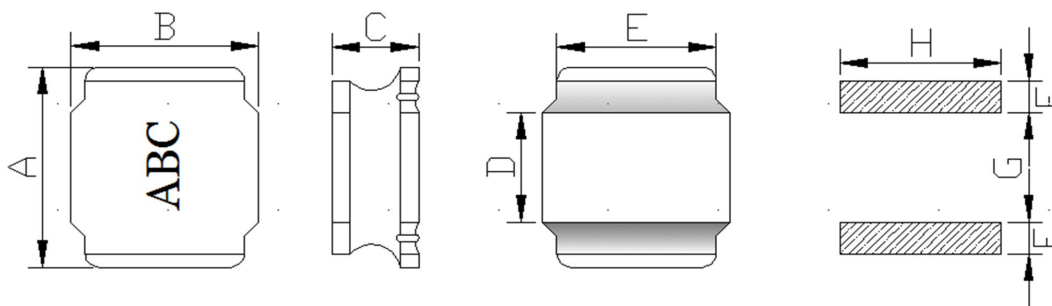

A	6.00±0.3
B	6.00±0.3
C	2.8Max.
D	2.7±0.2
E	4.9Ref
F	2.0Ref
G	2.4Ref
H	5.7Ref

2、产品品名构成 Product Spec. Model

SR 6028T Y D - 2R2 N

a b c d e f

a: 系列名称 Series name

b: 产品尺寸 Product dimensions (A x B x C)

c: 密封方式 Sealing way (L: 冷封 Cold seal Y: 热封 Heat seal)

d: 印字方向 Lettering direction ▶

e: 电感值 Inductance Value

(1R0:1.0uH; 100: 10uH; 101:100uH)

f: 电感公差 Inductance Tolerance (K:10% ; M:20% ; N:30%)

▶ Lettering direction

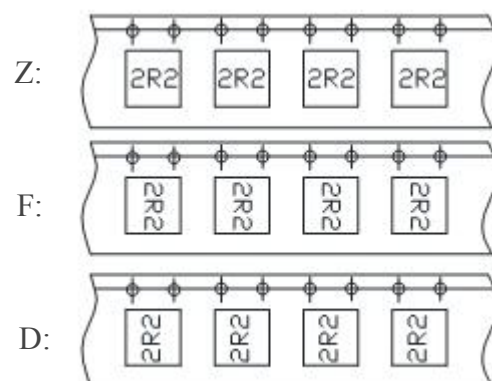

3、结构 Structure

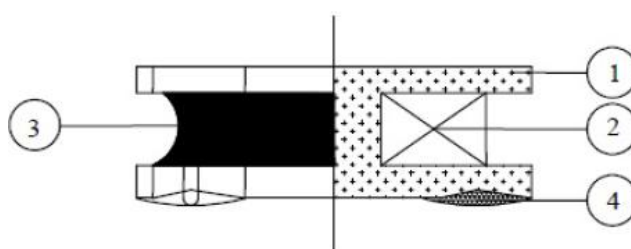

4、材料清单 MATERIAL LIST

NO.	PARTS	MATERIAL	UL FILE NO.	TEMP. CLASS
1	CORE	Ni-Zn CORE OR EQUIVALENT	NA	NA
2	WIRE	POLYURETHANE ENAMELLED COPPER WIRE OR EQUIVALENT	E258243	180°C
3	ADHESIVE	EPOXY RESIN OR EQUIVALENT	NA	NA
4	SOLDER	Sn99.3-Cu0.7 OR EQUIVALENT	NA	NA

*NA:NOT APPLICABLE.

文件编号 File Number	SRD-WI-3636	版本号 Version Number	A	页码 page	2/3
---------------------	-------------	-----------------------	---	------------	-----

5、电性能参数表 Electrical Characteristics List

规格型号 Part NO.	电感量 Tolerance(μ H)	测试频率 Test Freq. (kHz/v)	直流电阻 DC Max (Ω)	饱和电流 Isat (A)	温升电流 Irms (A)
SNR.6028.TYDR68NT00	0.68	100/0.25	0.013	6.90	5.50
SNR.6028.TYD1R0NT00	1.0	100/0.25	0.015	6.70	5.20
SNR.6028.TYD1R5NT00	1.5	100/0.25	0.020	6.00	4.58
SNR.6028.TYD1R6NT00	1.6	100/0.25	0.020	6.00	4.50
SNR.6028.TYD2R2NT00	2.2	100/0.25	0.026	5.10	3.75
SNR.6028.TYD3R3NT00	3.3	100/0.25	0.033	3.63	3.48
SNR.6028.TYD3R6NT00	3.6	100/0.25	0.035	3.30	3.20
SNR.6028.TYD4R7NT00	4.7	100/0.25	0.042	3.00	3.08
SNR.6028.TYD5R6NT00	5.6	100/0.25	0.065	2.80	2.45
SNR.6028.TYD6R0NT00	6.0	100/0.25	0.065	2.80	2.40
SNR.6028.TYD6R8MT00	6.8	100/0.25	0.072	2.60	2.40
SNR.6028.TYD8R2MT00	8.2	100/0.25	0.088	2.40	2.25
SNR.6028.TYD100MT00	10	100/0.25	0.096	2.05	1.95
SNR.6028.TYD120MT00	12	100/0.25	0.114	1.80	1.85
SNR.6028.TYD150MT00	15	100/0.25	0.163	1.75	1.45
SNR.6028.TYD180MT00	18	100/0.25	0.169	1.55	1.45
SNR.6028.TYD220MT00	22	100/0.25	0.182	1.45	1.40
SNR.6028.TYD270MT00	27	100/0.25	0.234	1.40	1.32
SNR.6028.TYD330MT00	33	100/0.25	0.286	1.35	1.22
SNR.6028.TYD470MT00	47	100/0.25	0.364	1.15	1.06
SNR.6028.TYD680MT00	68	100/0.25	0.585	0.95	0.86
SNR.6028.TYD820MT00	82	100/0.25	0.676	0.80	0.70
SNR.6028.TYD101MT00	100	100/0.25	0.845	0.65	0.60
SNR.6028.TYD121MT00	120	100/0.25	0.936	0.56	0.51
SNR.6028.TYD151MT00	150	100/0.25	1.100	0.48	0.42
SNR.6028.TYD201MT00	200	100/0.25	1.870	0.45	0.37
SNR.6028.TYD221MT00	220	100/0.25	1.900	0.40	0.30
SNR.6028.TYD471MT00	470	100/0.25	2.73	0.38	0.28
SNR.6028.TYD102MT00	1000	100/0.25	7.54	0.20	0.23

※公差Tolerance: N:±30%、M:±20%、K:±10%.

※工作温度Operating temperature rang: -40 °C to +125°C (Including Self-heating)

※储存温度Storage temperature rang: -40 °C to +125°C

额定电流: 指使电感量比初始值下降30%或电感器表面温度上升 40°C 的电流值 (参考周围环境温度 25°C)。
The rated DC current is that which cause at 30% inductance reduction from the initial value or inductor surface temperature to rise by 40°C, whichever is smaller (Reference ambient temperature 25°C)。

6、产品包装 Packaging

1) 载带包装示意图 Tape packing diagram

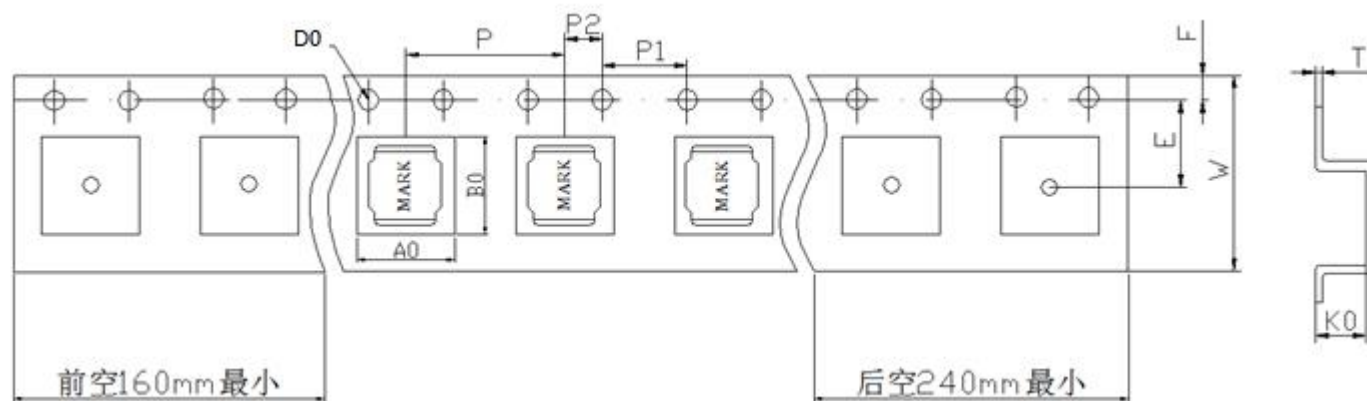

ITEM	W	A0	B0	K0	P	E	F	D0	P0	P2	T
DIM	12.00	6.30	6.30	3.00	8.00	7.50	1.75	1.50	4.00	2.00	0.35
TOLE	±0.3	±0.1	±0.1	±0.1	±0.1	±0.1	±0.1	+0.1	±0.1	±0.1	±0.05

2) 卷盘包装示意图 Tape packing diagram

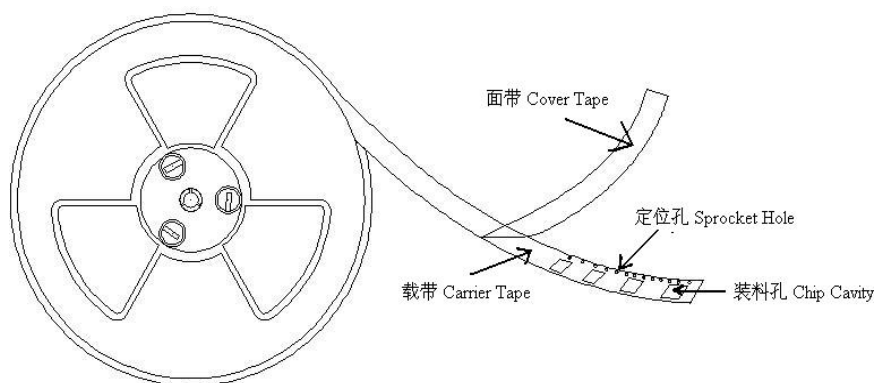

3) 剥离强度要求 Peeling required

① F 力大小: 20~100g;

② 面带剥离角度: 165°~180°。

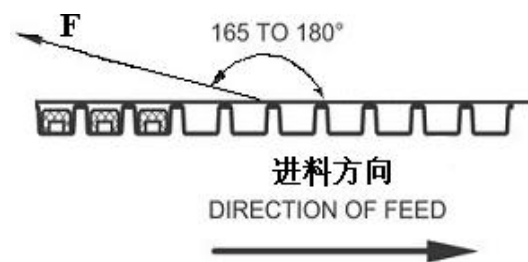

4) 包装数量 Packing quantity

项目	数量 (PCS)	尺寸规格 (mm)
盘	2000	13"
内盒	8000	340mm*340mm*65mm
外箱	16000	360mm*360mm*160mm

X-ON Electronics

Largest Supplier of Electrical and Electronic Components

Click to view similar products for [Fixed Inductors](#) category:

Click to view products by [SOREDE](#) manufacturer:

Other Similar products are found below :

[CR32NP-151KC](#) [CR32NP-180KC](#) [CR32NP-181KC](#) [CR32NP-1R5MC](#) [CR32NP-390KC](#) [CR32NP-3R9MC](#) [CR32NP-680KC](#) [CR32NP-820KC](#) [CR32NP-8R2MC](#) [CR43NP-390KC](#) [CR43NP-560KC](#) [CR43NP-680KC](#) [CR54NP-181KC](#) [CR54NP-470LC](#) [CR54NP-820KC](#) [CR54NP-8R5MC](#) [70F224AI](#) [MGDQ4-00004-P](#) [MHL1ECTTP18NJ](#) [MHQ1005P10NJ](#) [MHQ1005P1N0S](#) [MHQ1005P2N4S](#) [MHQ1005P3N6S](#) [MHQ1005P5N1S](#) [MHQ1005P8N2J](#) [PE-51506NL](#) [PE-53601NL](#) [PE-53602NL](#) [PE-53630NL](#) [PE-53824SNLT](#) [PE-92100NL](#) [PG0434.801NLT](#) [PG0936.113NLT](#) [9220-20](#) [9310-16](#) [PM06-2N7](#) [PM06-39NJ](#) [A01TK](#) [1206CS-471XJ](#) [HC2LP-R47-R](#) [HC2-R47-R](#) [HC3-2R2-R](#) [HCF1305-3R3-R](#) [1206CS-151XG](#) [RCH664NP-140L](#) [RCH664NP-4R7M](#) [RCH8011NP-221L](#) [RCP1317NP-332L](#) [RCP1317NP-391L](#) [RCR1010NP-470M](#)