

## New generation Time-of-Flight ranging sensor with advanced multi-zone and multi-object detection

Datasheet - production data

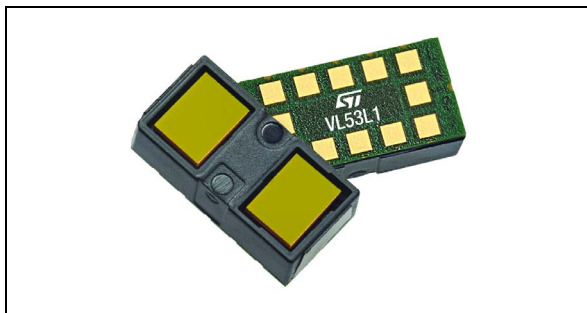

### Features

- **Fully integrated miniature module**
  - Emitter: 940 nm invisible laser (VCSEL) and its analog driver
  - Receiving array with integrated lens
  - Low-power microcontroller running advanced digital firmware
  - Size: 4.9 x 2.5 x 1.56 mm
- **Fast, accurate distance ranging**
  - 400 cm+ detection with full field of view (FoV)
  - 60 Hz ranging capable up to 300 cm
  - Immune to coverglass cross-talk and fingerprint smudge at long distance with patented algorithms (direct ToF)
  - Multi-object detection capability
  - Multi-zone scanning with selectable array (2x2, 3x3, 4x4, or defined by user through software)
- **Easy integration**
  - Reflowable component
  - Single power supply 2v8
  - Works with many types of cover glass materials
  - I<sup>2</sup>C interface (up to 1 MHz)
  - Xshutdown (reset) and interrupt GPIO
  - Full set of software driver (Linux and Android compatible) for turnkey ranging

### Applications

- Laser assisted auto-focus (AF): enhances the camera AF system speed and robustness, especially in difficult scenes (low light and low contrast); ideal companion for PDAF sensors
- Video focus tracking assistance at 60 Hz
- Scene understanding with multi object detection: “choose the focus point”
- Dual camera stereoscopy and 3D depth assistance thanks to multi zone measurement
- Presence detection (autonomous timed mode), typically to lock/unlock and power on/off devices like notebooks, tablets or white goods

### Description

The VL53L1 is a state-of-the-art, Time-of-Flight (ToF), laser-ranging, miniature sensor enhancing STMicroelectronics’ **FlightSense product** family. Housed in a miniature and reflowable package, it integrates a SPAD (single photon avalanche diode) array, physical infrared filters and optics to achieve the best ranging performance in various ambient lighting conditions, with a wide range of cover windows.

Unlike conventional IR sensors, the VL53L1 uses ST’s latest generation direct ToF technology which allows absolute distance measurement whatever the target color and reflectance. It provides accurate ranging above 4 m and can work at fast speeds (60 Hz), which makes it the **fastest miniature ToF sensor on the market**.

With patented algorithms and ingenious module construction, the VL53L1 is also able to detect **different objects within the field-of-view** with depth understanding at 60 Hz.

Scene browsing and **multi-zone detection** is now possible with the VL53L1, thanks to software customizable detection array for quicker “touch-to-focus” or mini depth-map use cases.

# Contents

<b>1</b>	<b>Product overview</b>	<b>4</b>
1.1	Technical specification	4
1.2	System block diagram	4
1.3	Device pinout	5
1.4	Application schematic	6
<b>2</b>	<b>Functional description</b>	<b>8</b>
2.1	System functional description	8
2.2	Firmware state machine description	9
2.3	Customer manufacturing calibration flow	10
2.4	Device programming and control	10
2.5	Description of operating “preset” modes	10
2.6	Digital processing and reading the results	11
2.7	Reading of the results	11
2.8	Power sequence	12
2.8.1	Power-up and boot sequence	12
2.9	Ranging sequence	13
2.10	Handshake management	13
<b>3</b>	<b>Control interface</b>	<b>14</b>
3.1	I <sup>2</sup> C interface - timing characteristics	16
3.2	I <sup>2</sup> C interface - reference registers	18
<b>4</b>	<b>Electrical characteristics</b>	<b>19</b>
4.1	Absolute maximum ratings	19
4.2	Recommended operating conditions	19
4.3	ESD	19
4.4	Current consumption	20
4.5	Electrical characteristics	21
<b>5</b>	<b>Ranging performances</b>	<b>22</b>
5.1	Measurement conditions	22

---

5.2	Minimum ranging distance	22
5.3	Ranging and Scanning modes: multi object detection	22
5.4	Ranging and Scanning modes: full FoV performance	22
5.5	Ranging and Scanning modes: partial FoV performances	24
5.5.1	Optical center definition	24
5.5.2	Partial FoV performances	25
5.6	Lite mode performances	26
5.7	Autonomous mode performances	26
<b>6</b>	<b>Outline drawing</b>	<b>27</b>
<b>7</b>	<b>Laser safety considerations</b>	<b>30</b>
<b>8</b>	<b>Packaging and labeling</b>	<b>31</b>
8.1	Product marking	31
8.2	Inner box labeling	31
8.3	Packing	31
8.4	Tape outline drawing	32
8.5	Pb-free solder reflow process	33
8.6	Handling and storage precautions	34
8.6.1	Shock precaution	34
8.6.2	Part handling	34
8.6.3	Compression force	34
8.6.4	Moisture sensitivity level	34
8.7	Storage temperature conditions	34
<b>9</b>	<b>Ordering information</b>	<b>35</b>
<b>10</b>	<b>Acronyms and abbreviations</b>	<b>35</b>
<b>11</b>	<b>ECOPACK<sup>®</sup></b>	<b>36</b>
<b>12</b>	<b>Revision history</b>	<b>37</b>

# 1 Product overview

## 1.1 Technical specification

Table 1. Technical specification

Feature	Detail
Package	Optical LGA12
Size	4.9 x 2.5 x 1.56 mm
Operating voltage	2.6 to 3.5 V
Operating temperature:	-20 to 85°C
Infrared emitter	940 nm
I <sup>2</sup> C	Up to 1MHz (Fast mode plus) serial bus Address: 0x52

## 1.2 System block diagram

Figure 1. VL53L1 block diagram

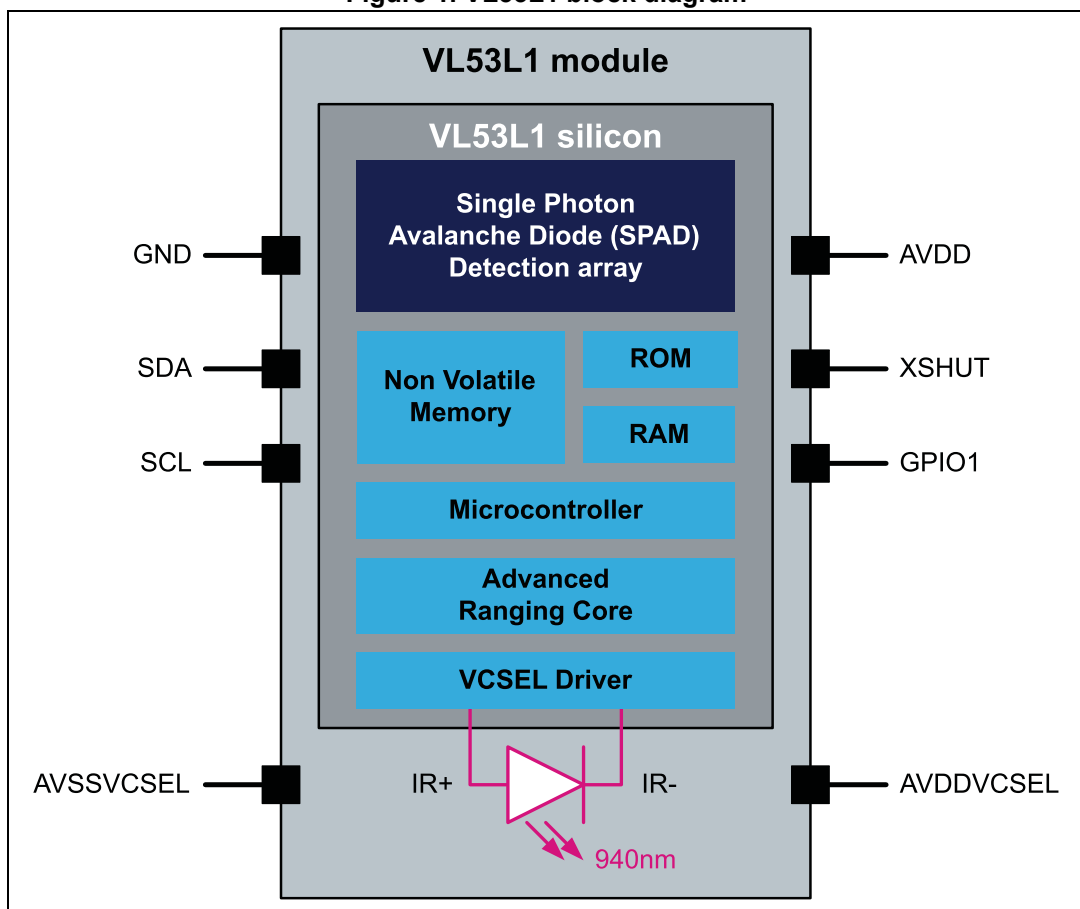

## 1.3 Device pinout

Figure 2 shows the pinout of the VL53L1 (see also Figure 17).

Figure 2. VL53L1 pinout (bottom view)

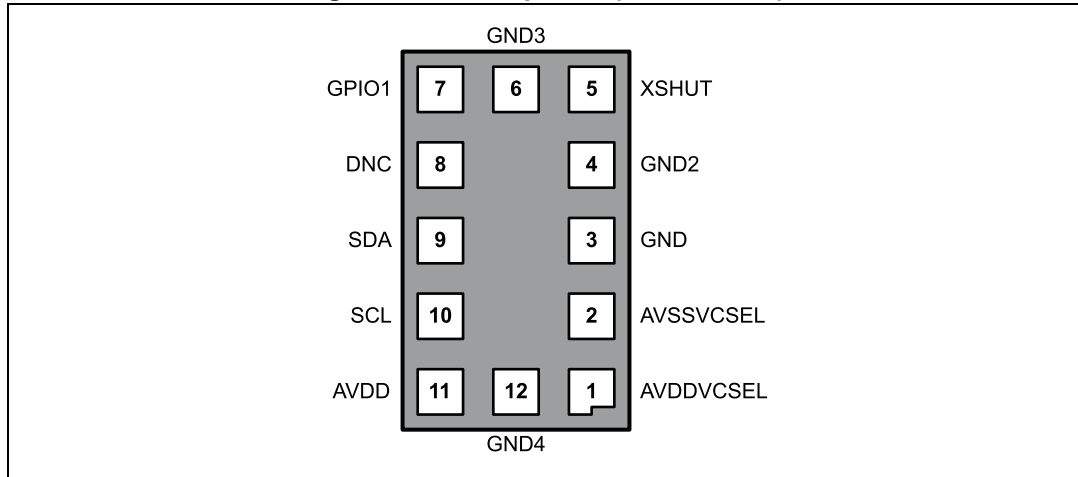

Table 2. VL53L1 pin description

Pin number	Signal name	Signal type	Signal description
1	AVDDVCSEL	Supply	VCSEL supply, to be connected to main supply
2	AVSSVCSEL	Ground	VCSEL ground, to be connected to main ground
3	GND	Ground	To be connected to main ground
4	GND2	Ground	To be connected to main ground
5	XSHUT	Digital input	Xshutdown pin, active low
6	GND3	Ground	To be connected to main ground
7	GPIO1	Digital output	Interrupt output. Open drain output.
8	DNC	Digital input	Do not connect, must be left floating.
9	SDA	Digital input/output	I <sup>2</sup> C serial data
10	SCL	Digital input	I <sup>2</sup> C serial clock input
11	AVDD	Supply	Supply, to be connected to main supply
12	GND4	Ground	To be connected to main ground

## 1.4 Application schematic

Figure 3 shows the application schematic of the VL53L1.

Figure 3. VL53L1 schematic

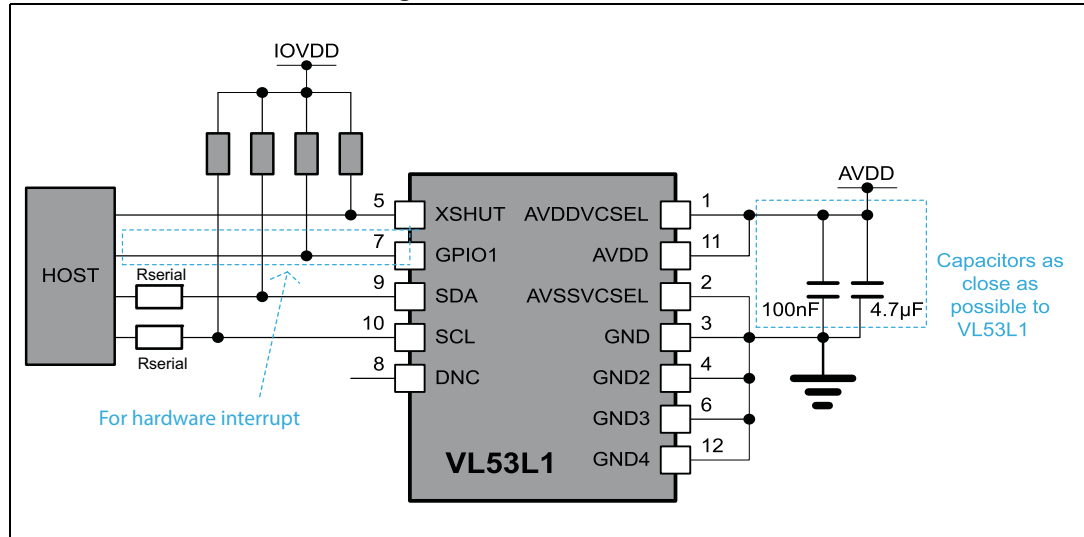

Note: Capacitors on external supply AVDD should be placed as close as possible to the AVDDVCSEL and AVSSVCSEL module pins.

Note: External pull-up resistor values can be found in I<sup>2</sup>C-bus specification. Pull-ups are typically fitted only once per bus, near the host. For suggested values see Table 3 and Table 4.

Note: XSHUT pin must always be driven to avoid leakage current. A pull-up is needed if the host state is not known.  
XSHUT is needed to use HW standby mode (no I<sup>2</sup>C communication).

Note: XSHUT and GPIO1 pull up recommended values are 10 kOhms

Note: GPIO1 to be left unconnected if not used

[Table 3](#) and [Table 4](#) show recommended values for pull-up and series resistors for an AVDD of 1.8 V to 2.8 V in I<sup>2</sup>C Fast mode (up to 400 kHz) and Fast mode plus (up to 1 MHz).

**Table 3. Suggested pull-up and series resistors for I<sup>2</sup>C Fast mode**

I <sup>2</sup> C load capacitance (C <sub>L</sub> ) <sup>(1)</sup>	Pull-up resistor (Ohms)	Series resistor (Ohms)
C <sub>L</sub> ≤ 90 pF	3.6 k	0
90 pF < C <sub>L</sub> ≤ 140 pF	2.4 k	0
140 pF < C <sub>L</sub> ≤ 270 pF	1.2 k	0
270 pF < C <sub>L</sub> ≤ 400 pF	0.8 k	0

1. For each bus line, C<sub>L</sub> is measured in application PCB by customer.

**Table 4. Suggested pull-up and series resistors for I<sup>2</sup>C Fast mode plus**

I <sup>2</sup> C load capacitance (C <sub>L</sub> ) <sup>(1)</sup>	Pull-up resistor (Ohms)	Series resistor (Ohms)
C <sub>L</sub> ≤ 90 pF	1.5 k	100
90 pF < C <sub>L</sub> ≤ 140 pF	1 k	50
140 pF < C <sub>L</sub> ≤ 270 pF	0.5 k	50
270 pF < C <sub>L</sub> ≤ 400 pF	0.3 k	50

1. For each bus line, C<sub>L</sub> is measured in application PCB by customer.

## 2 Functional description

### 2.1 System functional description

*Figure 4* shows the system level functional description. The host customer application controls the VL53L1 device using an API (application programming interface). The API implementation is delivered to the customer as a driver (Bare C code, or Linux/Android driver).

The driver shares with the customer application a set of high level functions that allow control of the VL53L1 Firmware (FW) like initialization, ranging start/stop, setting the system accuracy, and choice of ranging mode.

The driver is a turnkey solution consisting of a set of “C” functions that enables fast development of end user applications without the complication of direct multiple register access. The driver is structured in a way that it can be compiled on any kind of platform through a well abstracted platform layer. The driver package allows the user to take full advantage of VL53L1 capabilities.

A detailed description of the driver is available in the **VL53L1 driver user manual** (UM2133).

The VL53L1 FW fully manages the hardware (HW) register accesses.

*Section 2.2: Firmware state machine description* details the Firmware state machine.

**Figure 4. VL53L1 system functional description**

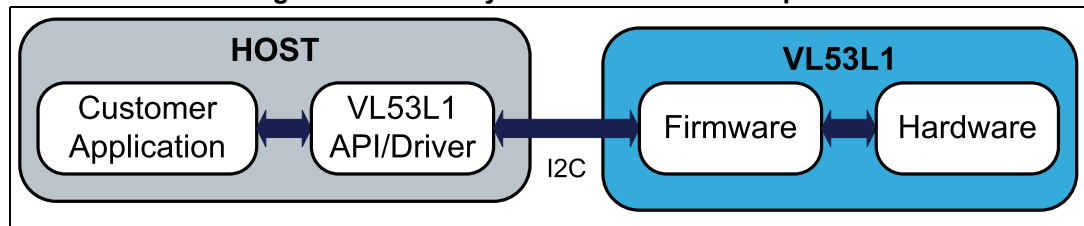



## 2.2 Firmware state machine description

Figure 5 shows the Firmware state machine.

Figure 5. Firmware state machine

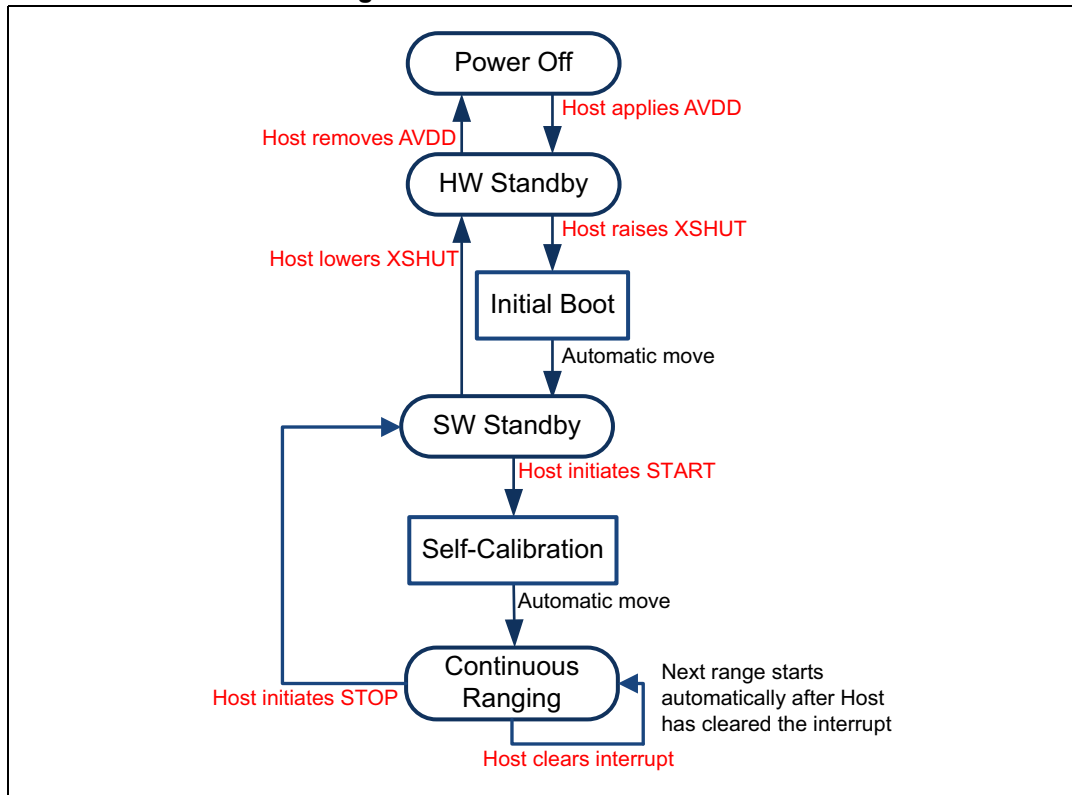

## 2.3 Customer manufacturing calibration flow

The detailed procedure is provided in the **VL53L1 driver user manual (UM2133)**.

## 2.4 Device programming and control

The VL53L1 physical control interface is I<sup>2</sup>C, described in [Section 3: Control interface](#).

A software layer (driver) is provided to control the device. This avoids complex I2C register operations with turnkey functions to start, stop and read the ranging values.

The driver structure and functions are described in the **VL53L1 driver user manual (UM2133)**.

## 2.5 Description of operating “preset” modes

The VL53L1 software driver proposes four turnkey operating modes (called “preset”) to allow fast and easy ranging in all customer applications:

- **Ranging mode**
- **Multizone scanning mode**
- **Lite ranging mode**
- **Autonomous mode**

**Ranging mode** is the default (recommended) configuration to get the best of the VL53L1 functionalities.

- Ranging mode is **natively immune to coverglass crosstalk and smudge beyond 80 cm**. With patented algorithms (direct Time-of-Flight), a temporal filtering is possible to distinguish crosstalk from object signal over long distance > 80 cm. Best-in-class ranging performance of 300 cm+ with coverglass in place is now possible, and can be reached with any computation unlike other sensors in the market.
- Ranging mode can detect several objects concurrently within the FoV. Up to four ranges can be output simultaneously by the software driver, to indicate objects range. Check the latest software driver manual for further details.
- Ranging mode is compatible with ROI (region of interest) selection: the user may choose a custom FoV by software, from 4x4 SPADs (minimum size) up to 16x16 SPADs (full FoV). This gives full flexibility to support “touch-to-focus” or custom ranging.
- Ranging operation is performed by default at 60 Hz once the driver function is called (typical ranging operation lasts 16 ms). It includes internal housekeeping, ranging and post-processing.

**Multizone scanning mode** provides ranging results of all selected ROIs sequentially: quadrant (4 zones), 9 zones, 16 zones or custom number of zones and location. In each ROI the VL53L1 system can also detect multiple objects, and the software driver returns a ranging quality level and signal, in addition to the distance in millimeters.

**Lite ranging mode** is recommended to minimize the post processing with a low-performance host (microcontroller or low frequency CPU).

**Autonomous mode** triggers ranging interrupts under certain conditions: the user can set distance thresholds, signal thresholds, and a timing interval between two consecutive ranging operations.

*Note:* Ranging, multizone scanning and lite ranging modes require a handshake between the host and the VL53L1, at each ranging operation. This handshake is mandatory to ensure the right result is read by the host to continue the ranging operation.

Please refer to section [Section 2.10: Handshake management](#) for further details.

## 2.6 Digital processing and reading the results

The **digital processing** is the final operation of the ranging sequence that computes, validates or rejects a ranging measurement. Part of this processing is performed by the VL53L1 internal firmware and completed on the host processor running the software driver.

At the end of the digital processing, the ranging distance is computed by the VL53L1 itself. If the distance cannot be measured (no target or weak signal), a corresponding status error code is generated and can be read by the host.

## 2.7 Reading of the results

The VL53L1 software driver provides turnkey functions to read output results after the measurement:

- Signal rate
- Ranging distance per object detected
- Min. and max. distances where object is located
- Dmax and range quality level

Full description is provided inside the **VL53L1 driver user manual (UM2133)**

## 2.8 Power sequence

### 2.8.1 Power-up and boot sequence

There are two options available for device power-up/boot.

**Option 1:** the XSHUT pin is connected and controlled from the host.

This option optimizes power consumption as the VL53L1 can be completely powered off when not used, and then woken up through the host GPIO (using the XSHUT pin).

HW Standby mode is defined as the period when AVDD is present and XSHUT is low.

**Figure 6. Power-up and boot sequence**

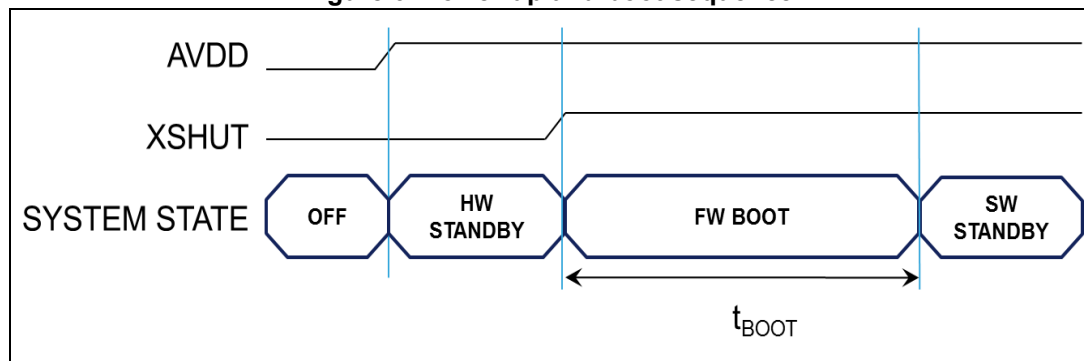

1.  $t_{BOOT}$  is 1.2ms max.

**Option 2:** the XSHUT pin is not controlled by the host, it is tied to AVDD through the pull-up resistor.

When the XSHUT pin is not controlled, the power-up sequence is presented in [Figure 7](#). In this case, the device goes automatically to SW STANDBY after FW BOOT, without entering HW STANDBY.

**Figure 7. Power-up and boot sequence with XSHUT not controlled**

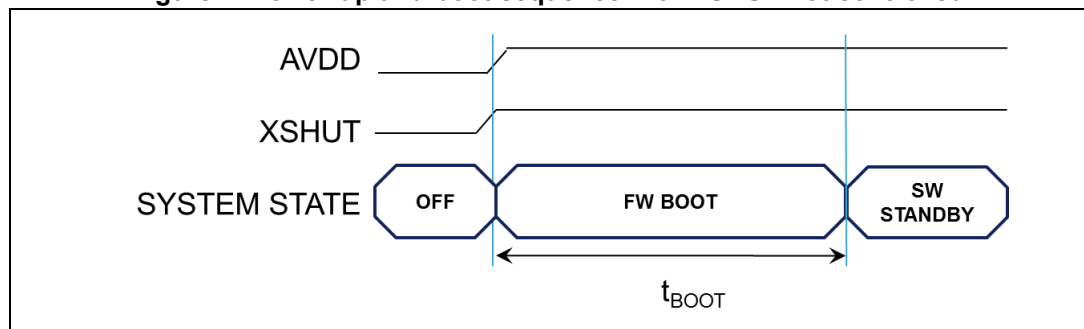

1.  $t_{BOOT}$  is 1.2 ms max.

*Note:* In all cases, XSHUT has to be raised only when AVDD is tied on.

## 2.9 Ranging sequence

Figure 8. Ranging sequence

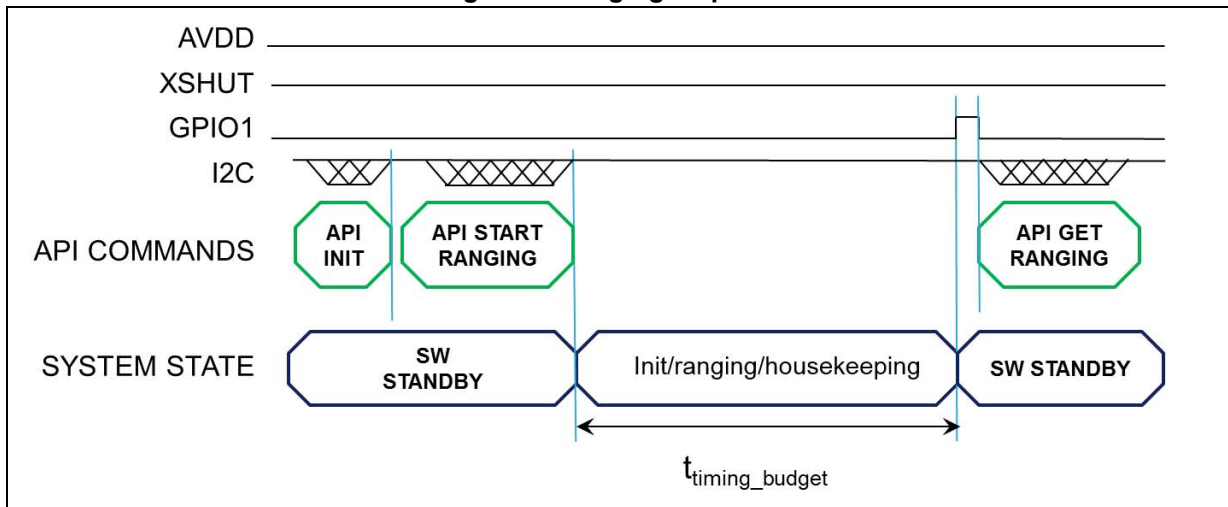

1.  $t_{\text{timing\_budget}}$  is a parameter set by the user, using a dedicated driver function.

## 2.10 Handshake management

For all ranging modes described above, every time a ranging measurement is available, an interrupt is generated. The GPIO1 pin of the VL53L1 is then driven high. Once the host reads the result the interrupt is cleared and the ranging sequence can repeat. If the interrupt is not cleared, the ranging operation inside the VL53L1 is on hold. It allows a good synchronization between the VL53L1 and the host, avoids losing results in case of delay on the I<sup>2</sup>C bus, and is mandatory for multizone scanning operations.

It is strongly recommended to use the hardware interrupt pin to manage this handshake. But if not possible a software polling mode remains available.

For more details please refer to **VL53L1 user manual (UM2133)**

### 3 Control interface

This section specifies the control interface. The I<sup>2</sup>C interface uses two signals: serial data line (SDA) and serial clock line (SCL). Each device connected to the bus uses a unique address and a simple master / slave relationships exists.

Both SDA and SCL lines are connected to a positive supply voltage using pull-up resistors located on the host. Lines are only actively driven low. A high condition occurs when lines are floating and the pull-up resistors pull lines up. When no data is transmitted both lines are high.

Clock signal (SCL) generation is performed by the master device. The master device initiates data transfer. The I<sup>2</sup>C bus on the VL53L1 has a maximum speed of 1 Mbits/s and uses a device address of 0x52.

Figure 9. Data transfer protocol

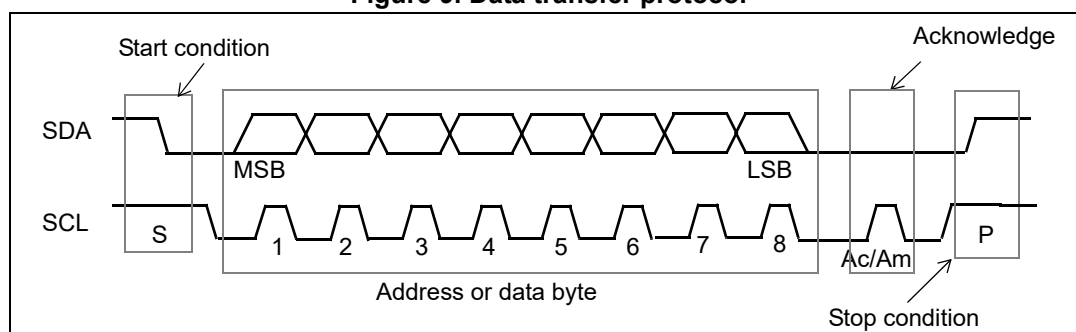

Information is packed in 8-bit packets (bytes) always followed by an acknowledge bit, Ac for VL53L1 acknowledge and Am for master acknowledge (host bus master). The internal data is produced by sampling SDA at a rising edge of SCL. The external data must be stable during the high period of SCL. The exceptions to this are start (S) or stop (P) conditions when SDA falls or rises respectively, while SCL is high.

A message contains a series of bytes preceded by a start condition and followed by either a stop or repeated start (another start condition but without a preceding stop condition) followed by another message. The first byte contains the device address (0x52) and also specifies the data direction. If the least significant bit is low (that is, 0x52) the message is a master-write-to-the-slave. If the lsb is set (that is, 0x53) then the message is a master-read-from-the-slave.

Figure 10. VL53L1 I<sup>2</sup>C device address: 0x52

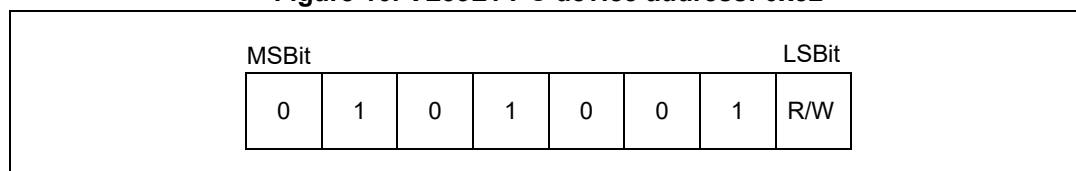

All serial interface communications with the Time-of-Flight sensor must begin with a start condition. The VL53L1 module acknowledges the receipt of a valid address by driving the SDA wire low. The state of the read/write bit (lsb of the address byte) is stored and the next byte of data, sampled from SDA, can be interpreted. During a write sequence, the second byte received provides a 16-bit index which points to one of the internal 8-bit registers.

Figure 11. VL53L1 data format (write)

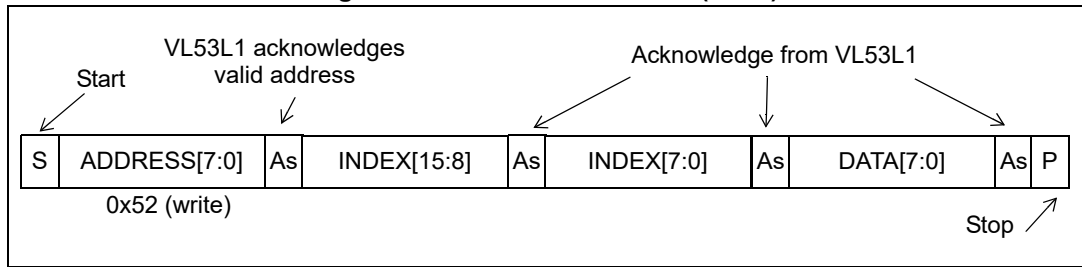

As data are received by the slave, they are written bit by bit to a serial/parallel register. After each data byte has been received by the slave, an acknowledge is generated, the data are then stored in the internal register addressed by the current index.

During a read message, the contents of the register addressed by the current index is read out in the byte following the device address byte. The contents of this register are parallel loaded into the serial/parallel register and clocked out of the device by the falling edge of SCL.

Figure 12. VL53L1 data format (read)

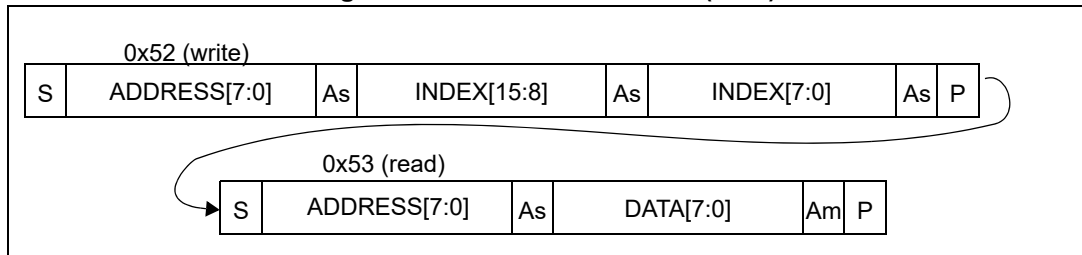

At the end of each byte, in both read and write message sequences, an acknowledge is issued by the receiving device (that is, the VL53L1 for a write and the host for a read).

A message can only be terminated by the bus master, either by issuing a stop condition or by a negative acknowledge (that is, **not** pulling the SDA line low) after reading a complete byte during a read operation.

The interface also supports auto-increment indexing. After the first data byte has been transferred, the index is automatically incremented by 1. The master can therefore send data bytes continuously to the slave until the slave fails to provide an acknowledge or the master terminates the write communication with a stop condition. If the auto-increment feature is used the master does **not** have to send address indexes to accompany the data bytes.

Figure 13. VL53L1 data format (sequential write)

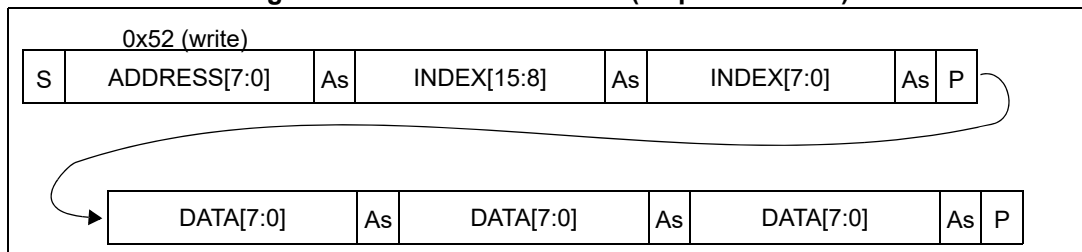
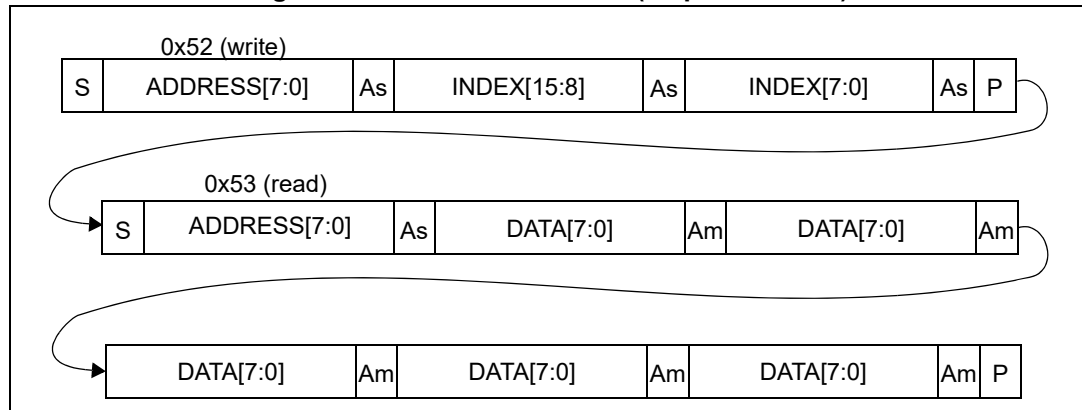

Figure 14. VL53L1 data format (sequential read)



### 3.1 I<sup>2</sup>C interface - timing characteristics

Timing characteristics are shown in [Table 6](#). Please refer to [Figure 15](#) for an explanation of the parameters used.

Timings are given for all PVT conditions.

**Table 5. I<sup>2</sup>C interface - timing characteristics for Fast mode plus (1 MHz)**

Symbol	Parameter	Minimum	Typical	Maximum	Unit
F <sub>I2C</sub>	Operating frequency	0	-	1000	kHz
t <sub>LOW</sub>	Clock pulse width low	0.5	-	-	μs
t <sub>HIGH</sub>	Clock pulse width high	0.26	-	-	
t <sub>SP</sub>	Pulse width of spikes which are suppressed by the input filter	-	-	50	ns
t <sub>BUF</sub>	Bus free time between transmissions	0.5	-	-	μs
t <sub>HD.STA</sub>	Start hold time	0.26	-	-	μs
t <sub>SU.STA</sub>	Start set-up time	0.26	-	-	
t <sub>HD.DAT</sub>	Data in hold time	0	-	0.9	
t <sub>SU.DAT</sub>	Data in set-up time	50	-	-	ns
t <sub>R</sub>	SCL/SDA rise time	-	-	120	
t <sub>F</sub>	SCL/SDA fall time	-	-	120	
t <sub>SU.STO</sub>	Stop set-up time	0.26	-	-	μs
C <sub>i/o</sub>	Input/output capacitance (SDA)	-	-	10	pF
C <sub>in</sub>	Input capacitance (SCL)	-	-	4	
C <sub>L</sub>	Load capacitance	-	140	550	



Table 6. I<sup>2</sup>C interface - timing characteristics for Fast mode (400 kHz)

Symbol	Parameter	Minimum	Typical	Maximum	Unit
F <sub>I2C</sub>	Operating frequency	0	-	400	kHz
t <sub>LOW</sub>	Clock pulse width low	1.3	-	-	μs
t <sub>HIGH</sub>	Clock pulse width high	0.6	-	-	
t <sub>SP</sub>	Pulse width of spikes which are suppressed by the input filter	-	-	50	ns
t <sub>BUF</sub>	Bus free time between transmissions	1.3	-	-	μs
t <sub>HD.STA</sub>	Start hold time	0.26	-	-	μs
t <sub>SU.STA</sub>	Start set-up time	0.26	-	-	
t <sub>HD.DAT</sub>	Data in hold time	0	-	0.9	
t <sub>SU.DAT</sub>	Data in set-up time	50	-	-	ns
t <sub>R</sub>	SCL/SDA rise time	-	-	300	
t <sub>F</sub>	SCL/SDA fall time	-	-	300	
t <sub>SU.STO</sub>	Stop set-up time	0.6	-	-	μs
C <sub>i/o</sub>	Input/output capacitance (SDA)	-	-	10	pF
C <sub>in</sub>	Input capacitance (SCL)	-	-	4	
C <sub>L</sub>	Load capacitance	-	125	400	

Figure 15. I<sup>2</sup>C timing characteristics

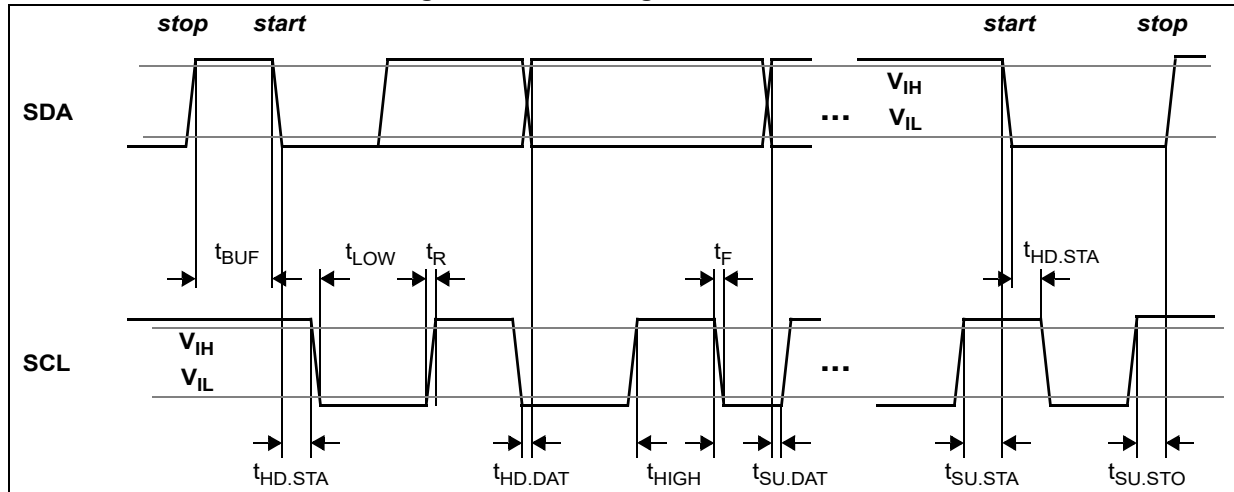

All timings are measured from either V<sub>IL</sub> or V<sub>IH</sub>.

### 3.2 I<sup>2</sup>C interface - reference registers

The registers shown in the table below can be used to validate the user I<sup>2</sup>C interface.

**Table 7. Reference registers**

Register name	Index	After fresh reset, without driver loaded
Model_ID	0x010F	0xEA
Module_Type	0x0110	0xCC

*Note:* The I<sup>2</sup>C read/writes can be 8, 16 or 32-bit. Multi-byte reads/writes are always addressed in ascending order with MSB first as shown in [Table 8](#).  
The customer must use the VL53L1 software driver for easy and efficient ranging operations to match performance and accuracy criteria. Hence full register details are not exposed. The customer should refer to the **VL53L1 user manual (UM2133)**.

**Table 8. 32-bit register example**

Register address	Byte
Address	MSB
Address + 1	..
Address + 2	..
Address + 3	LSB

## 4 Electrical characteristics

### 4.1 Absolute maximum ratings

Table 9. Absolute maximum ratings

Parameter	Min.	Typ.	Max.	Unit
AVDD	-0.5	-	3.6	V
SCL, SDA, XSHUT and GPIO1	-0.5	-	3.6	

*Note:* Stresses above those listed in [Table 9](#), may cause permanent damage to the device. This is a stress rating only and functional operation of the device at these or any other conditions above those indicated in the operational sections of the specification is not implied. Exposure to absolute maximum rating conditions for extended periods may affect device reliability.

### 4.2 Recommended operating conditions

Table 10. Recommended operating conditions <sup>(1)</sup>

Parameter	Min.	Typ.	Max.	Unit	
Voltage (AVDD)	2.6	2.8	3.5	V	
IO (IOVDD) <sup>(2)</sup>	Standard mode	1.6	1.8		1.9
	2V8 mode <sup>(3)</sup> <sup>(4)</sup>	2.6	2.8		3.5
Ambient temperature (normal operating)	-20		+85	°C	

- There are no power supply sequencing requirements. The I/Os may be high, low or floating when AVDD is applied. The I/Os are internally failsafe with no diode connecting them to AVDD
- XSHUT should be high level only when AVDD is on.
- SDA, SCL, XSHUT and GPIO1 high levels have to be equal to AVDD in 2V8 mode.
- The default Driver mode is 1V8. 2V8 mode is programmable using device settings loaded by the driver. For more details please refer to the VL53L1 driver user manual (UM2133).

### 4.3 ESD

The VL53L1 is compliant with ESD values presented in [Table 11](#)

Table 11. ESD performances

Parameter	Specification	Conditions
Human body model	JS-001-2012	± 2 kV, 1500 Ohms, 100 pF
Charged device model	JZSD22-C101	± 500 V

## 4.4 Current consumption

**Table 12. Power consumption at ambient temperature <sup>(1)</sup>**

Parameter	Min.	Typ.	Max.	Unit
HW STANDBY	3	5	7	uA
SW STANDBY (2V8 mode) <sup>(2)</sup>	4	6	9	
Timed ranging Inter measurement		20		
Active Ranging average consumption (including VCSEL) <sup>(3) (4)</sup>		16	18	mA
Average power consumption at 10 Hz with 33 ms ranging sequence			20	mW

1. All current consumption values include silicon process variations. Temperature and voltage are nominal conditions (23 °C and 2v8).

All values include AVDD and AVDDVCSEL.

2. In standard mode (1v8), pull-ups have to be modified, then SW STANDBY consumption is increased by +0.6 µA.

3. Active ranging is an average value, measured using default driver settings. Ranging mode with default settings @ 16ms timing budget.

4. Peak current (including VCSEL) can reach 40mA.

## 4.5 Electrical characteristics

Table 13. Digital I/O electrical characteristics

Symbol	Parameter	Min.	Typ.	Max.	Unit
<b>Interrupt pin (GPIO1)</b>					
$V_{IL}$	Low level input voltage	-	-	0.3 IOVDD	V
$V_{IH}$	High level input voltage	0.7 IOVDD		-	
$V_{OL}$	Low level output voltage ( $I_{OUT} = 4$ mA)	-		0.4	
$V_{OH}$	High level output voltage ( $I_{OUT} = 4$ mA)	IOVDD-0.4		-	
$F_{GPIO}$	Operating frequency ( $C_{LOAD} = 20$ pF)	0		108	MHz
<b>I<sup>2</sup>C interface (SDA/SCL)</b>					
$V_{IL}$	Low level input voltage	-0.5	-	0.6	V
$V_{IH}$	High level input voltage	1.12		IOVDD+0.5	
$V_{OL}$	Low level output voltage ( $I_{OUT} = 4$ mA)	-		0.4	
$I_{IL}/I_H$	Leakage current <sup>(1)</sup>	-		10	$\mu$ A
	Leakage current <sup>(2)</sup>	-		0.15	

1. AVDD = 0 V

2. AVDD = 2.85 V; I/O voltage = 1.8 V

## 5 Ranging performances

### 5.1 Measurement conditions

In all measurement tables of the document, it is considered that:

1. The full field of view (FoV) is covered (typically 27 °) or a partial FoV is covered after a specific ROI definition by the user (array size from 4x4 SPADs to 16x16 SPADs).
2. Charts used as targets are: grey (17 % reflectance, N4.74 Munsell) and white (88 % reflectance N9.5 Munsell).
3. Nominal voltage (2.8 V) and temperature (23 °C).
4. Unless mentioned, the device is controlled through the driver using the default settings (refer to the user manual for driver settings description).
5. Detection rate is considered as 94 %.
6. Indoor (no IR) means there is no contribution of light in the band 940 nm ± 30 nm. Outdoor overcast conditions means an illumination level of 0.7 W/m<sup>2</sup> back on the sensor, in the band 940 nm ± 30 nm.
7. No coverglass is present
8. A gain correction is available in the driver. The performance assumes average gain correction has been applied

### 5.2 Minimum ranging distance

The minimum ranging distance guaranteed is 4 cm. This is valid for all modes (ranging, scanning, lite, and autonomous)

### 5.3 Ranging and Scanning modes: multi object detection

Thanks to direct time of flight principle and ST patents, the VL53L1 is able to detect up to 4 objects in the FoV.

The typical depth separation between objects has to be at least 80 cm.

### 5.4 Ranging and Scanning modes: full FoV performance

With default SW driver settings, performances with full field of view (grey and white targets) with 16 ms timing budget are provided in [Table 14](#).

Table 14. Performances with Full FoV at 60Hz

Applicable to: Ranging and Scanning modes		Dark or indoor (no infrared)			Outdoor overcast		
Target color	Performances full FoV	Min.	Typ.	Max	Min.	Typ.	Max
White target	Max. distance detection	320 cm	320 cm	-	70 cm	90 cm	
	Accuracy	-	-	1 %	-	-	8.5 %
	Ranging offset	-	-	± 25mm		-	± 25 mm
Grey target	Max distance	180 cm	230 cm	-	70 cm	90 cm	-
	Accuracy	-	-	2.5%	-	-	8.5 %
	Ranging offset		-	± 25mm	-	-	± 25 mm

*Note: It is assumed that offset calibration is performed.*

## 5.5 Ranging and Scanning modes: partial FoV performances

### 5.5.1 Optical center definition

Sensing array optical center specification takes into account the part-to-part variation in production.

Optical center is defined by (Xo, Yo) coordinates.

Optical center is measured for each part during a factory test at STMicroelectronics. The coordinates are stored in the VL53L1 non-volatile memory and are readable by customer through software driver in the application. This helps optimizing its design, alignment with camera and ranging performances in the application.

The green array in [Figure 16: Optical center specification](#) gives the possible location of the optical center.

The user can define its own priority:

- **Priority FoV:** full matrix 16x16 active, max. ranging distance on corners maybe smaller than in the center.
- **Priority distance:** cropped matrix around the optical center. Refer to [Table 16: Ranging and Scanning modes: performance with partial FoV](#) to get the target performances in this case.

**Table 15. Optical center specification**

Parameter	Min.	Typ.	Max.	Unit
Xo offset	-2	0	2	SPAD
Yo offset	-2	0	2	

**Figure 16. Optical center specification**

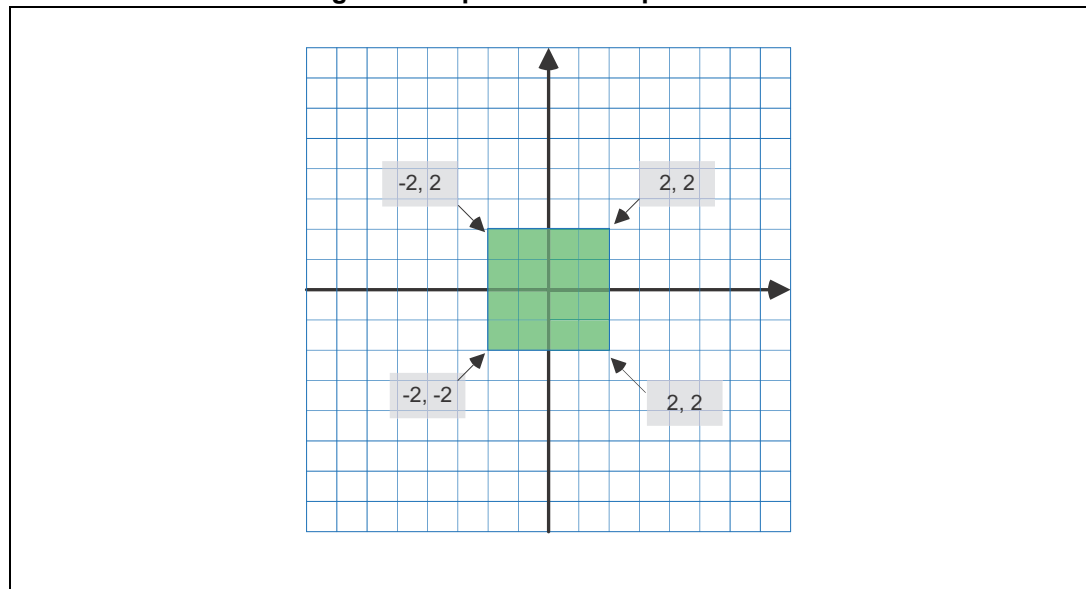



## 5.5.2 Partial FoV performances

With default SW driver settings, performances with partial Field of View (grey and white targets) with 16ms timing budget per zone are provided in [Table 16](#).

**Table 16. Ranging and Scanning modes: performance with partial FoV**

Applicable to: Ranging and Scanning modes		8x8 SPADs ROI array		4x4 SPADs ROI array	
	ROI	In corner	Centered	In corner	Centered
Target color	ROI center location	4 SPADs max. from optical center	ROI center = optical center	6 SPADs max from optical center	ROI center = optical center
White Target	Max distance detection	Typ. = 250 cm Min. = 190 cm	Typ. = 250 cm Min. = 250 cm	Typ. = 110cm Min. = 50cm	Typ. = 170 cm Min. =150 cm
	Accuracy	2 %	2 %	3 %	3 %
	Ranging offset	± 25 mm	± 25 mm	± 25 mm	± 25 mm
Grey Target	Max distance detection	Typ. =125 cm Min. = 70 cm	Typ. = 155 cm Min. = 100 cm	Typ. = 50 cm Min. = 20 cm	Typ. = 90 cm Min. = 50 cm
	Accuracy	5 %	5 %	10 %	10 %
	Ranging offset	± 25 mm	± 25 mm	± 25 mm	± 25 mm

*Note:* It is assumed that per ROI offset calibration is performed.

*Note:* The performance table is specified after optical centering of the VL53L1 defined in the user manual. The optical center of the VL53L1 is stored in the VL53L1 NVM and can be read by the user through the software driver.

### 5.6 Lite mode performances

Performances for Lite mode, as defined in the software driver, are provided in [Table 17](#).

**Table 17. Lite mode: performances with full FoV**

Applicable to: Lite mode with default settings		Dark or indoor (no infrared)		
Target color	Performance	15 Hz (default, recommended)		
		Min.	Typ.	Max.
White target	Max. distance detection	330	410 cm	-
	Accuracy	-	-	2.5 %
	Ranging offset	-	-	± 25 mm
Grey target	Max distance detection	130 cm	170 cm	-
	Accuracy	-	-	2.5 %
	Ranging offset	-	-	± 25 mm

### 5.7 Autonomous mode performances

Performances for Autonomous mode, as defined in the software driver, are provided in [Table 18](#).

**Table 18. Autonomous mode: performances with full FoV**

Applicable to: Autonomous mode with default settings		Dark or indoor (no infrared)		
Target color	Performance	76 ms timing budget		
		Min	Typ.	Max
White target	Max distance detection	-	280 cm	-
	Accuracy		-	1.5 %
	Ranging offset		-	± 25 mm
Grey target	Max distance detection		160 cm	-
	Accuracy		-	2.5 %
	Ranging offset		-	± 25 mm

The accuracy of the ranging thresholds programmed by user in autonomous mode are compliant with the values described in [Table 18](#).

# 6 Outline drawing

Figure 17. Outline drawing (page 1/3)

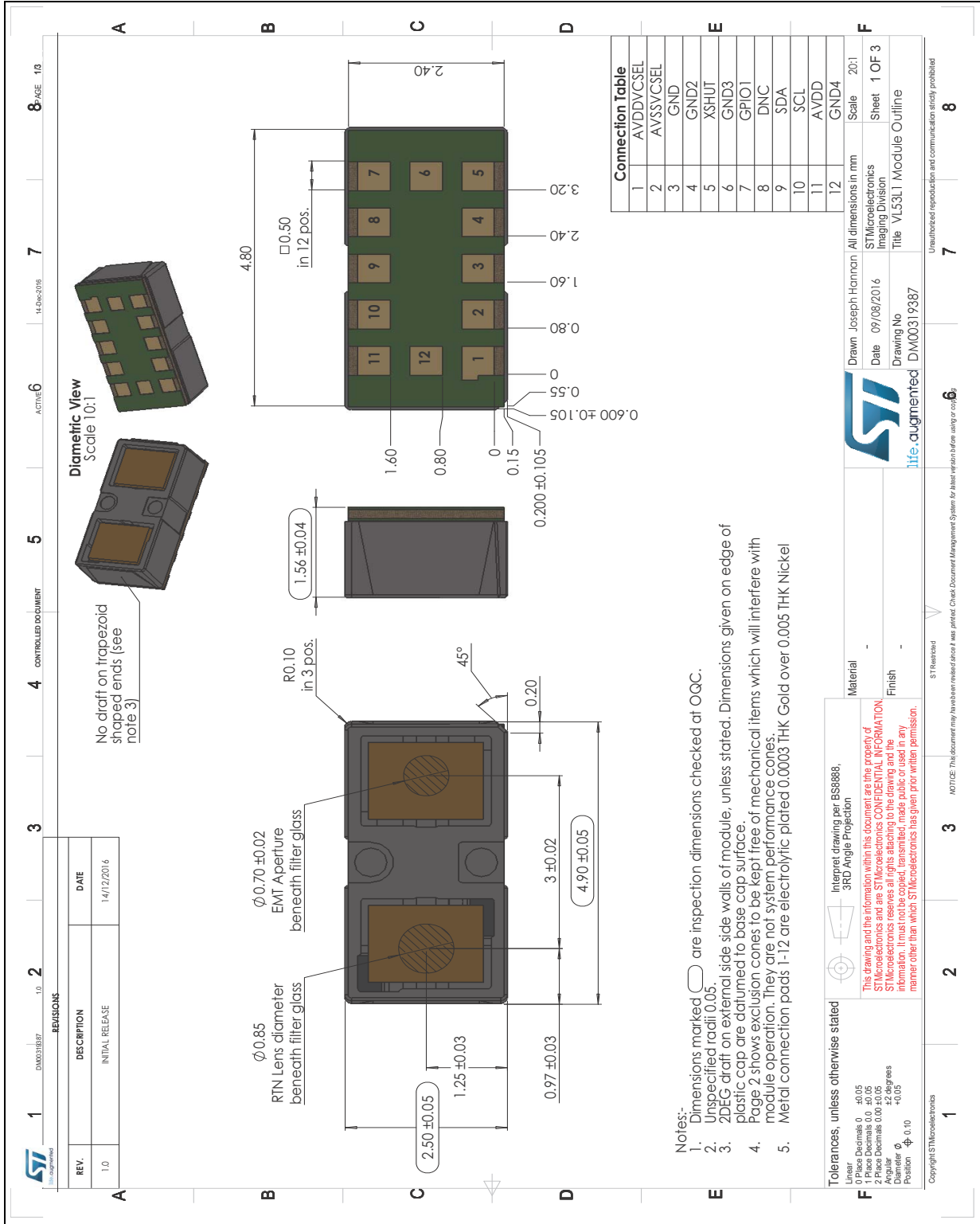

Figure 18. Outline drawing (page 2/3)

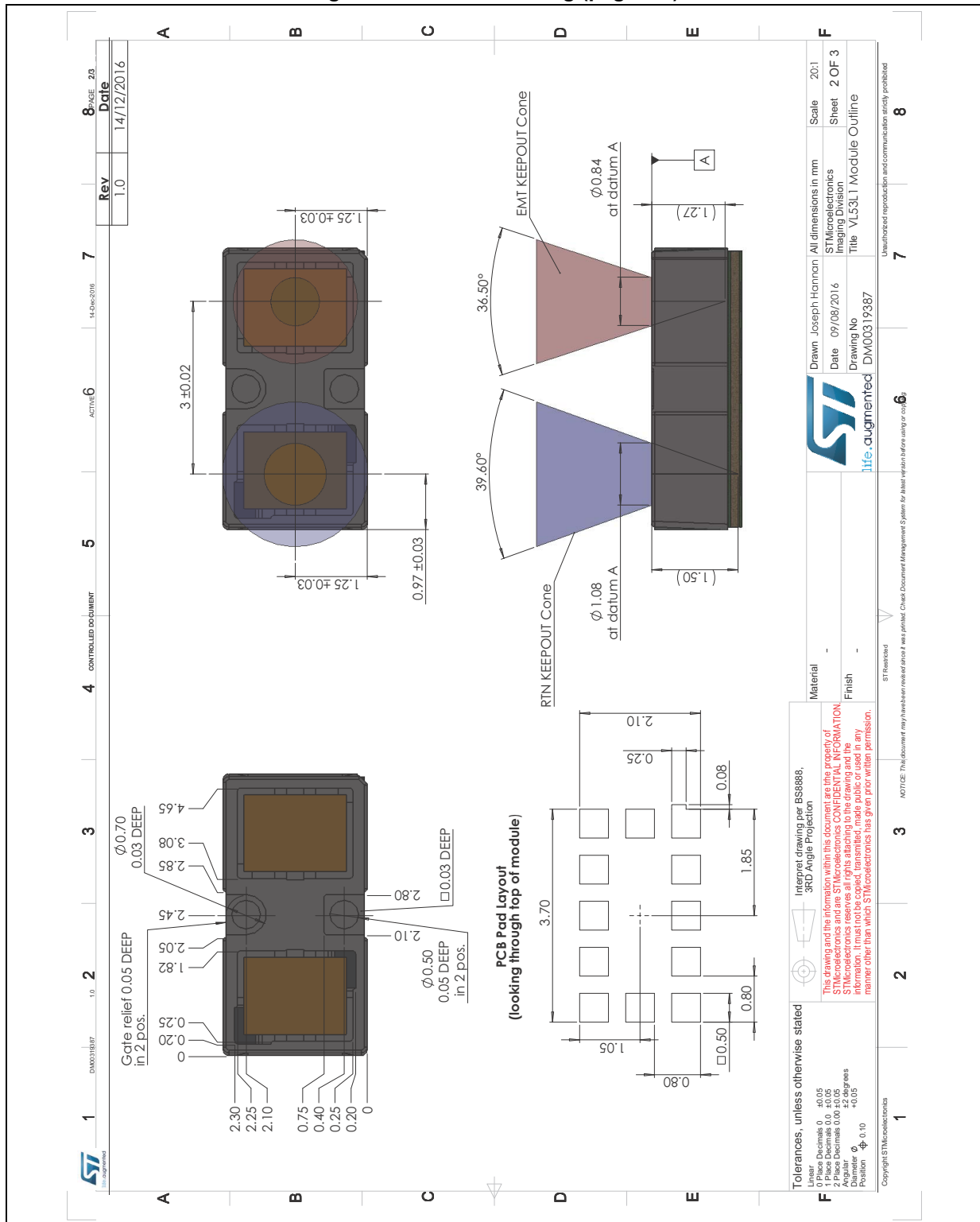
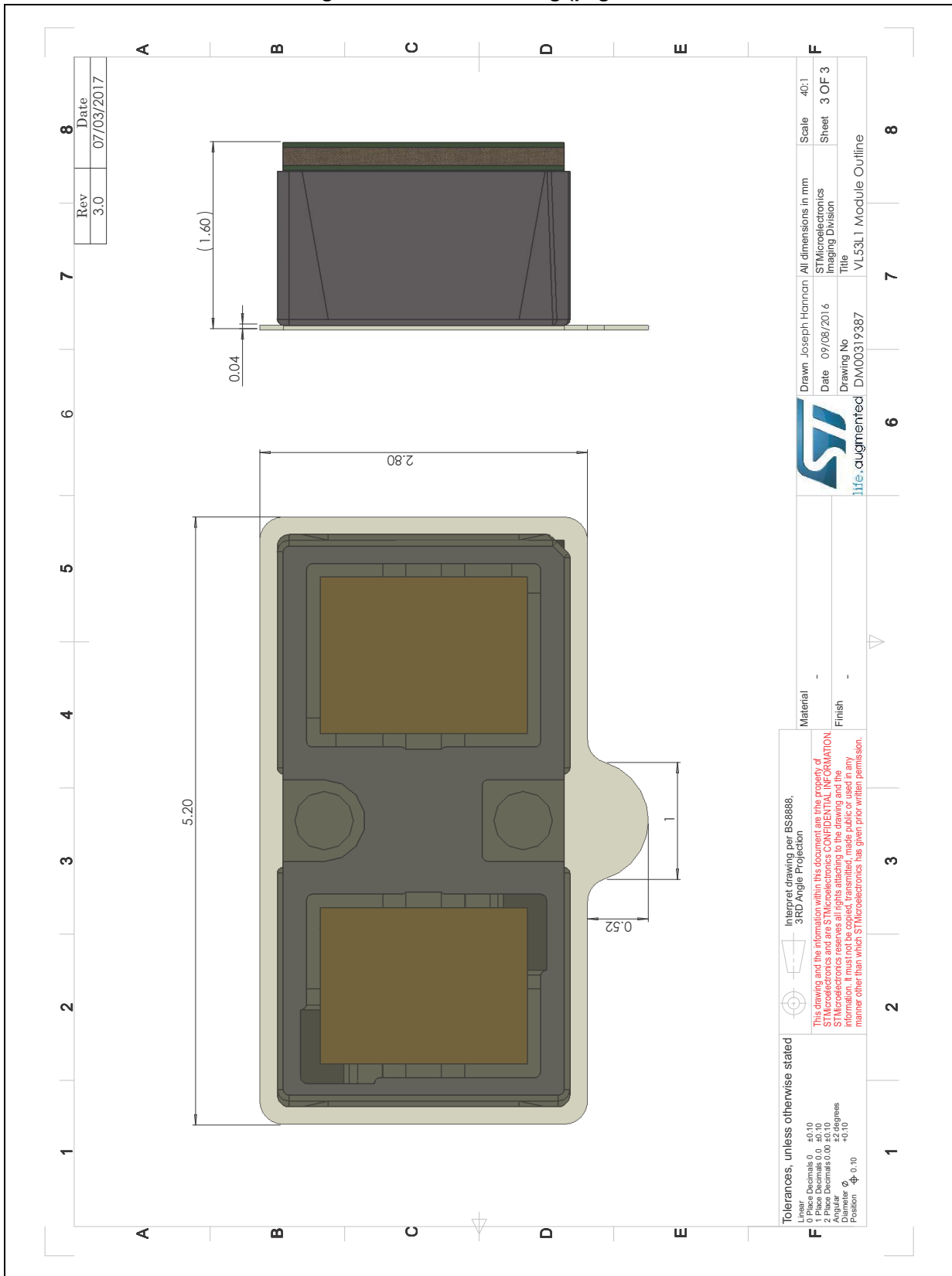

Figure 19. Outline drawing (page 3/3)



## 7 Laser safety considerations

The VL53L1 contains a laser emitter and corresponding drive circuitry. The laser output is designed to remain within Class 1 laser safety limits under all reasonably foreseeable conditions including single faults in compliance with IEC 60825-1:2014 (third edition).

The laser output remains within Class 1 limits as long as STMicroelectronic's recommended device settings are used and the operating conditions specified are respected (particularly the maximum timing budget, as described in the user manual UM2133).

The laser output power must not be increased by any means and no optics should be used with the intention of focusing the laser beam.

**Caution:** Use of controls or adjustments or performance of procedures other than those specified herein may result in hazardous radiation exposure.

Figure 20. Class 1 laser product label



## 8 Packaging and labeling

### 8.1 Product marking

A 2-line product marking is applied on the backside of the module (i.e. on the substrate). The first line is the silicon product code, and the second line, the internal tracking code.

Figure 21. Example of prototype marking



### 8.2 Inner box labeling

The labeling follows the ST standard packing acceptance specification.

The following information will be on the inner box label:

- Assembly site
- Sales type
- Quantity
- Trace code
- Marking
- Bulk ID number

### 8.3 Packing

At customer/subcontractor level, it is recommended to mount the VL53L1 in a clean environment to avoid foreign material deposition.

To help avoid any foreign material contamination at phone assembly level the modules will be shipped in a tape and reel format with a protective liner, starting from production version (cut1.1).

The packaging will be vacuum-sealed and include a desiccant.

The liner is compliant with reflow at 260 °C. It must be removed during assembly of the customer device, just before mounting the cover glass.

### 8.4 Tape outline drawing

Figure 22. Tape outline drawing

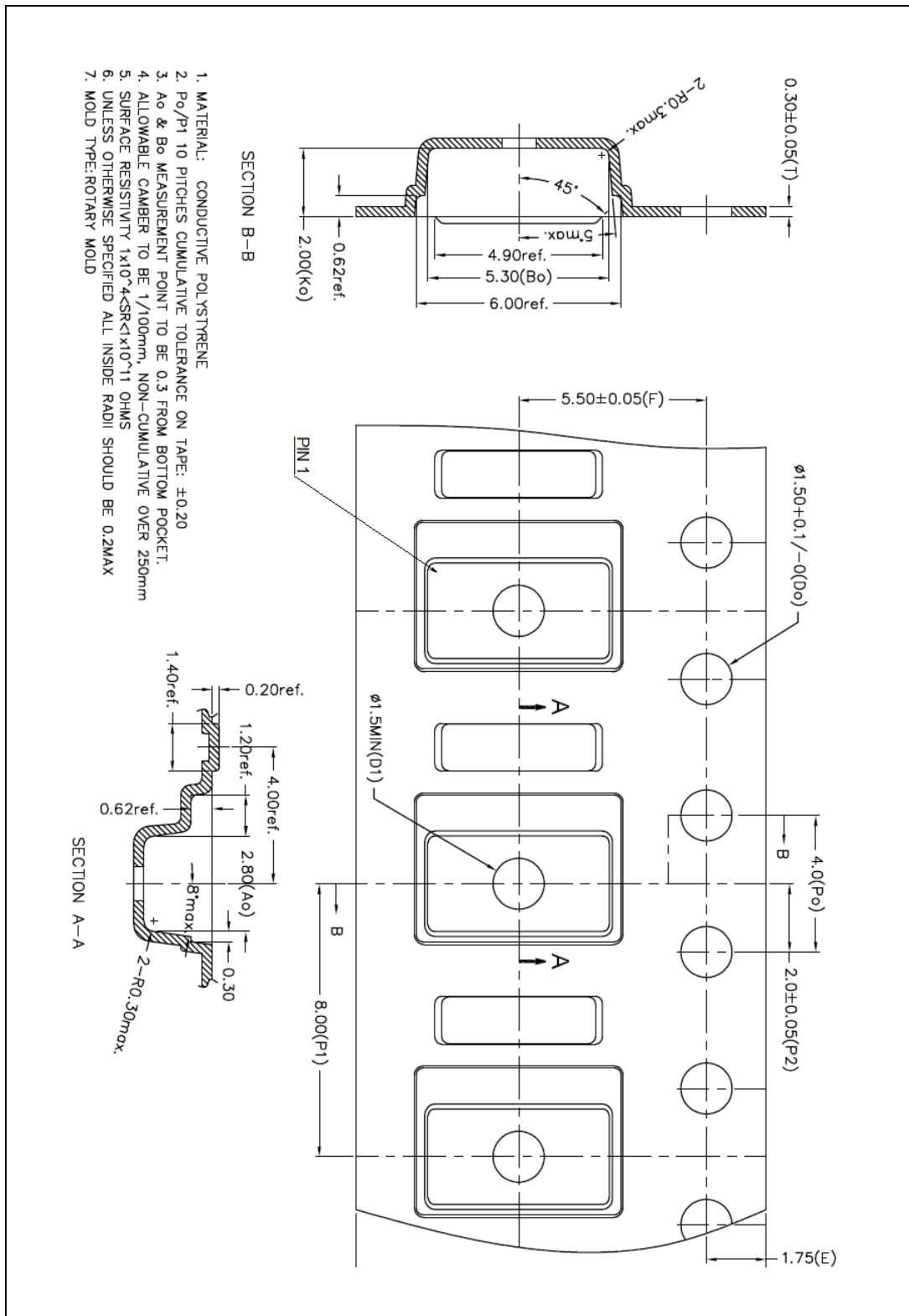



## 8.5 Pb-free solder reflow process

[Figure 23](#) and [Table 19](#) shows the recommended and maximum values for the solder profile.

Customers have to tune the reflow profile depending on the PCB, solder paste and material used. We expect customers to follow the “recommended” reflow profile, which is specifically tuned for VL53L1 package.

For any reason, if a customer must perform a reflow profile which is different from the “recommended” one (especially peak  $>240\text{ °C}$ ), this new profile must be qualified by the customer at their own risk. In any case, the profile have to be within the “maximum” profile limit described in [Table 19](#).

**Table 19. Recommended solder profile**

Parameters	Recommended	Maximum	Units
Minimum temperature ( $T_S$ min)	130	150	°C
Maximum temperature ( $T_S$ max)	200	200	°C
Time $t_S$ ( $T_S$ min to $T_S$ max)	90-110	60 - 120	s
Temperature ( $T_L$ )	217	217	°C
Time ( $t_L$ )	55-65	55 - 65	s
Ramp up	2	3	°C/s
Temperature ( $T_{p-10}$ )	-	235	°C
Time ( $t_{p-10}$ )	-	10	s
Ramp up	-	3	°C/s
Peak temperature ( $T_p$ )	240	245	°C
Time to peak	300	300	s
Ramp down (peak to $T_L$ )	-4	-6	°C/s

**Figure 23. Solder profile**

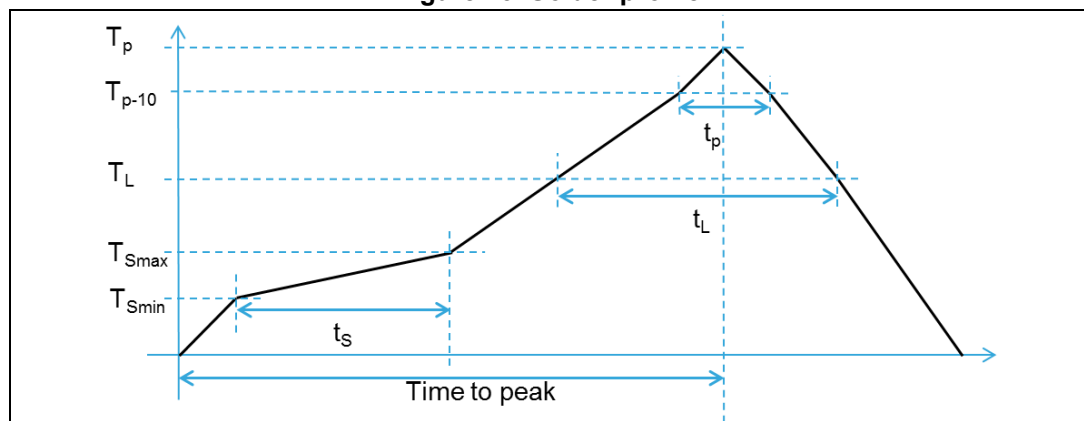

Note: Temperature mentioned in [Table 19](#) is measured at the top of the VL53L1 package.

Note: The component should be limited to a maximum of three passes through this solder profile.

Note: As the VL53L1 package is not sealed, only a dry reflow process should be used (such as convection reflow). Vapor phase reflow is not suitable for the VL53L1 because it is an optical component. Consequently, the VL53L1 should be treated carefully. This would typically include using a ‘no-wash’ assembly process.

## 8.6 Handling and storage precautions

### 8.6.1 Shock precaution

Sensor modules house numerous internal components that are susceptible to shock damage. If a unit is subject to excessive shock, is dropped on the floor, or a tray/reel of units is dropped on the floor, it must be rejected, even if no apparent damage is visible.

### 8.6.2 Part handling

Handling must be done with non-marring ESD safe carbon, plastic, or teflon tweezers. Ranging modules are susceptible to damage or contamination. The customer is advised to use a clean assembly process after removing the tape from the parts, and until a protective cover glass is mounted.

### 8.6.3 Compression force

A maximum compressive load of 25 N should be applied on the module.

### 8.6.4 Moisture sensitivity level

Moisture sensitivity is level 3 (MSL) as described in IPC/JEDEC JSTD-020-C

## 8.7 Storage temperature conditions

Table 20. Recommended storage conditions

Parameter	Min.	Typ.	Max.	Unit
Temperature (storage)	-40	23	125	°C

## 9 Ordering information

**Table 21. Order codes**

Sales type	Package	Packing	Minimum order quantity
VL53L1CBV0FY/1	Optical LGA12 with liner	Tape and reel	3600pcs

## 10 Acronyms and abbreviations

**Table 22. Acronyms and abbreviations**

Acronym/abbreviation	Definition
ESD	Electrostatic discharge
I <sup>2</sup> C	Inter-integrated circuit (serial bus)
NVM	Non volatile memory
SPAD	Single photon avalanche diode
FoV	Field of view
VCSEL	Vertical cavity surface emitting laser

## 11 ECOPACK®

In order to meet environmental requirements, ST offers these devices in different grades of ECOPACK® packages, depending on their level of environmental compliance. ECOPACK® specifications, grade definitions and product status are available at: [www.st.com](http://www.st.com). ECOPACK® is an ST trademark.

*Note:* The ECOPACK® grade for VL53L1 is ECOPACK®2.

## 12 Revision history

**Table 23. Document revision history**

Date	Revision	Changes
14 Apr 2017	1	Initial release
28-Apr-2017	2	Document status updated to "production data". Added: <a href="#">Section 5.2: Minimum ranging distance</a> <a href="#">Section 5.3: Ranging and Scanning modes: multi object detection</a> <a href="#">Section 8.4: Tape outline drawing</a> Modified <a href="#">Section 2.8.1: Power-up and boot sequence</a> : added a note on XSHUT pin.
09-Jun-2017	3	Removed "preliminary" from <a href="#">Section 5: Ranging performances</a> . Updated: <a href="#">Table 16: Ranging and Scanning modes: performance with partial FoV</a> , <a href="#">Table 17: Lite mode: performances with full FoV</a> , and <a href="#">Table 18: Autonomous mode: performances with full FoV</a> .
08-Dec-2017	4	Updated <a href="#">Table 7: Reference registers</a> <a href="#">Section 8.5: Pb-free solder reflow process</a> : added note about reflow process needed for the VL53L1.
29-Nov-2018	5	Replaced <a href="#">Figure 5: Firmware state machine</a> <a href="#">Section 2.5: Description of operating "preset" modes</a> : removed some information about "timing budgets". <a href="#">Table 5</a> : updated units of $t_{BUF}$ parameter <a href="#">Table 6</a> : updated units of $t_{BUF}$ parameter and updated maximum values of $t_R$ and $t_{R-}$ . <a href="#">Section 5.1: Measurement conditions</a> : updated detection rate from 100 % to 94 %. <a href="#">Section 5.4: Ranging and Scanning modes: full FoV performance</a> : small text change (of to and). <a href="#">Section 5.5.2: Partial FoV performances</a> : small text change (of to and), added "offset" to first note. Replaced <a href="#">Figure 19: Outline drawing (page 3/3)</a> <a href="#">Section 7: Laser safety considerations</a> : updated text concerning laser output limits in Class 1.
20-Mar-2020	6	Document status no longer confidential
15-Dec-2020	7	Updated metadata
13-Apr-2021	8	Fixed issues with <a href="#">Figure 2: VL53L1 pinout (bottom view)</a> , <a href="#">Figure 3: VL53L1 schematic</a> , and <a href="#">Figure 4: VL53L1 system functional description</a>
14-Apr-2021	9	Updated metadata
12-Oct-2021	10	<a href="#">Section 3: Control interface</a> : replaced "camera module" with "Time-of-Flight" sensor.

**IMPORTANT NOTICE – PLEASE READ CAREFULLY**

STMicroelectronics NV and its subsidiaries (“ST”) reserve the right to make changes, corrections, enhancements, modifications, and improvements to ST products and/or to this document at any time without notice. Purchasers should obtain the latest relevant information on ST products before placing orders. ST products are sold pursuant to ST’s terms and conditions of sale in place at the time of order acknowledgement.

Purchasers are solely responsible for the choice, selection, and use of ST products and ST assumes no liability for application assistance or the design of Purchasers’ products.

No license, express or implied, to any intellectual property right is granted by ST herein.

Resale of ST products with provisions different from the information set forth herein shall void any warranty granted by ST for such product.

ST and the ST logo are trademarks of ST. For additional information about ST trademarks, please refer to [www.st.com/trademarks](http://www.st.com/trademarks). All other product or service names are the property of their respective owners.

Information in this document supersedes and replaces information previously supplied in any prior versions of this document.

© 2021 STMicroelectronics – All rights reserved

## X-ON Electronics

Largest Supplier of Electrical and Electronic Components

*Click to view similar products for [Distance Sensor Development Tool](#) category:*

*Click to view products by [SparkFun](#) manufacturer:*

Other Similar products are found below :

[SEN0004](#) [MIKROE-2509](#) [172](#) [DFR0315](#) [SEN0006](#) [SEN0007](#) [SEN0008](#) [SEN0187](#) [SEN0202](#) [SEN0208](#) [DM160234](#) [SEN0143](#) [SEN-13968](#)  
[3316](#) [SEN-08504](#) [SEN-08502](#) [DFR0445](#) [3317](#) [984](#) [SEN0014](#) [SEN0001](#) [SEN0171](#) [3942](#) [979](#) [981](#) [982](#) [985](#) [AFBR-S50MV85G-EK](#)  
[TMF8701-DB](#) [TMF8801-DB](#) [TMF8801-EVM](#) [AD8283CP-EBZ](#) [AD8285CP-EBZ](#) [ADUX1020-EVAL-SDP](#) [SEN0245](#)  
[EVALBGT24LTR22TOBO1](#) [DM160238](#) [MIKROE-3339](#) [MIKROE-3439](#) [MIKROE-1589](#) [MIKROE-1991](#) [MIKROE-2086](#) [MIKROE-3103](#)  
[SECO-RANGEFINDER-GEVK](#) [PIM058](#) [PIM062](#) [PIM373](#) [101020083](#) [101020353](#) [101020532](#)