

Silicon NPN Power Transistor

DESCRIPTION

- High Switching Speed
- High Breakdown Voltage-
: $V_{(BR)CBO} = 1500V(\text{Min})$

APPLICATIONS

- Designed for horizontal deflection output applications.

ABSOLUTE MAXIMUM RATINGS($T_a = 25^\circ\text{C}$)

SYMBOL	PARAMETER	VALUE	UNIT
V_{CBO}	Collector-Base Voltage	1500	V
V_{CEO}	Collector-Emitter Voltage	800	V
V_{EBO}	Emitter-Base Voltage	6	V
I_C	Collector Current-Continuous	25	A
I_{CM}	Collector Current-Pulse	50	A
P_C	Collector Power Dissipation @ $T_C = 25^\circ\text{C}$	250	W
T_J	Junction Temperature	150	$^\circ\text{C}$
T_{stg}	Storage Temperature Range	-55~150	$^\circ\text{C}$

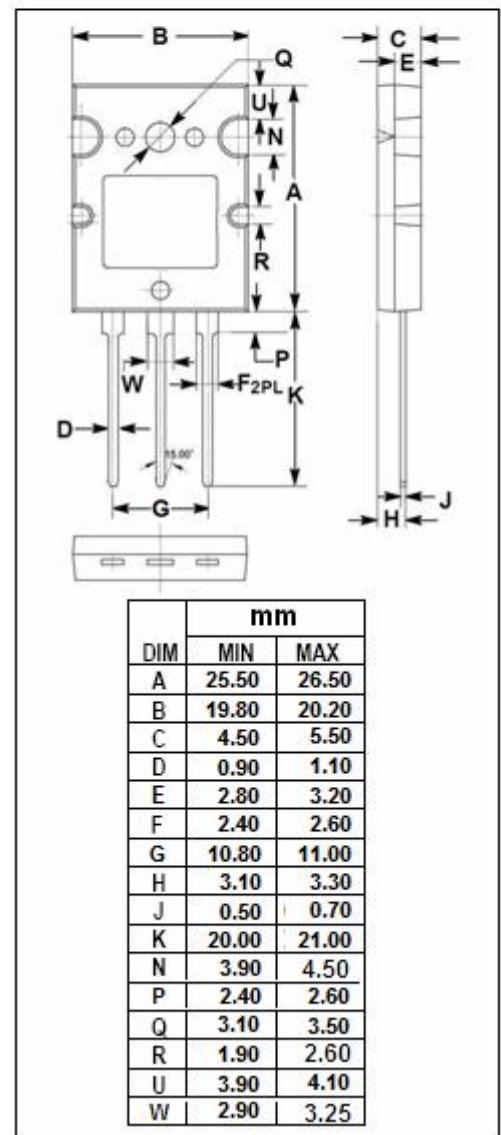
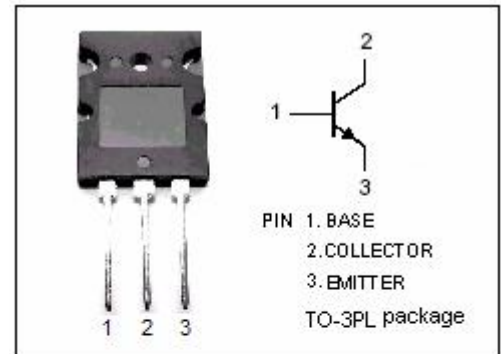

Ordering Information

Product	Package	Packaging
2SC3998T7TL	TO-3PL	Tube



ELECTRICAL CHARACTERISTICS

$T_c=25^\circ\text{C}$ unless otherwise specified

SYMBOL	PARAMETER	CONDITIONS	MIN	TYP.	MAX	UNIT
$V_{CE(SUS)}$	Collector-Emitter Sustaining Voltage	$I_C=10\text{mA}; I_B=0$	800			V
$V_{CE(sat)}$	Collector-Emitter Saturation Voltage	$I_C=20\text{A}; I_B=5\text{A}$			5.0	V
$V_{BE(sat)}$	Base-Emitter Saturation Voltage	$I_C=20\text{A}; I_B=5\text{A}$			1.5	V
I_{CBO}	Collector Cutoff Current	$V_{CB}=800\text{V}; I_E=0$			10	μA
I_{CES}	Collector Cutoff Current	$V_{CE}=1500\text{V}; R_{BE}=0$			1.0	mA
I_{EBO}	Emitter Cutoff Current	$V_{EB}=4\text{V}; I_C=0$			1.0	mA
h_{FE-1}	DC Current Gain	$I_C=1\text{A}; V_{CE}=5\text{V}$	8		30	
h_{FE-2}	DC Current Gain	$I_C=20\text{A}; V_{CE}=5\text{V}$	4		8	
t_{stg}	Storage Time	$I_C=12\text{A}, I_{B1}=2.4\text{A}; I_{B2}=-4.8\text{A}$			3.0	μs
t_f	Fall Time				0.2	μs

X-ON Electronics

Largest Supplier of Electrical and Electronic Components

Click to view similar products for [Bipolar Transistors - BJT category](#):

Click to view products by [SPS manufacturer](#):

Other Similar products are found below :

[619691C](#) [MCH4017-TL-H](#) [MJ15024/WS](#) [MJ15025/WS](#) [BC546/116](#) [BC556/FSC](#) [BC557/116](#) [BSW67A](#) [HN7G01FU-A\(T5L,F,T](#)
[NJVMJD148T4G](#) [NSVMMBT6520LT1G](#) [NTE187A](#) [NTE195A](#) [NTE2302](#) [NTE2330](#) [NTE2353](#) [NTE316](#) [IMX9T110](#) [NTE63](#) [NTE65](#)
[C4460](#) [SBC846BLT3G](#) [2SA1419T-TD-H](#) [2SA1721-O\(TE85L,F\)](#) [2SA1727TLP](#) [2SA2126-E](#) [2SB1202T-TL-E](#) [2SB1204S-TL-E](#) [2SC5488A-](#)
[TL-H](#) [2SD2150T100R](#) [SP000011176](#) [FMC5AT148](#) [2N2369ADCSM](#) [2SB1202S-TL-E](#) [2SC2412KT146S](#) [2SC4618TLN](#) [2SC5490A-TL-H](#)
[2SD1816S-TL-E](#) [2SD1816T-TL-E](#) [CMXT2207 TR](#) [CPH6501-TL-E](#) [MCH4021-TL-E](#) [BC557B](#) [TTC012\(Q\)](#) [BULD128DT4](#) [JANTX2N3810](#)
[Jantx2N5416](#) [US6T6TR](#) [KSF350](#) [068071B](#)