

N-Channel Super Junction Power MOSFET

Description

SM140R50C is power MOSFET using advanced super junction technology that can realize very low on-resistance and gate charge. It will provide much high efficiency by using optimized charge coupling technology. These user friendly devices give an advantage of low EMI to designers as well as low switching loss.

I_D	24A
V_{DSS}	500V
$R_{dson (max.)}$	$0.14\Omega (V_{GS}=10V, I_D=12A)$
Q_g	70nC

General Features

- 24A, 500V, $R_{DS(on)(max)} = 0.14\Omega @ V_{GS}=10V$
- Low Gate charge
- Low C_{rss}
- Fast Switching
- Improved dv/dt Capability

Application

- Power switching application
- Hard switched and high frequency circuits
- Uninterruptible power supply

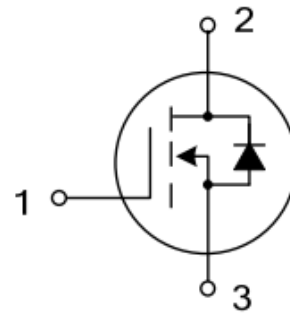

1.Gate 2.Drain 3.Source



TO-220



TO-220F

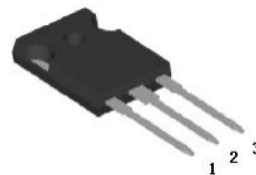

TO-247

Order Information

Order Information	Marking ID	Package	Packing Type Supplied As
SM140R50CT2TL	140R50C	TO220F-3L	1000 units on Box, 5000 units on Carton
SM140R50CT1TL	140R50C	TO220-3L	1000 units on Box, 5000 units on Carton
SM140R50CT8TL	140R50C	TO247-3L	450 units on Box, 2250 units on Carton

Absolute Maximum Ratings Ta=25 °C unless otherwise noted

Parameter	Symbol	Value	Unit
Drain-source Voltage	V _{DS}	500	V
Gate-source Voltage	V _{GS}	±30	V
Continuous Drain Current(Ta=25°C)	I _D	24	A
Drain Current-Pulsed	I _{DM}	70	A
Total Dissipation (Ta=25°C)	TO247	312	W
	TO220	168	
	TO220F	35	
Junction Temperature	T _J	150	°C
Storage Temperature	T _{STG}	-65 to 150	°C
Single Pulse Avalanche Energy	E _{AS}	485	mJ
ESD HBM(Human Body Mode)		≥2000	V
ESD MM(Machine Mode)		≥200	V

Electrical Characteristics Ta = 25°C

PARAMETER	Symbol	Test Condition	MIN	Typ	MAX	UNIT
Drain-source Breakdown Voltage	BV _{DSS}	V _{GS} =0V, I _D =250μA	500			V
Gate Threshold Voltage	V _{GS(TH)}	V _{GS} =V _{DS} , I _D =250μA	2.5		4.5	V
Drain-source Leakage Current	I _{DSS}	V _{DS} =500V, V _{GS} =0V			1	uA
Drain-Source Diode Forward Voltage	V _{SD}	V _{GS} =0V, I _S =24A			1.5	V
Gate-body Leakage Current (V _{DS} = 0)	I _{GSS}	V _{GS} =±30V			±100	nA
Forward Transconductance	G _{FS}	V _{DS} =10V I _D =24A	8			S
Static Drain-source On Resistance	R _{DS(ON)}	V _{GS} =10V, I _D =12A		0.11	0.14	Ω

Note: Using continuously under heavy loads (e.g. the application of high temperature/current/voltage and the significant in temperature etc.) may cause this product to decrease in the reliability significantly even if the operating conditions (i.e. operating temperature/current/voltage, etc.) are within the absolute maximum ratings

Thermal Characteristics Ta=25°C

PARAMETER		Symbol	TYP	MAX	UNIT
Maximum Junction-to-case	TO220F,TO220	R _{QJC}		1.56	°C/W
	TO-247			0.3	
Maximum Junction-to-Ambient	TO220F,TO220	R _{QJA}		80	
	TO247			40	

Note1: Ensure that the channel temperature does not exceed 150°C

Note2: V_{DD}=50V, T_{ch}=25 °C(initial), I_{AS}=24A, R_G=25Ω

Note3: This transistor is sensitive to electrostatic and should be handled with care

Dynamic Characteristics Ta = 25 °C

PARAMETER	Symbol	Test Condition	MIN	TYP	MAX	UNIT
Input Capacitance	C _{iss}	V _{DS} =25V, V _{GS} =0V, f=1.0MHZ		1440		pF
output Capacitance	C _{oss}			370		pF
Reverse Transfer Capacitance	C _{rss}			11		pF

Switching Characteristics Ta=25 °C

PARAMETER	Symbol	Test Condition	MIN	TYP	MAX	UNIT
Turn-On Delay Time	T _{d(on)}	V _{DS} =400V, I _D =24A, V _{GS} =10V, R _G =25Ω		15		nS
Turn-On Rise Time	T _r			11		nS
Turn-Off Delay Time	T _{d(off)}			110		nS
Turn-Off Rise Time	T _f			9		nS
Total Gate Charge	Q _g	V _{DS} =400V, I _D =12A, V _{GS} =10V		70		nC
Gate-Source Charge	Q _{gs}			7.8		nC
Gate-Drain Charge	Q _{gd}			9		nC

Drain-Source Diode Maximum Ratings and Characteristics Ta=25 °C

PARAMETER	Symbol	Test Condition	MIN	TYP	MAX	UNIT
Max. Diode Forward Current	I _s	Integral Reverse P-N Junction Diode in the MOSFET			24	A
Pulsed Source Current	I _{sm}				70	
Diode Forward Voltage	V _{SD}	V _{GS} =0V, I _s =24A			1.5	V
Reverse Recovery Time	T _{rr}	V _{GS} =0V, I _s =24A, dI _F /dt=100A/μs		475		nS
Reverse Recovery Charge	Q _{rr}				5.8	

Test Circuit

Gate Charge Test Circuit & Waveform

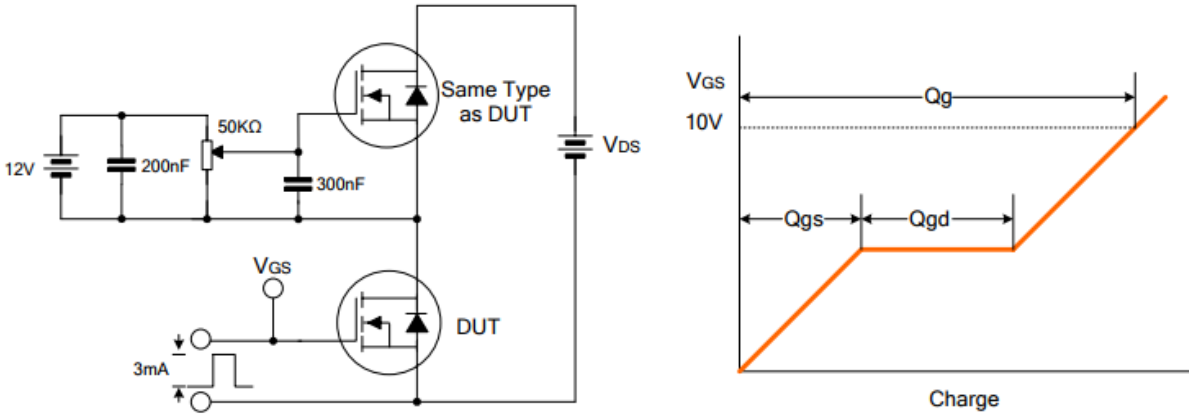

Resistive Switching Test Circuit & Waveform

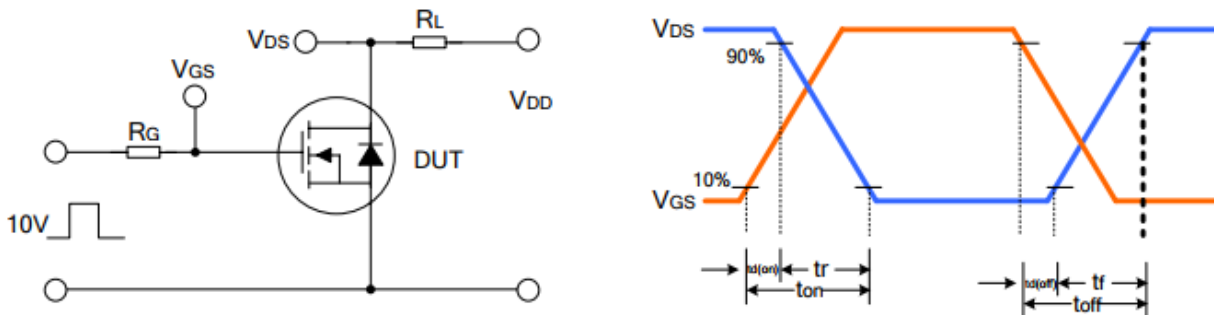

Unclamped Inductive Switching Test Circuit & Waveform

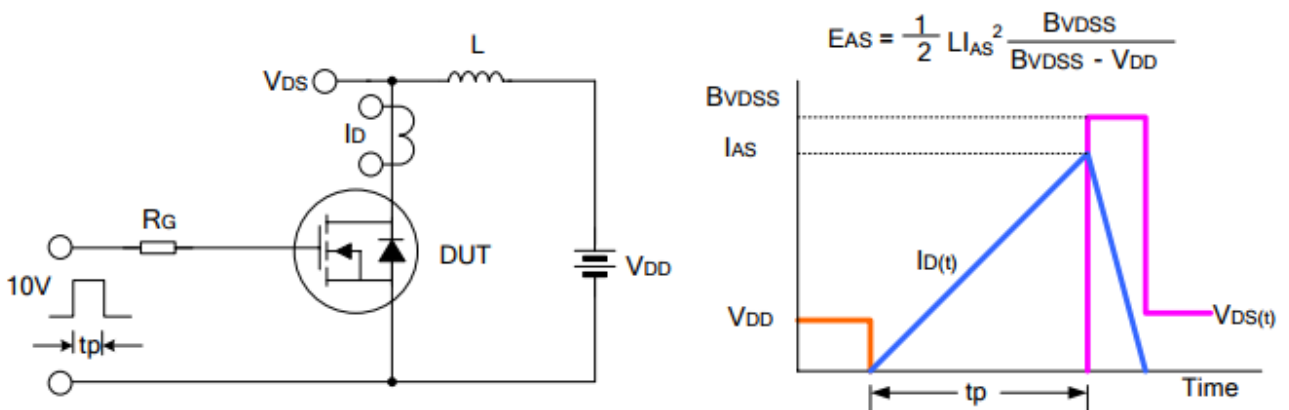

Typical Characteristics Curve

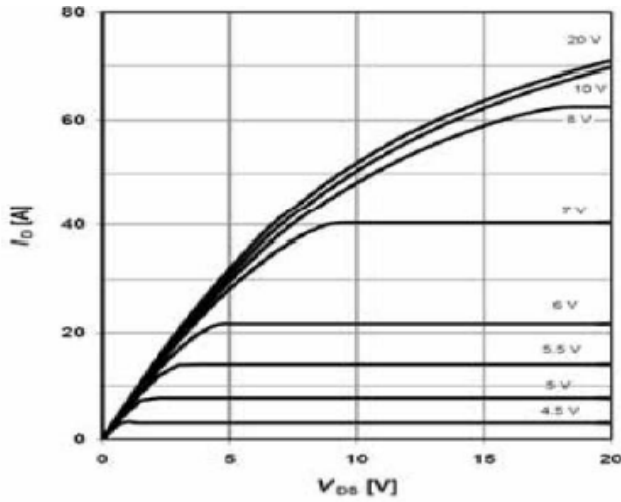

Figure 1: Output Characteristics

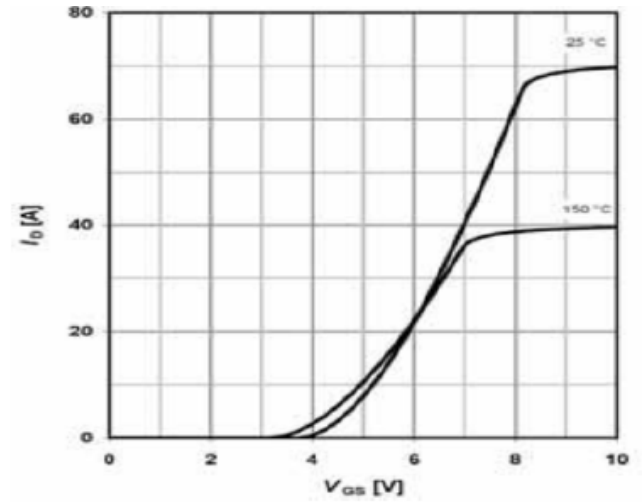

Figure 2: Transfer Characteristics

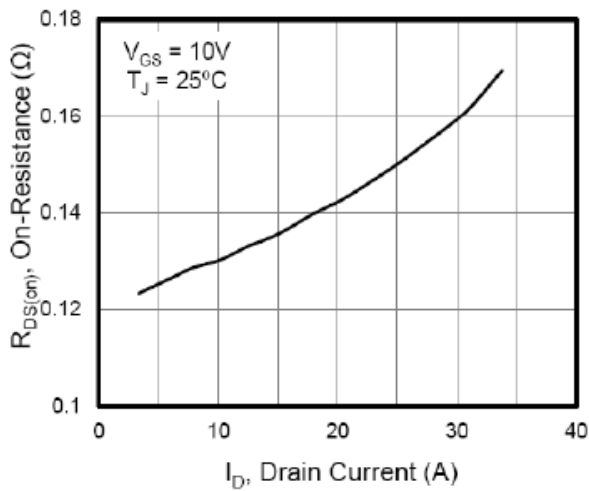

Figure 3: On Resistance Vs Drain Current

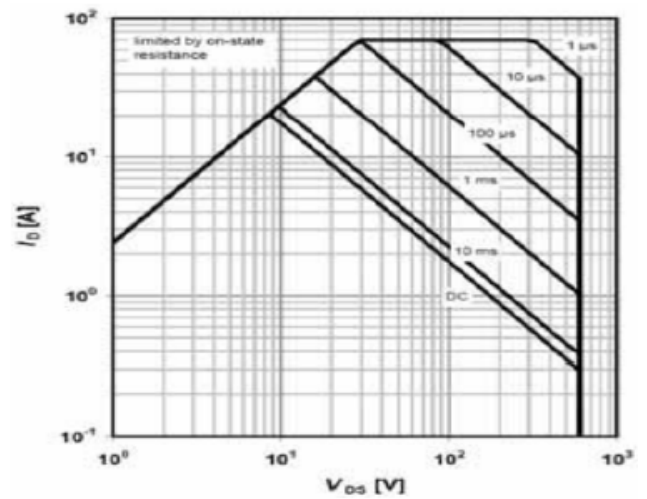

Figure 4: Safe Operating Area

Operating Area

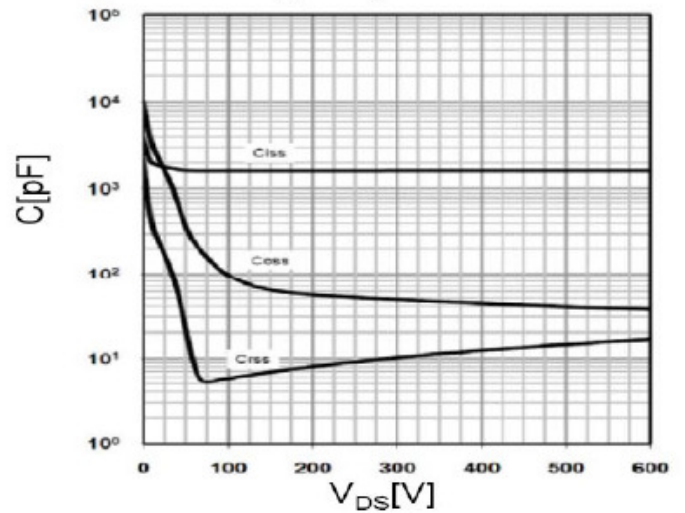
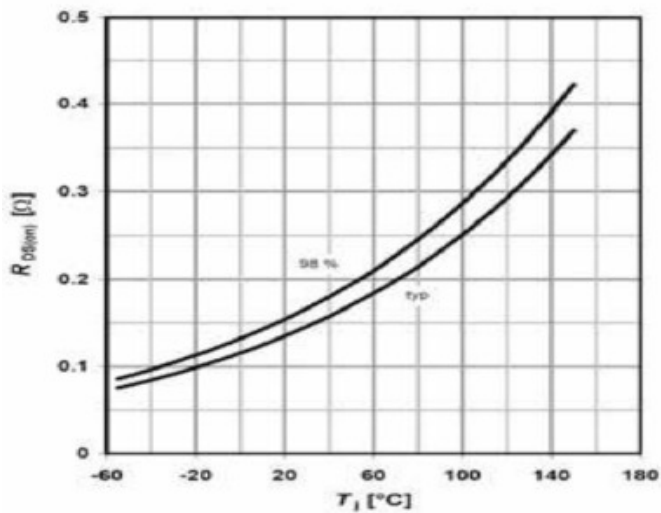

Figure5: On Resistance Vs Junction Temperature Characteristics

Figure6: Capacitance

Typical Characteristics Curve

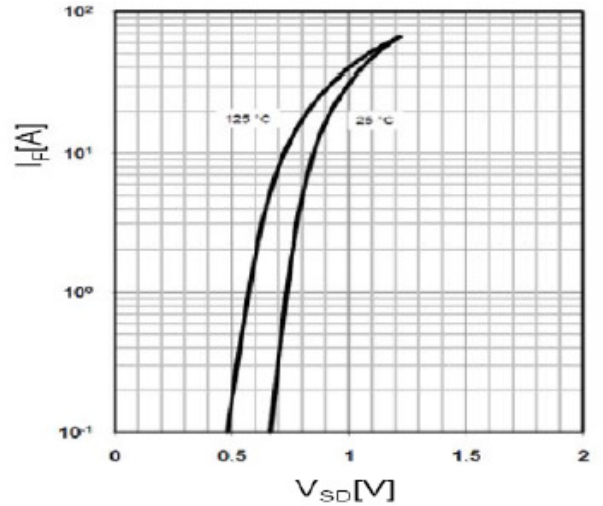
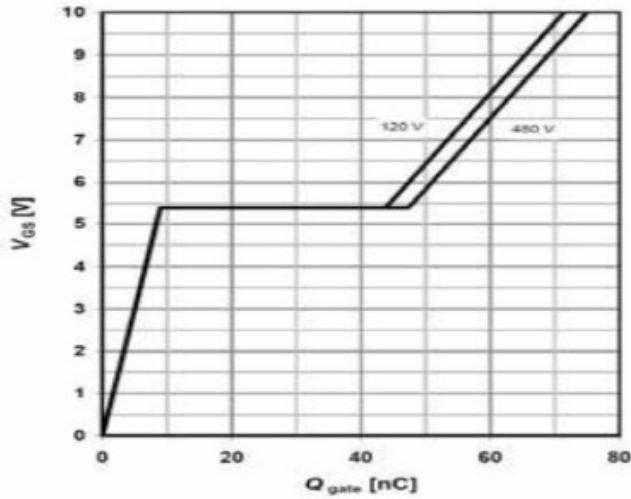

Figure7: Gate Charge Waveform

Figure8: Source-Drain

Diode Forward Voltage

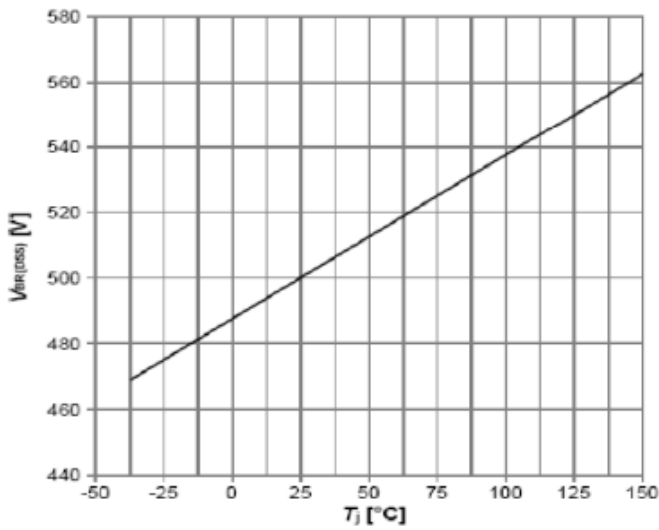
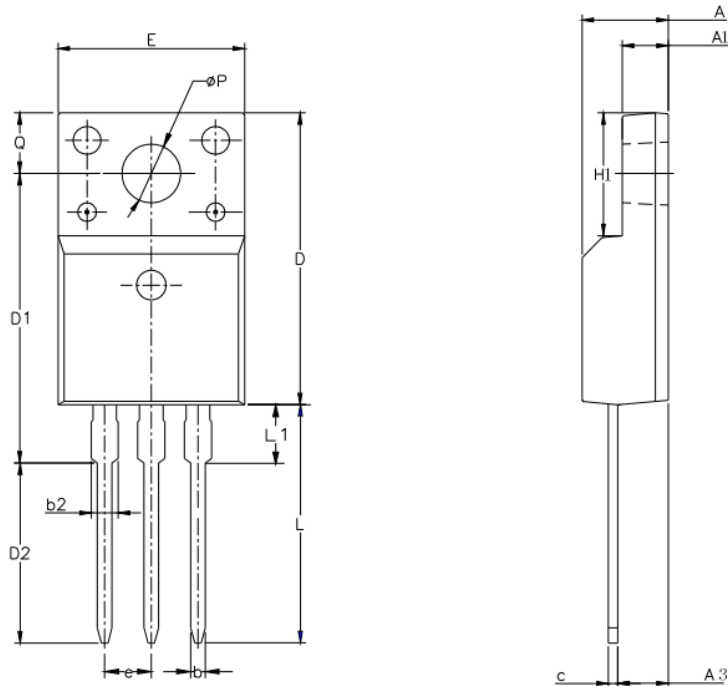

Figure9: Breakdown Voltage Vs Junction Temperature

Note: The above characteristics curves are presented for reference only and not guaranteed by production test unless otherwise noted

Outline Information (TO220F-3L)



SYMBOL	MIN	NOM	MAX
A	4.42	4.70	5.02
A1	2.30	2.54	2.80
A3	2.50	2.76	3.10
b	0.70	0.80	0.90
b2	—	—	1.47
c	0.35	0.50	0.65
D	15.25	15.87	16.25
D1	15.30	15.75	16.30
D2	9.30	9.80	10.30
E	9.73	10.16	10.36
e	2.54BCS		
H1	6.40	6.68	7.00
L	12.48	12.98	13.48
L1	/	/	3.50
ϕP	3.00	3.18	3.40
Q	3.05	3.30	3.55

Outline Information (TO220-3L)

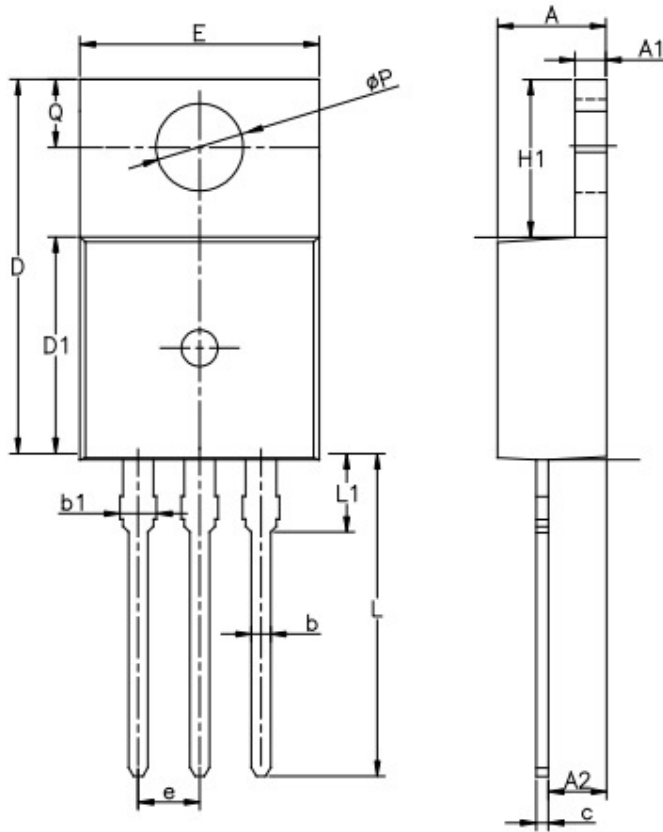

SYMBOL	MIN	NOM	MAX
A	4.30	4.50	4.70
A1	1.00	1.30	1.50
A2	1.80	2.40	2.80
b	0.60	0.80	1.00
b1	1.00	—	1.60
c	0.30	—	0.70
D	15.10	15.70	16.10
D1	8.10	9.20	10.00
E	9.60	9.90	10.40
e	2.54BSC		
H1	6.10	6.50	7.00
L	12.60	13.08	13.60
L1	—	—	3.95
ΦP	3.40	3.70	3.90
Q	2.60	—	3.20

Outline Information (TO247-3L)

UNIT: mm

SYMBOL	MIN	NOM	MAX	SYMBOL	MIN	NOM	MAX
A	4.60		5.15	A1	1.30		1.60
b	2.86		3.26	b1	1.86		2.26
b2		1.20		c		0.50	
D	19.00		21.00	E	15.45		15.75
E1	12.00		13.06	e		5.45	
L	14.00		14.60	L1	5.20		5.88
L2	24.00		24.40	L3	10.00		10.60
P		3.50		Q	2.30		2.70

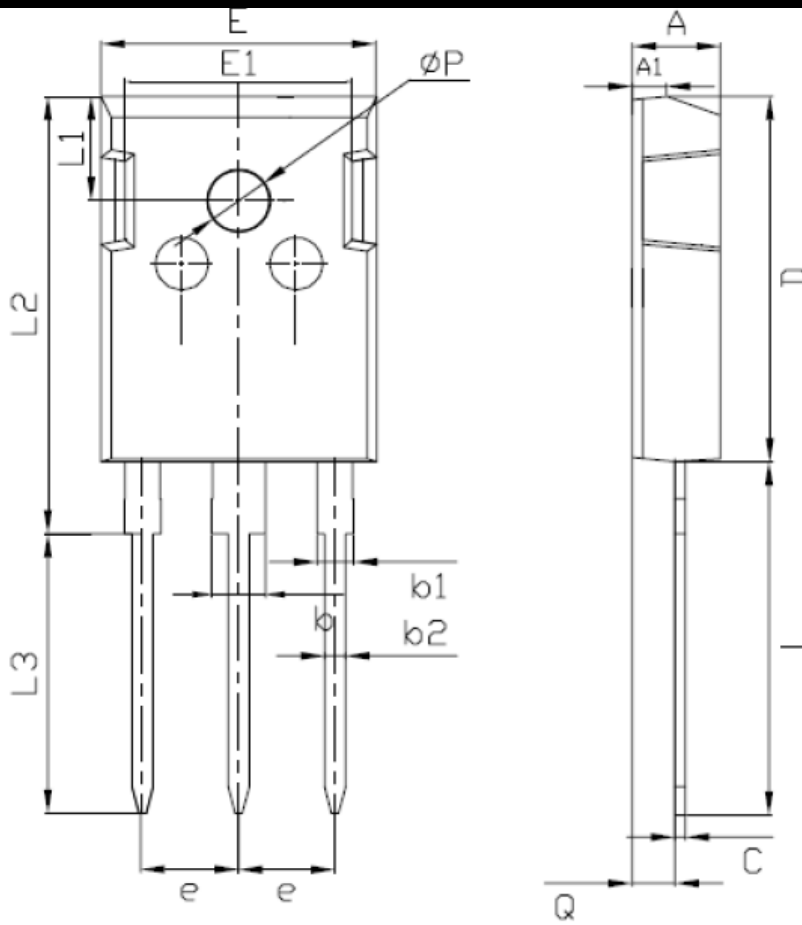

X-ON Electronics

Largest Supplier of Electrical and Electronic Components

Click to view similar products for [MOSFET](#) category:

Click to view products by [SPS](#) manufacturer:

Other Similar products are found below :

[614233C](#) [648584F](#) [MCH3443-TL-E](#) [MCH6422-TL-E](#) [FDPF9N50NZ](#) [FW216A-TL-2W](#) [FW231A-TL-E](#) [APT5010JVR](#) [NTNS3A92PZT5G](#)
[IRF100S201](#) [JANTX2N5237](#) [2SK2464-TL-E](#) [2SK3818-DL-E](#) [FCA20N60_F109](#) [FDZ595PZ](#) [STD6600NT4G](#) [FSS804-TL-E](#) [2SJ277-DL-E](#)
[2SK1691-DL-E](#) [2SK2545\(Q,T\)](#) [D2294UK](#) [405094E](#) [423220D](#) [MCH6646-TL-E](#) [TPCC8103,L1Q\(CM](#) [367-8430-0972-503](#) [VN1206L](#)
[424134F](#) [026935X](#) [051075F](#) [SBVS138LT1G](#) [614234A](#) [715780A](#) [NTNS3166NZT5G](#) [751625C](#) [873612G](#) [IRF7380TRHR](#)
[IPS70R2K0CEAKMA1](#) [RJK60S3DPP-E0#T2](#) [RJK60S5DPK-M0#T0](#) [APT5010JVFR](#) [APT12031JFLL](#) [APT12040JVR](#) [DMN3404LQ-7](#)
[NTE6400](#) [JANTX2N6796U](#) [JANTX2N6784U](#) [JANTXV2N5416U4](#) [SQM110N05-06L-GE3](#) [SIHF35N60E-GE3](#)