

## N-Channel Super Junction Power MOSFET

### Description

SM360R65C is power MOSFET using advanced super junction technology that can realize very low on-resistance and gate charge. It will provide much high efficiency by using optimized charge coupling technology. These user friendly devices give an advantage of low EMI to designers as well as low switching loss.

$I_D$	13A
$V_{DSS}$	650V
$R_{dson (max.)}$	$0.36\Omega (V_{GS}=10V, I_D=6.5A)$
$Q_g$	23nC

### General Features

- 13A, 650V,  $R_{DS(on)(max)} = 0.36\Omega @ V_{GS}=10V$
- Low Gate charge
- Low  $C_{rss}$
- Fast Switching
- Improved  $dv/dt$  Capability

### Application

- Power switching application
- Hard switched and high frequency circuits
- Uninterruptible power supply

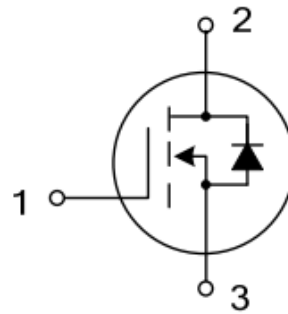

1.Gate 2.Drain 3.Source



TO-220



TO-220F

**Order Information**

Order Information	Marking ID	Package	Packing Type Supplied As
SM360R65CT2TL	360R65C	TO220F-3L	1000 units on Box, 5000 units on Carton
SM360R65CT1TL	360R65C	TO220-3L	1000 units on Box, 5000 units on Carton

**Absolute Maximum Ratings Ta=25 °C unless otherwise noted**

Parameter	Symbol	Value	Unit
Drain-source Voltage	V <sub>DS</sub>	650	V
Gate-source Voltage	V <sub>GS</sub>	±30	V
Continuous Drain Current(Ta=25°C)	I <sub>D</sub>	13	A
Drain Current-Pulsed	I <sub>DM</sub>	52	A
Total Dissipation (Ta=25°C)	TO220	87	W
	TO220F	32	
Junction Temperature	T <sub>J</sub>	150	°C
Storage Temperature	T <sub>STG</sub>	-65 to 150	°C
Single Pulse Avalanche Energy	E <sub>AS</sub>	165	mJ
ESD HBM(Human Body Mode)		≥2000	V
ESD MM(Machine Mode)		≥200	V

**Electrical Characteristics Ta = 25°C**

PARAMETER	Symbol	Test Condition	MIN	Typ	MAX	UNIT
Drain-source Breakdown Voltage	BV <sub>DSS</sub>	V <sub>GS</sub> =0V, I <sub>D</sub> =250μA	650			V
Gate Threshold Voltage	V <sub>GS(TH)</sub>	V <sub>GS</sub> =V <sub>DS</sub> , I <sub>D</sub> =250μA	2.0		4.0	V
Drain-source Leakage Current	I <sub>DSS</sub>	V <sub>DS</sub> =650V, V <sub>GS</sub> =0V			1	uA
Drain-Source Diode Forward Voltage	V <sub>SD</sub>	V <sub>GS</sub> =0V, I <sub>S</sub> =13A			1.5	V
Gate-body Leakage Current (V <sub>DS</sub> = 0)	I <sub>GSS</sub>	V <sub>GS</sub> =±30V			±100	nA
Forward Transconductance	G <sub>FS</sub>	V <sub>DS</sub> =10V I <sub>D</sub> =13A	3			S
Static Drain-source On Resistance	R <sub>DS(ON)</sub>	V <sub>GS</sub> =10V, I <sub>D</sub> =6.5A			0.36	Ω

**Note:** Using continuously under heavy loads (e.g. the application of high temperature/current/voltage and the significant in temperature etc.) may cause this product to decrease in the reliability significantly even if the operating conditions (i.e. operating temperature/current/voltage, etc.) are within the absolute maximum ratings

## Thermal Characteristics Ta=25°C

PARAMETER		Symbol	TYP	MAX	UNIT
Maximum Junction-to-case	TO220F,TO220	R <sub>QJC</sub>		3.9	°C/W
Maximum Junction-to-Ambient	TO220F,TO220	R <sub>QJA</sub>		80	°C/W

**Note1:** Ensure that the channel temperature does not exceed 150°C

**Note2:** V<sub>DD</sub>=50V, T<sub>ch</sub>=25 °C(initial), I<sub>AS</sub>=13A, R<sub>g</sub>=25Ω

**Note3:** This transistor is sensitive to electrostatic and should be handled with care

## Dynamic Characteristics Ta = 25 °C

PARAMETER	Symbol	Test Condition	MIN	TYP	MAX	UNIT
Input Capacitance	C <sub>iss</sub>	V <sub>DS</sub> =25V, V <sub>GS</sub> =0V, f=1.0MHZ		820		pF
output Capacitance	C <sub>oss</sub>			680		pF
Reverse Transfer Capacitance	C <sub>rss</sub>			32		pF

## Switching Characteristics Ta=25 °C

PARAMETER	Symbol	Test Condition	MIN	TYP	MAX	UNIT
Turn-On Delay Time	T <sub>d(on)</sub>	V <sub>DS</sub> =400V, I <sub>D</sub> =13A, V <sub>GS</sub> =10V, R <sub>G</sub> =25Ω		12		nS
Turn-On Rise Time	T <sub>r</sub>			23		nS
Turn-Off Delay Time	T <sub>d(off)</sub>			43		nS
Turn-Off Rise Time	T <sub>f</sub>			22		nS
Total Gate Charge	Q <sub>g</sub>	V <sub>DS</sub> =400V, I <sub>D</sub> =13A, V <sub>GS</sub> =10V		23		nC
Gate-Source Charge	Q <sub>gs</sub>			6		nC
Gate-Drain Charge	Q <sub>gd</sub>			9		nC

## Drain-Source Diode Maximum Ratings and Characteristics Ta=25 °C

PARAMETER	Symbol	Test Condition	MIN	TYP	MAX	UNIT
Max. Diode Forward Current	I <sub>s</sub>	Integral Reverse P-N Junction Diode in the MOSFET			13	A
Pulsed Source Current	I <sub>sm</sub>				52	
Diode Forward Voltage	V <sub>SD</sub>	V <sub>GS</sub> =0V, I <sub>s</sub> =13A			1.5	V
Reverse Recovery Time	T <sub>rr</sub>	V <sub>GS</sub> =0V, I <sub>s</sub> =13A, dI <sub>F</sub> /dt=100A/μs		250		nS
Reverse Recovery Charge	Q <sub>rr</sub>				1.8	

## Test Circuit

### Gate Charge Test Circuit & Waveform

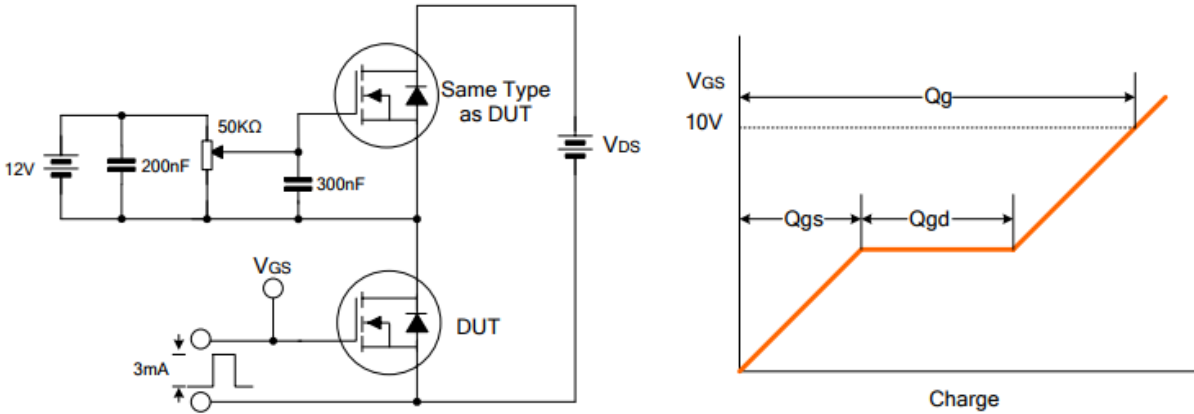

### Resistive Switching Test Circuit & Waveform

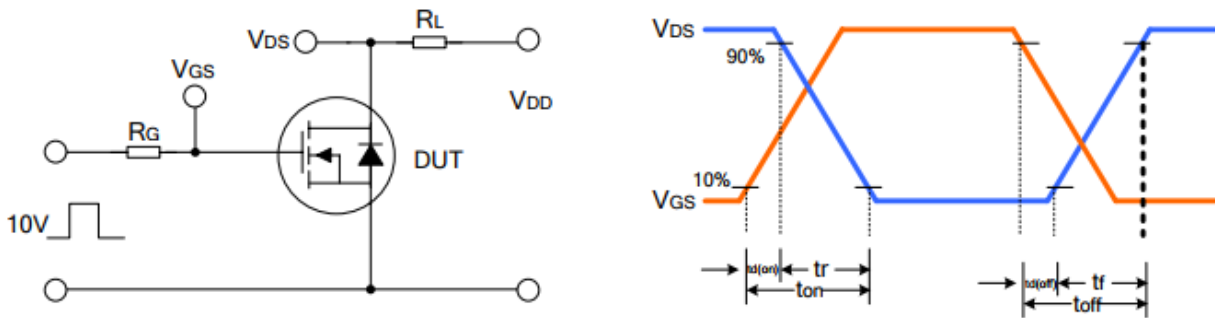

### Unclamped Inductive Switching Test Circuit & Waveform

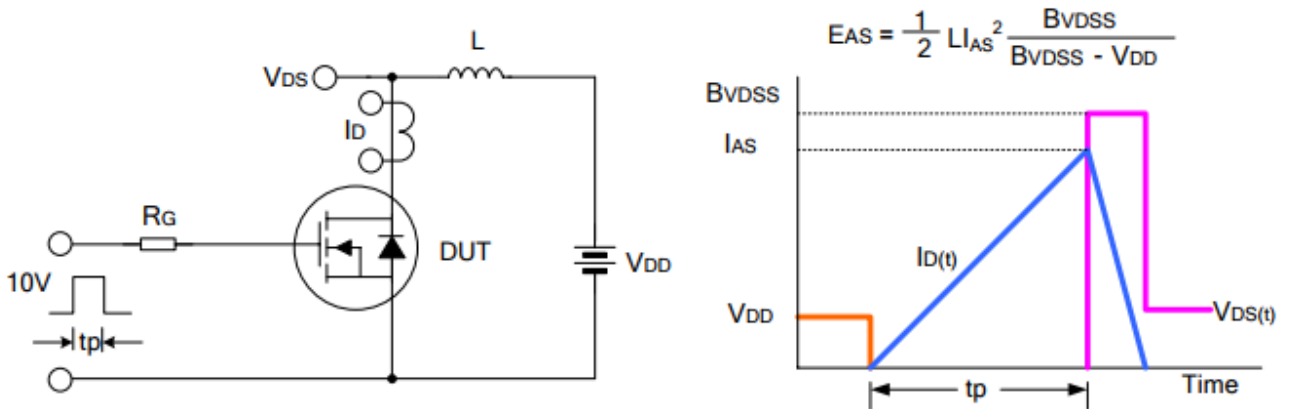

## Typical Characteristics Curve

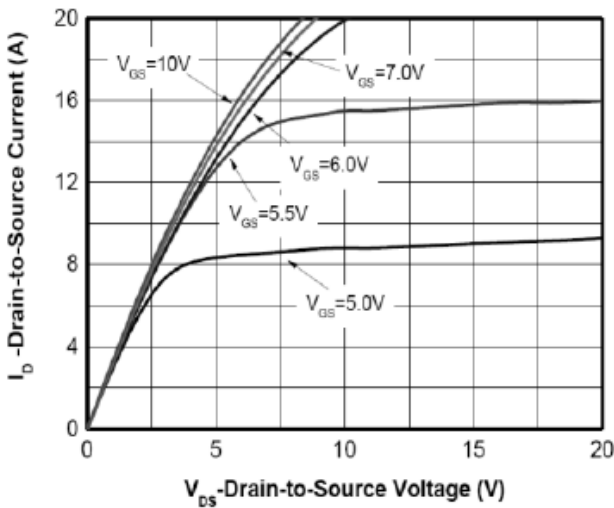

Figure 1: Output Characteristics

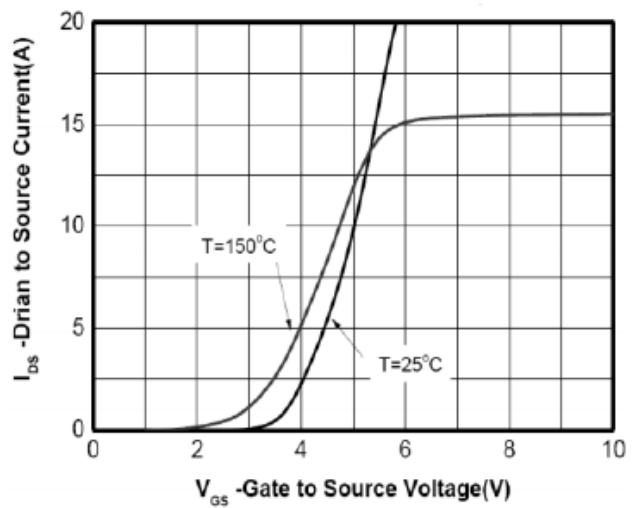

Figure 2: Transfer Characteristics

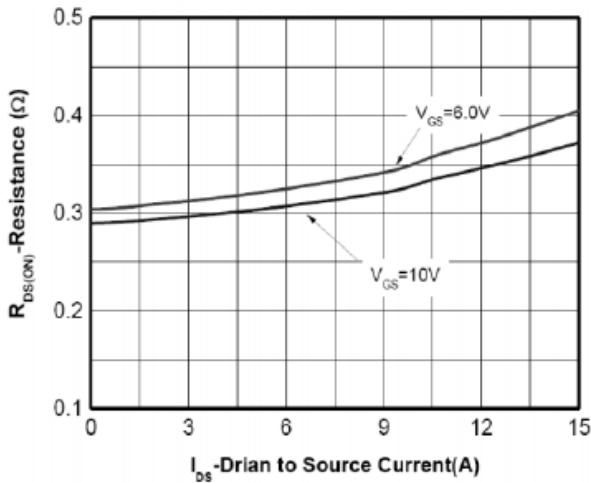

Figure 3: On Resistance Vs Drain Current

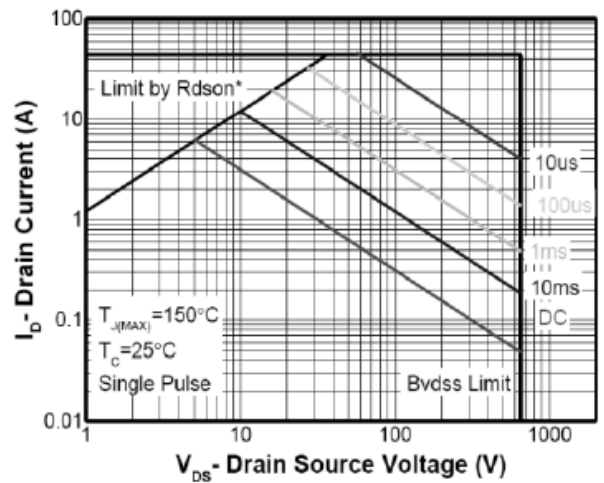

Figure 4: Safe Operating Area

### Operating Area

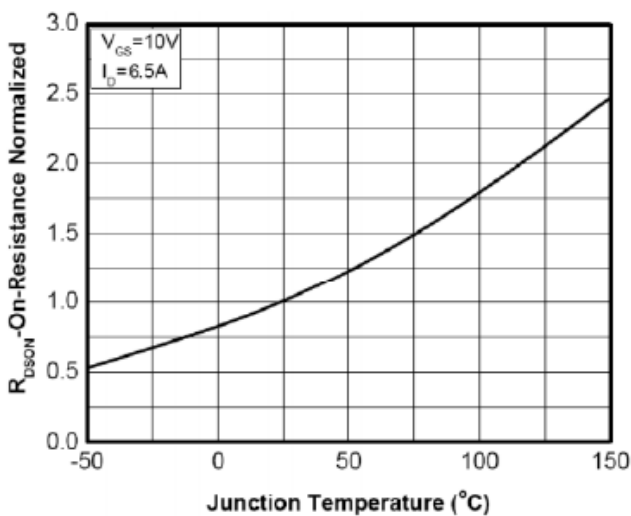

Figure 5: On Resistance Vs Junction Temperature

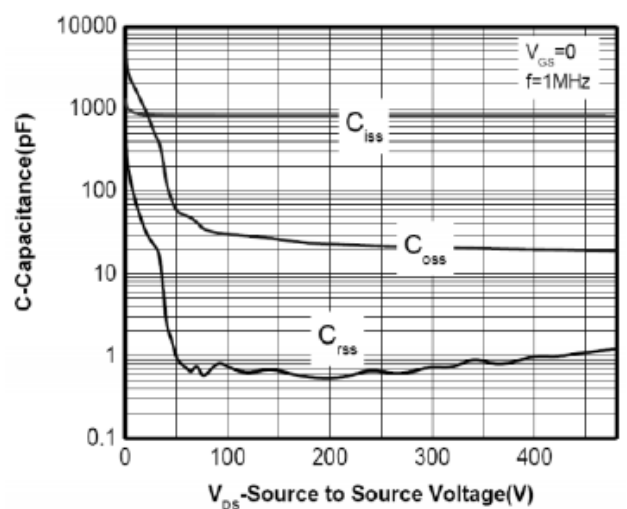

Figure 6: Capacitance

## Characteristics

### Typical Characteristics Curve

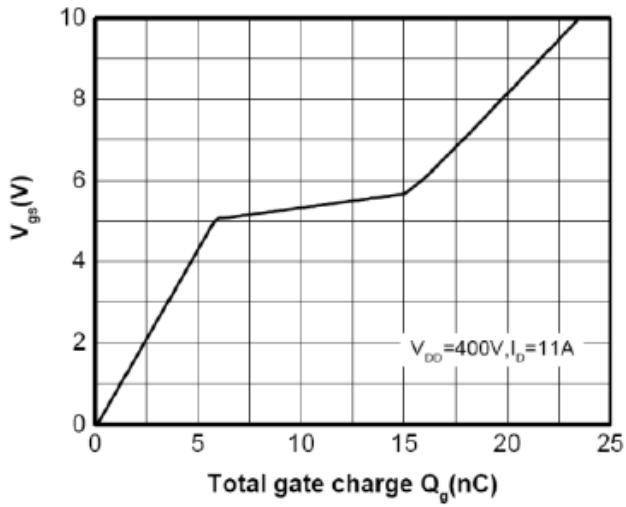

Figure7: Gate Charge Waveform

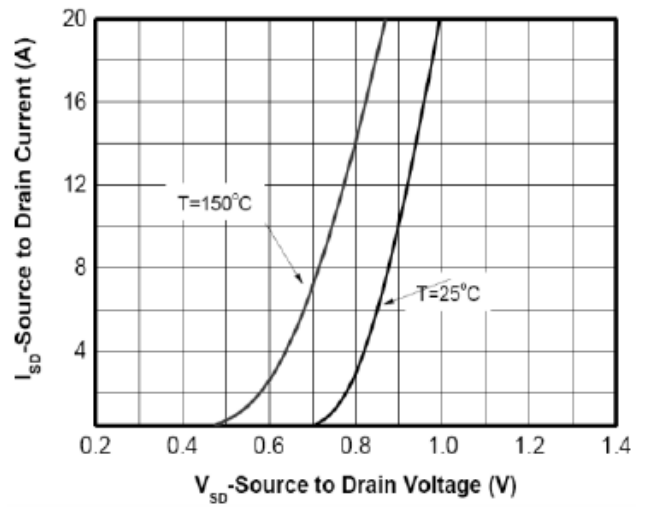

Figure8: Source-Drain

### Diode Forward Voltage

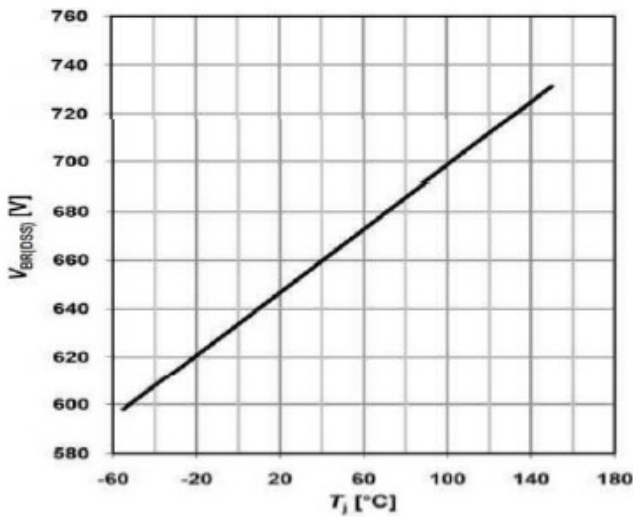
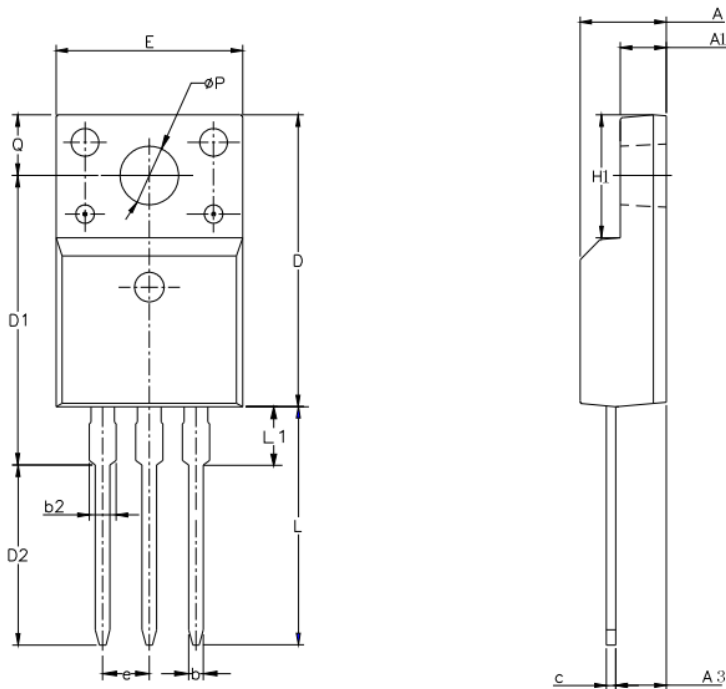

Figure9: Breakdown Voltage Vs Junction Temperature

**Note:** The above characteristics curves are presented for reference only and not guaranteed by production test unless otherwise noted

## Outline Information (TO220F-3L)



SYMBOL	MIN	NOM	MAX
A	4.42	4.70	5.02
A1	2.30	2.54	2.80
A3	2.50	2.76	3.10
b	0.70	0.80	0.90
b2	—	—	1.47
c	0.35	0.50	0.65
D	15.25	15.87	16.25
D1	15.30	15.75	16.30
D2	9.30	9.80	10.30
E	9.73	10.16	10.36
e	2.54BCS		
H1	6.40	6.68	7.00
L	12.48	12.98	13.48
L1	/	/	3.50
$\phi P$	3.00	3.18	3.40
Q	3.05	3.30	3.55

## Outline Information (TO220-3L)

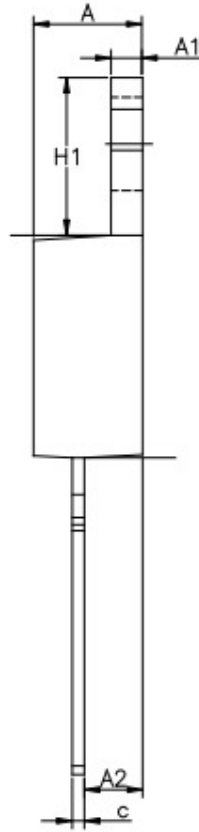
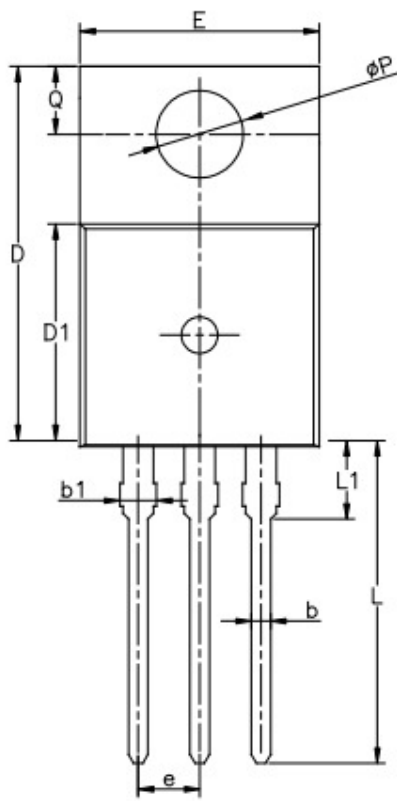

SYMBOL	MIN	NOM	MAX
A	4.30	4.50	4.70
A1	1.00	1.30	1.50
A2	1.80	2.40	2.80
b	0.60	0.80	1.00
b1	1.00	—	1.60
c	0.30	—	0.70
D	15.10	15.70	16.10
D1	8.10	9.20	10.00
E	9.60	9.90	10.40
e	2.54BSC		
H1	6.10	6.50	7.00
L	12.60	13.08	13.60
L1	—	—	3.95
$\phi P$	3.40	3.70	3.90
Q	2.60	—	3.20



## X-ON Electronics

Largest Supplier of Electrical and Electronic Components

*Click to view similar products for [MOSFET](#) category:*

*Click to view products by [SPS](#) manufacturer:*

Other Similar products are found below :

[614233C](#) [648584F](#) [MCH3443-TL-E](#) [MCH6422-TL-E](#) [FDPF9N50NZ](#) [FW216A-TL-2W](#) [FW231A-TL-E](#) [APT5010JVR](#) [NTNS3A92PZT5G](#)  
[IRF100S201](#) [JANTX2N5237](#) [2SK2464-TL-E](#) [2SK3818-DL-E](#) [FCA20N60\\_F109](#) [FDZ595PZ](#) [STD6600NT4G](#) [FSS804-TL-E](#) [2SJ277-DL-E](#)  
[2SK1691-DL-E](#) [2SK2545\(Q,T\)](#) [D2294UK](#) [405094E](#) [423220D](#) [MCH6646-TL-E](#) [TPCC8103,L1Q\(CM](#) [367-8430-0972-503](#) [VN1206L](#)  
[424134F](#) [026935X](#) [051075F](#) [SBVS138LT1G](#) [614234A](#) [715780A](#) [NTNS3166NZT5G](#) [751625C](#) [873612G](#) [IRF7380TRHR](#)  
[IPS70R2K0CEAKMA1](#) [RJK60S3DPP-E0#T2](#) [RJK60S5DPK-M0#T0](#) [APT5010JVFR](#) [APT12031JFLL](#) [APT12040JVR](#) [DMN3404LQ-7](#)  
[NTE6400](#) [JANTX2N6796U](#) [JANTX2N6784U](#) [JANTXV2N5416U4](#) [SQM110N05-06L-GE3](#) [SIHF35N60E-GE3](#)