

## 3A Wide Input 500kHz Synchronous Step-Down Converter

### FEATURES

- 4.5V to 16V Wide Input Voltage Range
- Max 3A Output Current, Up to 96% Efficiency
- Excellent Line and Load Transient Response
- Over Current Protection with Hiccup-Mode
- Inrush Current Limit and Soft Start circuit
- 0.8V Reference Voltage
- -40°C to +85°C Temperature Range
- Available in SOT23-6 Package

### GENERAL DESCRIPTION

The SP1471 is a fully integrated, high efficiency 3A synchronous rectified step-down converter.

The SP1471 operates at high efficiency over a wide output current load range.

This device offers two operation modes, PWM control and PFM Mode switching control, which allows a high efficiency over the wider range of the load.

The SP1471 requires a minimum number of readily available standard external components and is available in an 6-pin SOT23 ROHS compliant package.

### TYPICAL APPLICATION CIRCUIT

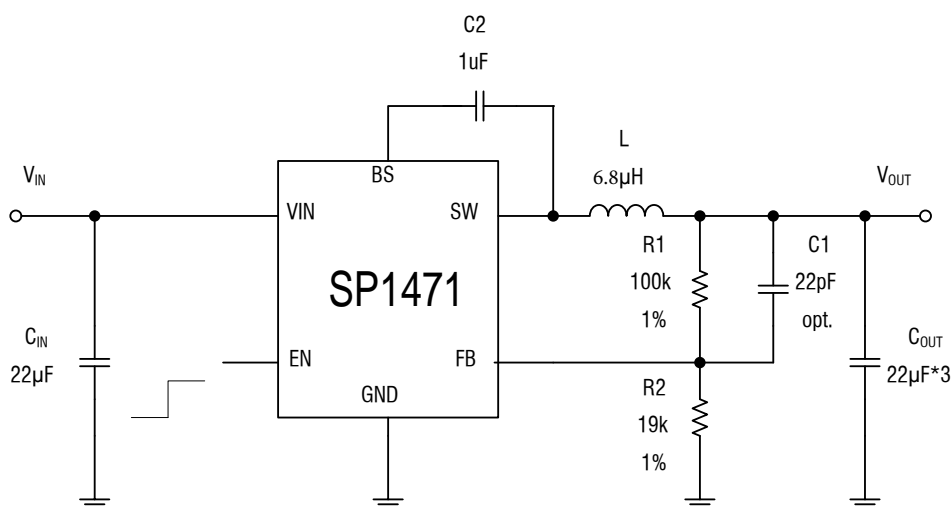

## FUNCTIONAL BLOCK DIAGRAM

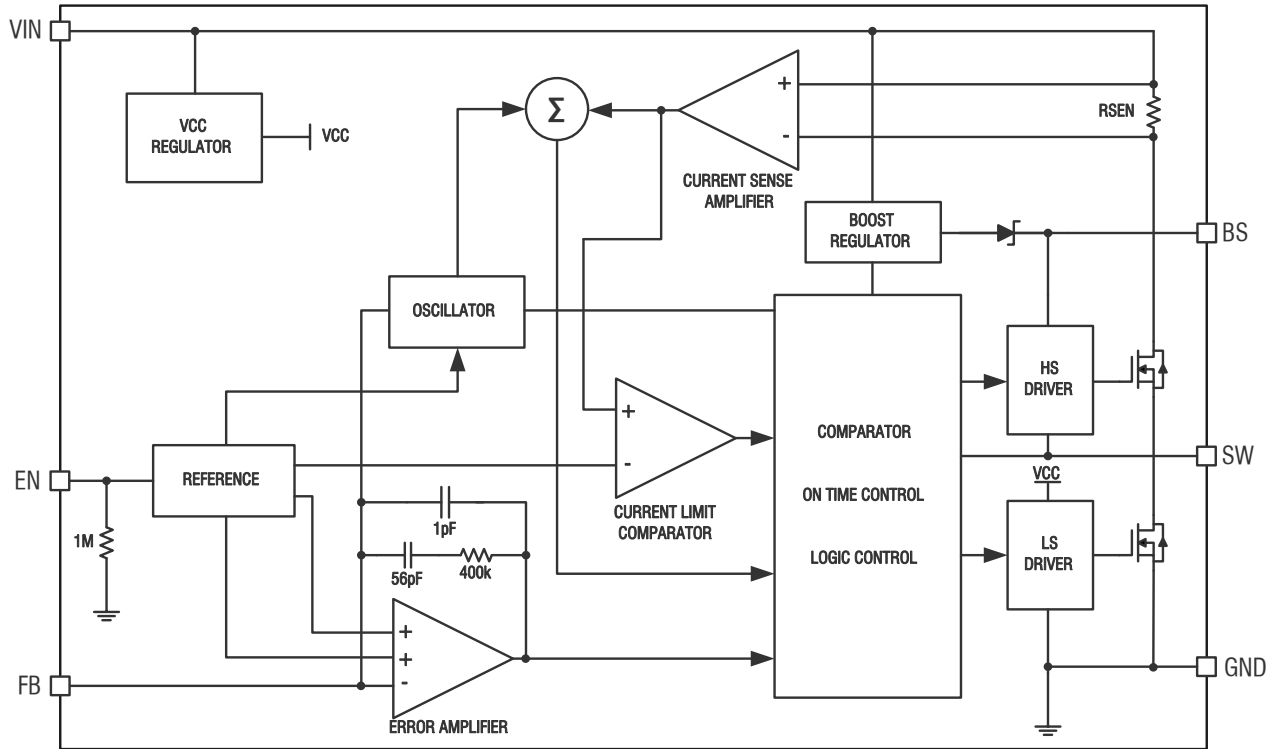

## PIN CONFIGURATION

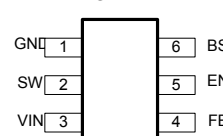
|  | Order Part Number       | Package               |
|--|-------------------------|-----------------------|
| <p><b>TOP VIEW</b></p>  <p>6-LEAD PLASTIC SOT-23<br/> <math>T_{JMAX} = 150^{\circ}\text{C}</math>, <math>\theta_{JA} = 170^{\circ}\text{C/W}</math>, <math>\theta_{JC} = 130^{\circ}\text{C/W}</math></p> | <p><b>SP1471SRL</b></p> | <p><b>SOT23-6</b></p> |

## PIN DESCRIPTIONS

| Pin Name | Pin Number | Description  |
|----------|------------|--|
| GND      | 1          | Analog ground pin.   |
| SW       | 2          | Switching Pin.   |
| VIN      | 3          | Power supply Pin   |
| FB       | 4          | Adjustable version feedback input. Connect FB to the center point of the external resistor divider   |
| EN       | 5          | Drive this pin to a logic-high to enable the IC. Drive to a logic-low to disable the IC and enter micro-power shutdown mode. For automatic start-up, connect EN to VIN using a 200k $\Omega$ resistor. |
| BS       | 6          | Bootstrap. A capacitor connected between SW and BS pins is required to form a floating supply across the high-side switch driver.  |

## ABSOLUTE MAXIMUM RATINGS

Input Supply Voltage.....-0.3V to 17V  
 EN Voltages.....-0.3V to 6V  
 FB Voltages.....-0.3V to 6V  
 SW Voltage.....-0.3V to (V<sub>IN</sub>+0.5V)  
 BS Voltage.....(V<sub>SW</sub>-0.3V) to (V<sub>SW</sub>+5V)  
 Power Dissipation.....0.6W  
 Thermal Resistance  $\theta_{JC}$ .....130 $^{\circ}\text{C}/\text{W}$

Thermal Resistance  $\theta_{JA}$ .....170 $^{\circ}\text{C}/\text{W}$   
 Junction Temperature(Note2).....150 $^{\circ}\text{C}$   
 Operating Temperature Range.....-40 $^{\circ}\text{C}$  to 85 $^{\circ}\text{C}$   
 Lead Temperature(Soldering,10s).....300 $^{\circ}\text{C}$   
 Storage Temperature Range.....-65 $^{\circ}\text{C}$  to 150 $^{\circ}\text{C}$   
 ESD HBM(Human Body Mode).....2kV  
 ESD MM(Machine Mode).....200V



## ELECTRICAL CHARACTERISTICS ( $V_{IN}=12V$ , $V_{OUT}=5V$ , $T_A = 25^{\circ}C$ )

| PARAMETER                        | CONDITIONS  | MIN | TYP | MAX | UNIT        |
|----------------------------------|---|-----|-----|-----|-------------|
| Input Voltage Range              |   | 4.5 |     | 16  | V           |
| Supply Current in Operation      | $V_{EN}=3.0V$ , $V_{FB}=2V$                       |     | 0.6 | 0.8 | mA          |
| Supply Current in Shutdown       | $V_{EN} = 0$ or $EN = GND$                        |     | 1   |     | $\mu A$     |
| Regulated Feedback Voltage       | $T_A = 25^{\circ}C$ , $4.5V \leq V_{IN} \leq 16V$ | 780 | 800 | 820 | mV          |
| High-Side Switch On-Resistance   |   |     | 90  |     | m $\Omega$  |
| Low-Side Switch On-Resistance    |   |     | 70  |     | m $\Omega$  |
| High-Side Switch Leakage Current | $V_{EN}=0V$ , $V_{SW}=0V$                         |     |     | 1   | $\mu A$     |
| Low-Side Switch Leakage Current  | $V_{EN}=0V$ , $V_{SW}=12V$                        |     |     | 1   | $\mu A$     |
| Upper Switch Current Limit       | Minimum Duty Cycle                                |     | 4.5 |     | A           |
| Oscillation Frequency            |   | 400 | 500 | 580 | KHz         |
| Maximum Duty Cycle               | $V_{FB}=0.8V$                                     |     | 92  |     | %           |
| Minimum On-Time                  |   |     | 60  |     | nS          |
| Soft-start Time                  | $T_{ss}$  |     | 1   |     | mS          |
| Thermal Shutdown                 |   |     | 180 |     | $^{\circ}C$ |

## TYPICAL PERFORMANCE CHARACTERISTICS

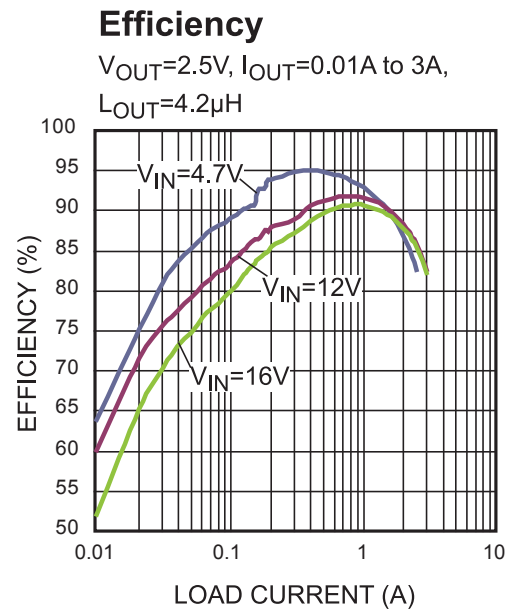
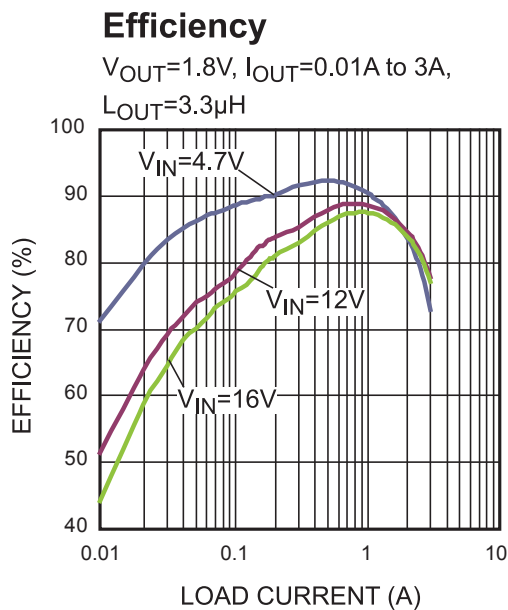
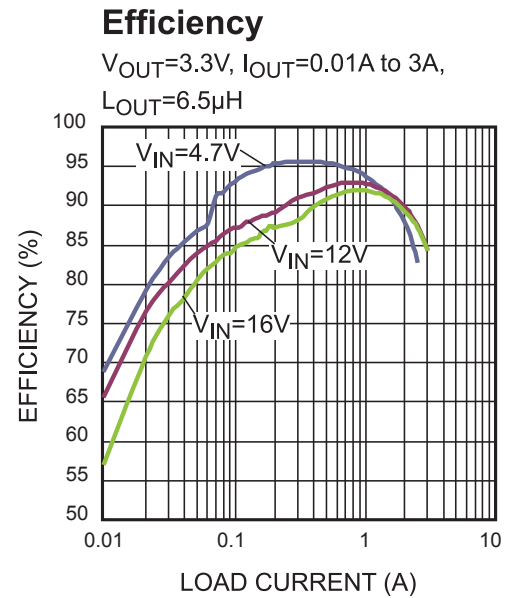
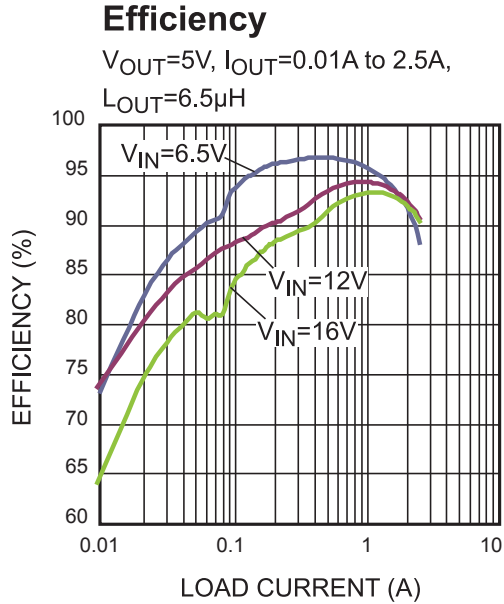

## OPERATION

### Internal Regulator

The SP1471 is a current mode step down DC/DC converter that provides excellent transient response with no extra external compensation components. This device contains an internal, low resistance, high voltage power MOSFET, and operates at a high 500K operating frequency to ensure a compact, high efficiency design with excellent AC and DC performance.

### Error Amplifier

The error amplifier compares the FB pin voltage with the internal FB reference (VFB) and outputs a current proportional to the difference between the two. This output current is then used to charge or discharge the internal compensation network to form the COMP voltage, which is used to control the power MOSFET current. The optimized internal compensation network minimizes the external component counts and simplifies the control loop design.

### Internal Soft-Start

The soft-start is implemented to prevent the converter output voltage from overshooting during startup. When the chip starts, the internal circuitry generates a soft-start voltage (SS) ramping up from 0V to 0.8V. When it is lower than the internal reference (REF), SS overrides REF so the error amplifier uses SS as the reference. When SS is higher than REF, REF regains control. The SS time is internally fixed to 1ms.

### Over-Current-Protection and Hiccup

The SP1471 has cycle-by-cycle over current limit when the inductor current peak value exceeds the set current limit threshold. Meanwhile, output voltage starts to drop until FB is below the Under-Voltage (UV) threshold, typically 30% below the reference. Once a UV is triggered, the SP1471 enters hiccup mode to periodically restart the part. This protection mode is especially useful when the output is dead-short to ground. The average short circuit current is greatly reduced to alleviate the thermal issue and to protect the regulator. The SP1471 exits the hiccup mode once the over current condition is removed.

### Startup and Shutdown

If both VIN and EN are higher than their appropriate thresholds, the chip starts. The reference block starts first, generating stable reference voltage and currents, and then the internal regulator is enabled. The regulator provides stable supply for the remaining circuitries. Three events can shut down the chip: EN low, VIN low and thermal shutdown. In the shutdown procedure, the signaling path is first blocked to avoid any fault triggering. The COMP voltage and the internal supply rail are then pulled down. The floating driver is not subject to this shutdown command.

## PACKAGE OUTLINE

### SOT23-6 PACKAGE OUTLINE AND DIMENSIONS

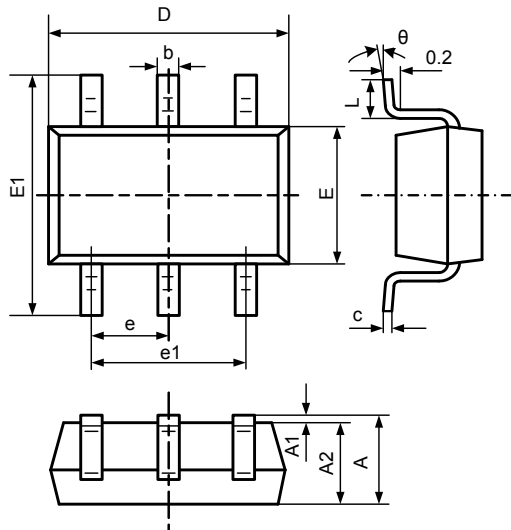

| SYMBOL | DIMENSION IN MILLIMETERS |       | DIMENSION IN INCHES |       |
|--------|--------------------------|-------|---------------------|-------|
|        | MIN                      |       | MIN                 | MAX   |
| A      | -                        | 1.450 | -                   | 0.057 |
| A1     | 0.000                    | 0.150 | 0.000               | 0.006 |
| A2     | 0.900                    | 1.300 | 0.035               | 0.051 |
| b      | 0.300                    | 0.500 | 0.012               | 0.020 |
| c      | 0.080                    | 0.220 | 0.003               | 0.009 |
| D      | 2.900 BSC                |       | 0.114 BSC           |       |
| E      | 1.600 BSC                |       | 0.063 BSC           |       |
| E1     | 2.800 BSC                |       | 0.110 BSC           |       |
| e      | 0.950 BSC                |       | 0.037 BSC           |       |
| e1     | 1.900 BSC                |       | 0.075 BSC           |       |
| L      | 0.300                    | 0.600 | 0.012               | 0.024 |
| theta  | 0°                       |       |                     | 8°    |

## X-ON Electronics

Largest Supplier of Electrical and Electronic Components

*Click to view similar products for [Switching Controllers](#) category:*

*Click to view products by [SPS manufacturer](#):*

Other Similar products are found below :

[AP3844CMTR-E1](#) [NCP1218AD65R2G](#) [NCP1234AD100R2G](#) [NCP1244BD065R2G](#) [NCP1336ADR2G](#) [NCP6153MNTWG](#)  
[NCP81005MNTWG](#) [NCP81101BMNTXG](#) [NCP81205MNTXG](#) [SJ6522AG](#) [SJE6600](#) [AZ7500BMTR-E1](#) [IR35215MTRPBF](#) [SG3845DM](#)  
[NCP4202MNR2G](#) [NCP4204MNTXG](#) [NCP6132AMNR2G](#) [NCP81102MNTXG](#) [NCP81141MNTXG](#) [NCP81203MNTXG](#) [NCP81206MNTXG](#)  
[NX2155HCUPTR](#) [UBA2051C](#) [IR35201MTRPBF](#) [FSL4110LRLX](#) [NCP1015ST65T3G](#) [NCP1240AD065R2G](#) [NCP1240FD065R2G](#)  
[NCP1336BDR2G](#) [NCP1361BABAYSNT1G](#) [NCP1230P100G](#) [NX2124CSTR](#) [SG2845M](#) [NCP1366BABAYDR2G](#) [NCP81101MNTXG](#)  
[TEA19362T/1J](#) [NCP81174NMNTXG](#) [NCP4308DMTTWG](#) [NCP4308DMNTWG](#) [NCP4308AMTTWG](#) [NCP1366AABAYDR2G](#)  
[NCP1256ASN65T1G](#) [NCP1251FSN65T1G](#) [NCP1246BLD065R2G](#) [MB39A136PFT-G-BND-ERE1](#) [NCP1256BSN100T1G](#) [LV5768V-A-](#)  
[TLM-E](#) [NCP1365AABCYDR2G](#) [IR35204MTRPBF](#) [MCP1633T-E/MG](#)