

MDCL0500C0-0016R0SHC DATASHEET



MODEL	MDCL0500C0-0016R0SHC
--------------	-----------------------------

Version	Revision of historical records
V2019-1 Trial Version	First Edition
V2020-1	Version Update

FEATURES

- Compact, fully enclosed splash proof design
- Highest power performance
- Individually balanced cells
- Over 1000,000 duty cycles
- Ultra-low internal resistance

APPLICATIONS

- Automotive
- Industrial
- Telecommunications
- Railway transportation
- Uninterruptible Power Supplies(UPS)

SPECIFICATIONS

Electrical	Characteristics
Nominal Capacitance	500 F
Capacitance Tolerance	0% / +20%
Rated Voltage	16 V
Surge Voltage	17 V
ESR,DC	1.8 mΩ
Maximum Continuous Current ($\Delta T=15^{\circ}\text{C}$)	100 A
Maximum Continuous Current ($\Delta T=40^{\circ}\text{C}$)	160 A
Maximum Peak Current,1sec.	2000 A
Leakage Current(25°C , after 72 h)	5.2 mA
Equalizing current	100 mA
Cell	CDCL3000C0-0002R7WLH
Number of Cells	6
Environment	
Operating Temperature Range	$-40^{\circ}\text{C} \sim +65^{\circ}\text{C}$
Storage Temperature Range	$-40^{\circ}\text{C} \sim +70^{\circ}\text{C}$
Environment Humidity	$\leq 90\%RH$
Physical	
Weight	5.7 kg
Power Terminals	M8/M10
Recommended Torque-Terminal	20/30 N·m
Vibration Specification	GB/T 11287-2000
Shock Specification	GB/T 14537-1993
Environment Protection	IP54
Monitoring	
Cell Voltage Monitoring	Overvoltage Alarm
Temperature	NTC Thermistor

SPECIFICATIONS

Power And Energy

Usable Power Density (Pd)	2994 W/kg
Impedance Match Power Density(Pmax)	6237 W/kg
Gravimetric Energy Density(Emax)	3.1 Wh/kg
Stored Energy	17.8 Wh

Life

High Temperature Life (at Rated Voltage & Maximum Operating Temperature)	1500 hours
Capacitance Change (%decrease from initial measured value) ESR Change (%increase from specified value)	≤20% ≤100%
Room Temperature Life (at Rated Voltage at 25°C)	10 years
Capacitance Change (%decrease from initial measured value) ESR Change (%increase from specified value)	≤20% ≤100%
Cycle Life (Number of cycles)	1,000,000
Capacitance Change (%decrease from initial measured value) ESR Change (%increase from specified value)	≤20% ≤100%
Shelf Life (25°C, uncharged)	4 years

Safe

Factory High-Pot Test	2500 VDC
-----------------------	----------

NOTES

1. Surge voltage is non-repetitive. The duration must not exceed 1second.
2. Maximum peak current in non-repetitive. The duration must not exceed 1second.
3. Formula of maximum peak current:

$$I_{peak} = \frac{1 / 2CV}{C \times ESR_{DC} + 1}$$

C is rated capacity, V is rated voltage.

4. Formula of power and energy:

Usable Power Density :

$$P_d = \frac{0.12V^2}{ESR_{DC} \times mass}$$

Gravimetric Energy Density:

$$E_{max} = \frac{1 / 2CV^2}{3600 \times mass}$$

Impedance Match Power Density:

$$P_{max} = \frac{V^2}{4ESR_{DC} \times mass}$$

Stored Energy:

$$E = \frac{1 / 2CV^2}{3600}$$

MEASURING METHOD

- 1) Charge and Discharge procedure (Figure 1)
 - a) Charge the capacitor using constant current I to rated voltage V_0 ;
 - b) Keep rated voltage 5 min;
 - c) Discharge the capacitor using constant current I to half rated voltage, record discharge time T_1 during voltage change from V_1 to V_2 ;
 - d) Rest 2-5s, record voltage change ΔV ;
 - e) Discharge it to a very low voltage around 0.01V;
 - f) $V_1=80\% V_0$, $V_2=50\% V_0$.

2) Capacitance

$$C = I * T_1 / (V_1 - V_2)$$

C: Capacitance(F);

I : Constant Discharge Current(A);

T_1 : Discharge Time(s);

V_1 - V_2 : Voltage Change (V).

3) DC ESR

$$DC\ ESR = \Delta V / I$$

DC ESR: DC Equivalent Series Resistance(Ω)

ΔV : Voltage Change(V);

I: Constant Discharge Current (A);

4) AC ESR

Measure AC ESR using LCR meter

Frequency: 1KHz;

Voltage: fully discharge

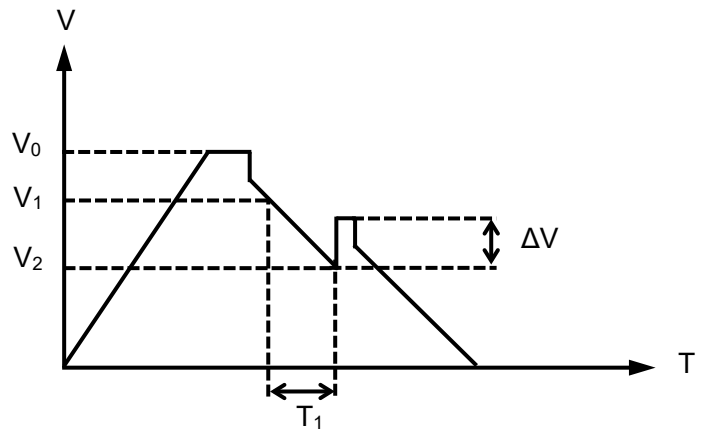
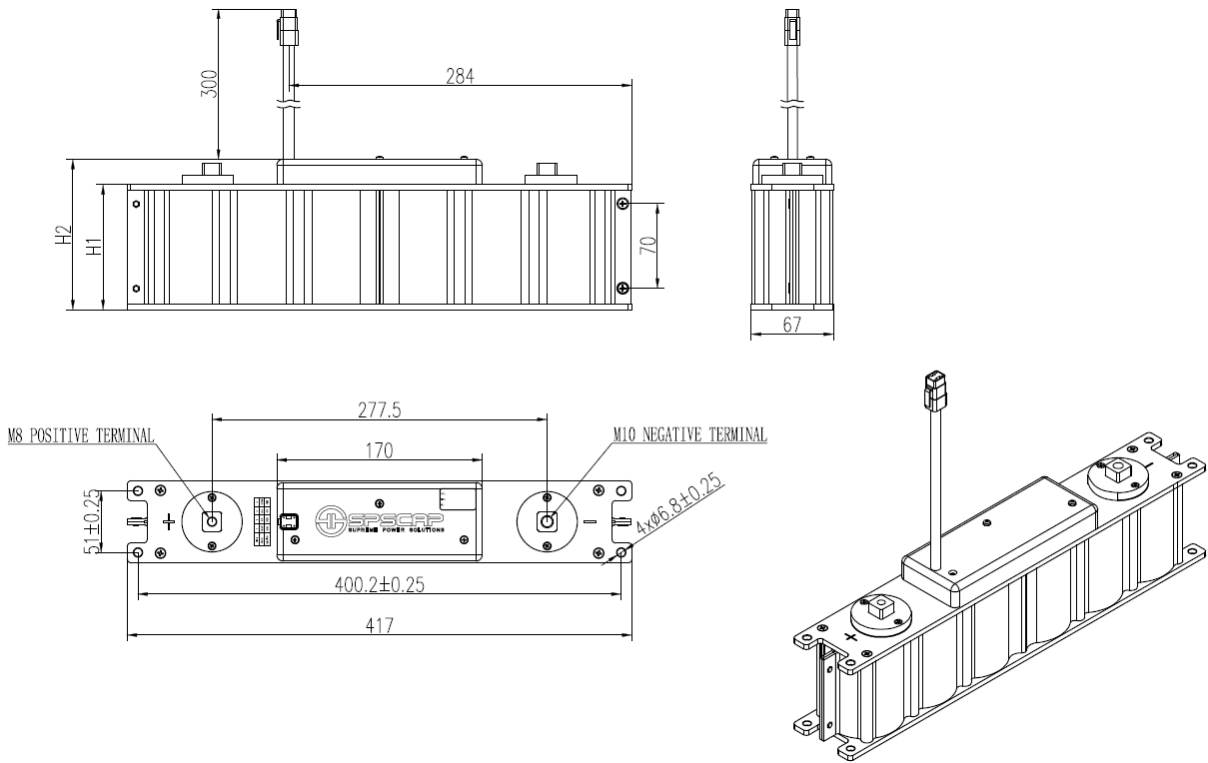

Figure 1

Pin Number	Wire Color	Definition	Output
1	Black	GND	
2	Red	Overvoltage Alarm	High - Inactive
			Low - Active
3	Void	Void	
4	Green	Temperature	

DIMENSIONS



MODEL	Maximum Overall Dimension			
	L(±1mm)	W(±0.5mm)	H1(max/mm)	H2(max/mm)
MDCL0500C0-0016R0SHC	417	67	157	179

All rights reserved. Design and specifications are subjected to change without notice.

NINGBO CRRC NEW ENERGY TECHNOLOGY CO.,LTD.

Add: No.199 Shidai Road,Wuxiang Town,Yinzhou District,
Ningbo,Zhejiang,China

Email: info@spscap.com

Website: www.spscap.com



X-ON Electronics

Largest Supplier of Electrical and Electronic Components

Click to view similar products for [Supercapacitors](#) / [Ultracapacitors](#) category:

Click to view products by [SPSCAP](#) manufacturer:

Other Similar products are found below :

[C-TEC1225 P](#) [SCCY73B407SLBLE](#) [CDCL3000C0-002R85STB](#) [CDCM0800C0-0002R7SPD](#) [MDCM0058C0-0016R0TBZ](#) [FE0H473ZF](#)
[MAL223551012E3](#) [MAL223551014E3](#) [MAL223551015E3](#) [MAL223551016E3](#) [MAL223551007E3](#) [MAL223551001E3](#) [MAL223551008E3](#)
[MAL219612474E3](#) [CPM3225A-2K](#) [HS208F](#) [DMF3Z5R5H474M3DTA0](#) [DRE10/2.5](#) [DRL106S0TI25RRDAP](#) [DRL226S0TK25RR](#)
[106DCN2R7M](#) [SCCT30B156SRB](#) [SCMR14C474MSBA0](#) [SCMR22C155MSBA0](#) [DRL475S0TG20RRDAP](#) [GW209F](#) [TV1020-3R0605-R](#)
[TV1245-3R0346-R](#) [SCCX50B207VSB](#) [PAS0815LS2R5105](#) [HVZ0E475NF](#) [SCMR18F105PSBA0](#) [FT0H565ZF](#) [FE0H224ZF](#)
[SCCT30E156SRB](#) [MAL222090006E3](#) [SCCY68B407SSBLE](#) [CPH3225A-2K](#) [207DCN2R7M](#) [DB5U307W35050HA](#) [SCCX50B227SSBLE](#)
[DGH505Q5R5](#) [DGH305Q2R7](#) [DGH505Q2R7](#) [DGH705Q2R7](#) [DGH506Q2R7](#) [DGH504Q5R5](#) [DGH335Q2R7](#) [DGH256Q2R7](#) [DGH255Q5R5](#)