

**DESCRIPTION**

- Collector-Emitter Sustaining Voltage-  
:  $V_{CEO(SUS)} = 60V(\text{Min})$
- High DC Current Gain-  
:  $h_{FE} = 100(\text{Min})@ (V_{CE} = 2V, I_C = 1.5A)$
- Low Saturation Voltage-  
:  $V_{CE(sat)} = 0.3V(\text{Max})@ (I_C = 4A, I_B = 0.2A)$

**APPLICATIONS**

- Designed for use as a driver in DC/DC converters and actuators.

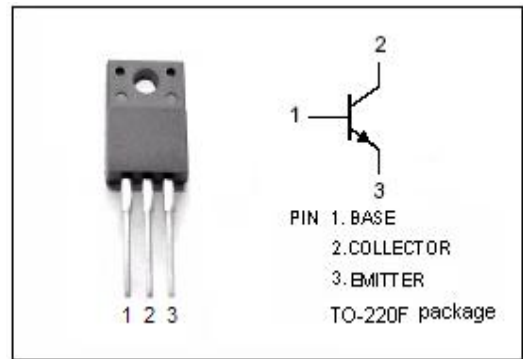

**ABSOLUTE MAXIMUM RATINGS( $T_a=25^\circ\text{C}$ )**

SYMBOL	PARAMETER	VALUE	UNIT
$V_{CBO}$	Collector-Base Voltage	100	V
$V_{CEO}$	Collector-Emitter Voltage	60	V
$V_{EBO}$	Emitter-Base Voltage	7.0	V
$I_C$	Collector Current-Continuous	7.0	A
$I_{CM}$	Collector Current-Pulse	14	A
$I_B$	Base Current-Continuous	3.5	A
$P_T$	Total Power Dissipation @ $T_C=25^\circ\text{C}$	30	W
	Total Power Dissipation @ $T_a=25^\circ\text{C}$	2.0	
$T_J$	Junction Temperature	150	$^\circ\text{C}$
$T_{stg}$	Storage Temperature	-55~150	$^\circ\text{C}$

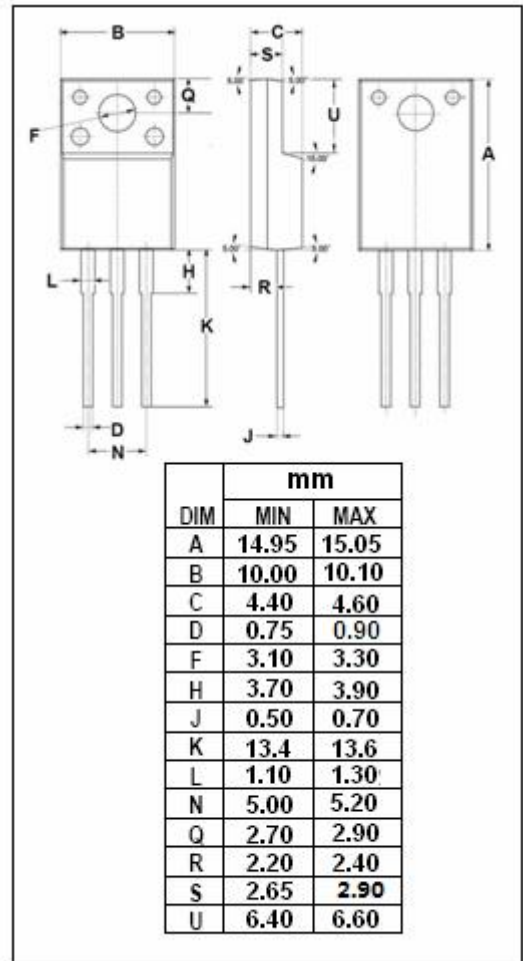

**ELECTRICAL CHARACTERISTICS**

T<sub>j</sub>=25°C unless otherwise specified

SYMBOL	PARAMETER	CONDITIONS	MIN	TYP.	MAX	UNIT
V <sub>CEO(SUS)</sub>	Collector-Emitter Sustaining Voltage	I <sub>C</sub> =50mA, I <sub>B</sub> =0	60			V
V <sub>CE(sat)-1</sub>	Collector-Emitter Saturation Voltage	I <sub>C</sub> = 4A; I <sub>B</sub> = 0.2A			0.3	V
V <sub>CE(sat)-2</sub>	Collector-Emitter Saturation Voltage	I <sub>C</sub> = 6A; I <sub>B</sub> = 0.3A			0.5	V
V <sub>BE(sat)-1</sub>	Base-Emitter Saturation Voltage	I <sub>C</sub> = 4A; I <sub>B</sub> = 0.2A			1.2	V
V <sub>BE(sat)-2</sub>	Base-Emitter Saturation Voltage	I <sub>C</sub> = 6A; I <sub>B</sub> = 0.3A			1.5	V
I <sub>CBO</sub>	Collector Cutoff Current	V <sub>CB</sub> = 60V ; I <sub>E</sub> = 0			10	μ A
I <sub>CER</sub>	Collector Cutoff Current	V <sub>CE</sub> = 60V ; R <sub>BE</sub> = 50 Ω , T <sub>a</sub> =125°C			1.0	mA
I <sub>EBO</sub>	Emitter Cutoff Current	V <sub>EB</sub> = 5V; I <sub>C</sub> = 0			10	μ A
h <sub>FE-1</sub>	DC Current Gain	I <sub>C</sub> = 0.7A ; V <sub>CE</sub> = 2V	100			
h <sub>FE-2</sub>	DC Current Gain	I <sub>C</sub> = 1.5A ; V <sub>CE</sub> = 2V	100		400	
h <sub>FE-3</sub>	DC Current Gain	I <sub>C</sub> = 4.0A ; V <sub>CE</sub> = 2V	60			
C <sub>OB</sub>	Output Capacitance	I <sub>E</sub> = 0 ; V <sub>CB</sub> = 10V; f= 1.0MHz		100		pF
f <sub>T</sub>	Current-Gain—Bandwidth Product	I <sub>C</sub> = 1A ; V <sub>CE</sub> = 10V	30			MHz

Switching times

t <sub>on</sub>	Turn-on Time	I <sub>C</sub> = 4.0A , R <sub>L</sub> = 12.5 Ω , I <sub>B1</sub> = -I <sub>B2</sub> = 0.2A, V <sub>CC</sub> ≈ 50V			0.3	μ s
t <sub>stg</sub>	Storage Time				1.5	μ s
t <sub>f</sub>	Fall Time				0.3	μ s

◆ **h<sub>FE-2</sub> Classifications**

M	L	K
100-200	150-300	200-400

## X-ON Electronics

Largest Supplier of Electrical and Electronic Components

*Click to view similar products for [Bipolar Transistors - BJT category](#):*

*Click to view products by [SPTECH manufacturer](#):*

Other Similar products are found below :

[619691C](#) [MCH4017-TL-H](#) [MJ15024/WS](#) [MJ15025/WS](#) [BC546/116](#) [BC556/FSC](#) [BC557/116](#) [BSW67A](#) [HN7G01FU-A\(T5L,F,T](#)  
[NJVMJD148T4G](#) [NSVMMBT6520LT1G](#) [NTE187A](#) [NTE195A](#) [NTE2302](#) [NTE2330](#) [NTE2353](#) [NTE316](#) [IMX9T110](#) [NTE63](#) [NTE65](#)  
[C4460](#) [SBC846BLT3G](#) [2SA1419T-TD-H](#) [2SA1721-O\(TE85L,F\)](#) [2SA1727TLP](#) [2SA2126-E](#) [2SB1202T-TL-E](#) [2SB1204S-TL-E](#) [2SC5488A-](#)  
[TL-H](#) [2SD2150T100R](#) [SP000011176](#) [FMC5AT148](#) [2N2369ADCSM](#) [2SB1202S-TL-E](#) [2SC2412KT146S](#) [2SC4618TLN](#) [2SC5490A-TL-H](#)  
[2SD1816S-TL-E](#) [2SD1816T-TL-E](#) [CMXT2207 TR](#) [CPH6501-TL-E](#) [MCH4021-TL-E](#) [BC557B](#) [TTC012\(Q\)](#) [BULD128DT4](#) [JANTX2N3810](#)  
[Jantx2N5416](#) [US6T6TR](#) [KSF350](#) [068071B](#)