

## SPTECH Product Specification

# SPTECH Silicon PNP Power Transistor

# NJW1302G

### DESCRIPTION

- With TO-3PN packaging
- Reliable performance at higher powers
- Accurate reproduction of Input signal
- Greater dynamic range
- Minimum Lot-to-Lot variations for robust device performance and reliable operation

### APPLICATIONS

- Switching regulators
- High frequency inverters
- General purpose power amplifiers

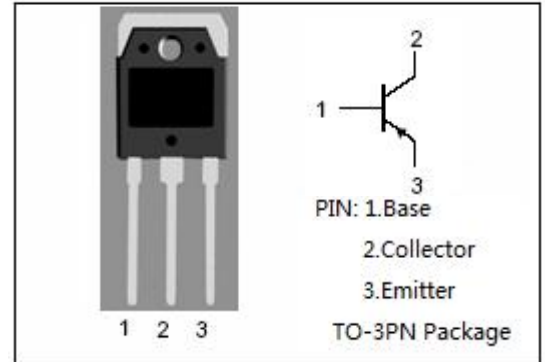

### ABSOLUTE MAXIMUM RATINGS( $T_a=25^{\circ}\text{C}$ )

SYMBOL	PARAMETER	VALUE	UNIT
$V_{CBO}$	Collector-Base Voltage	-250	V
$V_{CEO}$	Collector-Emitter Voltage	-250	V
$V_{CEX}$	Collector-Emitter Voltage $V_{EB}=5\text{V}$	-250	V
$V_{EBO}$	Emitter-Base Voltage	-5	V
$I_C$	Collector Current-Continuous	-15	A
$I_{CM}$	Collector Current-Peak	-30	A
$I_B$	Base Current-Continuous	-1.6	A
$P_T$	Total Power Dissipation @ $T_C=25^{\circ}\text{C}$	200	W
$T_J$	Junction Temperature	150	$^{\circ}\text{C}$
$T_{stg}$	Storage Temperature Range	-65~150	$^{\circ}\text{C}$

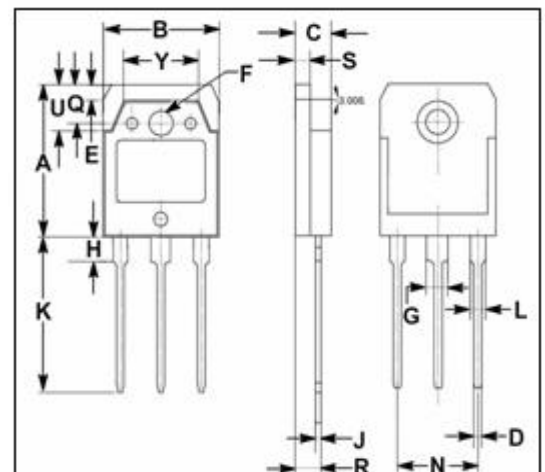

DIM	mm	
	MIN	MAX
A	19.60	20.30
B	15.50	15.70
C	4.70	4.90
D	0.90	1.10
E	1.90	2.10
F	3.40	3.60
G	2.90	3.20
H	3.20	3.40
J	0.595	0.605
K	19.80	20.70
L	1.90	2.20
N	10.89	10.91
Q	4.90	5.10
R	3.35	3.45
S	1.995	2.100
U	5.90	6.20
Y	9.90	10.10

### THERMAL CHARACTERISTICS

SYMBOL	PARAMETER	MAX	UNIT
$R_{th\ j-c}$	Thermal Resistance, Junction to Case	0.63	$^{\circ}\text{C/W}$

## SPTECH Product Specification

# SPTECH Silicon PNP Power Transistor

# NJW1302G

### ELECTRICAL CHARACTERISTICS

$T_C=25^\circ\text{C}$  unless otherwise specified

SYMBOL	PARAMETER	CONDITIONS	MIN	TYP.	MAX	UNIT
$V_{CEO(SUS)}$	Collector-Emitter Sustaining Voltage	$I_C=-100\text{mA}; I_B=0$	-250			V
$V_{CE(sat)}$	Collector-Emitter Saturation Voltage	$I_C=-8\text{A}; I_B=-0.8\text{A}$			-0.6	V
$V_{BE(on)}$	Base-Emitter On Voltage	$I_C=-8\text{A}; V_{CE}=-5\text{V}$			-1.5	V
$I_{CBO}$	Collector Cutoff Current	$V_{CB}=-250\text{V}$			-50	mA
$I_{CEO}$	Collector Cutoff Current	$V_{CE}=-250\text{V}$			-50	mA
$I_{EBO}$	Emitter Cutoff Current	$V_{EB}=-5\text{V}$			-5	mA
$h_{FE-1}$	DC Current Gain	$I_C=-0.1\text{A}; V_{CE}=-5\text{V}$	75		150	
$h_{FE-2}$	DC Current Gain	$I_C=-1\text{A}; V_{CE}=-5\text{V}$	75		150	
$h_{FE-3}$	DC Current Gain	$I_C=-3\text{A}; V_{CE}=-5\text{V}$	75		150	
$h_{FE-4}$	DC Current Gain	$I_C=-5\text{A}; V_{CE}=-5\text{V}$	60			
$h_{FE-5}$	DC Current Gain	$I_C=-8\text{A}; V_{CE}=-5\text{V}$	45			

## X-ON Electronics

Largest Supplier of Electrical and Electronic Components

*Click to view similar products for [Bipolar Transistors - BJT category](#):*

*Click to view products by [SPTECH manufacturer](#):*

Other Similar products are found below :

[619691C](#) [MCH4017-TL-H](#) [MJ15024/WS](#) [MJ15025/WS](#) [BC546/116](#) [BC556/FSC](#) [BC557/116](#) [BSW67A](#) [HN7G01FU-A\(T5L,F,T](#)  
[NJVMJD148T4G](#) [NSVMMBT6520LT1G](#) [NTE187A](#) [NTE195A](#) [NTE2302](#) [NTE2330](#) [NTE2353](#) [NTE316](#) [IMX9T110](#) [NTE63](#) [NTE65](#)  
[C4460](#) [SBC846BLT3G](#) [2SA1419T-TD-H](#) [2SA1721-O\(TE85L,F\)](#) [2SA1727TLP](#) [2SA2126-E](#) [2SB1202T-TL-E](#) [2SB1204S-TL-E](#) [2SC5488A-](#)  
[TL-H](#) [2SD2150T100R](#) [SP000011176](#) [FMC5AT148](#) [2N2369ADCSM](#) [2SB1202S-TL-E](#) [2SC2412KT146S](#) [2SC4618TLN](#) [2SC5490A-TL-H](#)  
[2SD1816S-TL-E](#) [2SD1816T-TL-E](#) [CMXT2207 TR](#) [CPH6501-TL-E](#) [MCH4021-TL-E](#) [BC557B](#) [TTC012\(Q\)](#) [BULD128DT4](#) [JANTX2N3810](#)  
[Jantx2N5416](#) [US6T6TR](#) [KSF350](#) [068071B](#)