

# OXY-LC

## Oxygen Sensor Interface



### FEATURES AND BENEFITS

- Provides the electronics necessary to power and control SST's range of dynamic oxygen ( $O_2$ ) sensors.
- Built in pressure sensor for barometric pressure compensation.
- Three interface variants available: RS485, 0-10V<sub>DC</sub> and 4-20mA outputs.
- RS485 output benefits:
  1. RS485 Modbus RTU Protocol allows complete control of the sensor operation and access to all available information including sensor diagnostics, barometric pressure and pressure sensor temperature.
  2. Adjustable communication settings including the ability to change the slave address of the interface allowing up to 32 devices to communicate on the same bus. Each device presents a 'single unit load' to the network. Ideal when multiple oxygen readings are required.
  3. Three modes of operation; OFF, ON and Standby. Standby applies half the sensor heater voltage to protect the sensor from condensation and reduce the warm up time when returning to ON mode.
  4. Adjustable sensor heater voltages to suit different sensor types.
  5. Default calibration to 20.7%  $O_2$  for calibration in normal air but can be changed to any other  $O_2$  concentration for calibration with reference gases.
- 0-10V<sub>DC</sub> and 4-20mA output benefits:
  1. High accuracy linear output represents either 0.1 to 25%  $O_2$  or 0.1 to 100%  $O_2$ .
  2. Four sensor heater voltages available to suit different sensor types and cable lengths
  3. PWM output for diagnostics also doubles up as a calibration input.
  4. For the 0.1 to 25%  $O_2$  variants the default calibration is to 20.7%  $O_2$  for calibration in normal air. For the 0.1 to 100%  $O_2$  variants the default calibration is to 100%  $O_2$  for calibration to full scale with pure oxygen.
- Adaptive software filtering provides a fast sensor response coupled with a stable oxygen output.
- Interface mounted screw terminals for easy wiring with reverse voltage and transient overvoltage

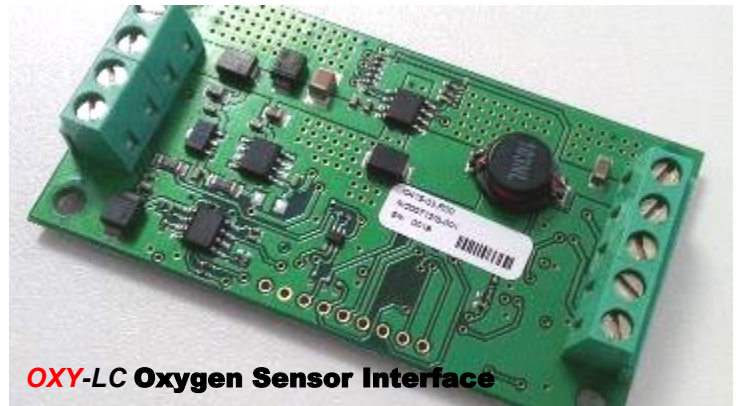

### APPLICATIONS

- Combustion control including oil, gas and biomass boiler applications.
- Oxygen generation systems.
- Medical.
- Scientific including respiratory studies of a community or an organism, plants and animals.
- Food and beverage packaging
- Applications where low oxygen is key including fermentation, rust and corrosion prevention, fire prevention, inerting and purging.<sup>(1)</sup>

### Notes:

1. Minimum allowable  $O_2$  concentration is 0.1%  $O_2$ . Operation below 0.1%  $O_2$  will damage the sensing element and must be avoided.

## CONTENTS

|                             |                        |
|-----------------------------|------------------------|
| General Description         | <a href="#">Page 3</a> |
| Specifications              | <a href="#">Page 3</a> |
| Performance Characteristics | <a href="#">Page 3</a> |

### **RS485 Variant**

|                                |                               |
|--------------------------------|-------------------------------|
| Electrical Connections         | <a href="#">Page 4</a>        |
| Default Communication Settings | <a href="#">Page 4</a>        |
| Modbus Input Registers         | <a href="#">Pages 5 and 6</a> |
| Modbus Holding Registers       | <a href="#">Page 7</a>        |
| Modbus Notes                   | <a href="#">Pages 8 to 10</a> |

### **Analogue Variants (0-10Vdc and 4-20mA)**

|                              |                                |
|------------------------------|--------------------------------|
| Electrical Connections       | <a href="#">Page 11</a>        |
| Analogue Output Values Table | <a href="#">Page 11</a>        |
| Calibrate IN/PWM OUT Notes   | <a href="#">Pages 12 to 14</a> |

### **General Operating Procedures**

|                                      |                         |
|--------------------------------------|-------------------------|
| General Operating Overview           | <a href="#">Page 15</a> |
| Installation Procedure               | <a href="#">Page 16</a> |
| Calibration Procedure                | <a href="#">Page 17</a> |
| Normal Operation Diagnostics Routine | <a href="#">Page 18</a> |
| Shutdown Procedure                   | <a href="#">Page 19</a> |

|  |                                 |
|--|---------------------------------|
| Sensor Operating Tips                    | <a href="#">Pages 20 and 21</a> |
| Outline Drawing and Mounting Information | <a href="#">Page 22</a>         |
| Ordering Information                     | <a href="#">Page 23</a>         |

## GENERAL DESCRIPTION

The OXY-LC Oxygen Sensor Interface provides all necessary electronics to power and control SST Sensing's range of dynamic oxygen sensors.

Calibration, or re-referencing, is required when a sensor is attached to the interface for the first time. Regular calibration removes any sensor drift that may occur during the first few hundred hours after a new sensor is connected. For maximum accuracy in the range 0.1 to 25% O<sub>2</sub> it is recommended that a calibration to 20.7% O<sub>2</sub> should occur every time the sensor is known to be in fresh air (20.7% O<sub>2</sub> takes into account typical humidity levels). A software delay prevents calibration from being completed before the sensor has been in ON mode for 5 minutes. If a calibration is initialised during this delay the unit will calibrate after the 5 minutes have elapsed.

### For detailed descriptions on all functions including calibration;

Section A (Pages 4 to 10) describes the RS485 variant.

Section B (Pages 11 to 14) describes the analogue output variants.

Section C (Pages 15 to 19) describes the general operating procedures as flow charts.

Oxygen Sensor Operating Principle Application Note: AN0043 available at [www.sstsensing.com](http://www.sstsensing.com).

## SPECIFICATIONS

### Electrical

|                     |   |
|---------------------|---|
| Supply Voltage      | 8-28V <sub>DC</sub> (RS485 Variant)<br>20-28V <sub>DC</sub> (0-10V <sub>DC</sub> and 4-20mA variants) |
| Current consumption | Varies with Supply Voltage, typical 600mA max @ 24V <sub>DC</sub> , 1.2A max @ 12V <sub>DC</sub>      |

### Temperature limits

|           |             |
|-----------|-------------|
| Operating | -30 to 70°C |
| Storage   | -40 to 85°C |

### Operating pressure limits (Sensor and interface for correct barometric pressure compensation)

|          |                          |
|----------|--------------------------|
| Pressure | 260 to 1260mbar absolute |
|----------|--------------------------|

## PERFORMANCE CHARACTERISTICS

| Characteristic  | Min.                                     | Typ.     | Max.      | Unit             |
|---|--|----------|-----------|------------------|
| Output inactive start up delay (heater warm up):<br>From OFF to ON Mode<br>From Standby to ON Mode (RS485 variant only) |  | 60<br>20 |           | s                |
| Initial warm up time (till stable output)   | 5  | 10       |           | min              |
| Measurement Ranges :<br>0-10V <sub>DC</sub> and 4-20mA only<br>All Variants   | 0.1 <sup>(1)</sup><br>0.1 <sup>(1)</sup> |          | 25<br>100 | % O <sub>2</sub> |
| Accuracy After Calibration <sup>(2)</sup>   |  |          | 0.5       | % O <sub>2</sub> |
| Repeatability After Calibration   |  |          | 0.5       | % O <sub>2</sub> |
| Output Resolution   |  |          | 0.01      | % O <sub>2</sub> |
| Response Time (10-90%):<br>Fast Response Sensor connected<br>Standard Response Sensor connected                         |  |          | 4<br>15   | s                |

### Notes:

1. Minimum allowable O<sub>2</sub> concentration is 0.1% O<sub>2</sub>. Operation below 0.1% O<sub>2</sub> will damage the sensing element and must be avoided.
2. For the analogue output variants accuracy stated is valid when calibrated at the default calibration value. For the RS485 variant accuracy stated is valid when calibrated at the default 20.7% O<sub>2</sub> over the range 0.1 to 25% O<sub>2</sub>. For maximum accuracy above 25% O<sub>2</sub> the interface and sensor should be calibrated to full scale of the required range using certified gas.

**ELECTRICAL CONNECTIONS**

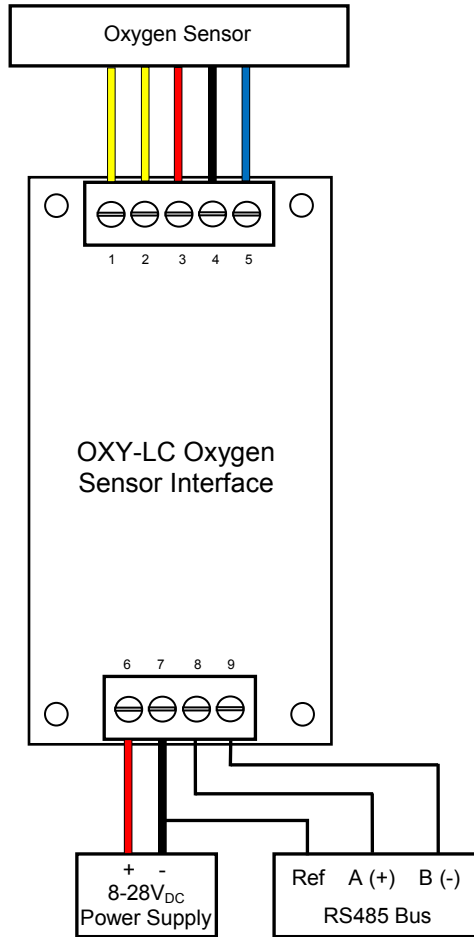

| PIN | RS485 Variant  |
|-----|--|
| 1   | Sensor Heater + (Yellow, Grey or H)                        |
| 2   | Sensor Heater 0V <sub>DC</sub> (Yellow, Yellow/Green or H) |
| 3   | Sensor Pump (Red, Brown or P)                              |
| 4   | Sensor Common (Black or C)                                 |
| 5   | Sensor Sense (Blue or S)                                   |
| 6   | 8-28V <sub>DC</sub>  |
| 7   | 0V <sub>DC</sub>   |
| 8   | RS485 A (+)  |
| 9   | RS485 B (-)  |

| RS485 Communication Settings | Default Value |
|------------------------------|---------------|
| Address                      | 1             |
| Baudrate                     | 9600          |
| Parity                       | None          |
| Stopbits                     | 1             |

Notes:

- RS485 A and B (pins 8 and 9) are a half-duplex system and are referenced to the power supply 0V<sub>DC</sub> (pin 7). A connection should be made between pin 7 and the reference or common connection of the RS485 Bus.
- Care should be taken when connecting the RS485 A and B connections to your system. The TIA-485 signalling specification states that signal **A** is the **inverting** or '-' pin and signal **B** is the **non-inverting** or '+' pin. This is in conflict with the A and B naming used by a number of differential transceiver manufacturers, including the transceiver used in the OXY-LC Oxygen Sensor Interface. Therefore always ensure the '+' of the OXY-LC Oxygen Sensor Interface is connected to the '+' input of the RS485 Bus and the '-' of the OXY-LC Oxygen Sensor Interface is connected to the '-' input of the RS485 Bus.
- The default communications settings can be amended to suit the application by connecting to the interface using the default settings then amending the Modbus registers associated with the communications as outlined in page 7 and Modbus note 6.
- Every SST oxygen sensor has two heater connections which should be connected to pins 1 & 2 of the OXY-LC Oxygen Sensor Interface, the heater coil has no polarity. However when connecting to a sensor where the sensor housing is one of the heater connections (O2S-FR-T4 Range) pin 2 of the OXY-LC Oxygen Sensor Interface should be connected to the housing

## MODBUS REGISTERS SPECIFICATIONS AND DESCRIPTIONS

### Input Registers

| Name                  | Register Address  | Description  | Action                                |
|-----------------------|-------------------|--|---------------------------------------|
| <b>O2% Average</b>    | 0x7531<br>(30001) | = x / 100 %<br>(Where: 0 = 0%, 2070 = 20.70%)<br>Output uses an adaptive filtering method to ensure maximum stability and response to oxygen changes                                       | Monitor in system                     |
| <b>O2% Raw</b>        | 0x7532<br>(30002) | = x / 100 %<br>(Where: 0 = 0%, 2070 = 20.70%)<br>Instantaneous oxygen reading  | No action                             |
| <b>Asymmetry</b>      | 0x7533<br>(30003) | = x / 1000<br>(Where: 1000 = 1.000, 1023 = 1.023)  | Monitor in system (See Modbus Note 1) |
| <b>System Status</b>  | 0x7534<br>(30004) | 0 = Idle<br>1 = Start up routine<br>2 = Operating<br>3 = Shut down routine<br>4 = Standby Mode   | Monitor in system                     |
| <b>Error/Warnings</b> | 0x7535<br>(30005) | Bit 0 (LSB) = Pump Error<br>Bit 1 = Heater Voltage Error<br>Bit 2 = Asymmetry Warning<br>Bit 3 = O2 Under 0.1% Warning<br>Bit 4 = Pressure Sensor Warning<br>Bit 5 = Pressure Sensor Error | Monitor in system (See Modbus Note 1) |
| <b>Heater Voltage</b> | 0x7536<br>(30006) | = x / 100 Volts (Where 443 = 4.43 Volts)   | Monitor in system (See Modbus Note 1) |
| <b>TD Average</b>     | 0x7537<br>(30007) | = x * 0.1ms (Where 2033 = 203.3ms)   | No action                             |
| <b>TD Raw</b>         | 0x7538<br>(30008) | = x * 0.1ms (Where 2033 = 203.3ms)   | No action                             |
| <b>TP</b>             | 0x7539<br>(30009) | = x * 0.1ms (Where 2033 = 203.3ms)   | No action                             |
| <b>T1</b>             | 0x753A<br>(30010) | = x * 0.1ms (Where 2033 = 203.3ms)   | No action                             |
| <b>T2</b>             | 0x753B<br>(30011) | = x * 0.1ms (Where 2033 = 203.3ms)   | No action                             |
| <b>T4</b>             | 0x753C<br>(30012) | = x * 0.1ms (Where 2033 = 203.3ms)   | No action                             |
| <b>T5</b>             | 0x753D<br>(30013) | = x * 0.1ms (Where 2033 = 203.3ms)   | No action                             |

## MODBUS REGISTERS SPECIFICATIONS AND DESCRIPTIONS

### Input Registers (continued)

| Name                               | Register Address  | Description  | Action                                |
|------------------------------------|-------------------|--|---------------------------------------|
| <b>PPO<sub>2</sub> Real</b>        | 0x753E<br>(30014) | = x * 0.1 PPO <sub>2</sub><br>(Where 2756 = 275.6 PPO <sub>2</sub> )             | Monitor in system                     |
| <b>PPO<sub>2</sub> Raw</b>         | 0x753F<br>(30015) | = x * 0.1 PPO <sub>2</sub><br>(Where 2756 = 275.6 PPO <sub>2</sub> )             | Monitor in system                     |
| <b>Pressure</b>                    | 0x7540<br>(30016) | mbar<br>(See Modbus Note 7)  | Monitor in system                     |
| <b>Pressure Sensor Temperature</b> | 0x7541<br>(30017) | °C (2's complement)<br>(See Modbus Note 7)                                       | Monitor in system                     |
| <b>Calibration Status</b>          | 0x7542<br>(30018) | 0 = Calibration Idle<br>1 = Calibration in Progress<br>2 = Calibration Completed | Monitor in system (See Modbus Note 4) |
| <b>Year of Manufacture</b>         | 0x7543<br>(30019) | =YYYY  | No action                             |
| <b>Day of Manufacture</b>          | 0x7544<br>(30020) | =DDD   | No action                             |
| <b>Serial Number</b>               | 0x7545<br>(30021) | =XXXXX   | No action                             |
| <b>Software Revision</b>           | 0x7546<br>(30022) | =RRR   | No action                             |

## MODBUS REGISTERS SPECIFICATIONS AND DESCRIPTIONS

### Holding Registers

| Name   | Register Address  | Allowed Values   | Default | Description   | Action   |
|--|-------------------|--|---------|---|--|
| <b>Sensor ON, OFF and Standby</b>            | 0x9C41<br>(40001) | 0 = Sensor OFF<br>1 = Sensor ON<br>2 = Standby   | -       | System Control  | Set in system (See Modbus Note 3)                    |
| <b>Clear Error Flags</b>                     | 0x9C42<br>(40002) | 0 = IDLE<br>1 = Clear Errors and Warnings  | -       | Clear all Error flags                                       | Set in system (See Modbus Note 1)                    |
| <b>Shutdown Delay</b>                        | 0x9C43<br>(40003) | 0 - 65535  | 0       | x seconds   | Set in system (See Modbus Notes 2 and 9)             |
| <b>Calibration Control</b>                   | 0x9C44<br>(40004) | 0 = Default Condition<br>1 = Activate Calibration<br>2 = Calibration Status Reset                    | 0       | Calibration Control.  | Set in system (See Modbus Note 4)                    |
| <b>Calibration (%)</b>                       | 0x9C45<br>(40005) | 0 - 65535  | 2070    | Calibration % Input<br>(Where 20.70% is input as 2070)      | Set in system (See Modbus Notes 4 and 9)             |
| <b>Address</b>                               | 0x9C46<br>(40006) | 1 - 247  | 1       | RS485 Setup Interface Slave Address                         | Set in system if required (See Modbus Note 5)        |
| <b>Baud</b>                                  | 0x9C47<br>(40007) | 0 = 2400<br>1 = 4800<br>2 = 9600<br>3 = 19200<br>4 = 38400<br>5 = 57600<br>6 = 115200                | 2       | RS485 Setup   | Set in system if required (See Modbus Note 6)        |
| <b>Parity</b>                                | 0x9C48<br>(40008) | 0 = None<br>1 = Odd<br>2 = Even  | 0       | RS485 Setup   | Set in system if required (See Modbus Note 6)        |
| <b>Stopbits</b>                              | 0x9C49<br>(40009) | 0 = 1<br>1 = 2   | 0       | RS485 Setup   | Set in system if required (See Modbus Note 6)        |
| <b>RS485 Setup Changes Apply and Save</b>    | 0x9C4A<br>(40010) | 0 = Idle<br>1 = Apply and Save   | 0       | Commits any changes to the RS485 Setup registers to memory. | Set in system if required (See Modbus Notes 6 and 9) |
| <b>Applied Heater Voltage</b>                | 0x9C4B<br>(40011) | 0 = 4V <sub>DC</sub><br>1 = 4.2V <sub>DC</sub><br>2 = 4.35V <sub>DC</sub><br>3 = 4.55V <sub>DC</sub> | -       | Heater setup  | Set in system if required (See Modbus Note 8)        |
| <b>Heater Voltage Changes Apply and Save</b> | 0x9C4C<br>(40012) | 0 = Idle<br>1 = Apply and Save   | 0       | Commits any changes to the heater setup registers to memory | Set in system if required (See Modbus Notes 8 and 9) |

## MODBUS NOTES

- Hex value output from the Error/Warnings input register should be converted to a 6bit binary value. Each bit of the 6bit word represents an error or warning as described in the table below. This method of displaying errors allows multiple errors or warnings to be displayed at the same time.

Example; Hex value = 5, binary representation = 000101, Bit 0 = 1 (Pump Error) and Bit 2 = 1 (Asymmetry Warning).

Note: Only the first 6 bits of the converted Hex value should be used for error detection. Other bits are reserved and maybe used by SST for diagnostics.

| Bit            | Error Description   | Possible Causes  | Description/Actions (Final Action)  |
|----------------|---|--|---|
| Bits [0:5] = 0 | No Error  | System OK  | No Action   |
| Bit [0] = 1    | Sensor Pump Error<br>(Interface forced into Sensor OFF mode)    | Incorrect Sensor Wiring/<br>Damaged Sensor   | <p>Power down the interface. Check the sensor wiring, orientation and connections referring to the Electrical Connections guide on page 4. Check the sensor attached is the correct variant for the selected heater voltage (See page 23).</p> <p>Repower the interface and put the sensor back into ON mode, if the error remains the sensor is no longer functioning correctly which is usually a sign of misuse (See pages 20 and 21). <b>(Replace Sensor)</b></p>   |
| Bit [1] = 1    | Heater Voltage Error<br>(Interface forced into Sensor OFF mode) | <p>Interface Temperature out of Range</p> <p>Measured Heater Voltage out of tolerance for more than 30s.</p> | <p>Ensure ambient temperature has not exceeded the maximum rating of 70°C. Read Pressure Sensor Temperature register and ensure the PCB temperature is below 85°C.</p> <p>Put the sensor back into ON mode and measure the sensor heater voltage during the first 60s across Pins 1 and 2 of the interface (See page 4).</p> <p>If the heater voltage is 0V then remove power from the interface before disconnecting the two sensor heater wires. Repower the interface, restart the sensor then re-measure the heater voltage during the first 60s. If the heater voltage has returned to normal then the sensor heater coil has gone short circuit which can be confirmed with a multimeter <b>(Replace Sensor)</b>.</p> <p>If the heater voltage remains at 0V then the switch mode power supply on the interface has been electrically damaged <b>(Replace Interface)</b>.</p> |
| Bit [2] = 1    | Asymmetry Warning   | Sensor waveform asymmetry out of Specification for more than 30s.  | <p>The value in the Asymmetry input register should be between 0.95 and 1.05 when the sensor is in a steady oxygen concentration. However when the O<sub>2</sub> level is changing the waveform period is also changing so the asymmetry value can vary outside of this range. If the asymmetry value falls outside this range for more than 30s an asymmetry warning will be set. Asymmetry warnings can be generated if the sensor has reached its end of life or has been damaged through misuse (See pages 20 and 21). <b>(Replace Sensor)</b>.</p>   |



## MODBUS NOTES (continued)

| Bit         | Error Description                 | Possible Causes  | Description/Actions (Final Action)  |
|-------------|-----------------------------------|--|---|
| Bit [3] = 1 | O <sub>2</sub> Under 0.1% Warning | Sensor measuring less than 0.1% oxygen for more than 30s.                      | Ensure measuring gas has at least 0.1% oxygen which is essential for correct sensor operation. Sustained use below 0.1% O <sub>2</sub> will cause permanent readout errors. Low oxygen in a reducing atmosphere will accelerate sensor damage. (See pages 20 and 21).   |
| Bit [4] = 1 | Pressure Sensor Warning           | Atmospheric pressure value outside of the specified range for more than 30s.   | <p>Ensure the sensor and interface are being operated within the specified pressure range of 260 to 1260mbar.</p> <p>If the atmospheric pressure is correct then the out of range reading in the Pressure input register may be due to the pressure sensor being damaged either mechanically or by ESD damage due to incorrect handling procedures. <b>(Replace Interface)</b>.</p>   |
| Bit [5] = 1 | Pressure Sensor Error             | Communication with the Pressure Sensor has not been established or has broken. | <p>Communication with the pressure sensor has ceased due to the pressure sensor being damaged either mechanically or by ESD damage due to incorrect handling procedures. <b>(Replace Interface)</b>.</p> <p>When the pressure sensor fails the interface will revert back to a non-pressure compensated oxygen reading to allow continued use of the interface until a suitable time has arisen to replace the interface. In this mode of operation no PPO<sub>2</sub> measurement is available.</p> <p>In this condition the interface will require regular re-calibration to overcome the effects of atmospheric pressure fluctuations. See Modbus note 4 for calibration instructions.</p> |

The error and warning flags can be cleared by setting the Clear Error Flags register to '1'. This register will return to 0 when the clear has been completed.

**MODBUS NOTES (continued)**

2. The shutdown delay allows the heater voltage to remain on after the sensor has stopped taking measurements. This should be used in applications where there is high humidity and especially if there is also aggressive components in the measurement gas (See page 20). By applying a shutdown delay the heater can keep the sensor hot until the rest of the application has cooled down. This encourages condensation to form elsewhere and not on the sensor which could lead to corrosion of the sensing cell. The length of the delay in seconds should be set to suit the application cool down time. The shutdown delay time is stored in memory and retained after power loss.
3. Standby Mode is used when O<sub>2</sub> measurements are infrequent but it is not desirable to wait for the full warm up time experienced going from OFF mode to ON mode. In Standby Mode the heater voltage is reduced to 2V<sub>DC</sub> to decrease power consumption whilst keeping the sensor warm enough to protect it from condensation in humid environments.
4. Calibration should occur when the O<sub>2</sub> sensor has been operating in the calibration gas for at least 5 minutes. At this point the known calibration gas value should be sent to the Calibration (%) holding register (For fresh air input '2070' for 20.70% O<sub>2</sub>) then the Calibration Control register is set to '1'. The interface will only calibrate after the sensor has been in ON mode (heater voltage active) for more than 5 minutes, if a calibration is attempted during this period the calibration process will pause until the 5 minute period has elapsed. The Calibration Status register which will remain at '1' until the calibration process is complete at which point it will change to '2' (Calibration Completed). After a calibration has completed the Calibration Control register can be set to '2' to return the Calibration Status register back to '0' (Calibration Idle) ready for the any future calibrations. New Calibration values are stored in memory and retained on power loss. The value inserted into the Calibration (%) holding register is also stored in memory so does not need to be reinserted before each calibration unless the calibration gas is going to change.
5. The Address register allows the interface slave address to be changed between 1 and 247. This is only applicable if there are multiple OXY-LC-Oxygen Sensor Interfaces or other devices on the same communication lines.
6. The communication settings can be adjusted to suit the application. Changes are only implemented when the RS485 Setup Changes Apply and Save holding register is set to '1'. After applying new settings communications will be lost and the interface will be returned to it's idle state (no O<sub>2</sub> measurements) until the master is reconfigured to the new settings at which point the sensor will have to be switched on again. Any changes made are retained on power loss.
7. Pressure and Pressure Sensor Temperature readings are for indication only. The pressure sensor has a typical accuracy of ±2mbar in the pressure sensor temperature range of 0 to 70°C. As the interface has a switch mode power supply to regulate the sensor heater voltage the pressure sensor temperature can be 10 to 20°C higher than the ambient temperature. The pressure sensor temperature reading is output through Modbus in 2's complement to allow for negative temperatures. For example 20°C would be 20 in decimal, 0x0014 in hex and 000000000010100 in 16 bit binary. -40°C would be 65496 in decimal, 0xFFD8 in hex and 1111111111011000 in 16 bit binary.
8. The heater voltage applied to the sensor can be adjusted to suit the variant of sensor attached. Different sensors require different heater voltages depending on the type of porous filter surrounding the sensing element (determines the response time) and the length of cables between the sensor and interface. A list of the different sensors types and their corresponding heater voltages can be found on page 23. Changes are only implemented when the Heater Voltage Changes Apply and Save holding register is set to '1'. After applying new settings the interface will be returned to it's idle state (no O<sub>2</sub> measurements) and the sensor will have to be switched back on again. Any changes made are retained on power loss.
9. Flash memory has a finite number of allowed writes, use appropriately.

## Section B - Analogue variants

### ELECTRICAL CONNECTIONS

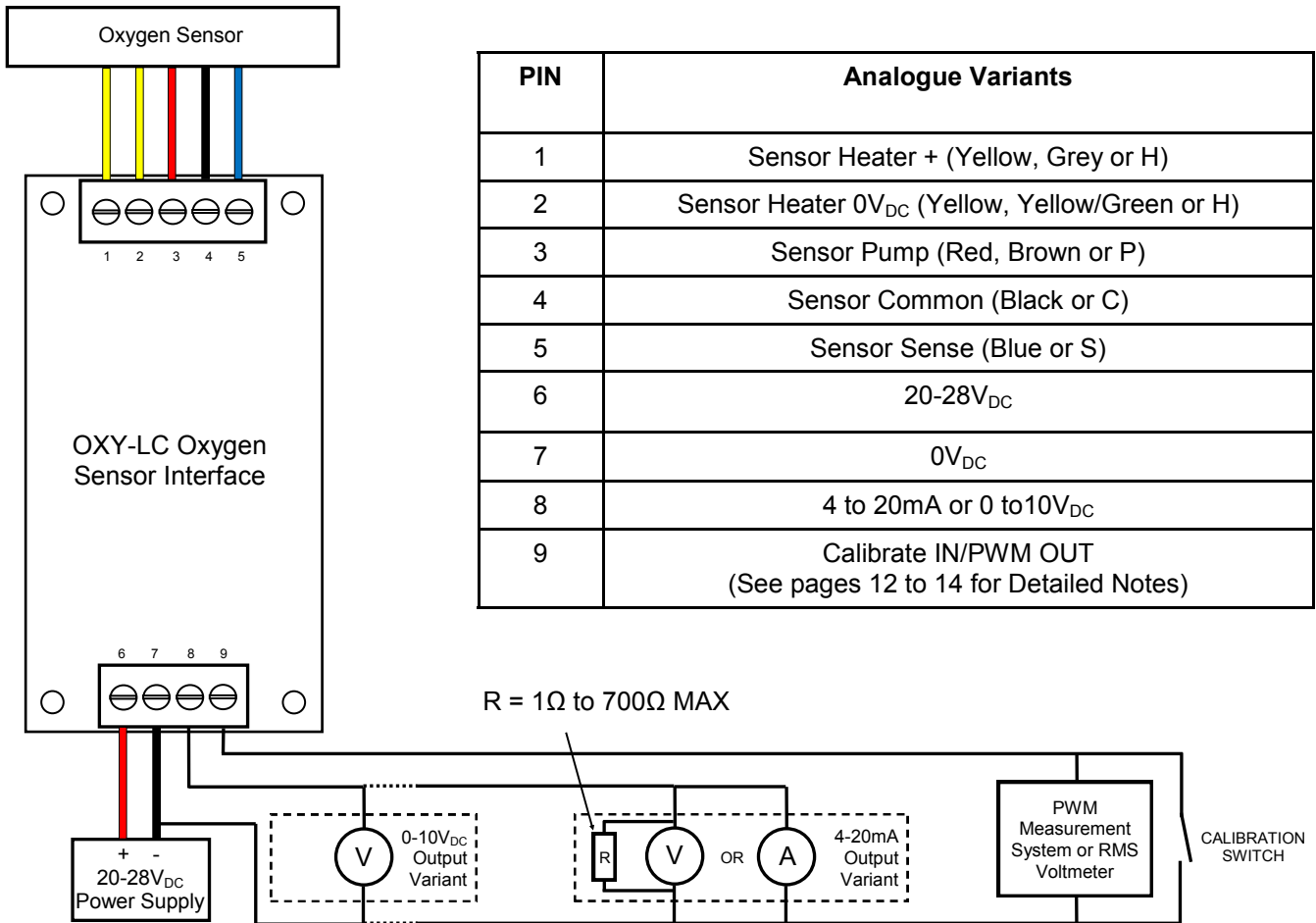

| O <sub>2</sub> % | Output Values              |                           |                          |                           |
|------------------|----------------------------|---------------------------|--------------------------|---------------------------|
|                  | 0-10V <sub>DC</sub> output |                           | 4-20mA output            |                           |
|                  | 0.1 - 25% O <sub>2</sub>   | 0.1 - 100% O <sub>2</sub> | 0.1 - 25% O <sub>2</sub> | 0.1 - 100% O <sub>2</sub> |
| 20.7%            | 8.28V <sub>DC</sub>        | 2.07V <sub>DC</sub>       | 17.25mA                  | 7.34mA                    |
| 100%             | -                          | 10V <sub>DC</sub>         | -                        | 20mA                      |
| 90%              | -                          | 9.0V <sub>DC</sub>        | -                        | 18.4mA                    |
| 25%              | 10V <sub>DC</sub>          | 2.5V <sub>DC</sub>        | 20mA                     | 8mA                       |
| 5%               | 2.0V <sub>DC</sub>         | 0.5V <sub>DC</sub>        | 7.2mA                    | 4.8mA                     |
| 0.1% (See Notes) | 0.04V <sub>DC</sub>        | 0.01V <sub>DC</sub>       | 4.06mA                   | 4.02mA                    |

#### Notes:

- Every SST oxygen sensor has two heater connections which should be connected to pins 1 & 2 of the OXY-LC Oxygen Sensor Interface, the heater coil has no polarity. However when connecting to a sensor where the sensor housing is one of the heater connections (O2S-FR-T4 Range) pin 2 of the OXY-LC Oxygen Sensor Interface should be connected to the housing.
- Pins 8 and 9 are referenced to the power supply 0V<sub>DC</sub> (pin 7). A connection should be made between pin 7 and the reference or common connection of the analogue output measurement system.
- The analogue output ranges actually represent 0 to 25% or 0 to 100% O<sub>2</sub> but as SST's oxygen sensors cannot measure below 0.1% O<sub>2</sub> this value is displayed as the range minimum.

## CALIBRATE IN/PWM OUT NOTES

PWM Output Characteristics:

Frequency: 1kHz:

$V_{out}$  (PWM): 3.3V<sub>DC</sub>

| Duty Cycle (ON Time) | Analogue Output Status  | Error Description              | Possible Causes  | Description/Actions (Final Action)  |
|----------------------|---|--------------------------------|--|---|
| 25%                  | Proportional to O <sub>2</sub>  | No Error                       | System OK  | No Action   |
| 50%                  | 4mA or 0Vdc (Interface is forced into an idle state and analogue outputs go to their minimum value) | System Error for more than 30s | Interface Over Temperature<br><br>Sensor Heater Short or Heater Voltage Supply Damaged | <p>Power down the interface. Check all wiring, orientations and measurement connections as described in Electrical Connections on page 11.</p> <p>Ensure ambient temperature has not exceeded the maximum rating.</p> <p>Power cycle the interface supply voltage and measure the sensor heater voltage during the first 60s across Pins 1 and 2 of the interface . If the heater voltage is 0V then remove the power again before disconnecting the two sensor heater wires. Repower the interface and re-measure the heater voltage during the first 60s. If the heater voltage has returned to normal then the sensor heater coil has gone short circuit which can be confirmed with a multimeter <b>(Replace Sensor)</b>.</p> <p>If the heater voltage remains at 0V then the switch mode power supply on the interface has been electrically damaged <b>(Replace Interface)</b>.</p>   |
| 50%                  | Proportional to O <sub>2</sub> (Interface continues to operate with possible output errors)         | System Error for more than 30s | Analogue Output Error<br><br>Pressure Sensor Warning/Error                             | <p>Power down the interface. Check all wiring, orientations and measurement connections/ loads as described in Electrical Connections on page 11. Retest the analogue output and PWM status to see if the error condition has been resolved.</p> <p>Ensure the sensor and interface are being operated within the specified pressure range of 260 to 1260mbar. If the atmospheric pressure range is ok, the pressure sensor has been damaged either mechanically or by ESD damage due to incorrect handling procedures. <b>(Replace Interface)</b>.</p> <p>When the pressure sensor fails the interface will revert back to a non-pressure compensated oxygen reading to allow continued use of the interface until a suitable time has arisen to replace the interface.</p> <p>In this condition the interface will require regular re-calibration to overcome the effects of atmospheric pressure fluctuations. See Page 14 for calibration instructions.</p> |

## CALIBRATE IN/PWM OUT NOTES

| Duty Cycle (ON Time) | Analogue Output Status  | Error Description              | Possible Causes   | Description/Actions (Final Action)   |
|----------------------|---|--------------------------------|---|--|
| 75%                  | 4mA or 0Vdc (Interface is forced into an idle state and analogue outputs go to their minimum value) | Sensor Error for more than 30s | Sensor Pump Failure   | Power down the interface. Check the sensor wiring, orientation and connections. Check the sensor attached is the correct variant for the selected heater voltage. Repower the interface, if the error remains the sensor is no longer functioning correctly which is usually a sign of misuse (See pages 20 and 21).<br><b>(Replace Sensor)</b>  |
| 75%                  | Proportional to O <sub>2</sub> (Interface continues to operate with possible output errors)         | Sensor Error for more than 30s | Asymmetry Error<br><br>Measurement < 0.1% O <sub>2</sub>  | Power down the interface. Check the sensor wiring, orientation and connections. Check the sensor attached is the correct variant for the selected heater voltage. Repower the interface, if the error remains the sensor is no longer functioning correctly. Asymmetry warnings can be generated if the sensor has reached its end of life or has been damaged through misuse (See pages 20 and 21).<br><b>(Replace Sensor)</b> .<br><br>Ensure measuring gas has at least 0.1% oxygen which is essential for correct sensor operation. Sustained use below 0.1% O <sub>2</sub> will cause permanent readout errors. Low oxygen in a reducing atmosphere will accelerate the sensor damage. (See page 21). |
| 0 or 100%            |   | System Failure                 | Interface not powered correctly or irreversibly damaged<br><br>PWM output not connected to PWM measurement system correctly | Check all wiring and ensure the supply voltage is within the specified limits. Check the power supply is capable of supplying the required current. <b>(Replace Interface)</b> .<br><br>Check all wiring and ensure the 0V <sub>DC</sub> of the interface is common to that of the measurement systems.  |

## CALIBRATE IN/PWM OUT NOTES

### PWM Output Schematic:

The following PWM output schematic can be used as reference when connecting to suitable measurement system:

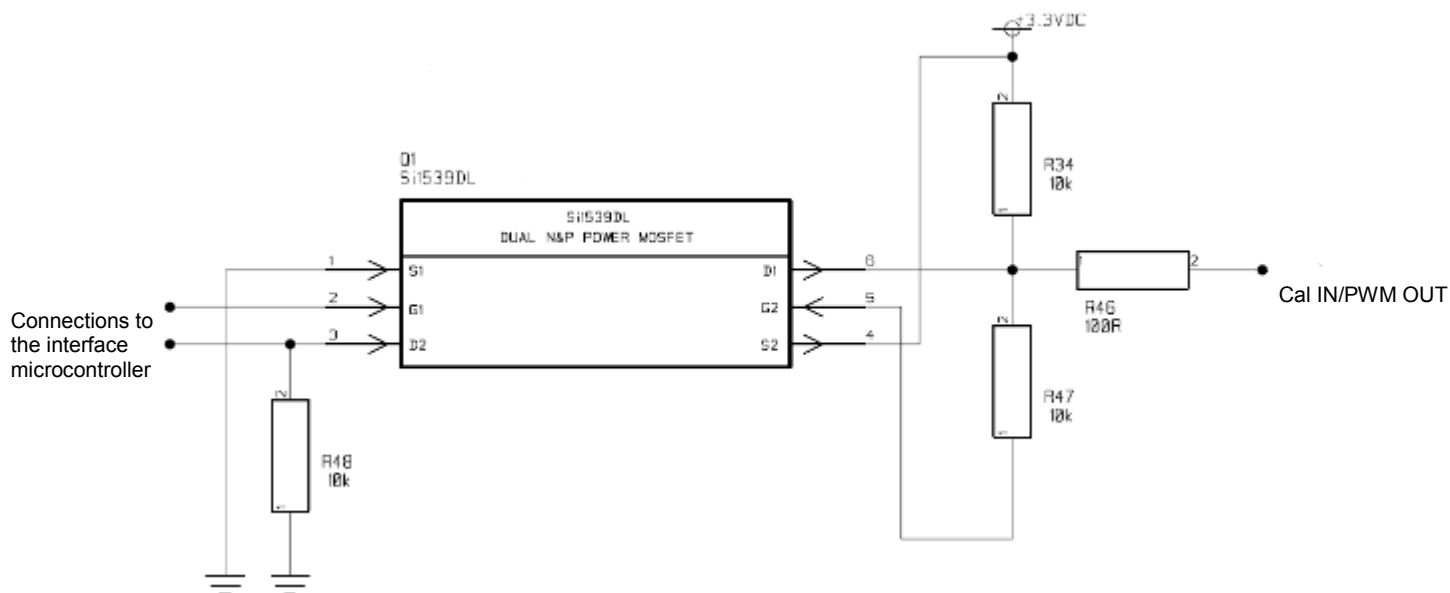

### PWM Measurement System Requirements:

Frequency Measurement: 3.3V<sub>DC</sub> compatible input. Minimum sample frequency of 8kHz.

Alternative RMS Voltage measurement: Any RMS input voltmeter. RMS Voltage vs Duty Cycle is as follows.

| Duty Cycle (ON Time) | Approximate RMS Voltage |
|----------------------|-------------------------|
| 0%                   | 0V <sub>DC</sub>        |
| 25%                  | 0.83V <sub>DC</sub>     |
| 50%                  | 1.65V <sub>DC</sub>     |
| 75%                  | 2.48V <sub>DC</sub>     |
| 100%                 | 3.3V <sub>DC</sub>      |

### Calibration routine:

As shown on page 11 a calibration switch is used to connect the Cal IN/PWM OUT output to 0V<sub>DC</sub>. When the switch is closed (for a minimum of 1s) the interface will calibrate the analogue output as outlined in the table below. The switch could either be a mechanical switch, a relay contact, a NPN transistor or a N-Channel MOSFET. If a calibration is attempted in the first 5 minutes after the interface has been powered the calibration will be delayed until the 5 minutes have elapsed. This ensures the sensor has fully warmed up and avoids incorrect calibrations. Ensure the sensor has been operating in the calibration gas for at least 5 minutes before attempting a calibration.

| Analogue Output Variant   | Output Calibrated to/Required Calibration Gas |
|---------------------------|---|
| 0.1 - 25% O <sub>2</sub>  | 20.7% O <sub>2</sub> /Normal Air              |
| 0.1 - 100% O <sub>2</sub> | 100% O <sub>2</sub> /Pure Oxygen              |

**GENERAL OPERATING OVERVIEW**

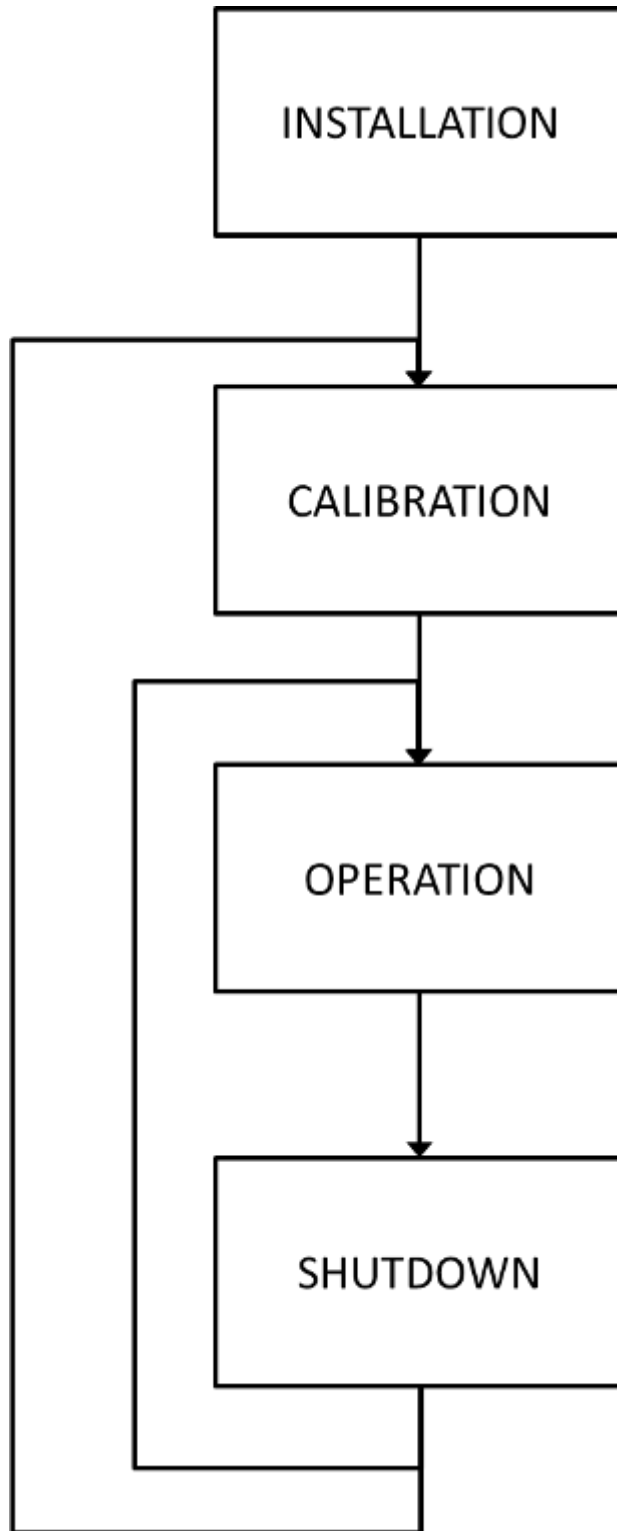

**INSTALLATION PROCEDURE**

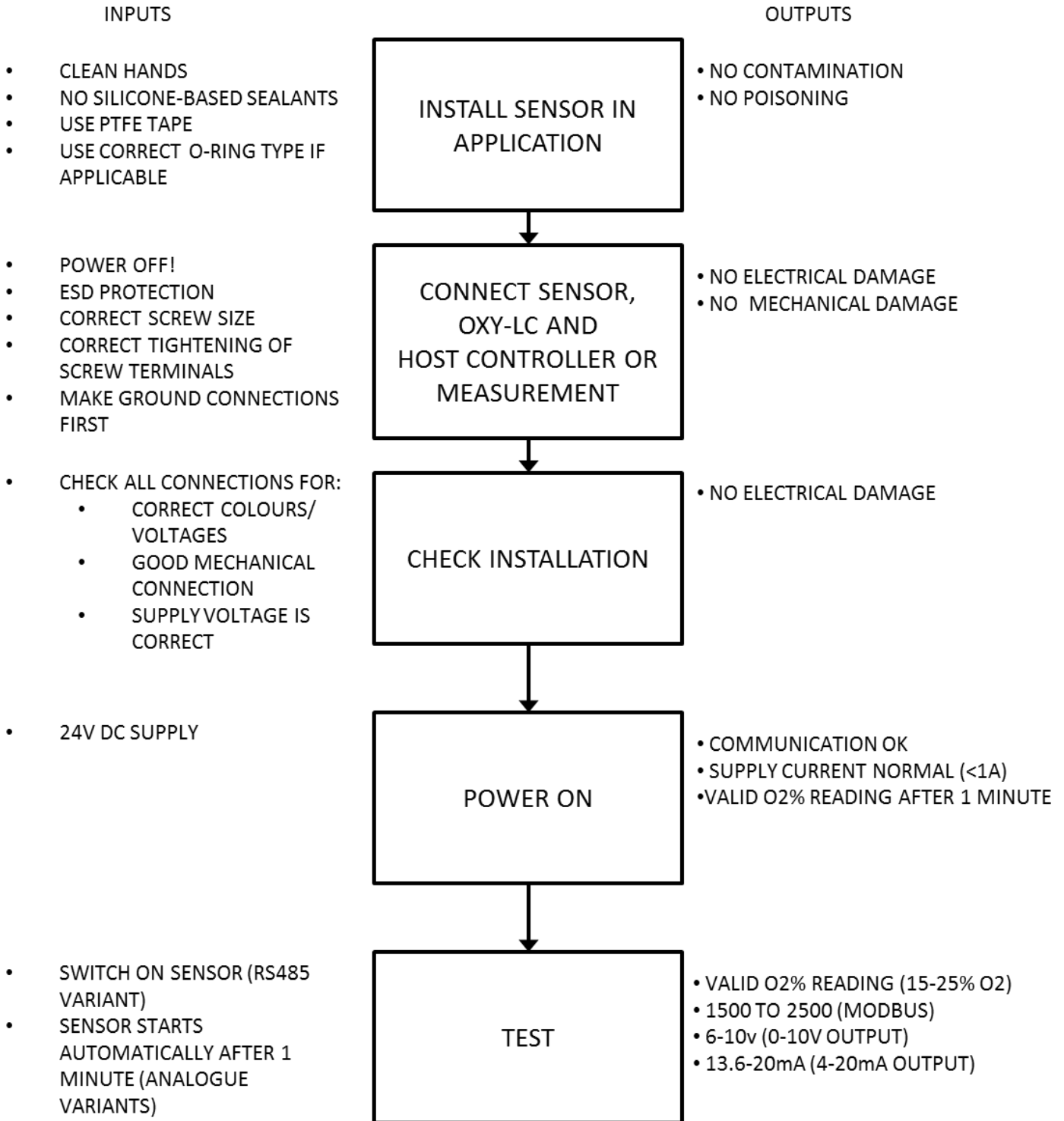



**CALIBRATION PROCEDURE**

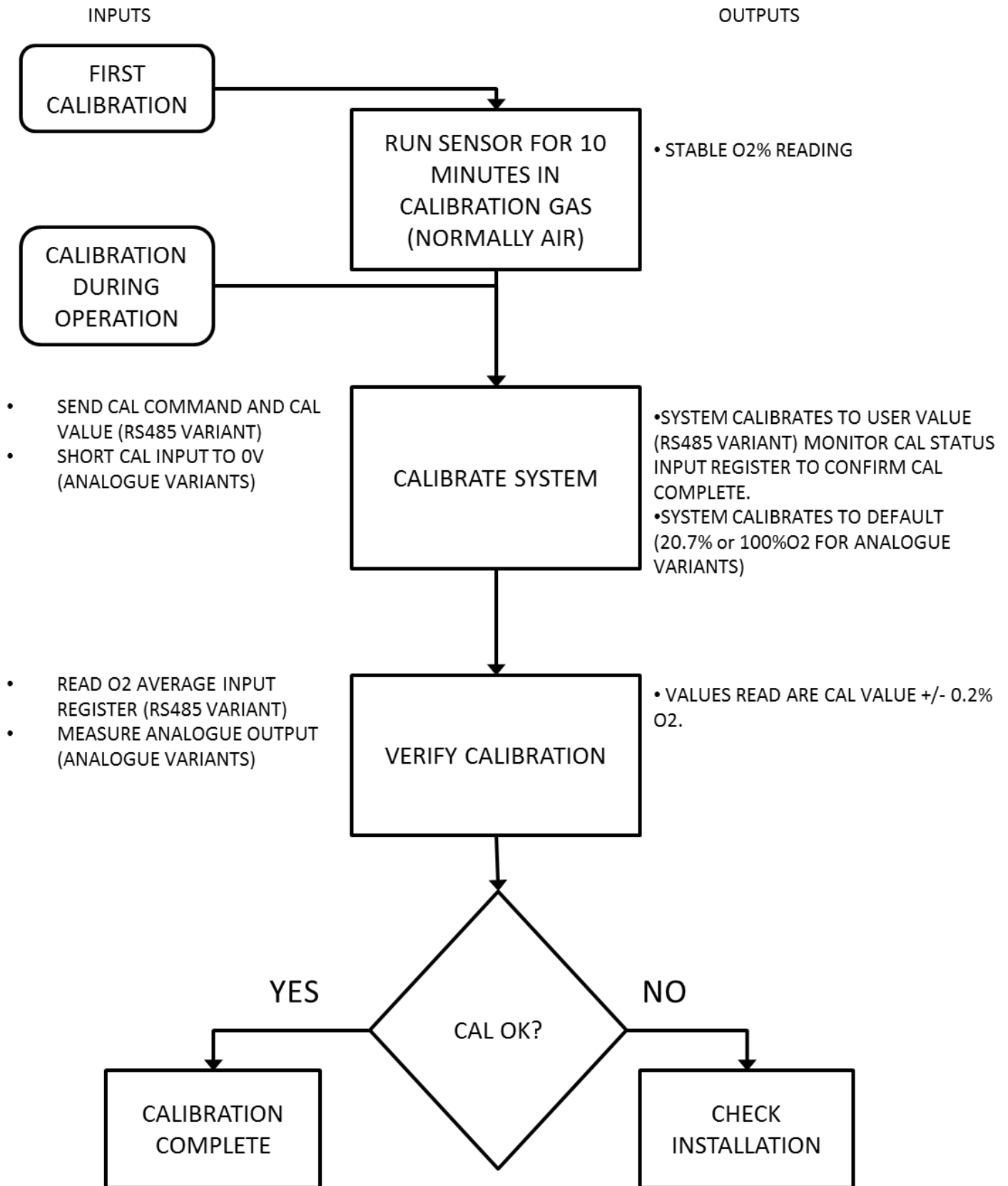

**NORMAL OPERATION DIAGNOSTICS ROUTINE**

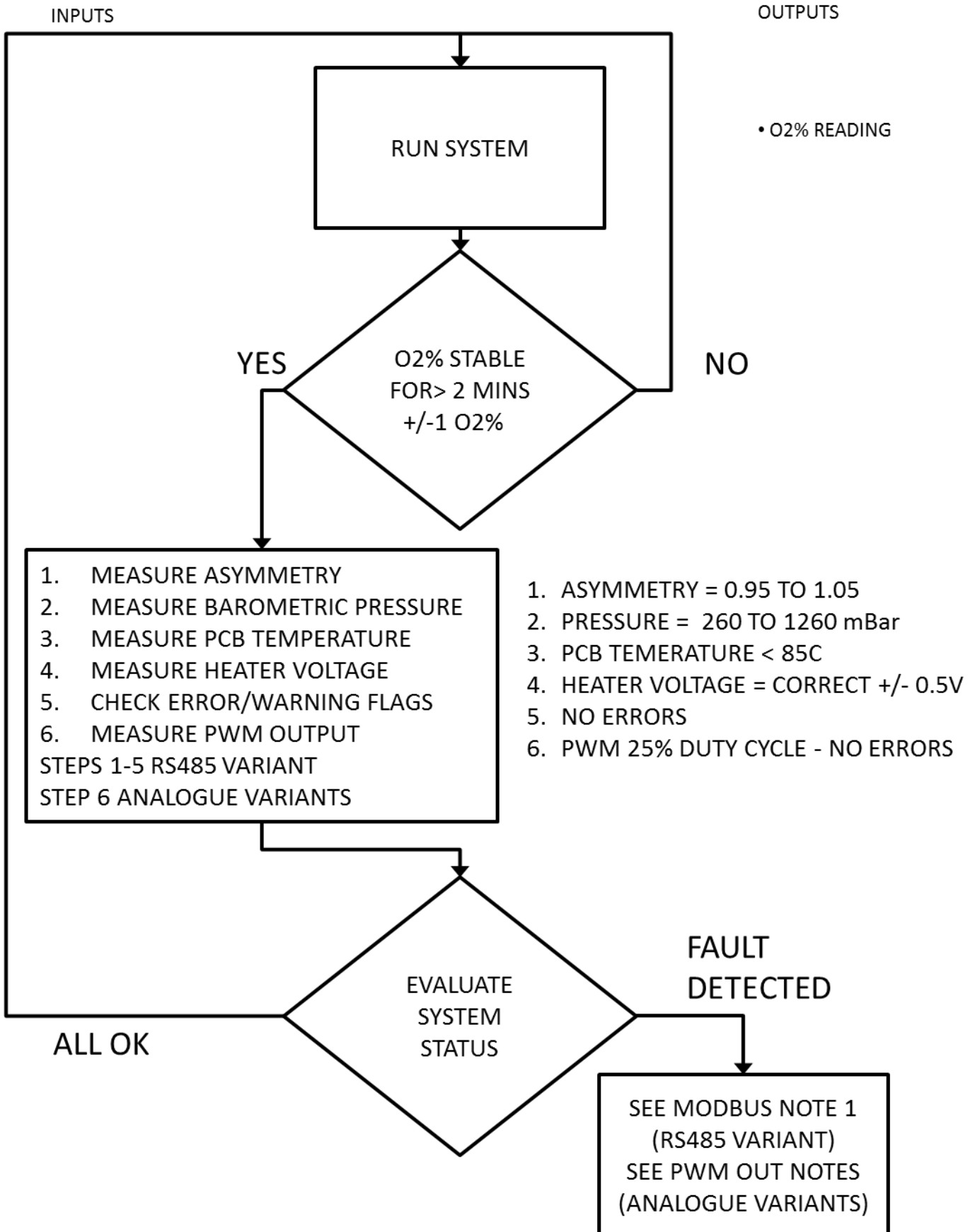

SHUTDOWN PROCEDURE (RS485 VARIANT ONLY)

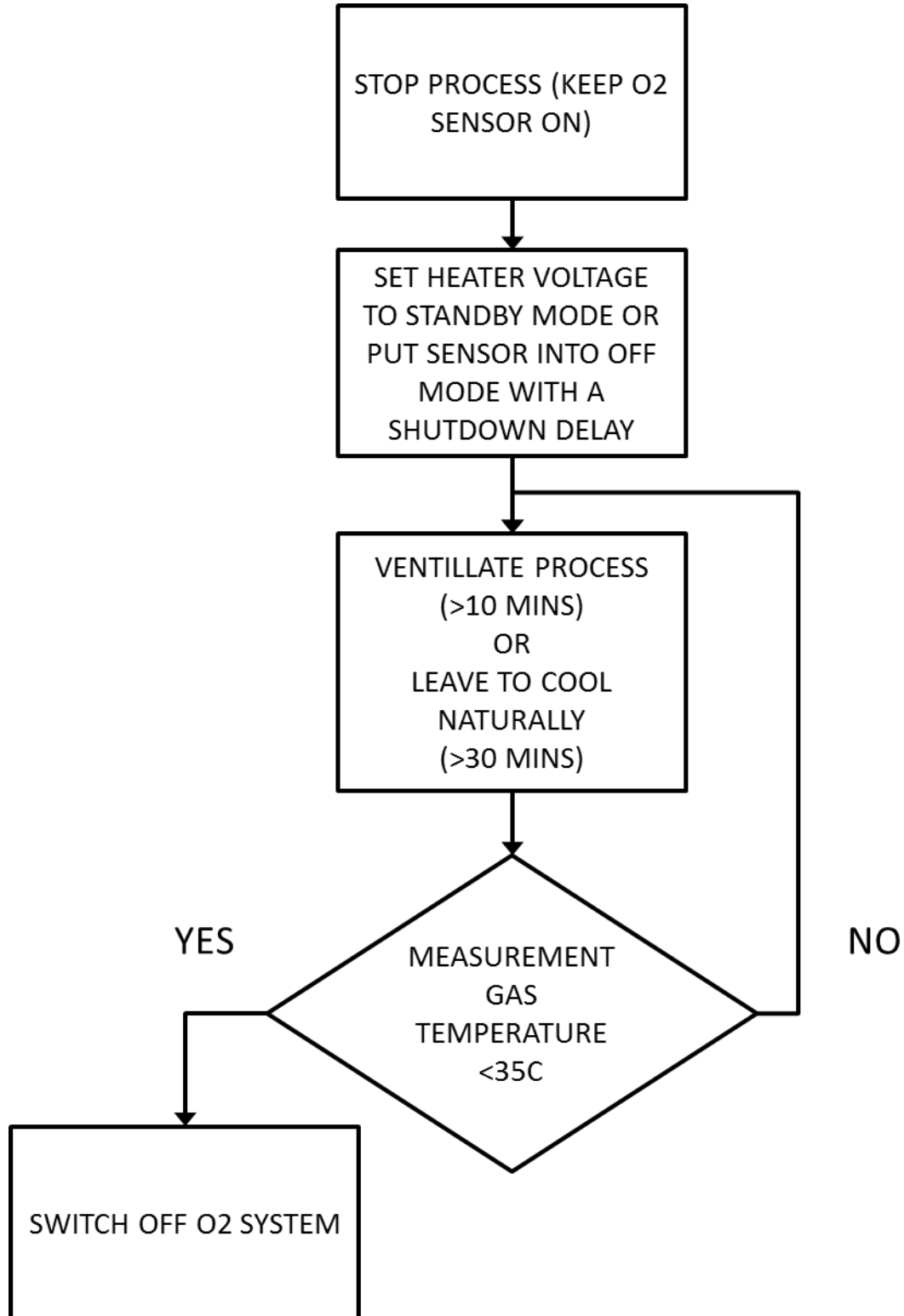

## SENSOR OPERATING TIPS

To get the best performance from the OXY-LC Oxygen Sensor Interface it is important that the attached oxygen sensor is installed and maintained in the correct manner. The following two pages outline some useful sensor operating tips and a list of gases and materials that must be avoided to ensure a long sensor life.

### Operating the Sensor in Aggressive Humid Environments:

When operating the sensor in warm, humid environments it is important the sensor remains at a higher temperature than its surroundings, especially if there are corrosive components in the measurement gas. During operation this is not a problem due to the 700°C generated by the heater, but this means when the sensor or application is being powered down the sensor heater must be the last thing to be turned off after the temperature of the surroundings have suitably cooled. Ideally the sensor should be left powered at all times in very humid environments.

Failure to adhere to the above will result in condensation forming on the heater and sensing cell as these will be the first components to cool due to their connections to the outside world. When the sensor is re-powered the condensation will evaporate, leaving behind corrosive salts which very quickly destroy the heater and cell as illustrated below. Note how the sensor's external metalwork looks completely normal.



### Protecting from Water Droplets:

In environments where falling water droplets are likely the sensor should be protected from water falling directly onto the very hot sensor cap as this can cause massive temperature shocks to the cell and heater. Popular methods include a hood over the sensor cap or for the sensor to be mounted in a larger diameter cylinder.

At a very minimum the sensor cap should be angled downwards in the application as this will deflect any falling moisture and prevent the sensor cap from filling with water.

### Using the Sensor With Silicones:

SST Sensing's oxygen sensors, like all other Zirconium Dioxide sensors, are damaged by the presence of silicone in the measurement gas. Vapours (organic silicone compounds) of RTV rubbers and sealants are the main culprits and are widely used in many applications. These materials which are often applied as a liquid or gel still outgas silicone vapours into the surrounding atmosphere even after they have cured. When these vapours reach the sensor the organic part of the compound will be burned at hot sensor parts, leaving behind a very fine divided Silicon Dioxide ( $\text{SiO}_2$ ). This  $\text{SiO}_2$  completely blocks the pores and active parts of the electrodes.

If silicone cannot be avoided in the application we advise using high quality, high temperature cured materials which do not outgas when subsequently heated. SST can provide guidance if there is concern about use of silicone within the application.

When installing the sensor do not use any lubricants or grease which may contain silicone.

In addition to silicones other gases which may interfere with the sensor are listed overleaf.

## SENSOR OPERATING TIPS continued

### Cross sensitivity with other gases:

Gases or chemicals that will have an influence on the life of the sensor or on the measuring results are:

#### 1. Combustible Gases

Small amounts of combustible gases will be burned at the hot Pt-electrode surfaces or Al<sub>2</sub>O<sub>3</sub> filters of the sensor. In general combustion will be stoichiometric as long as enough oxygen is available, the sensor will measure the residual oxygen pressure which leads to a measurement error. The sensor is not recommended for use in applications where there are large amounts of combustible gases present and an accurate O<sub>2</sub> measurement is required.

Investigated gases were:

- H<sub>2</sub> (Hydrogen) up to 2%; stoichiometric combustion
- CO (Carbon Monoxide) up to 2%; stoichiometric combustion
- CH<sub>4</sub> (Methane) up to 2.5%; stoichiometric combustion
- NH<sub>3</sub> (Ammonia) up to 1500 ppm; stoichiometric combustion

#### 2. Heavy Metals

Vapours of metals like Zn (Zinc), Cd (Cadmium), Pb (Lead), Bi (Bismuth) will have an effect on the catalytic properties of the Pt- electrodes. Exposure to these metal vapours must be avoided.

#### 3. Halogen and Sulphur Compounds

Small amounts (< 100ppm) of Halogens and/or Sulphur compounds have no effect on the performance of the oxygen sensor. Higher amounts of these gases will in time cause readout problems or, especially in condensing atmospheres, corrosion of sensor parts. These gases often outgas from plastic housings and tubes when hot.

Investigated gases were:

- Halogens, F<sub>2</sub> (Fluorine), Cl<sub>2</sub> (Chlorine)
- HCL (Hydrogen Chloride), HF (Hydrogen Fluoride)
- SO<sub>2</sub> (Sulphur Dioxide)
- H<sub>2</sub>S (Hydrogen Sulphide)
- Freons
- CS<sub>2</sub> (Carbon Disulfide)

#### 4. Reducing Atmospheres

Long time exposure to reducing atmospheres may in time impair the catalytic effect of the Pt-electrodes and has to be avoided. Reducing atmospheres are defined as an atmosphere with very little free oxygen and where combustible gases are present. In this type of atmosphere oxygen is consumed as the combustible gases are burned.

#### 5. Others

- Dust. Fine dust (Carbon parts/soot) might cause clogging of the porous stainless steel filter and might have an effect on the response of the sensor to oxygen changes.
- Heavy shocks or vibrations may alter sensor properties resulting in the need for a recalibration.

## OUTLINE DRAWING AND MOUNTING INFORMATION (All dimensions are in mm)

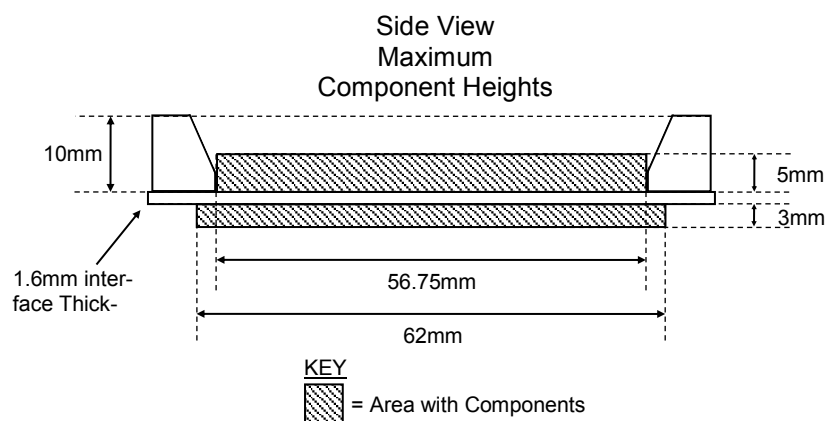
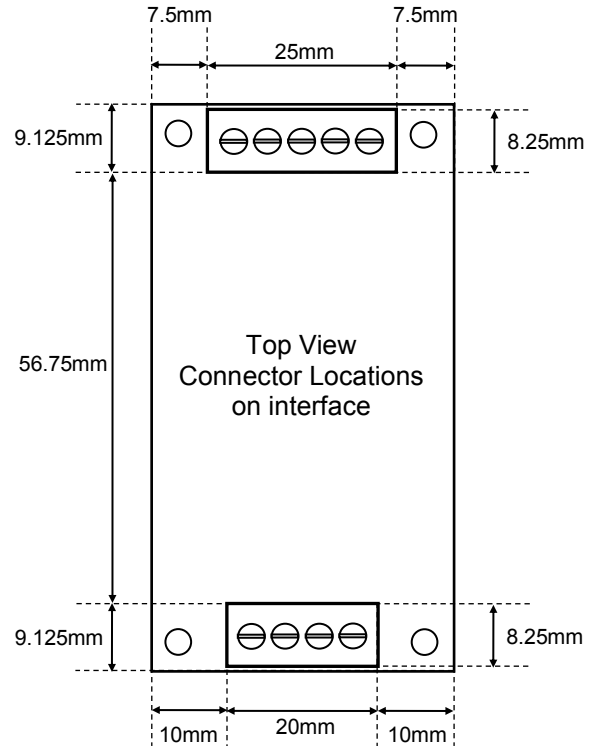
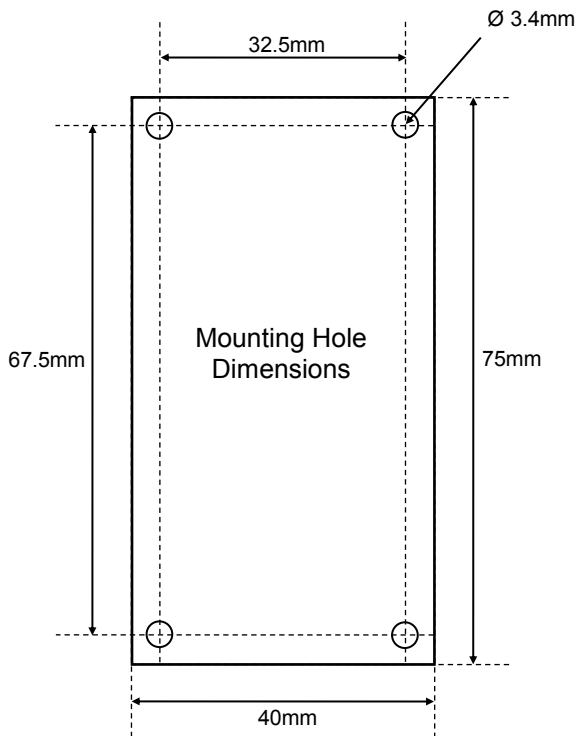

**ORDERING INFORMATION.**

| Part Number     | O2 Measurement range (vol O <sub>2</sub> %) | Output Type     | Heater Voltage (to suit sensor type and cable length) | For sensor type   |  |
|-----------------|---|-----------------|---|---|--|
| OXY-LC-485      | 0.1% to 100%                                | Modbus RTU      | Adjustable Default (4.35V)                            | Standard and Fast response sensors with any cable length up to 1m |  |
| OXY-LC-A25-400  | 0.1 to 25%                                  | Current: 4-20mA | 4.00V   | Standard response time, short cable (<150mm)                      |  |
| OXY-LC-A25-420  |   |                 | 4.20V   | Standard response time, long cable (>150mm)                       |  |
| OXY-LC-A25-435  |   |                 | 4.35V   | Fast response time, short cable (<150mm)                          |  |
| OXY-LC-A25-455  |   |                 | 4.55V   | Fast response time, long cable (>150mm)                           |  |
| OXY-LC-A100-400 | 0.1 to 100%                                 |                 | 4.00V   | Standard response time, short cable (<150mm)                      |  |
| OXY-LC-A100-420 |   |                 | 4.20V   | Standard response time, long cable (>150mm)                       |  |
| OXY-LC-A100-435 |   |                 | 4.35V   | Fast response time, short cable (<150mm)                          |  |
| OXY-LC-A100-455 |   |                 | 4.55V   | Fast response time, long cable (>150mm)                           |  |
| OXY-LC-V25-400  | 0.1 to 25%                                  |                 | Voltage: 0-10V  | 4.00V   | Standard response time, short cable (<150mm) |
| OXY-LC-V25-420  |   |                 |   | 4.20V   | Standard response time, long cable (>150mm)  |
| OXY-LC-V25-435  |   |                 |   | 4.35V   | Fast response time, short cable (<150mm)     |
| OXY-LC-V25-455  |   |                 |   | 4.55V   | Fast response time, long cable (>150mm)      |
| OXY-LC-V100-400 | 0.1 to 100%                                 | 4.00V           |   | Standard response time, short cable (<150mm)                      |  |
| OXY-LC-V100-420 |   | 4.20V           |   | Standard response time, long cable (>150mm)                       |  |
| OXY-LC-V100-435 |   | 4.35V           |   | Fast response time, short cable (<150mm)                          |  |
| OXY-LC-V100-455 |   | 4.55V           |   | Fast response time, long cable (>150mm)                           |  |

**General Note:** SST Sensing Ltd reserves the right to make changes in product specifications without notice or liability. All information is subject to SST's own data and considered accurate at time of going to print.

|  |   |
|--|---|
| <p><b>WARNING</b></p> <p>All SST Sensing Ltd products are tested under nominal operating conditions during the production process. Applications for our products are varied and, as these are outside our control, specification information provided is given without legal responsibility. Customers should test under their own conditions, to ensure that the sensors are suitable for their intended application.</p> | <p><b>CAUTION</b></p> <p>Do not exceed maximum ratings. Carefully follow all wiring instructions, incorrect wiring can cause permanent damage to the device. Do not use chemical cleaning agents.</p> <p><b>Failure to comply with these instructions may result in product damage.</b></p> |
|--|---|

## X-ON Electronics

Largest Supplier of Electrical and Electronic Components

*Click to view similar products for [Air Quality Sensors](#) category:*

*Click to view products by [SST Sensing](#) manufacturer:*

Other Similar products are found below :

[GMS-MSTH2.S.V.3](#) [MO86571](#) [MO86561](#) [076074 01](#) [DE800.A.1](#) [MF010-2-LC1](#) [MF020-2-LC3](#) [KGZ10-5PIN](#) [GMS10SENSORS](#) [IR25TT](#)  
[208280-0001](#) [IR11BD](#) [IR11GM](#) [IR12GM](#) [IR21BD](#) [GMS10-18C](#) [KGZ12](#) [S-300L-3V-5000-SLEEP-UART](#) [MP7227-TC](#) [OXY-LC-A25-455](#)  
[SGPC3-TR-2.5KS](#) [T6713-6H](#) [POLOLU-1482](#) [3.000.475](#) [3.000.496](#) [HPMA115S0-XXX](#) [SGPC3-2.5k](#) [SGP30-2.5k](#) [T3032-2-10K-24-P](#)  
[VQ6MB](#) [INIR-CD-5%](#) [VQ23TB](#) [IR11GJ](#) [VQ31MB](#) [IR11BR](#) [GP2Y1026AU0F](#) [VQ549ZD](#) [MHM501-00](#) [MHM500-00A](#) [MHM305-01](#)  
[MICS-4514](#) [VQ548ZD-S](#) [SEN-09403](#) [IR15TT](#) [MICS-5524](#) [MICS-5914](#) [MICS-2714](#) [INIR-ME-100%](#) [T8100-D](#) [VQ21TB](#)