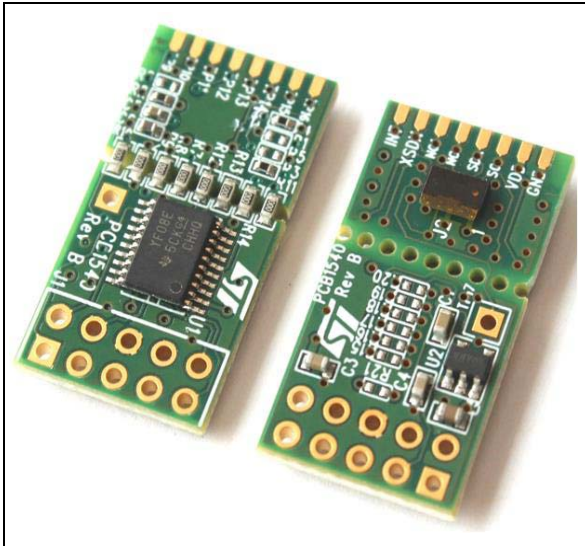

Satellite boards based on VL53L0X ranging and gesture detection sensor

Data brief

**Description**

Satellite board can be used for easy integration into customer devices and basic gesture detection applications.

Thanks to its 2.8V regulator and level shifters, the VL53L0X satellite board can be used in any application with a 2.8 to 5V supply.

The PCB section supporting the VL53L0X module is perforated so that developers can break off the mini PCB for use in a 2.8V supply application using flying leads.

This makes it easier to integrate into development and evaluation devices due to its small form factor.

Features

- Two satellite boards, integrating:
 - VL53L0X 3-in-1 ranging and gesture detection sensor
 - Regulator: 5 to 2.8V range input voltage (output voltage: 2.8V)
 - VL53L0X signal interface level shifter
- True distance measurement independent of target size and reflectance
- Able to function in multi-module applications
- Divisible board enabling use as mini-PCB breakout board, easy to integrate in customer device
- Allows basic gesture recognition use case

VL53L0X Overview

The VL53L0X is the latest product based on ST's patented FlightSense™ technology. This is a ground-breaking technology allowing absolute distance to be measured independent of target reflectance.

Instead of estimating the distance by measuring the amount of light reflected back from the object (which is significantly influenced by color and surface), the VL53L0X precisely measures the time the light takes to travel to the nearest object and reflect back to the sensor (Time-of-Flight).

Combining an IR emitter and a range sensor, the VL53L0X is easy to integrate and saves OEMs long and costly optical and mechanical design optimizations.

The module is designed for low-power operation. Ranging measurements can be automatically performed at user defined intervals.

Multiple threshold and interrupt schemes are supported to minimize host operations.

Note: The VL53L0X is delivered with a liner, in order to prevent potential foreign material to penetrate inside the modules holes during assembly process. It must be removed at the latest possible step during final assembly, and anyway before module calibration.

Divisible board

For 2.8V supply application, the satellite board can be divided along the red dotted line as shown in [Figure 1](#), in order to only use the "mini PCB", Which is easier to integrate into a customer device due to its small form factor.

Figure 1. Satellite board layout

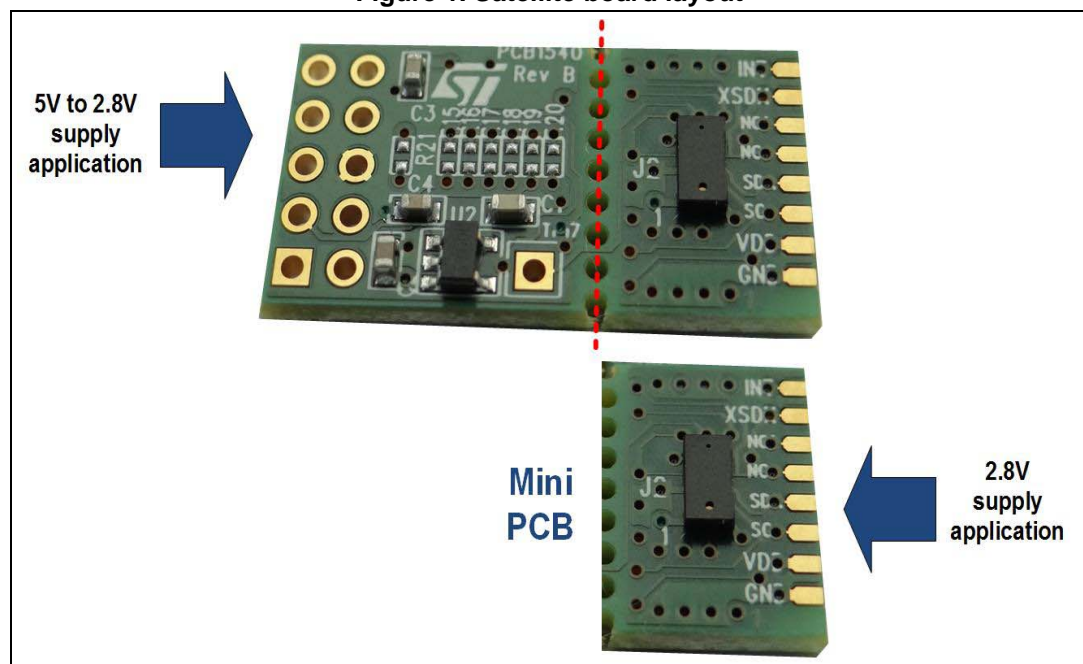

Schematic and list of material

Figure 2. Satellite schematic and list of materials

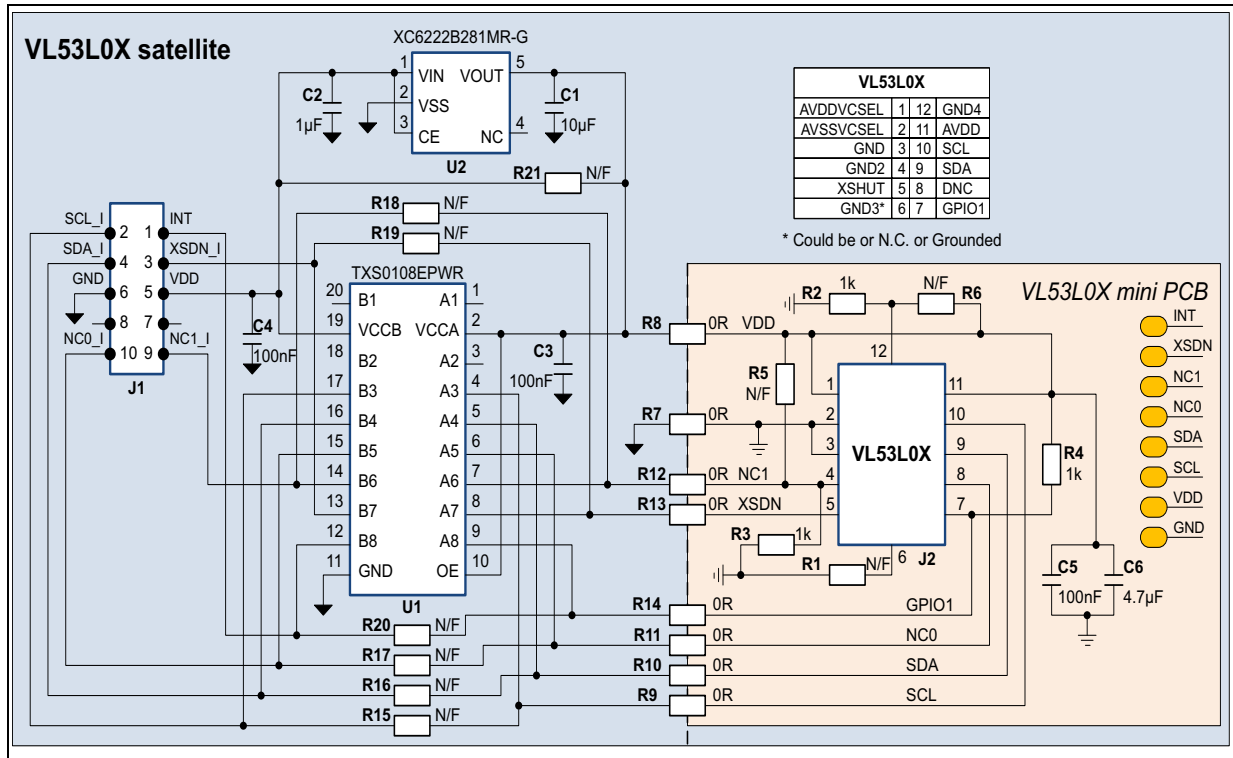

Ordering information

Table 1. Ordering information

Order code	Description
53L0-SATEL-I1	Two VL53L0X satellite boards

Revision history

Table 2. Document revision history

Date	Revision	Changes
2-May-2016	1	Initial release.

IMPORTANT NOTICE – PLEASE READ CAREFULLY

STMicroelectronics NV and its subsidiaries ("ST") reserve the right to make changes, corrections, enhancements, modifications, and improvements to ST products and/or to this document at any time without notice. Purchasers should obtain the latest relevant information on ST products before placing orders. ST products are sold pursuant to ST's terms and conditions of sale in place at the time of order acknowledgement.

Purchasers are solely responsible for the choice, selection, and use of ST products and ST assumes no liability for application assistance or the design of Purchasers' products.

No license, express or implied, to any intellectual property right is granted by ST herein.

Resale of ST products with provisions different from the information set forth herein shall void any warranty granted by ST for such product.

ST and the ST logo are trademarks of ST. All other product or service names are the property of their respective owners.

Information in this document supersedes and replaces information previously supplied in any prior versions of this document.

© 2016 STMicroelectronics – All rights reserved

X-ON Electronics

Largest Supplier of Electrical and Electronic Components

Click to view similar products for [Distance Sensor Development Tool](#) category:

Click to view products by [STMicroelectronics](#) manufacturer:

Other Similar products are found below :

[SEN0004](#) [MIKROE-2509](#) [172](#) [DFR0315](#) [SEN0006](#) [SEN0007](#) [SEN0008](#) [SEN0187](#) [SEN0202](#) [SEN0208](#) [DM160234](#) [SEN0143](#) [3316](#) [SEN-08504](#) [SEN-08502](#) [DFR0445](#) [3317](#) [984](#) [SEN0014](#) [SEN0001](#) [SEN0171](#) [3942](#) [979](#) [981](#) [982](#) [985](#) [AFBR-S50MV85G-EK](#) [TMF8701-DB](#) [TMF8801-DB](#) [TMF8801-EVM](#) [AD8283CP-EBZ](#) [AD8285CP-EBZ](#) [ADUX1020-EVAL-SDP](#) [SEN0245](#) [EVALBGT24LTR22TOBO1](#) [DM160238](#) [MIKROE-3339](#) [MIKROE-3439](#) [MIKROE-1589](#) [MIKROE-1991](#) [MIKROE-2086](#) [MIKROE-3103](#) [SECO-RANGEFINDER-GEVK](#) [PIM058](#) [PIM062](#) [PIM373](#) [101020083](#) [101020353](#) [101020532](#) [101020617](#)