



# 74LVX16373

## LOW VOLTAGE CMOS 16-BIT D-TYPE LATCH (3-STATE) WITH 5V TOLERANT INPUTS

- HIGH SPEED :  
 $t_{PD} = 5.4 \text{ ns (MAX.) at } V_{CC} = 3V$
- 5V TOLERANT INPUTS
- POWER DOWN PROTECTION ON INPUTS
- INPUT VOLTAGE LEVEL:  
 $V_{IL} = 0.8V, V_{IH} = 2V \text{ at } V_{CC} = 3V$
- LOW POWER DISSIPATION:  
 $I_{CC} = 4 \mu A \text{ (MAX.) at } T_A = 25^\circ C$
- LOW NOISE:  
 $V_{OLP} = 0.3V \text{ (TYP.) at } V_{CC} = 3.3V$
- SYMMETRICAL OUTPUT IMPEDANCE:  
 $|I_{OH}| = I_{OL} = 4 \text{ mA (MIN) at } V_{CC} = 3V$
- BALANCED PROPAGATION DELAYS:  
 $t_{PLH} \approx t_{PHL}$
- OPERATING VOLTAGE RANGE:  
 $V_{CC(OPR)} = 2V \text{ to } 3.6V \text{ (1.2V Data Retention)}$
- PIN AND FUNCTION COMPATIBLE WITH 74 SERIES 16373
- IMPROVED LATCH-UP IMMUNITY

### DESCRIPTION

The 74LVX16373 is a low voltage CMOS 16 BIT D-TYPE LATCH with 3 STATE OUTPUTS NON INVERTING fabricated with sub-micron silicon gate and double-layer metal wiring C<sup>2</sup>MOS technology. It is ideal for low power, battery operated and low noise 3.3V applications.

These 16 bit D-TYPE latches are byte controlled by two latch enable inputs (nLE) and two output enable inputs(OE).

While the nLE input is held at a high level, the nQ outputs will follow the data input precisely.

When the nLE is taken LOW, the nQ outputs will be latched precisely at the logic level of D input data.

While the (nOE) input is low, the nQ outputs will be in a normal logic state (high or low logic level) and while high level the outputs will be in a high impedance state.

Power down protection is provided on all inputs and 0 to 7V can be accepted on inputs with no regard to the supply voltage.

This device can be used to interface 5V to 3V. It combines high speed performance with the true CMOS low power consumption.

All inputs and outputs are equipped with protection circuits against static discharge, giving them 2KV ESD immunity and transient excess voltage.

February 2003



### ORDER CODES

| PACKAGE | TUBE | T & R         |
|---------|------|---------------|
| TSSOP   |      | 74LVX16373TTR |

### PIN CONNECTION

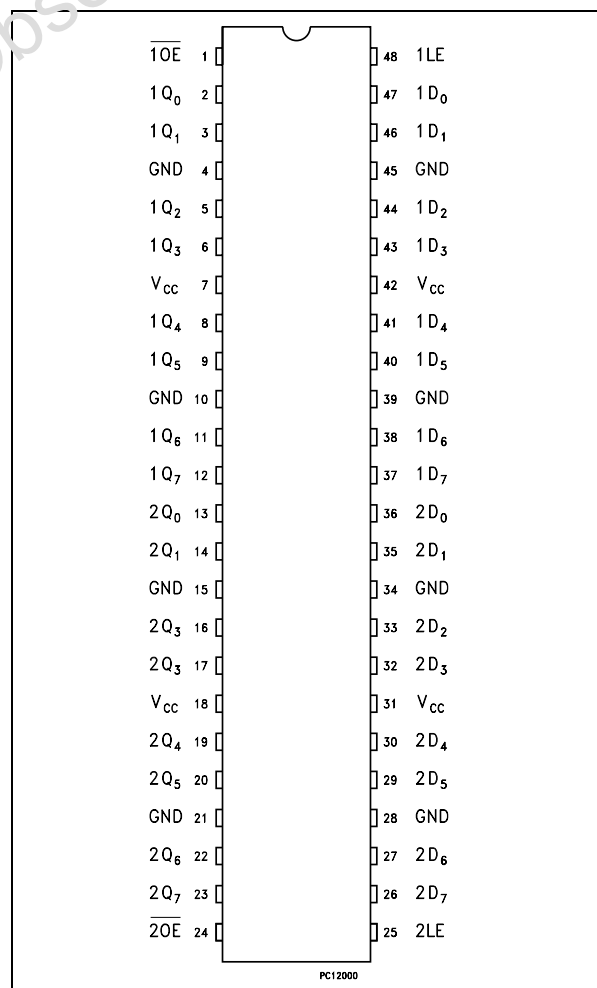

INPUT EQUIVALENT CIRCUIT

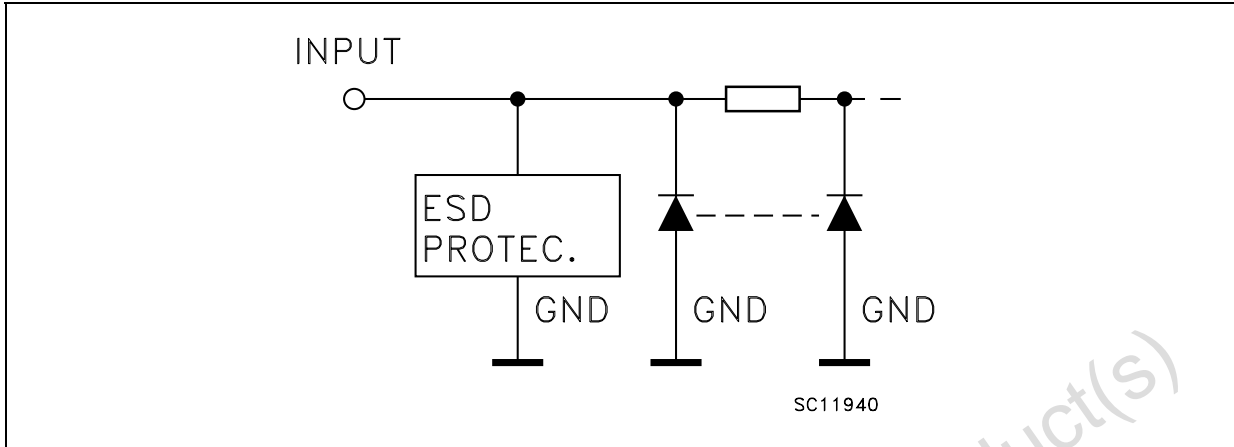

PIN DESCRIPTION

| PIN No                         | SYMBOL          | NAME AND FUNCTION                        |
|--------------------------------|-----------------|--|
| 1                              | 1OE             | 3 State Output Enable Input (Active LOW) |
| 2, 3, 5, 6, 8, 9, 11, 12       | 1Q0 to 1Q7      | 3-State Outputs                          |
| 13, 14, 16, 17, 19, 20, 22, 23 | 2Q0 to 2Q7      | 3-State Outputs                          |
| 24                             | 2OE             | 3 State Output Enable Input (Active LOW) |
| 25                             | 2LE             | Latch Enable Input*                      |
| 36, 35, 33, 32, 30, 29, 27, 26 | 2D0 to 2D7      | Data Inputs                              |
| 47, 46, 44, 43, 41, 40, 38, 37 | 1D0 to 1D7      | Data Inputs                              |
| 48                             | 1LE             | Latch Enable Input                       |
| 4, 10, 15, 21, 28, 34, 39, 45  | GND             | Ground (0V)                              |
| 7, 18, 31, 42                  | V <sub>CC</sub> | Positive Supply Voltage                  |

IEC LOGIC SYMBOLS

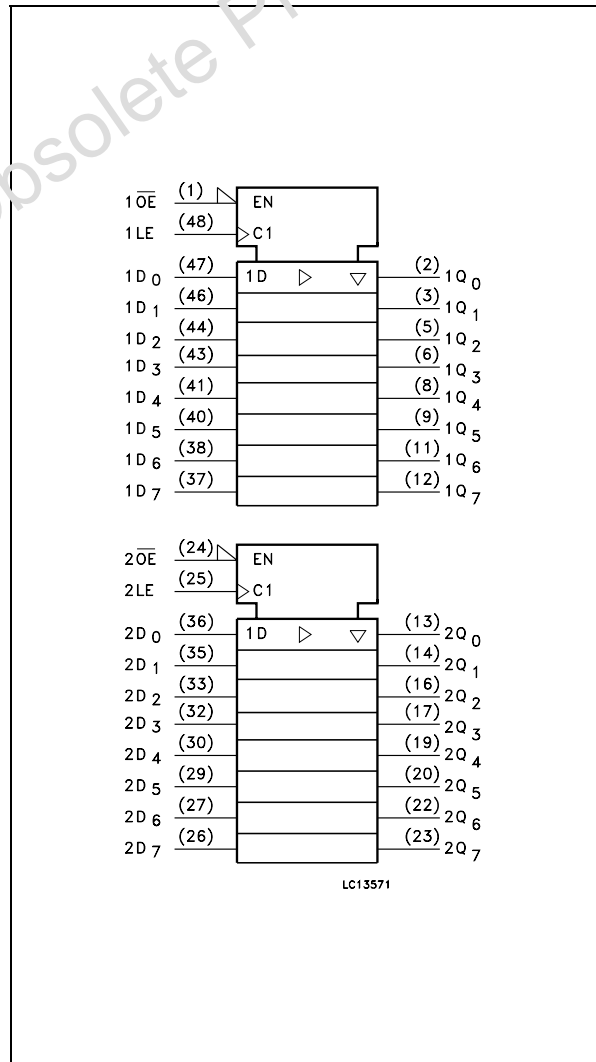

TRUTH TABLE

| INPUTS |    |   | OUTPUT      |
|--------|----|---|-------------|
| OE     | LE | D | Q           |
| H      | X  | X | Z           |
| L      | L  | X | NO CHANGE * |
| L      | H  | L | L           |
| L      | H  | H | H           |

X : Don't Care  
 Z : High Impedance  
 \* : Q outputs are latched at the time when the LE input is taken low logic level.

## LOGIC DIAGRAM

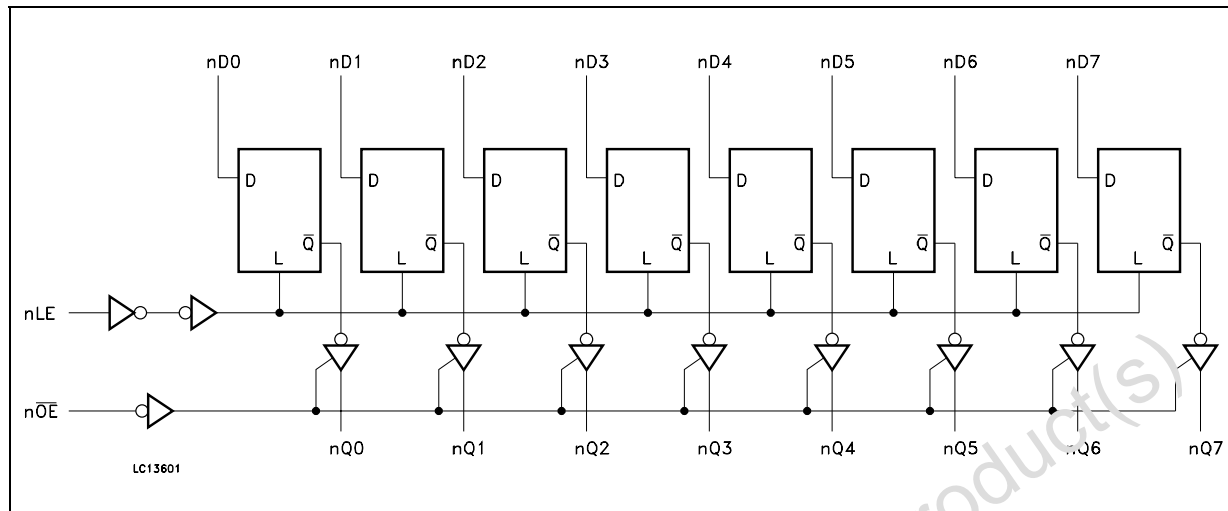

This logic diagram has not to be used to estimate propagation delays

## ABSOLUTE MAXIMUM RATINGS

| Symbol                | Parameter                     | Value                  | Unit        |
|-----------------------|-------------------------------|------------------------|-------------|
| $V_{CC}$              | Supply Voltage                | -0.5 to +7.0           | V           |
| $V_I$                 | DC Input Voltage              | -0.5 to +7.0           | V           |
| $V_O$                 | DC Output Voltage             | -0.5 to $V_{CC} + 0.5$ | V           |
| $I_{IK}$              | DC Input Diode Current        | - 20                   | mA          |
| $I_{OK}$              | DC Output Diode Current       | $\pm 20$               | mA          |
| $I_O$                 | DC Output Current             | $\pm 25$               | mA          |
| $I_{CC}$ or $I_{GND}$ | DC $V_{CC}$ or Ground Current | $\pm 50$               | mA          |
| $T_{stg}$             | Storage Temperature           | -65 to +150            | $^{\circ}C$ |
| $T_L$                 | Lead Temperature (10 sec)     | 300                    | $^{\circ}C$ |

Absolute Maximum Ratings are those values beyond which damage to the device may occur. Functional operation under these conditions is not implied

## RECOMMENDED OPERATING CONDITIONS

| Symbol   | Parameter   | Value         | Unit        |
|----------|---|---------------|-------------|
| $V_{CC}$ | Supply Voltage (note 1)                             | 2 to 3.6      | V           |
| $V_I$    | Input Voltage                                       | 0 to 5.5      | V           |
| $V_O$    | Output Voltage                                      | 0 to $V_{CC}$ | V           |
| $T_{op}$ | Operating Temperature                               | -55 to 125    | $^{\circ}C$ |
| dt/dv    | Input Rise and Fall Time (note 2) ( $V_{CC} = 3V$ ) | 0 to 100      | ns/V        |

1) Truth Table guaranteed: 1.2V to 3.6V

2)  $V_{IN}$  from 0.8V to 2.0V

## DC SPECIFICATIONS

| Symbol          | Parameter                             | Test Condition         |  | Value                 |      |       |             |       |              | Unit  |      |
|-----------------|---------------------------------------|------------------------|--|-----------------------|------|-------|-------------|-------|--------------|-------|------|
|                 |                                       | V <sub>CC</sub><br>(V) |  | T <sub>A</sub> = 25°C |      |       | -40 to 85°C |       | -55 to 125°C |       |      |
|                 |                                       |                        |  | Min.                  | Typ. | Max.  | Min.        | Max.  | Min.         |       | Max. |
| V <sub>IH</sub> | High Level Input Voltage              | 2.0                    |  | 1.5                   |      |       | 1.5         |       | 1.5          |       | V    |
|                 |                                       | 3.0                    |  | 2.0                   |      |       | 2.0         |       | 2.0          |       |      |
|                 |                                       | 3.6                    |  | 2.4                   |      |       | 2.4         |       | 2.4          |       |      |
| V <sub>IL</sub> | Low Level Input Voltage               | 2.0                    |  |                       |      | 0.5   |             | 0.5   |              | 0.5   | V    |
|                 |                                       | 3.0                    |  |                       |      | 0.8   |             | 0.8   |              | 0.8   |      |
|                 |                                       | 3.6                    |  |                       |      | 0.8   |             | 0.8   |              | 0.8   |      |
| V <sub>OH</sub> | High Level Output Voltage             | 2.0                    | I <sub>O</sub> =-50 μA   | 1.9                   | 2.0  |       | 1.9         |       | 1.9          |       | V    |
|                 |                                       | 3.0                    | I <sub>O</sub> =-50 μA   | 2.9                   | 3.0  |       | 2.9         |       | 2.9          |       |      |
|                 |                                       | 3.0                    | I <sub>O</sub> =-4 mA  | 2.58                  |      |       | 2.48        |       | 2.4          |       |      |
| V <sub>OL</sub> | Low Level Output Voltage              | 2.0                    | I <sub>O</sub> =50 μA  |                       | 0.0  | 0.1   |             | 0.1   |              | 0.1   | V    |
|                 |                                       | 3.0                    | I <sub>O</sub> =50 μA  |                       | 0.0  | 0.1   |             | 0.1   |              | 0.1   |      |
|                 |                                       | 3.0                    | I <sub>O</sub> =4 mA   |                       |      | 0.36  |             | 0.44  |              | 0.55  |      |
| I <sub>OZ</sub> | High Impedance Output Leakage Current | 3.6                    | V <sub>I</sub> = V <sub>IH</sub> or V <sub>IL</sub><br>V <sub>O</sub> = V <sub>CC</sub> or GND |                       |      | ± 25  |             | ± 2.5 |              | ± 2.5 | μA   |
| I <sub>I</sub>  | Input Leakage Current                 | 3.6                    | V <sub>I</sub> = 5V or GND   |                       |      | ± 0.1 |             | ± 1   |              | ± 1   | μA   |
| I <sub>CC</sub> | Quiescent Supply Current              | 3.6                    | V <sub>I</sub> = V <sub>CC</sub> or GND  |                       |      | 4     |             | 40    |              | 40    | μA   |

## DYNAMIC SWITCHING CHARACTERISTICS

| Symbol           | Parameter                                    | Test Condition         |                        | Value                 |      |      |             |      |              | Unit |      |
|------------------|--|------------------------|------------------------|-----------------------|------|------|-------------|------|--------------|------|------|
|                  |  | V <sub>CC</sub><br>(V) |                        | T <sub>A</sub> = 25°C |      |      | -40 to 85°C |      | -55 to 125°C |      |      |
|                  |  |                        |                        | Min.                  | Typ. | Max. | Min.        | Max. | Min.         |      | Max. |
| V <sub>OLP</sub> | Dynamic Low Voltage Quiet Output (note 1, 2) | 3.3                    | C <sub>L</sub> = 50 pF |                       | 0.3  | 0.8  |             |      |              |      | V    |
| V <sub>OLV</sub> |  |                        |                        | -0.8                  | -0.3 |      |             |      |              |      |      |
| V <sub>IHD</sub> | Dynamic High Voltage Input (note 1, 3)       | 3.3                    |                        | 2.0                   |      |      |             |      |              |      |      |
| V <sub>ILD</sub> | Dynamic Low Voltage Input (note 1, 3)        | 3.3                    |                        |                       |      | 0.8  |             |      |              |      |      |

1) Worst case package.

2) Max number of outputs defined as (n). Data inputs are driven 0V to 3.3V, (n-1) outputs switching and one output at GND.

3) Max number of data inputs (n) switching. (n-1) switching 0V to 3.3V. Inputs under test switching: 3.3V to threshold (V<sub>ILD</sub>), 0V to threshold (V<sub>IHD</sub>), f=1MHz.

AC ELECTRICAL CHARACTERISTICS (Input  $t_r = t_f = 3\text{ns}$ )

| Symbol                   | Parameter                                   | Test Condition     |               | Value                    |      |      |                             |      |                              |      |    | Unit |
|--------------------------|---|--------------------|---------------|--------------------------|------|------|-----------------------------|------|------------------------------|------|----|------|
|                          |   | $V_{CC}$<br>(V)    | $C_L$<br>(pF) | $T_A = 25^\circ\text{C}$ |      |      | $-40$ to $85^\circ\text{C}$ |      | $-55$ to $125^\circ\text{C}$ |      |    |      |
|                          |   |                    |               | Min.                     | Typ. | Max. | Min.                        | Max. | Min.                         | Max. |    |      |
| $t_{PLH}$<br>$t_{PHL}$   | Propagation Delay Time<br>LE to Qn          | 2.7                | 15            |                          | 7    | 14   | 1                           | 16   | 1                            | 16   | ns |      |
|                          |   | 2.7                | 50            |                          | 9    | 15.5 | 1                           | 17   | 1                            | 17   |    |      |
|                          |   | 3.3 <sup>(*)</sup> | 15            |                          | 5.5  | 13   | 1                           | 15   | 1                            | 15   |    |      |
|                          |   | 3.3 <sup>(*)</sup> | 50            |                          | 7    | 14.5 | 1                           | 16.5 | 1                            | 16.5 |    |      |
| $t_{PLH}$<br>$t_{PHL}$   | Propagation Delay Time<br>Dn to Qn          | 2.7                | 15            |                          | 8    | 14   | 1                           | 16   | 1                            | 16   | ns |      |
|                          |   | 2.7                | 50            |                          | 9.5  | 15   | 1                           | 17   | 1                            | 17   |    |      |
|                          |   | 3.3 <sup>(*)</sup> | 15            |                          | 5.4  | 13   | 1                           | 15   | 1                            | 15   |    |      |
|                          |   | 3.3 <sup>(*)</sup> | 50            |                          | 7.5  | 14   | 1                           | 16   | 1                            | 16.5 |    |      |
| $t_{PZL}$<br>$t_{PZH}$   | Output Enable Time                          | 2.7                | 15            |                          | 7    | 14.9 | 1                           | 16   | 1                            | 16   | ns |      |
|                          |   | 2.7                | 50            |                          | 9.5  | 16   | 1                           | 17   | 1                            | 17   |    |      |
|                          |   | 3.3 <sup>(*)</sup> | 15            |                          | 5.2  | 13   | 1                           | 15   | 1                            | 15   |    |      |
|                          |   | 3.3 <sup>(*)</sup> | 50            |                          | 7.6  | 14.9 | 1                           | 16   | 1                            | 16   |    |      |
| $t_{PLZ}$<br>$t_{PHZ}$   | Output Disable Time                         | 2.7                | 50            |                          | 7    | 17   | 1                           | 18   | 1                            | 18   | ns |      |
|                          |   | 3.3 <sup>(*)</sup> | 50            |                          | 7.7  | 15.5 | 1                           | 17   | 1                            | 17   |    |      |
| $t_W$                    | LE pulse Width,<br>HIGH                     | 2.7                | 50            |                          | 5    |      |                             | 6    |                              | 6    | ns |      |
|                          |   | 3.3 <sup>(*)</sup> | 50            |                          | 5    |      |                             | 5    |                              | 5    |    |      |
| $t_S$                    | Setup Time Dn to<br>LE HIGH or LOW          | 2.7                | 50            |                          | 4.5  |      |                             | 4.5  |                              | 4.5  | ns |      |
|                          |   | 3.3 <sup>(*)</sup> | 50            |                          | 4    |      |                             | 4    |                              | 4    |    |      |
| $t_H$                    | Hold Time Dn to LE<br>HIGH or LOW           | 2.7                | 50            |                          | 1.5  |      |                             | 1.5  |                              | 1.5  | ns |      |
|                          |   | 3.3 <sup>(*)</sup> | 50            |                          | 1    |      |                             | 1    |                              | 1    |    |      |
| $t_{OSLH}$<br>$t_{OSHL}$ | Output to Output<br>Skew Time (note<br>1,2) | 2.7                | 50            |                          | 0.5  | 1.0  |                             | 1.5  |                              | 1.5  | ns |      |
|                          |   | 3.3 <sup>(*)</sup> | 50            |                          | 0.5  | 1.0  |                             | 1.5  |                              | 1.5  |    |      |

1) Skew is defined as the absolute value of the difference between the actual propagation delay for any two outputs of the same device switching in the same direction, either HIGH or LOW

2) Parameter guaranteed by design

(\*) Voltage range is  $3.3\text{V} \pm 0.3\text{V}$

## CAPACITIVE CHARACTERISTICS

| Symbol    | Parameter                                 | Test Condition  |                         | Value                    |      |      |                             |      |                              |      |    | Unit |
|-----------|---|-----------------|-------------------------|--------------------------|------|------|-----------------------------|------|------------------------------|------|----|------|
|           |   | $V_{CC}$<br>(V) |                         | $T_A = 25^\circ\text{C}$ |      |      | $-40$ to $85^\circ\text{C}$ |      | $-55$ to $125^\circ\text{C}$ |      |    |      |
|           |   |                 |                         | Min.                     | Typ. | Max. | Min.                        | Max. | Min.                         | Max. |    |      |
| $C_{IN}$  | Input Capacitance                         |                 |                         |                          | 2.5  | 10   |                             | 10   |                              | 10   | pF |      |
| $C_{OUT}$ | Output Capacitance                        |                 |                         |                          | 4    |      |                             |      |                              |      | pF |      |
| $C_{PD}$  | Power Dissipation Capacitance<br>(note 1) | 3.0             | $f_{IN} = 10\text{MHz}$ |                          | 17   |      |                             |      |                              |      | pF |      |

1)  $C_{PD}$  is defined as the value of the IC's internal equivalent capacitance which is calculated from the operating current consumption without load. (Refer to Test Circuit). Average operating current can be obtained by the following equation.  $I_{CC(opr)} = C_{PD} \times V_{CC} \times f_{IN} + I_{CC}/n$  (per circuit)

TEST CIRCUIT

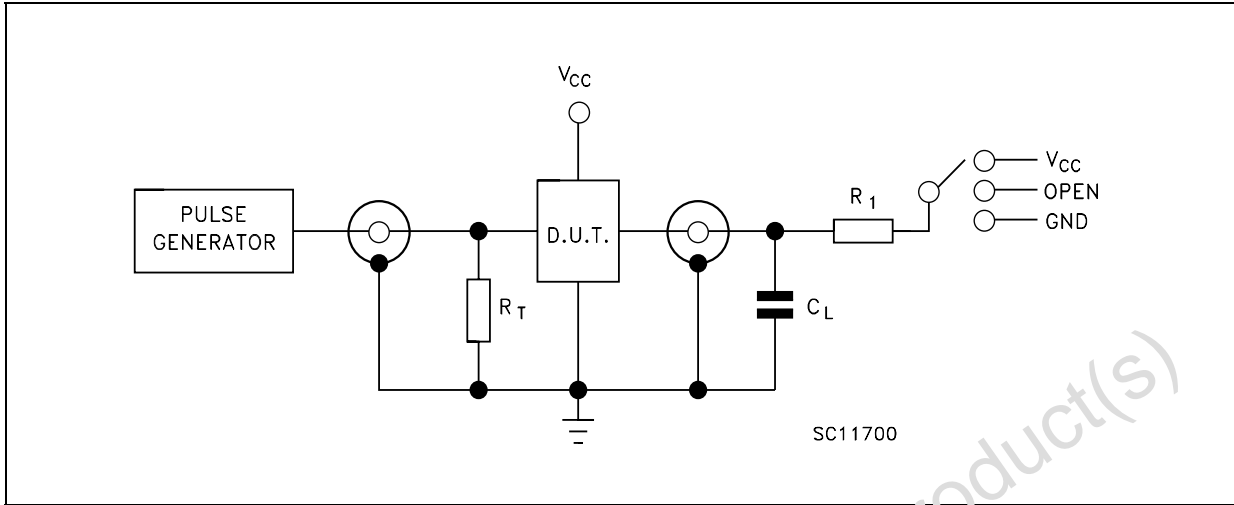

| TEST                  | SWITCH   |
|-----------------------|----------|
| $t_{PLH}$ , $t_{PHL}$ | Open     |
| $t_{PZL}$ , $t_{PLZ}$ | $V_{CC}$ |
| $t_{PZH}$ , $t_{PHZ}$ | GND      |

$C_L = 15/50$  pF or equivalent (includes jig and probe capacitance)  
 $R_L = R_1 = 1K\Omega$  or equivalent  
 $R_T = Z_{OUT}$  of pulse generator (typically  $50\Omega$ )

**WAVEFORM 1 : LE TO Qn PROPAGATION DELAYS, LE MINIMUM PULSE WIDTH, Dn TO LE SETUP AND HOLD TIMES** (f=1MHz; 50% duty cycle)

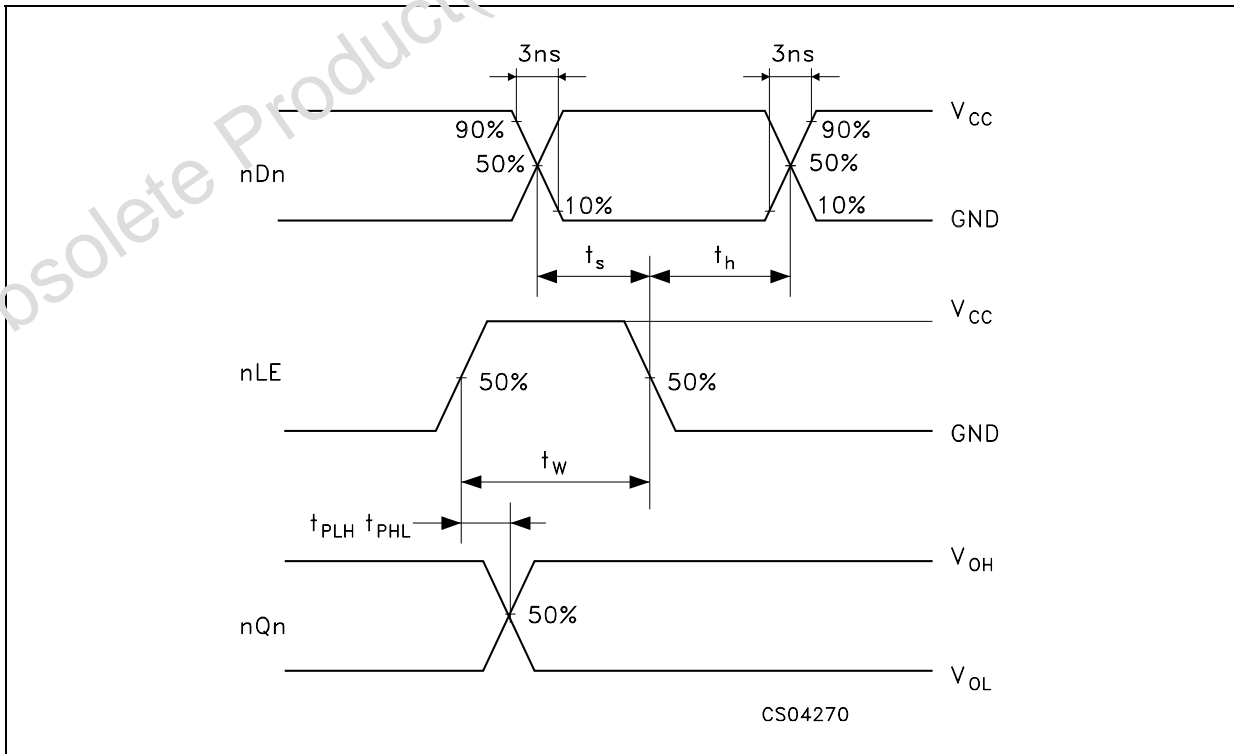

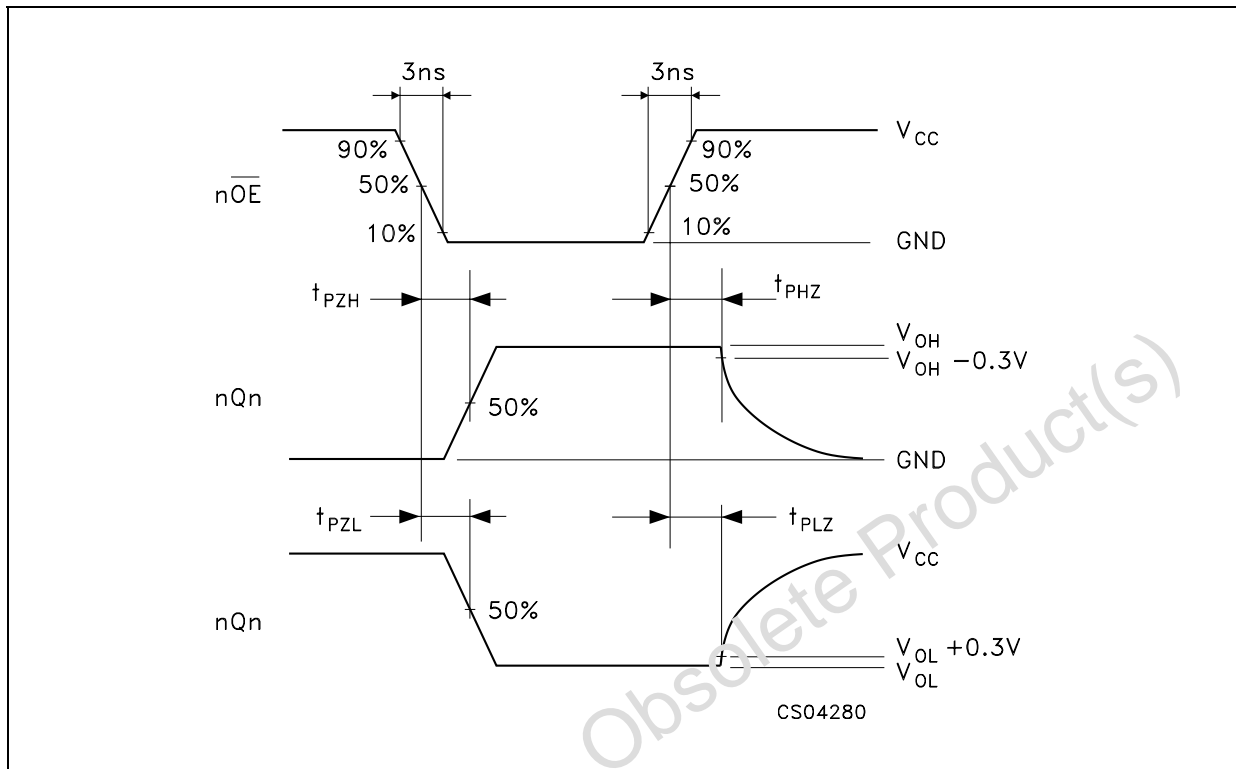
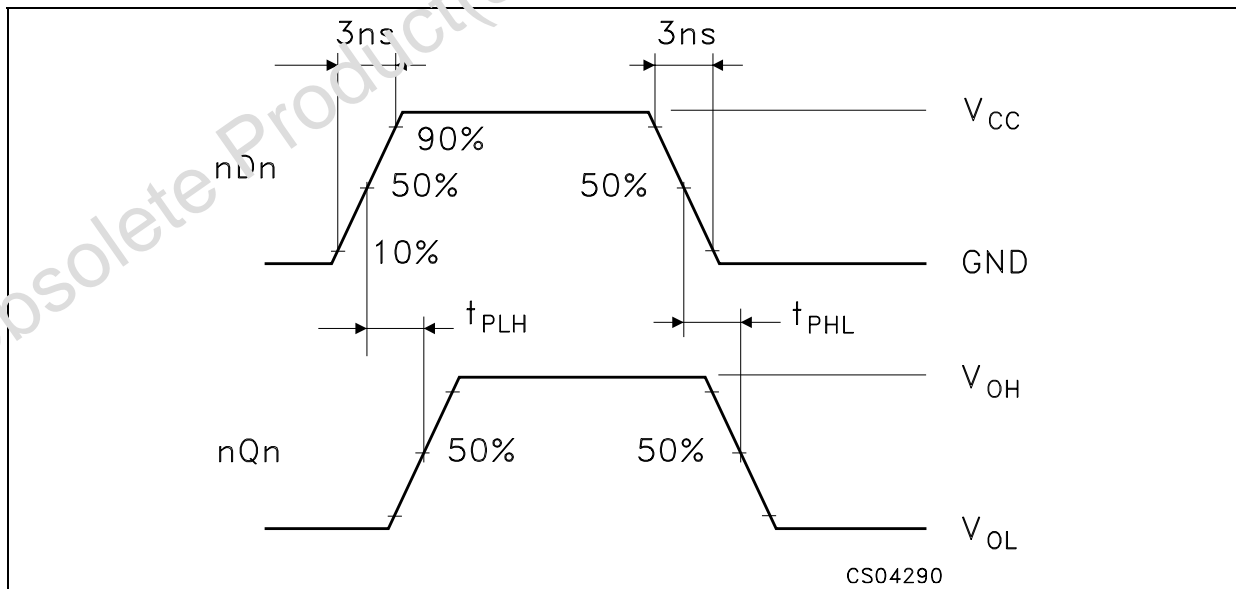
**WAVEFORM 2 : OUTPUT ENABLE AND DISABLE TIME (f=1MHz; 50% duty cycle)****WAVEFORM 3 : PROPAGATION DELAY TIME (f=1MHz; 50% duty cycle)**

## TSSOP48 MECHANICAL DATA

| DIM. | mm.  |         |      | inch   |            |        |
|------|------|---------|------|--------|------------|--------|
|      | MIN. | TYP     | MAX. | MIN.   | TYP.       | MAX.   |
| A    |      |         | 1.2  |        |            | 0.047  |
| A1   | 0.05 |         | 0.15 | 0.002  |            | 0.006  |
| A2   |      | 0.9     |      |        | 0.035      |        |
| b    | 0.17 |         | 0.27 | 0.0067 |            | 0.011  |
| c    | 0.09 |         | 0.20 | 0.0035 |            | 0.0079 |
| D    | 12.4 |         | 12.6 | 0.488  |            | 0.496  |
| E    |      | 8.1 BSC |      |        | 0.318 BSC  |        |
| E1   | 6.0  |         | 6.2  | 0.236  |            | 0.244  |
| e    |      | 0.5 BSC |      |        | 0.0197 BSC |        |
| K    | 0°   |         | 8°   | 0°     |            | 8°     |
| L    | 0.50 |         | 0.75 | 0.020  |            | 0.030  |

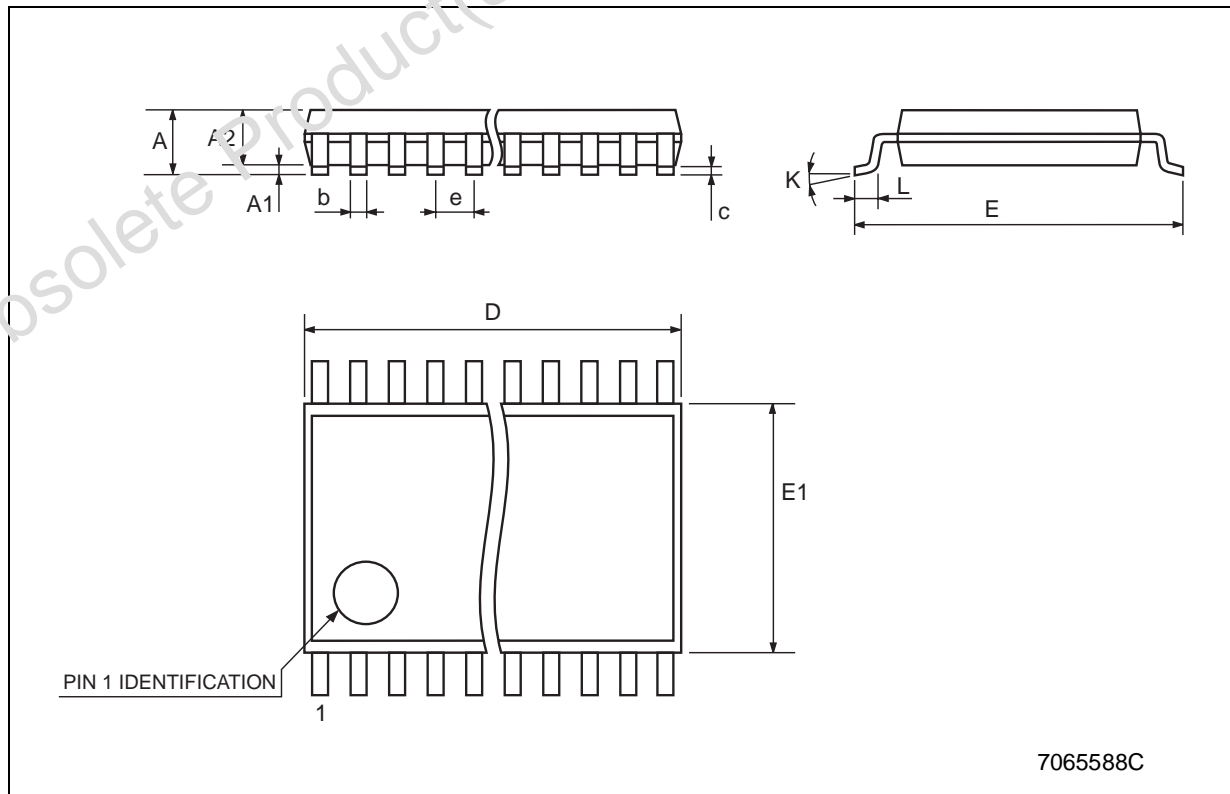



### Tape & Reel TSSOP48 MECHANICAL DATA

| DIM. | mm.  |     |      | inch  |      |        |
|------|------|-----|------|-------|------|--------|
|      | MIN. | TYP | MAX. | MIN.  | TYP. | MAX.   |
| A    |      |     | 330  |       |      | 12.992 |
| C    | 12.8 |     | 13.2 | 0.504 |      | 0.519  |
| D    | 20.2 |     |      | 0.795 |      |        |
| N    | 60   |     |      | 2.362 |      |        |
| T    |      |     | 30.4 |       |      | 1.197  |
| Ao   | 8.7  |     | 8.9  | 0.343 |      | 0.350  |
| Bo   | 13.1 |     | 13.3 | 0.516 |      | 0.524  |
| Ko   | 1.5  |     | 1.7  | 0.059 |      | 0.067  |
| Po   | 3.9  |     | 4.1  | 0.153 |      | 0.161  |
| P    | 11.9 |     | 12.1 | 0.468 |      | 0.476  |

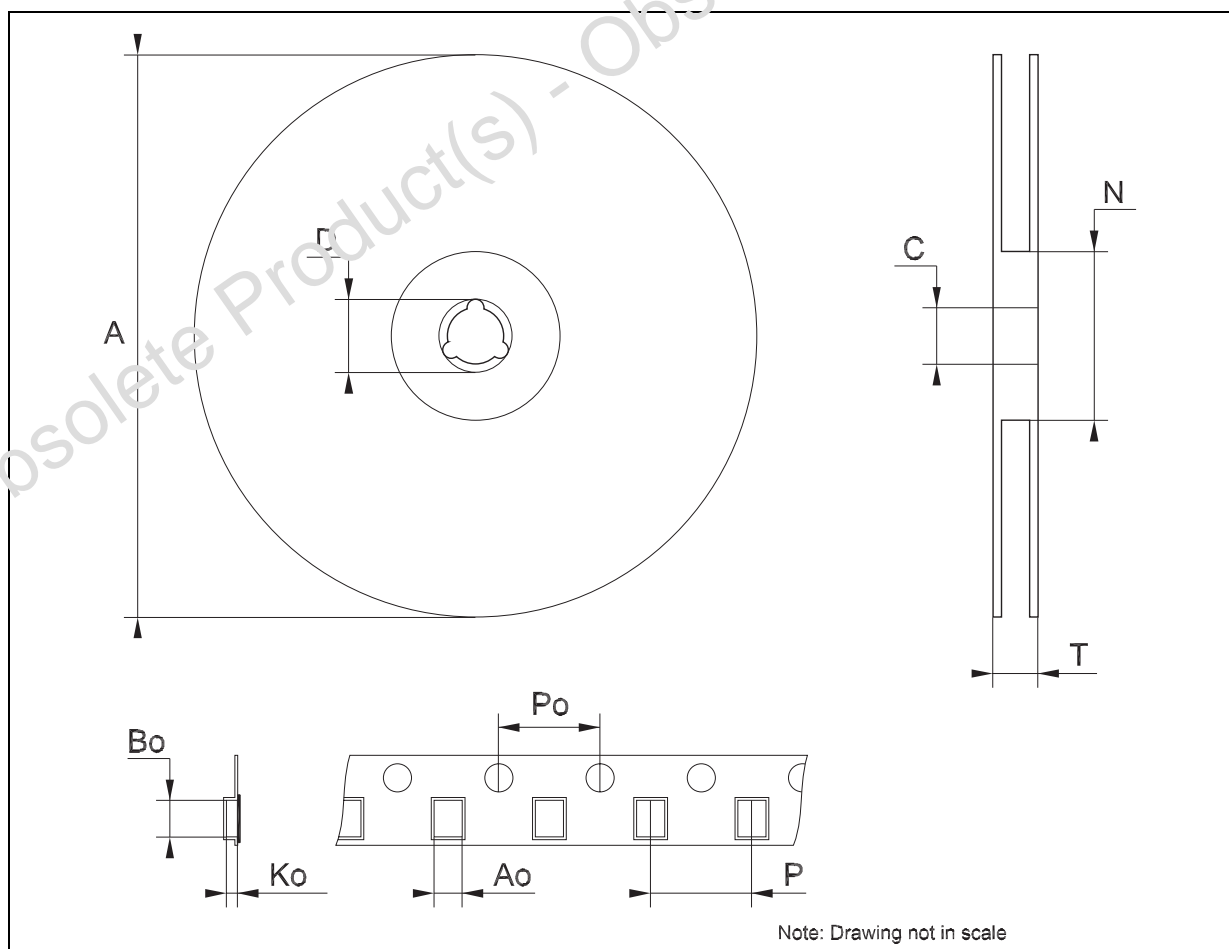

Obsolete Product(s) - Obsolete Product(s)

Information furnished is believed to be accurate and reliable. However, STMicroelectronics assumes no responsibility for the consequences of use of such information nor for any infringement of patents or other rights of third parties which may result from its use. No license is granted by implication or otherwise under any patent or patent rights of STMicroelectronics. Specifications mentioned in this publication are subject to change without notice. This publication supersedes and replaces all information previously supplied. STMicroelectronics products are not authorized for use as critical components in life support devices or systems without express written approval of STMicroelectronics.

© The ST logo is a registered trademark of STMicroelectronics

© 2003 STMicroelectronics - Printed in Italy - All Rights Reserved  
STMicroelectronics GROUP OF COMPANIES

Australia - Brazil - Canada - China - Finland - France - Germany - Hong Kong - India - Israel - Italy - Japan - Malaysia - Malta - Morocco  
Singapore - Spain - Sweden - Switzerland - United Kingdom - United States.

© <http://www.st.com>

## X-ON Electronics

Largest Supplier of Electrical and Electronic Components

*Click to view similar products for [Latches](#) category:*

*Click to view products by [STMicroelectronics](#) manufacturer:*

Other Similar products are found below :

[M38510/75403BSA](#) [634674X](#) [634752C](#) [ML4875CS-5](#) [54FCT573ATDB](#) [401639B](#) [027063C](#) [029314R](#) [54FCT573CTLB](#) [NLV14043BDR2G](#)  
[716165RB](#) [74F373DW](#) [74LVC373ADTR2G](#) [74LVC573ADTR2G](#) [NL17SG373DFT2G](#) [NLV14044BDG](#) [5962-8863901RA](#) [5962-88639012A](#)  
[2.PM30.006-30](#) [MIC59P50YV](#) [NLV14042BDR2G](#) [MIC58P01YWM-TR](#) [4.401.001](#) [NLV14044BDR2G](#) [2.L18.001-21](#) [2.PM18.002-18](#)  
[2.PM18.006-18](#) [2.T18.001-21](#) [2.T18.002-18](#) [2.T18.006-18](#) [CQ/A-M22X1,5-45-28](#) [CQ/A-M22X1,5-45-32](#) [CY74FCT2373CTSOC](#) [421283](#)  
[MM74HC373WM](#) [MM74HC573MTCX](#) [MM74HC573WM](#) [74LCX373MTC](#) [74LVT16373MTDX](#) [74VHC373MX](#) [KLD5.001-02](#) [KLT9.001-](#)  
[02](#) [74AHCT573D.112](#) [74FCT16373CTPVG8](#) [74FCT573ATQG](#) [74LCX16373MTDX](#) [CQ/A-M22X1,5-45-16](#) [CQ/A-M22X1,5-45-18](#) [CQ/A-](#)  
[M22X1,5-45-20](#) [CQ/A-M22X1,5-45-24](#)