



L6925D

HIGH EFFICIENCY MONOLITHIC SYNCHRONOUS STEP DOWN REGULATOR

1 FEATURES

- 2.7V TO 5.5V BATTERY INPUT RANGE
- HIGH EFFICIENCY: UP TO 95%
- INTERNAL SYNCHRONOUS SWITCH
- NO EXTERNAL SCHOTTKY REQUIRED
- EXTREMELY LOW QUIESCENT CURRENT
- 800mA MAX OUTPUT CURRENT
- ADJUSTABLE OUTPUT VOLTAGE FROM 0.6V
- LOW DROP-OUT OPERATION: UP TO 100% DUTY CYCLE
- SELECTABLE LOW NOISE/LOW CONSUMPTION MODE AT LIGHT LOAD
- LOW BATTERY INPUT
- LOW BATTERY OUTPUT
- $\pm 1\%$ OUTPUT VOLTAGE ACCURACY
- CURRENT-MODE CONTROL
- 600kHz SWITCHING FREQUENCY
- EXTERNALLY SYNCHRONIZABLE FROM 500kHz TO 1.4MHz
- OVP
- SHORT CIRCUIT PROTECTION

1.1 APPLICATIONS

- BATTERY-POWERED EQUIPMENTS
- PORTABLE INSTRUMENTS
- CELLULAR PHONES
- PDAs AND HAND HELD TERMINALS
- DSC
- GPS

Figure 1. Package

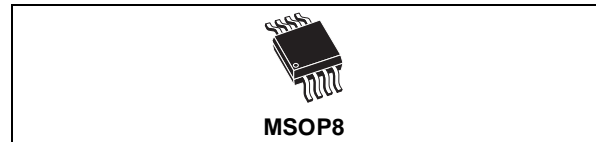

Table 1. Order Codes

Part Number	Package
L6925D	MSOP8 (Tube)
L6925D013TR	Tape & Reel

2 DESCRIPTION

The device is dc-dc monolithic regulator specifically designed to provide extremely high efficiency.

The device has on UVLO set at 2.7V cause it is particularly thought for single Li-ion cell applications. Output voltage can be selected by an external divider down to 0.6V. Duty Cycle can saturate to 100% allowing low drop-out operation.

The device is based on a 600kHz fixed-frequency, current mode-architecture. Low Consumption Mode operation can be selected at light load conditions, allowing switching losses to be reduced. L6925D is externally synchronizable with a clock which makes it useful in noise-sensitive applications.

LBI pin can be used to have a $\overline{\text{LBO}}$ signal when the Battery voltage is lower than a preset value. Other features like, Overvoltage protection, Shortcircuit protection and Thermal Shutdown (150°C) are also present.

Figure 2. Application Test Circuit

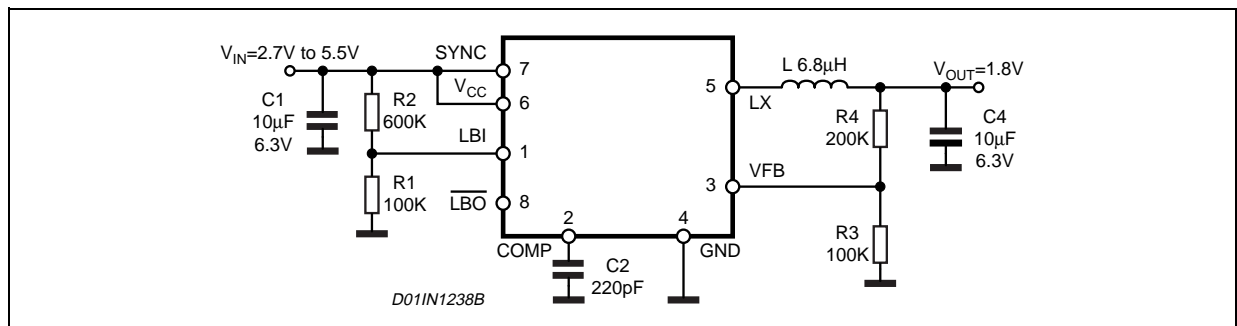

Table 2. Absolute Maximum Ratings

Symbol	Parameter	Value	Unit
V ₆	Input voltage	-0.3 to 6	V
V ₅	Output switching voltage	-1 to V _{CC}	V
V ₁ , V ₈	Low Battery Input, Low Battery Output	-0.3 to V _{CC}	V
V ₃	Feedback voltage	-0.3 to V _{CC}	V
V ₂	Error Amplifier Output Voltage	-0.3 to V _{CC}	V
V ₇	Synchronization / Mode Selector	-0.3 to V _{CC}	V
P _{tot}	Power dissipation at Tamb=70°C	0.45	W
T _j	Junction operating temperature range	-40 to 150	°C
T _{stg}	Storage temperature range	-65 to 150	°C
LX Pin	Maximum Withstanding Voltage Range Test Condition: CDF-AEC-Q100-002- "Human Body Model" Acceptance Criteria: "Normal Performance"	±1000	V
Other pins		±2000	V

Figure 3. Pin Connection

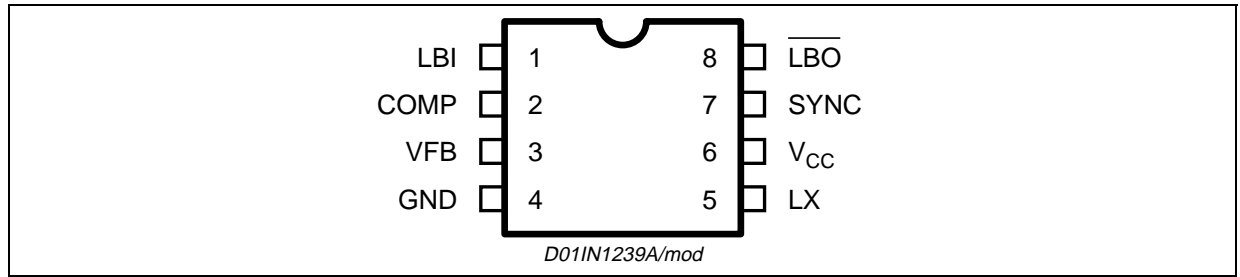

Table 3. Thermal Data

Symbol	Parameter	Value	Unit
R _{th j-amb}	Thermal Resistance Junction to Ambient	180	°C/W

Table 4. Pin Functions

N	Name	Description
1	LBI	Battery low voltage detector input. The internal threshold is set to 0.6V. The external threshold can be adjusted by using an external resistor divider.
2	COMP	Error amplifier output. Compensate it with a 220pF capacitor
3	VFB	Error amplifier input. The output voltage can be adjusted by using an external resistor divider connected to this pin (V _{FB} = 0.6V).
4	GND	Ground.
5	LX	Switch node connection to the inductor.
6	VCC	Input voltage.
7	SYNC	This pin allows to select Low Noise/ Low Consumption Mode or to synchronize the device.
8	$\overline{\text{LBO}}$	Battery low voltage detector output. If the voltage at the LBI pin drops below the internal threshold, $\overline{\text{LBO}}$ goes low. The $\overline{\text{LBO}}$ is an open drain output. A pull_up resistor should be connected between the pin and the output voltage

Table 5. ELECTRICAL CHARACTERISTICS ($T_J = 25^\circ\text{C}$, $V_{CC} = 3.6\text{V}$ unless otherwise specified)

Symbol	Parameter	Test Condition	Min	Typ	Max	Unit
V_{CC}	Operating input voltage	After Turn On	2.7		5.5	V
$V_{CC\ ON}$	Turn On threshold			2.8		V
$V_{CC\ OFF}$	Turn Off threshold			2.65		V
$V_{CC\ hys}$	Hysteresis			150		mV
R_p	High side R_{on}	$V_{CC} = 3.6\text{V}$, $I_{LX} = 100\text{mA}$		240		$\text{m}\Omega$
R_n	Low side R_{on}	$V_{CC} = 3.6\text{V}$, $I_{LX} = 100\text{mA}$		215		$\text{m}\Omega$
I_{lim}	Peak current limit	$V_{CC} = 3.6\text{V}$		1.2		A
	Valley current limit	$V_{CC} = 3.6\text{V}$		1.4		A
V_{out}	Output voltage range		0.6		V_{CC}	V
f_{osc}	Oscillator frequency			600		KHz
f_{sync}	Sync mode clock (*)		500		1400	KHz
DC CHARACTERISTICS						
I_q	Quiescent current (low noise mode)	$V_{sync} = 0\text{V}$, no load, $V_{FB} > 0.6\text{V}$		230		μA
	Quiescent current (low consumption mode)	$V_{sync} = V_{CC}$, no load, $V_{FB} > 0.6\text{V}$		25		μA
I_{sh}	Shutdown current	$V_{CC} < 2.7\text{V}$, $V_{FB} > 0.6\text{V}$		0.2		μA
I_{LX}	LX leakage current (*)	$V_{CC} < 2.7\text{V}$, $V_{LX} = V_{CC}$		1		μA
		$V_{CC} < 2.7\text{V}$, $V_{LX} = 0\text{V}$		1		μA
ERROR AMPLIFIER CHARACTERISTICS						
V_{fb}	Voltage feedback		0.593	0.6	0.607	V
I_{fb}	Feedback input current (*)	$V_{FB} = 0.6\text{V}$		25		nA
SYNC/MODE FUNCTION						
V_{sync_H}	Sync mode threshold high				1.3	V
V_{sync_L}	Sync mode threshold low		0.5			V
LB SECTION						
V_{LBI}	LBI Threshold			0.6		V
$V_{\overline{LBO}}$	\overline{LBO} Logic Low	$I_{sink} = 1\text{mA}$, $V_{CC} = 3.6\text{V}$, $V_{LBI} < 0.6\text{V}$		0.2	0.4	V
$I_{LK-\overline{LBO}}$	\overline{LBO} Leakage Current (*)	$V_{\overline{LBO}} = 3.6\text{V}$, $V_{CC} = 3.6\text{V}$, $V_{LBI} > 0.6\text{V}$			50	nA
PROTECTIONS						
HOVP	Hard overvoltage threshold			10		%Vout

(*) Guaranteed by design

Figure 4. MSOP8 Mechanical Data & Package Dimensions

DIM.	mm			inch		
	MIN.	TYP.	MAX.	MIN.	TYP.	MAX.
A			1.10			0.043
A1	0.050		0.150	0.002		0.006
A2	0.750	0.850	0.950	0.03	0.033	0.037
b	0.250		0.400	0.010		0.016
c	0.130		0.230	0.005		0.009
D (1)	2.900	3.000	3.100	0.114	0.118	0.122
E	4.650	4.900	5.150	0.183	0.193	0.20
E1 (1)	2.900	3.000	3.100	0.114	0.118	0.122
e		0.650			0.026	
L	0.400	0.550	0.700	0.016	0.022	0.028
L1		0.950			0.037	
k	0° (min.) 6° (max.)					
aaa			0.100			0.004

Note: 1. D and F does not include mold flash or protrusions. Mold flash or protrusions shall not exceed 0.15mm (.006inch) per side.

OUTLINE AND MECHANICAL DATA

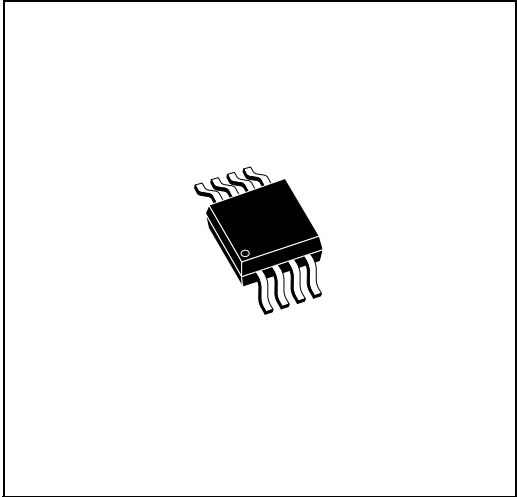

MSOP8 (Body 3mm)

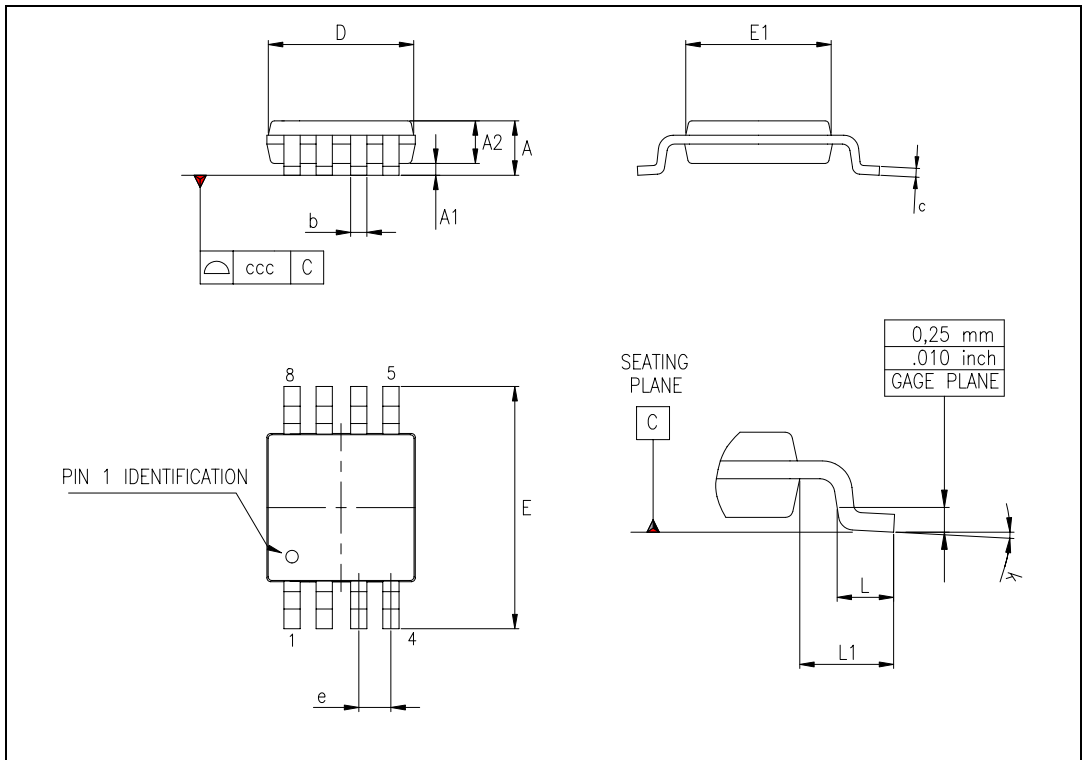

Table 6. Revision History

Date	Revision	Description of Changes
January 2004	2	First Issue in EDOCS DMS
September 2004	3	Changed Style-sheet and Table 2

Information furnished is believed to be accurate and reliable. However, STMicroelectronics assumes no responsibility for the consequences of use of such information nor for any infringement of patents or other rights of third parties which may result from its use. No license is granted by implication or otherwise under any patent or patent rights of STMicroelectronics. Specifications mentioned in this publication are subject to change without notice. This publication supersedes and replaces all information previously supplied. STMicroelectronics products are not authorized for use as critical components in life support devices or systems without express written approval of STMicroelectronics.

The ST logo is a registered trademark of STMicroelectronics.
All other names are the property of their respective owners

© 2004 STMicroelectronics - All rights reserved

STMicroelectronics group of companies

Australia - Belgium - Brazil - Canada - China - Czech Republic - Finland - France - Germany - Hong Kong - India - Israel - Italy - Japan -
Malaysia - Malta - Morocco - Singapore - Spain - Sweden - Switzerland - United Kingdom - United States of America

www.st.com

X-ON Electronics

Largest Supplier of Electrical and Electronic Components

Click to view similar products for [Voltage Regulators - Switching Regulators](#) category:

Click to view products by [STMicroelectronics](#) manufacturer:

Other Similar products are found below :

[LX7186A](#) [622616F](#) [632259F](#) [MP2148GQD-33-P](#) [MP2374DS-LF-Z](#) [EN6310QA](#) [L79M05TL-E](#) [FAN48610BUC45X](#) [R3](#) [430464BB](#)
[455605G](#) [MIC4930YFL-T5](#) [KE177614](#) [418569H](#) [455596X](#) [511087D](#) [030908C](#) [063375FB](#) [067501FB](#) [099508GB](#) [EP5358LUA](#)
[NCP81102MNTXG](#) [715715H](#) [FAN48611UC53X](#) [FAN53611AUC12X](#) [MAX809TTR](#) [MAX77596ETBC+T](#) [MAX77596ETBB+T](#)
[MAX16905AUE/V+](#) [NCP6332CMTAATBG](#) [LX7176A](#) [MP2162AGQH-Z](#) [MAX17544ATP+T](#) [MCP1623T-IMC](#) [MCP1642B-18IMC](#)
[MCP1642BT-30I/MS](#) [MCP1642D-50IMC](#) [MCP1642D-50IMS](#) [MCP1642D-ADJIMC](#) [MC34063LBBGEVB](#) [MCP1252T-33X50IMS](#)
[MCP1259-EMF](#) [MCP1602-250IMF](#) [MCP1640CT-IMC](#) [MCP1642B-30IMC](#) [MCP1642B-50IMC](#) [MCP1642B-50IMS](#) [MCP1642B-ADJIMC](#)
[MCP1642D-18IMC](#) [MCP1642D-30IMC](#)