

Automotive 6-line IPAD™ low capacitance EMI filter and ESD protection in micro QFN package

Datasheet - production data

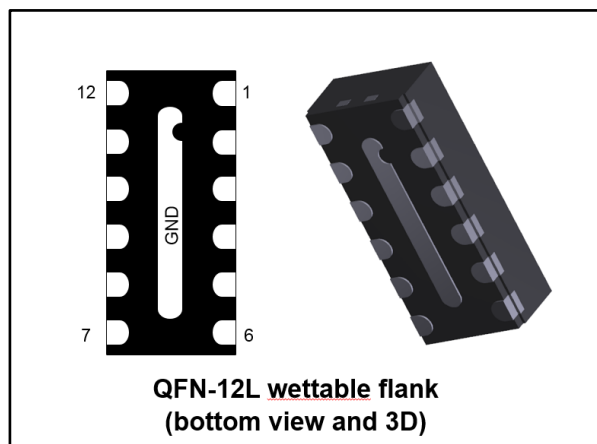

Features

- AEC-Q101 qualified
- EMI symmetrical (I/O) low-pass filter
- High efficiency in EMI filtering: -34 dB at frequencies from 900 MHz to 1.8 GHz
- Very low PCB space consumption: 3 mm x 1.35 mm
- Very thin package: 0.8 mm max
- High efficiency in ESD suppression on input pins (IEC 61000-4-2 level 4)
- High reliability offered by monolithic integration
- High reduction of parasitic elements through integration and wafer level packaging
- Lead-free package



Complies with the following standards

- IEC 61000-4-2 level 4 input and output pins
 - 15 kV (air discharge)
 - 15 kV (contact discharge)
- ISO10605 input and output pins:
 - 11kV (air discharge)
 - 11kV (contact discharge)
- MIL STD 883G - method 3015-7 Class 3B (all pins)

Applications

Where EMI filtering in ESD sensitive equipment is required:

- LCD and camera for cars
- DSP inputs
- V2V, V2I communication systems
- Digital tuner inputs

Description

This is a highly integrated 6-line device designed to suppress EMI/RFI noise in all systems exposed to electromagnetic interference.

This filter includes ESD protection circuitry, which prevents the application from damages when subjected to ESD surges up to 15 kV on the input pins.

Figure 1: Pin configuration (top view)

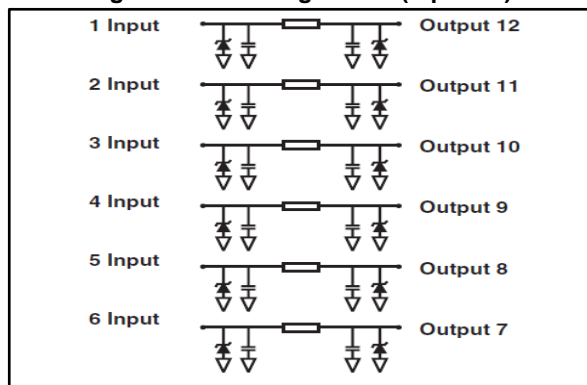
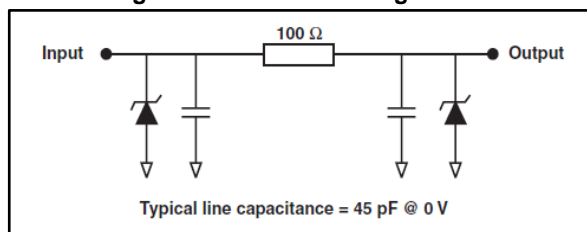

Figure 2: Basic cell configuration



1 Characteristics

Table 1: Absolute ratings (limiting values at $T_{amb} = 25\text{ }^{\circ}\text{C}$ unless otherwise specified)

Symbol	Parameter		Value	Unit
V_{pp}	Peak pulse voltage	ESD IEC 61000-4-2		
		Contact discharge	15	kV
		Air discharge	15	
		ISO 10605 (330 pF - 330 Ω)		
		Contact discharge	11	
Air discharge	11			
T_j	Operating junction temperature		150	$^{\circ}\text{C}$
T_{stg}	Storage temperature range		-55 to +150	$^{\circ}\text{C}$
T_{op}	Operating temperature range		-55 to +150	$^{\circ}\text{C}$

Figure 3: Electrical characteristics (definitions)

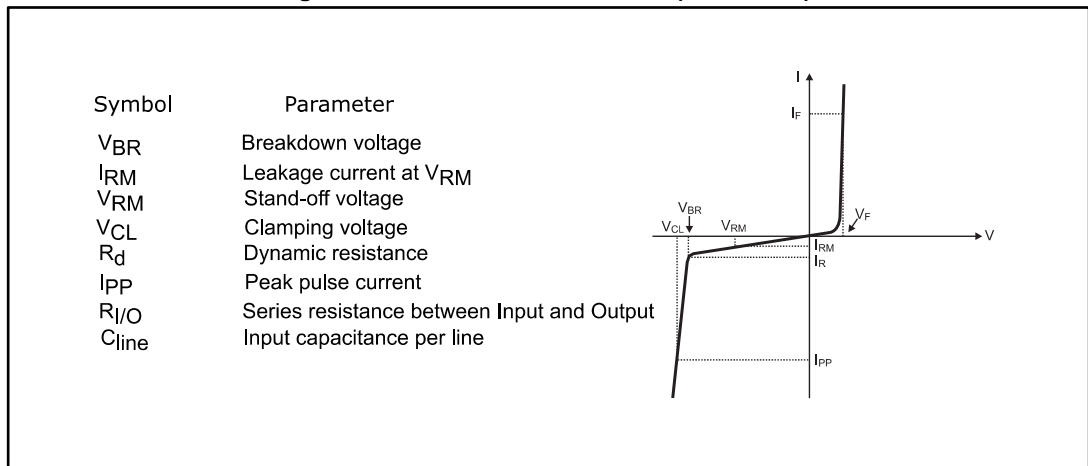
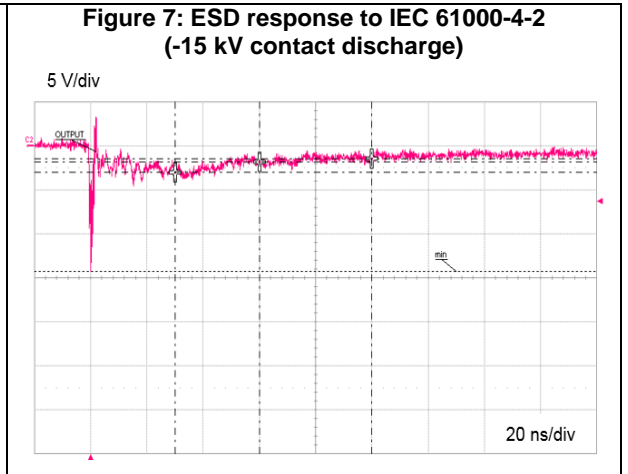
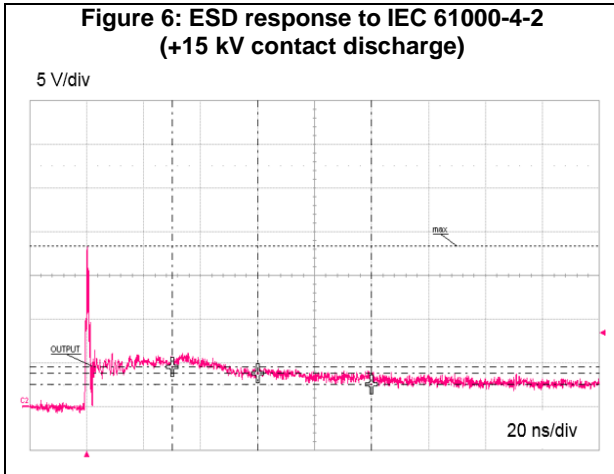
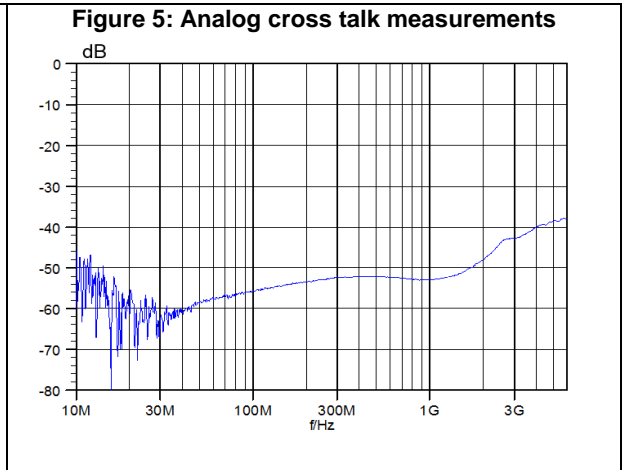
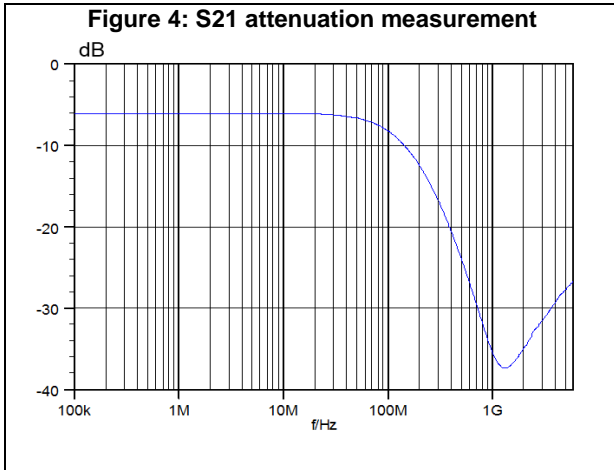

Table 2: Electrical characteristics ($T_{amb} = 25\text{ }^{\circ}\text{C}$)

Symbol	Test conditions	Min.	Typ.	Max.	Unit
V_{BR}	$I_R = 1\text{ mA}$	6	8	10	V
V_F	$I_F = 10\text{ mA}$	0.5	1.0	1.5	
I_{RM}	$V_{RM} = 3\text{ V per line}$			200	nA
$R_{I/O}$	Tolerance $\pm 10\%$	90	100	110	Ω
C_{line}	$V_{LINE} = 0\text{ V dc}$, $V_{osc} = 30\text{ mV}$, $f = 1\text{ MHz}$	38	45	52	pF

1.1 Characteristics (curves)



Pulse applied on input and measured on output. Behavior is symmetrical.

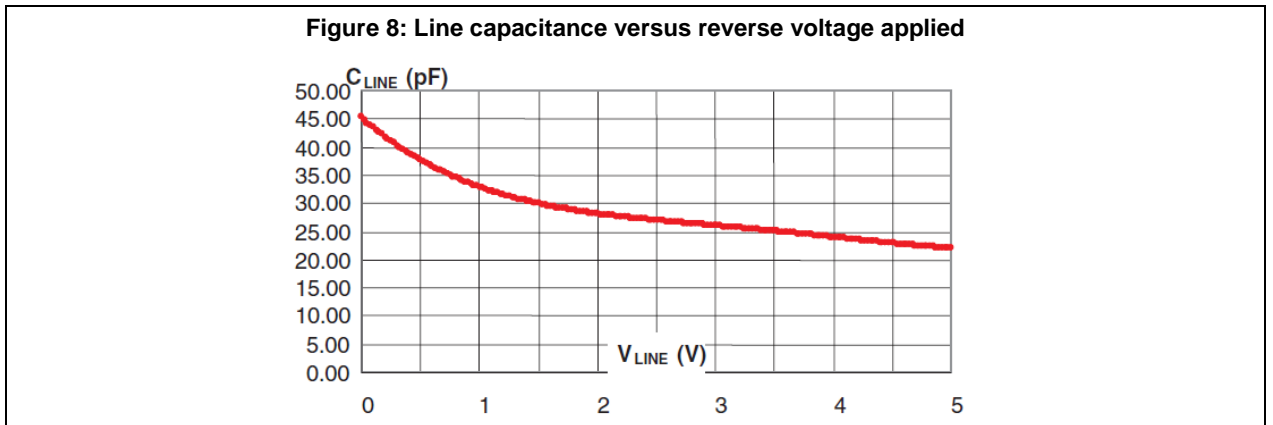

2 Package information

In order to meet environmental requirements, ST offers these devices in different grades of ECOPACK® packages, depending on their level of environmental compliance. ECOPACK® specifications, grade definitions and product status are available at: www.st.com. ECOPACK® is an ST trademark.

2.1 QFN-12L package information

Figure 9: QFN-12L package outline

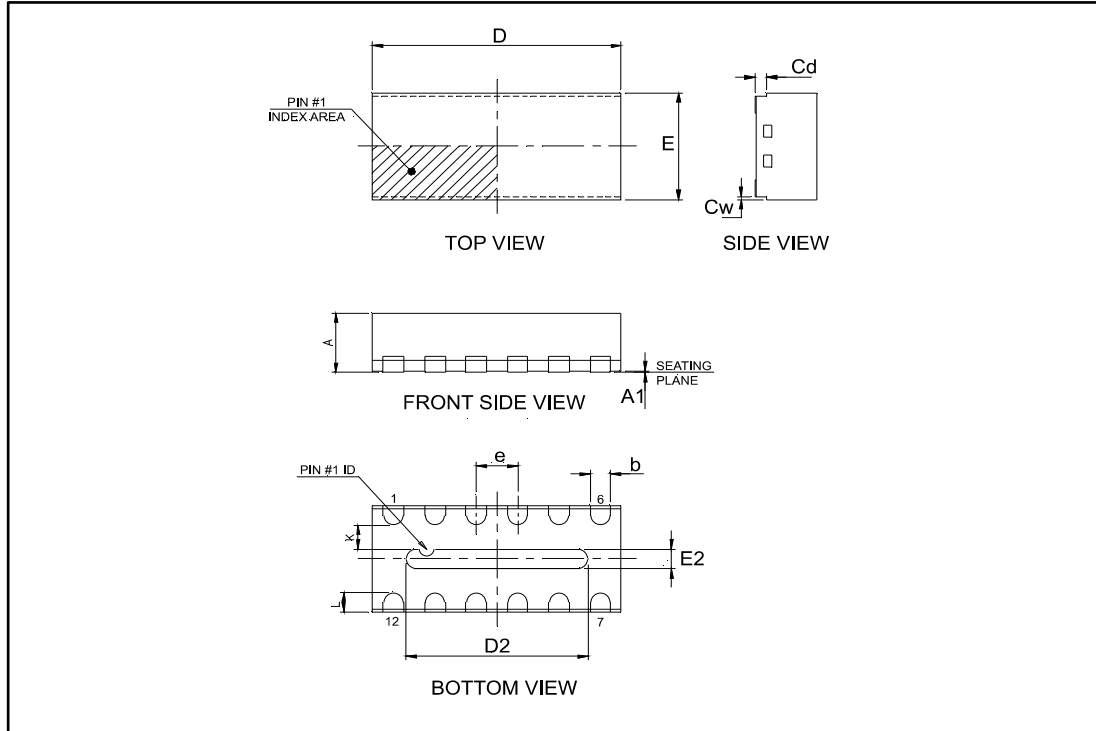

Table 3: QFN-12L package mechanical data

Ref.	Dimensions		
	Millimeters		
	Min.	Typ.	Max.
A	0.70	0.75	0.80
A1	0.00	0.02	0.05
b	0.18	0.25	0.30
D	2.95	3.00	3.05
E	1.30	1.35	1.40
D2	2.10	2.20	2.30
E2	0.20	0.25	0.30
e		0.50	
K	0.20		
L	0.20	0.25	0.30
Cd	0.1		
Cw	0.01		0.06

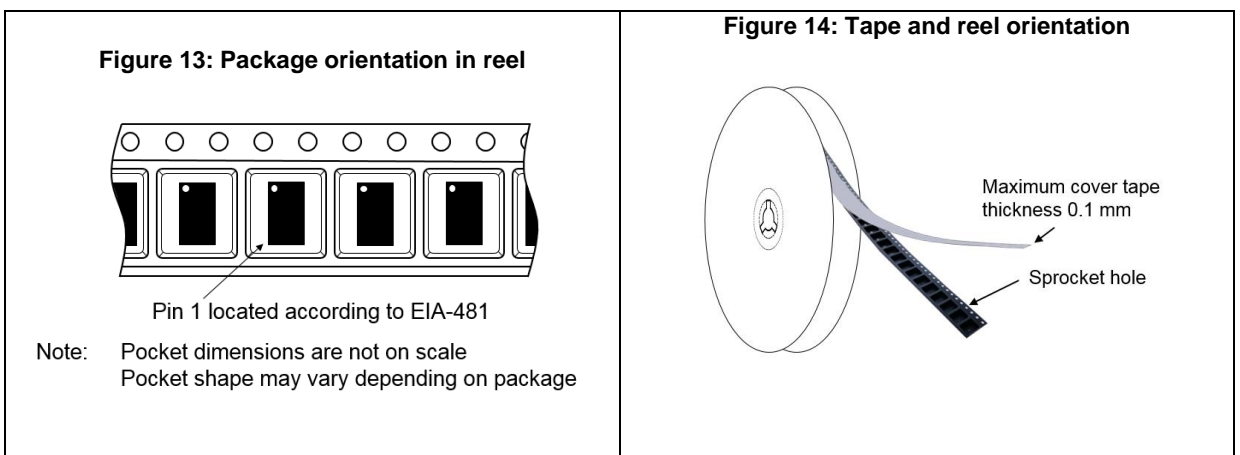
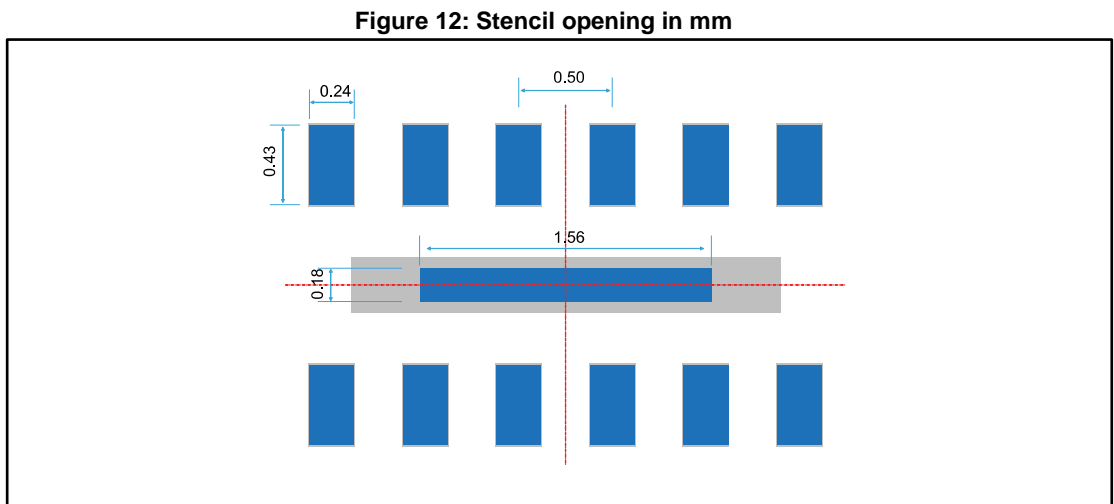
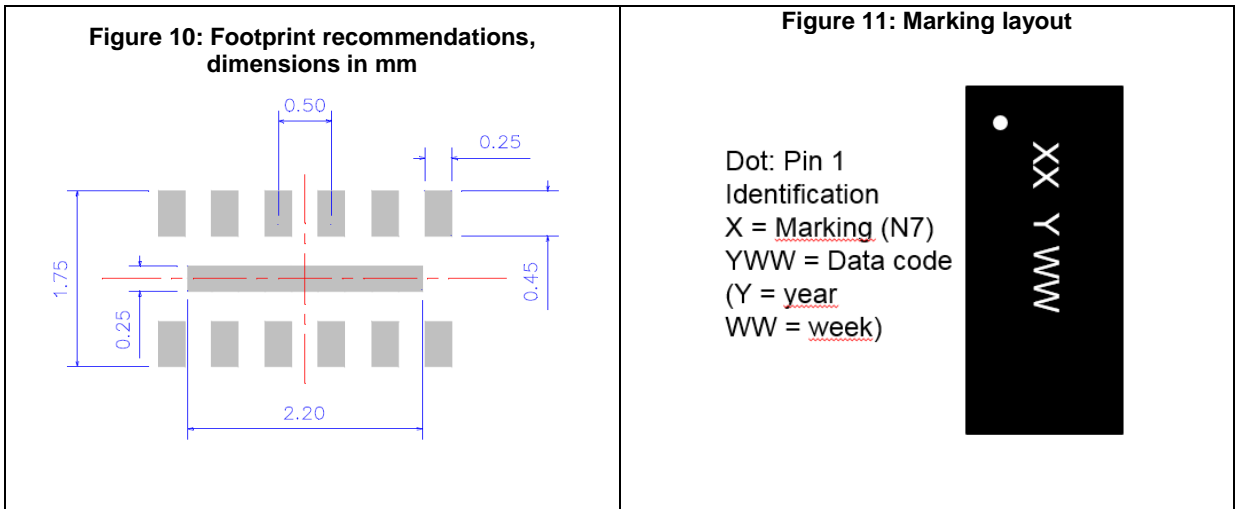

Figure 15: Reel dimensions in mm

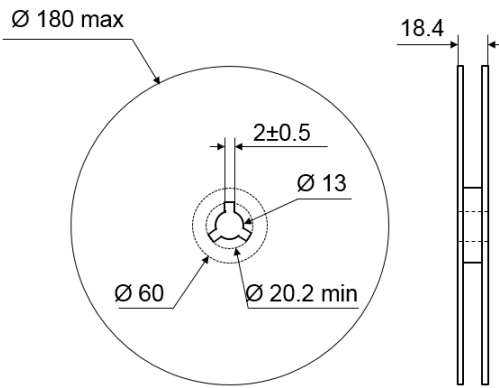

Figure 16: Inner box dimension definition in mm

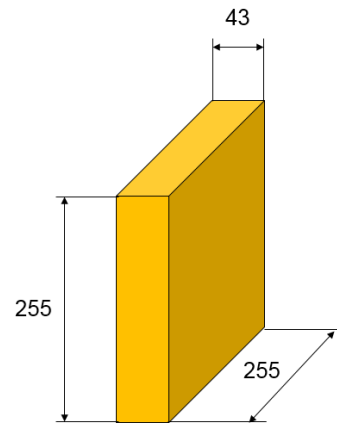
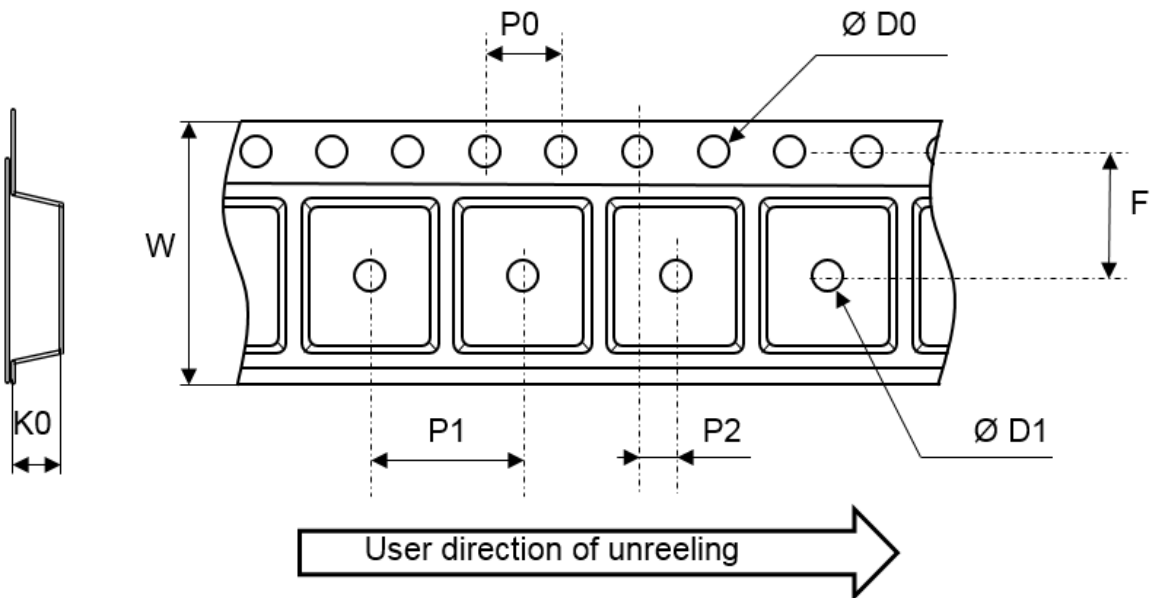

Figure 17: Tape dimension definitions



Note: Pocket dimensions are not on scale
 Pocket shape may vary depending on package

Table 4: Tape mechanical data

Ref.	Dimensions		
	Millimeters		
	Min.	Typ.	Max.
P1	3.9	4.0	4.1
P0	3.9	4.0	4.1
P2	1.95	2	2.05
Ø D0	1.5		
Ø D1	1		
F	5.45	5.50	5.55
K0	0.9	0.95	1.0
W	11.9	12	12.3

Figure 18: ST ECOPACK® recommended soldering reflow profile for PCB mounting

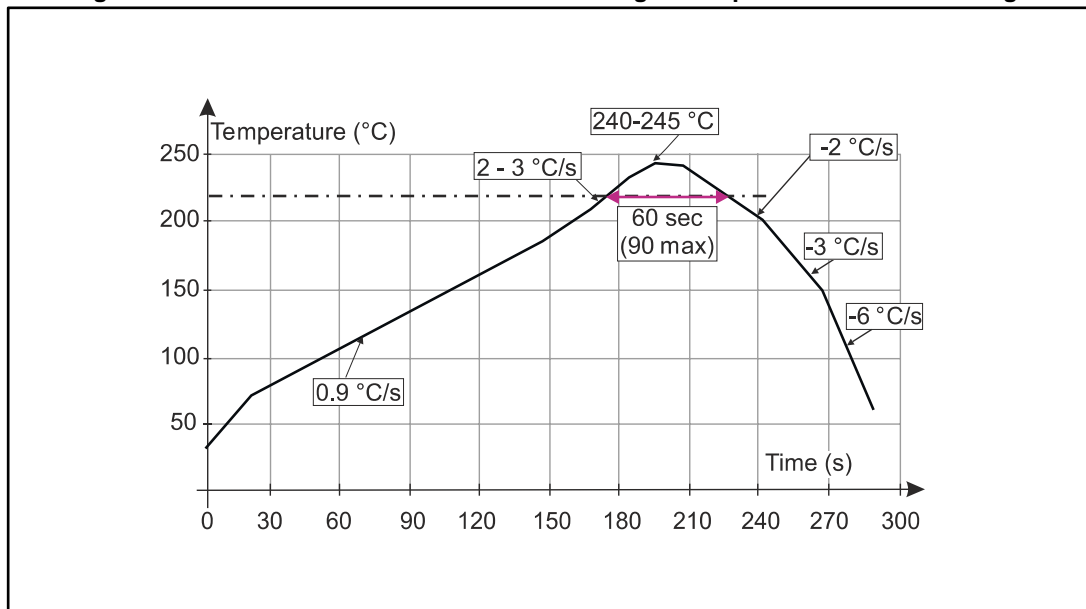

Minimize air convection currents in the reflow oven to avoid component movement. Maximum soldering profile corresponds to the latest IPC/JEDEC J-STD-020.

3 Ordering information

Figure 19: Ordering information scheme

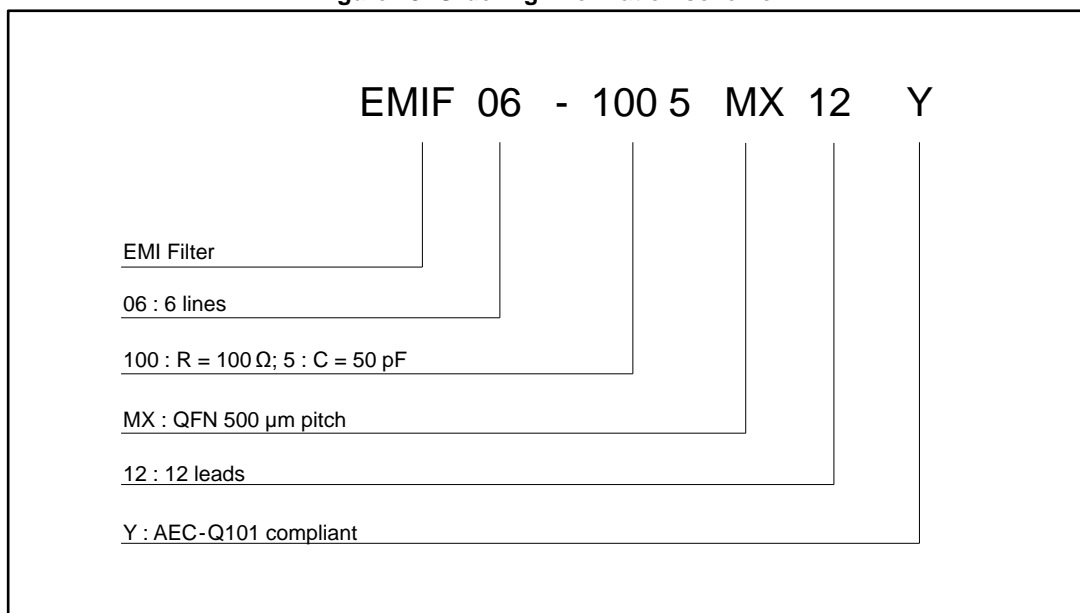

Table 5: Ordering information

Order code	Marking	Package	Weight	Base qty.	Delivery mode
EMIF06-1005MX12Y	N7	QFN-12L wettable flank	8.41 mg	3000	Tape and reel

4 Revision history

Table 6: Document revision history

Date	Revision	Changes
03-Mar-2017	1	Initial release.
06-Apr-2017	2	Updated Table 1 : "Absolute ratings (limiting values at Tamb = 25 °C unless otherwise specified)", Figure 4 : "S21 attenuation measurement" and Figure 5 : "Analog cross talk measurements".

IMPORTANT NOTICE – PLEASE READ CAREFULLY

STMicroelectronics NV and its subsidiaries ("ST") reserve the right to make changes, corrections, enhancements, modifications, and improvements to ST products and/or to this document at any time without notice. Purchasers should obtain the latest relevant information on ST products before placing orders. ST products are sold pursuant to ST's terms and conditions of sale in place at the time of order acknowledgement.

Purchasers are solely responsible for the choice, selection, and use of ST products and ST assumes no liability for application assistance or the design of Purchasers' products.

No license, express or implied, to any intellectual property right is granted by ST herein.

Resale of ST products with provisions different from the information set forth herein shall void any warranty granted by ST for such product.

ST and the ST logo are trademarks of ST. All other product or service names are the property of their respective owners.

Information in this document supersedes and replaces information previously supplied in any prior versions of this document.

© 2017 STMicroelectronics – All rights reserved

X-ON Electronics

Largest Supplier of Electrical and Electronic Components

Click to view similar products for [EMI Filter Circuits](#) category:

Click to view products by [STMicroelectronics](#) manufacturer:

Other Similar products are found below :

[761280-1](#) [SBSGC0500224MXB](#) [SBSPP0250104MXT](#) [SBSPP0250154MXT](#) [SBSPP0500473MXT](#) [SBSPP1000102MXT](#)
[SBSPP1000153MXB](#) [SBSPP1000220MCT](#) [SBSPP1000332MXT](#) [SBSPP1000470MCT](#) [SBSPP1000471MCT](#) [SBSPP1000472MXT](#)
[SNZF220DFT1G](#) [CM1442-06CP](#) [EMI8041MUTAG](#) [SBSPP0500473MXB](#) [SBSPP0500683MXT](#) [SBSPP1000101MCT](#) [SBSPP1000220MCB](#)
[SBSPP1000221MCT](#) [EMIF06-USD05F3](#) [EMIF03-SIM03F3](#) [EMI7112FCTAG](#) [EMI7403FCTBG](#) [EMI2180MTTBG](#) [CM1442-08CP](#)
[CSPEMI204FCTAG](#) [SBSPP1000152MXT](#) [SBSGC5000473MXT](#) [SBSMC0500474MXT](#) [SBSMC1000334MXT](#) [EMI8043MUTAG](#)
[MEA2010PE360T001](#) [NFA18SL307V1A45L](#) [1-6609037-5](#) [CM1690-06DE](#) [EMIF05-SK01F3](#) [EMIF02-USB03F2](#) [BNX022-01L](#)
[BNX024H01L](#) [BNX025H01L](#) [BNX026H01L](#) [NFA21SL806X1A48L](#) [NFL18SP157X1A3D](#) [NFL21SP106X1C3D](#) [NFL21SP207X1C3D](#)
[NFL21SP307X1C3D](#) [NFL21SP506X1C3D](#) [NFL21SP706X1C3D](#) [NFW31SP207X1E4L](#)