

4 x 49 W quad bridge car radio amplifier

Datasheet - production data

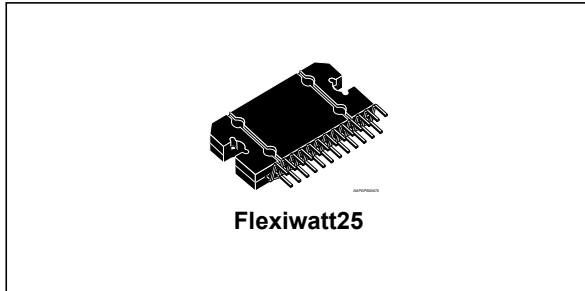

Features

- High output power capability:
- 4 x 49 W/4 Ω max.
- 4 x 28 W/4 Ω @ 14.4V, 1 kHz, 10%
- 4 x 24 W/4 Ω @ 13.2V, 1 kHz, 10%
- Low distortion
- Low output noise
- Standby function
- Mute function
- Automute at min. supply voltage detection
- Low external component count:

- Internally fixed gain (26dB)
- No external compensation
- No bootstrap capacitors
- Protections:
 - Output short circuit to GND, to V_S , across the load
 - Very inductive loads
 - Overtating chip temperature with soft thermal limiter
 - Load dump voltage
 - Fortuitous open GND
 - Reversed battery
 - ESD

Description

The TDA7386 is an AB class audio power amplifier, packaged in Flexiwatt 25 and designed for high end car radio applications.

Based on a fully complementary PNP/NPN configuration, the TDA7386 allows a rail to rail output voltage swing with no need of bootstrap capacitors. The extremely reduced boundary components count allows very compact sets.

Table 1. Device summary

Order code	Package	Packing
TDA7386	Flexiwatt25	Tube

Contents

1	Block and pin connection diagrams	5
2	Electrical specifications	6
2.1	Absolute maximum ratings	6
2.2	Thermal data	6
2.3	Electrical characteristics	6
2.4	PCB and component layout	8
2.5	Electrical characteristics curves	9
3	Application hints	11
3.1	SVR	11
3.2	Input stage	11
3.3	Standby and muting	11
4	Package information	12
5	Revision history	13

List of tables

Table 1.	Device summary	1
Table 2.	Absolute maximum ratings	6
Table 3.	Thermal data	6
Table 4.	Electrical characteristics	6
Table 5.	Document revision history.	13

List of figures

Figure 1.	Block diagram	5
Figure 2.	Pin connection (top view)	5
Figure 3.	Standard test and application circuit	7
Figure 4.	Components and top copper layer	8
Figure 5.	Bottom copper layer	8
Figure 6.	Quiescent current vs. supply voltage	9
Figure 7.	Quiescent output voltage vs. supply voltage.	9
Figure 8.	Output power vs. supply voltage.	9
Figure 9.	Max. output power vs. supply voltage.	9
Figure 10.	Distortion vs. output power	9
Figure 11.	Distortion vs. frequency	9
Figure 12.	Supply voltage rejection vs. frequency	10
Figure 13.	Crosstalk vs. frequency.	10
Figure 14.	Output noise vs. source resistance.	10
Figure 15.	Power dissipation and efficiency vs. output power	10
Figure 16.	Flexiwatt25 mechanical data and package dimensions	12

1 Block and pin connection diagrams

Figure 1. Block diagram

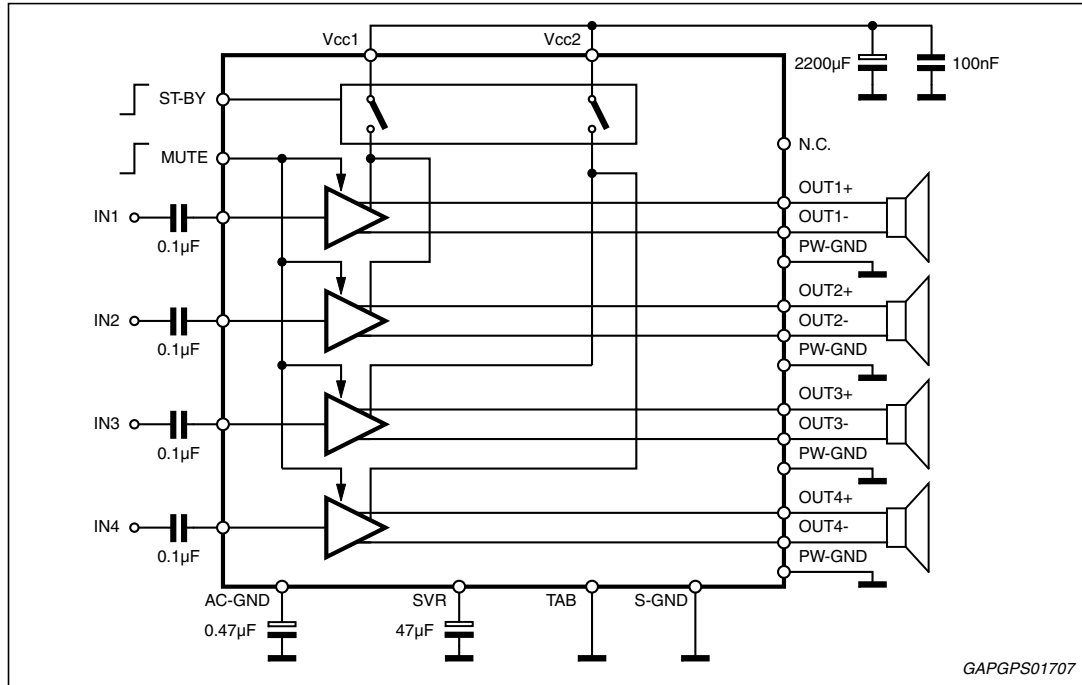
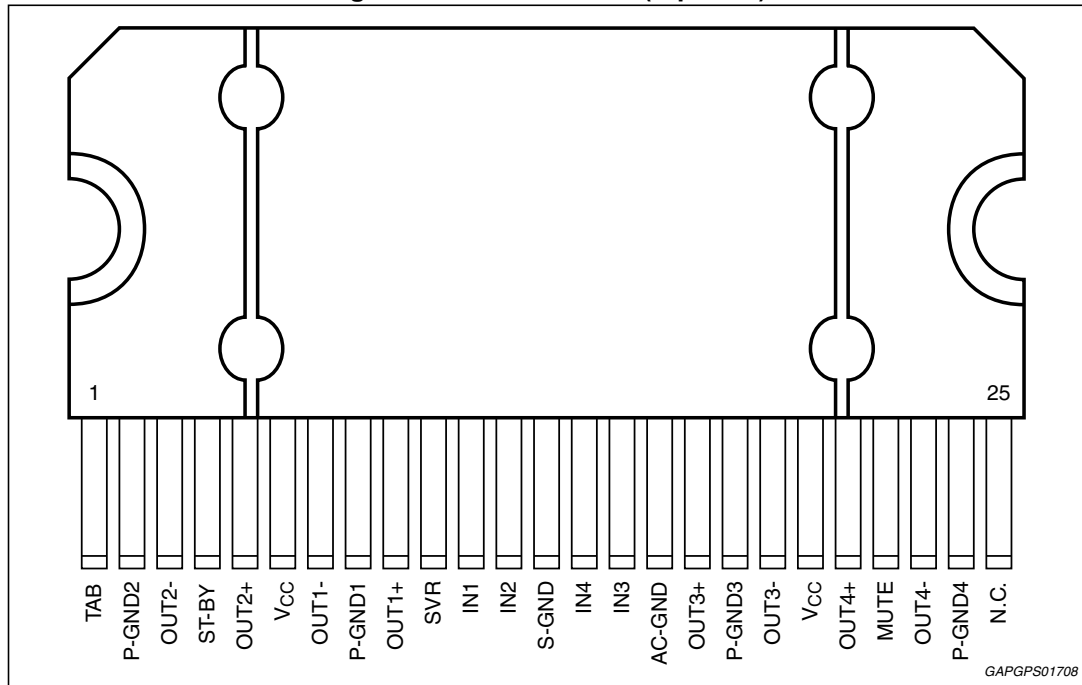

Figure 2. Pin connection (top view)



2 Electrical specifications

2.1 Absolute maximum ratings

Table 2. Absolute maximum ratings

Symbol	Parameter	Value	Unit
V_{CC}	Operating supply voltage	18	V
$V_{CC(DC)}$	DC supply voltage	28	V
$V_{CC(pk)}$	Peak supply voltage (t = 50 ms)	50	V
I_O	Output peak current: Repetitive (Duty Cycle 10% at f = 10 Hz)	4.5	A
	Non Repetitive (t = 100 μ s)	5.5	A
P_{tot}	Power dissipation, ($T_{case} = 70\text{ }^{\circ}\text{C}$)	80	W
T_{amb}	Operating temperature range	- 40 to 105	$^{\circ}\text{C}$
T_j	Junction temperature	150	$^{\circ}\text{C}$
T_{stg}	Storage temperature	- 55 to 150	$^{\circ}\text{C}$

2.2 Thermal data

Table 3. Thermal data

Symbol	Parameter	Value	Unit
$R_{th\ j-case}$	Thermal resistance junction-to-case max.	1	$^{\circ}\text{C/W}$

2.3 Electrical characteristics

$V_S = 14.4\text{ V}$; f = 1 kHz; $R_g = 600\ \Omega$; $R_L = 4\ \Omega$; $T_{amb} = 25\text{ }^{\circ}\text{C}$; Refer to the test and application diagram, unless otherwise specified.

Table 4. Electrical characteristics

Symbol	Parameter	Test condition	Min.	Typ.	Max.	Unit
I_{q1}	Quiescent current	$R_L = \infty$	-	190	350	mA
V_{OS}	Output offset voltage	Play Mode	-	-	± 80	mV
ΔV_{OS}	During mute on/off output offset voltage	-	-	-	± 80	mV
G_v	Voltage gain	-	25	26	27	dB
ΔG_v	Channel gain unbalance	-	-	-	± 1	dB
P_o	Output power	THD = 10%; $V_S = 13.2\text{ V}$	22	24	-	W
		THD = 0.8%; $V_S = 13.2\text{ V}$	16.5	18	-	W
		THD = 10%; $V_S = 14.4\text{ V}$	26	28	-	W

Table 4. Electrical characteristics (continued)

Symbol	Parameter	Test condition	Min.	Typ.	Max.	Unit
$P_{O\ max}$	Max.output power ⁽¹⁾	$V_S = 14.4\ V$ $V_S = 15.2\ V$	43	45 49	-	W
THD	Distortion	$P_O = 4\ W$	-	0.04	0.15	%
e_{No}	Output noise	"A" Weighted	-	50	70	μV
		Bw = 20 Hz to 20 kHz	-	70	100	μV
SVR	Supply voltage rejection	$f = 100\ Hz; V_r = 1V_{rms}$	50	75	-	dB
f_{ch}	High cut-off frequency	$P_O = 0.5\ W$	80	200	-	kHz
R_i	Input impedance	-	70	100	-	k Ω
C_T	Cross talk	$f = 1\ kHz; P_O = 4\ W$	60	70	-	dB
		$f = 10\ kHz; P_O = 4\ W$	-	60	-	dB
I_{SB}	Standby current consumption	$V_{St-by} = 1.5$	-	-	50	μA
		$V_{St-by} = 0\ V$	-	-	20	μA
I_{pin4}	Standby pin current	$V_{St-by} = 1.5\ to\ 3.5\ V$	-	-	± 1	μA
$V_{SB\ out}$	Standby out threshold voltage	(Amp: on)	3.5	-	-	V
$V_{SB\ in}$	Standby in threshold voltage	(Amp: off)	-	-	1.5	V
A_M	Mute attenuation	$P_{Oref} = 4\ W$	80	90	-	dB
$V_{M\ out}$	Mute out threshold voltage	(Amp: play)	3.5	-	-	V
$V_{M\ in}$	Mute in threshold voltage	(Amp: mute)	-	-	1.5	V
$V_{AM\ in}$	V_S automute threshold	(Amp: mute); Att $\geq 80\ dB; P_{Oref} = 4\ \Omega$	-	-	6.5	V
		(Amp: play); Att $< 0.1\ dB; P_O = 0.5\ \Omega$	-	7.6	8.5	V
I_{pin22}	Muting pin current	$V_{MUTE} = 1.5\ V$ (Source current)	5	11	20	μA
		$V_{MUTE} = 3.5\ V$	-5	-	20	μA

1. Saturated square wave output.

Figure 3. Standard test and application circuit

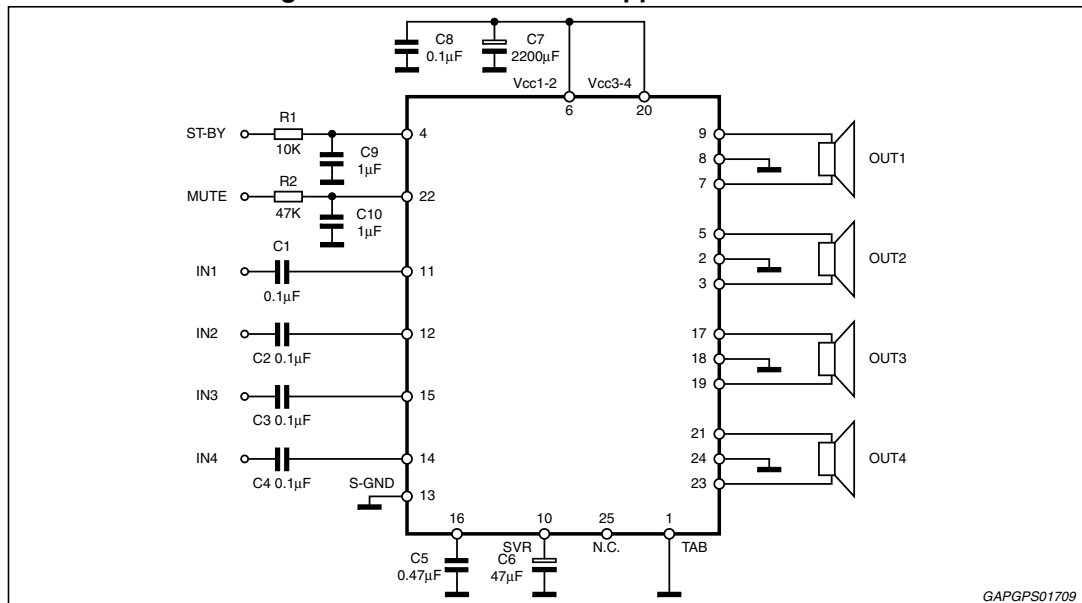

2.4 PCB and component layout

Referred to the circuit of [Figure 3](#).

Figure 4. Components and top copper layer

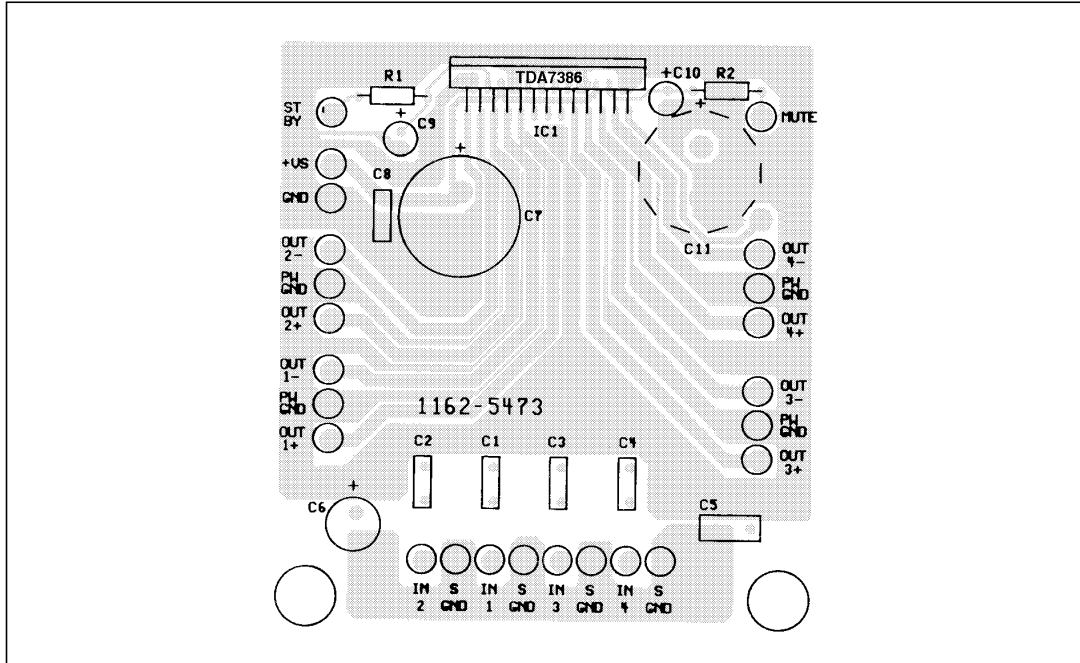
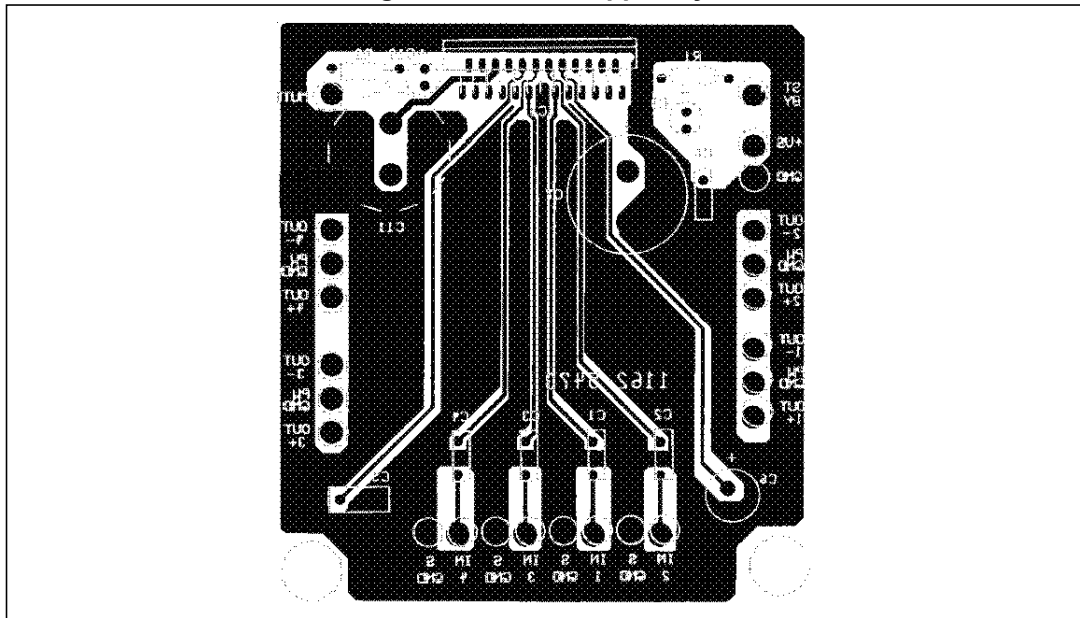

Figure 5. Bottom copper layer



2.5 Electrical characteristics curves

Figure 6. Quiescent current vs. supply voltage

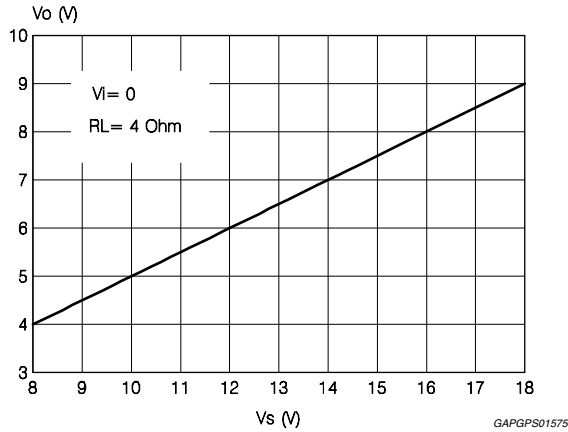

Figure 7. Quiescent output voltage vs. supply voltage

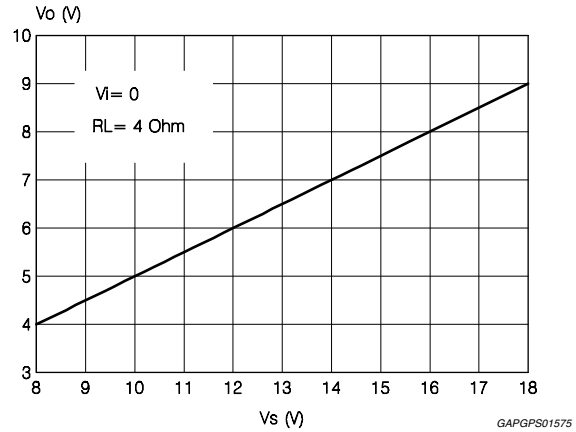

Figure 8. Output power vs. supply voltage

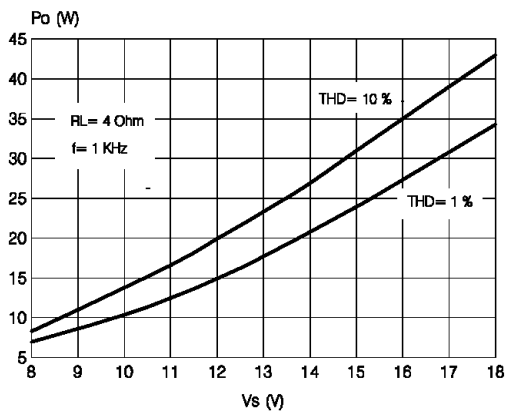

Figure 9. Max. output power vs. supply voltage

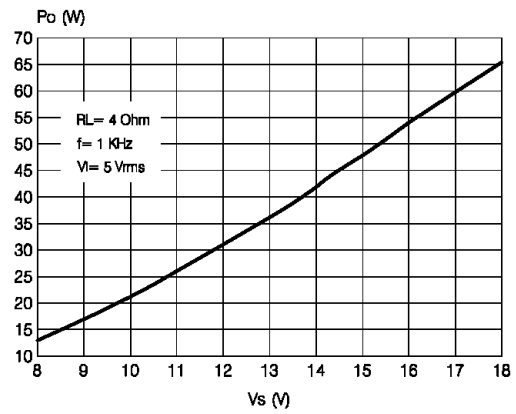

Figure 10. Distortion vs. output power

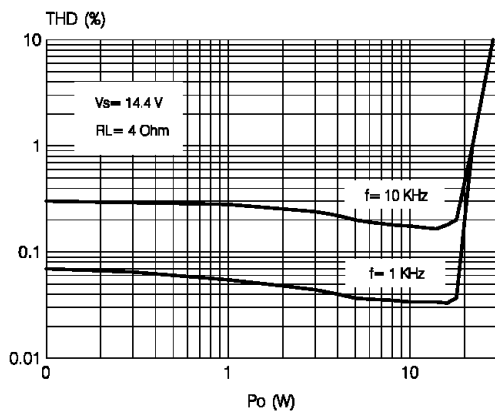

Figure 11. Distortion vs. frequency

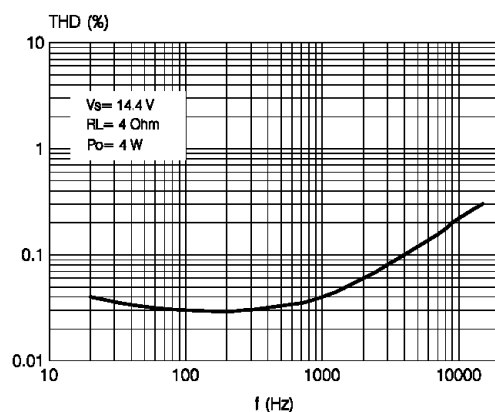

Figure 12. Supply voltage rejection vs. frequency

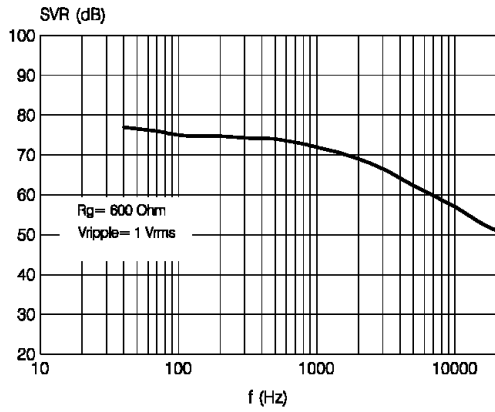

Figure 13. Crosstalk vs. frequency

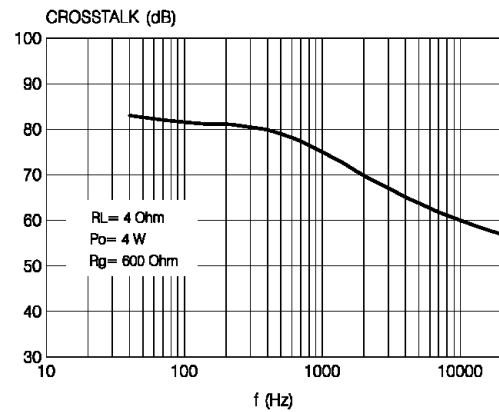

Figure 14. Output noise vs. source resistance

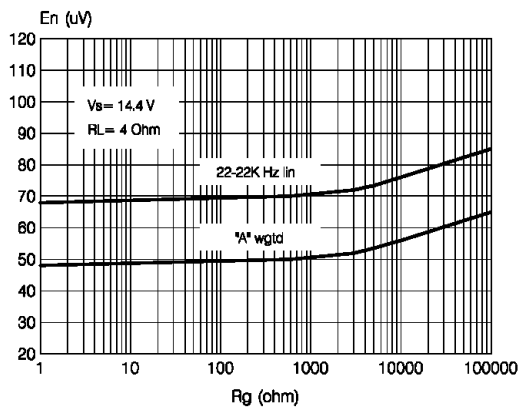
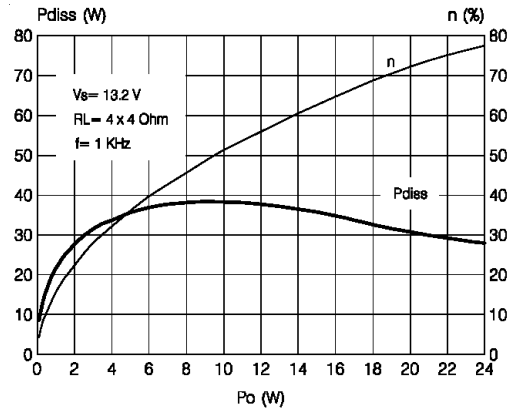

Figure 15. Power dissipation and efficiency vs. output power



3 Application hints

Referred to the circuit of [Figure 3](#).

3.1 SVR

Besides its contribution to the ripple rejection, the SVR capacitor governs the turn ON/OFF time sequence and, consequently, plays an essential role in the pop optimization during ON/OFF transients.

To conveniently serve both needs, **ITS MINIMUM RECOMMENDED VALUE IS 10 μ F.**

3.2 Input stage

The TDA7386's inputs are ground-compatible and can stand very high input signals (± 8 Vpk) without any performances degradation.

If the standard value for the input capacitors (0.1 μ F) is adopted, the low frequency cut-off will amount to 16 Hz.

3.3 Standby and muting

Standby and muting facilities are both CMOS-compatible. If unused, a straight connection to Vs of their respective pins would be admissible.

Conventional/low-power transistors can be employed to drive muting and stand-by pins in absence of true CMOS ports or microprocessors. R-C cells have always to be used in order to smooth down the transitions for preventing any audible transient noises.

Since a DC current of about 10 μ A normally flows out of pin 22, the maximum allowable muting-series resistance (R_2) is 70 k Ω , which is sufficiently high to permit a muting capacitor reasonably small (about 1 μ F).

If R_2 is higher than recommended, the involved risk will be that the voltage at pin 22 may rise to above the 1.5 V threshold voltage and the device will consequently fail to turn OFF when the mute line is brought down.

About the stand-by, the time constant to be assigned in order to obtain a virtually pop-free transition has to be slower than 2.5V/ms.

4 Package information

In order to meet environmental requirements, ST offers these devices in different grades of ECOPACK® packages, depending on their level of environmental compliance. ECOPACK® specifications, grade definitions and product status are available at: www.st.com.

ECOPACK® is an ST trademark.

Figure 16. Flexiwatt25 mechanical data and package dimensions

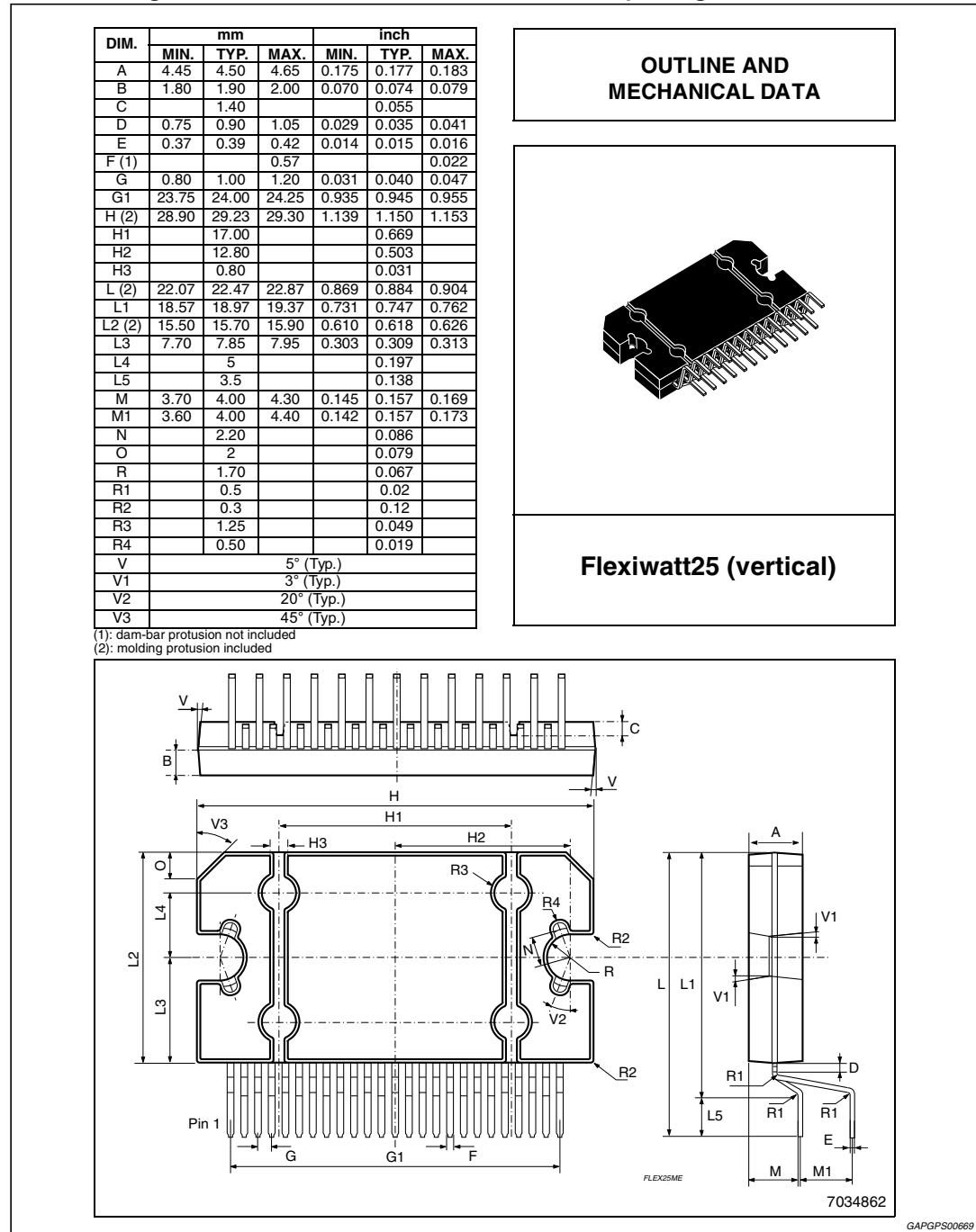

5 Revision history

Table 5. Document revision history

Date	Revision	Changes
24-Nov-2001	1	Initial release.
20-Dec-2007	2	Document reformatted. Modified the <i>Features on page 1</i> . Modified the <i>Figure 1</i> and <i>2</i> . Updated the <i>Table 4: Electrical characteristics</i> .
29-Oct-2008	3	Updated the <i>Table 3: Thermal data on page 6</i> .
19-Nov-2008	4	Update the <i>Table 2: Absolute maximum ratings on page 6</i> .
18-Sep-2013	5	Updated <i>Features on page 1</i> ; Updated <i>Table 4: Electrical characteristics</i> . Updated Disclaimer.

Please Read Carefully:

Information in this document is provided solely in connection with ST products. STMicroelectronics NV and its subsidiaries ("ST") reserve the right to make changes, corrections, modifications or improvements, to this document, and the products and services described herein at any time, without notice.

All ST products are sold pursuant to ST's terms and conditions of sale.

Purchasers are solely responsible for the choice, selection and use of the ST products and services described herein, and ST assumes no liability whatsoever relating to the choice, selection or use of the ST products and services described herein.

No license, express or implied, by estoppel or otherwise, to any intellectual property rights is granted under this document. If any part of this document refers to any third party products or services it shall not be deemed a license grant by ST for the use of such third party products or services, or any intellectual property contained therein or considered as a warranty covering the use in any manner whatsoever of such third party products or services or any intellectual property contained therein.

UNLESS OTHERWISE SET FORTH IN ST'S TERMS AND CONDITIONS OF SALE ST DISCLAIMS ANY EXPRESS OR IMPLIED WARRANTY WITH RESPECT TO THE USE AND/OR SALE OF ST PRODUCTS INCLUDING WITHOUT LIMITATION IMPLIED WARRANTIES OF MERCHANTABILITY, FITNESS FOR A PARTICULAR PURPOSE (AND THEIR EQUIVALENTS UNDER THE LAWS OF ANY JURISDICTION), OR INFRINGEMENT OF ANY PATENT, COPYRIGHT OR OTHER INTELLECTUAL PROPERTY RIGHT.

ST PRODUCTS ARE NOT DESIGNED OR AUTHORIZED FOR USE IN: (A) SAFETY CRITICAL APPLICATIONS SUCH AS LIFE SUPPORTING, ACTIVE IMPLANTED DEVICES OR SYSTEMS WITH PRODUCT FUNCTIONAL SAFETY REQUIREMENTS; (B) AERONAUTIC APPLICATIONS; (C) AUTOMOTIVE APPLICATIONS OR ENVIRONMENTS, AND/OR (D) AEROSPACE APPLICATIONS OR ENVIRONMENTS. WHERE ST PRODUCTS ARE NOT DESIGNED FOR SUCH USE, THE PURCHASER SHALL USE PRODUCTS AT PURCHASER'S SOLE RISK, EVEN IF ST HAS BEEN INFORMED IN WRITING OF SUCH USAGE, UNLESS A PRODUCT IS EXPRESSLY DESIGNATED BY ST AS BEING INTENDED FOR "AUTOMOTIVE, AUTOMOTIVE SAFETY OR MEDICAL" INDUSTRY DOMAINS ACCORDING TO ST PRODUCT DESIGN SPECIFICATIONS. PRODUCTS FORMALLY ESCC, QML OR JAN QUALIFIED ARE DEEMED SUITABLE FOR USE IN AEROSPACE BY THE CORRESPONDING GOVERNMENTAL AGENCY.

Resale of ST products with provisions different from the statements and/or technical features set forth in this document shall immediately void any warranty granted by ST for the ST product or service described herein and shall not create or extend in any manner whatsoever, any liability of ST.

ST and the ST logo are trademarks or registered trademarks of ST in various countries.

Information in this document supersedes and replaces all information previously supplied.

The ST logo is a registered trademark of STMicroelectronics. All other names are the property of their respective owners.

© 2013 STMicroelectronics - All rights reserved

STMicroelectronics group of companies

Australia - Belgium - Brazil - Canada - China - Czech Republic - Finland - France - Germany - Hong Kong - India - Israel - Italy - Japan - Malaysia - Malta - Morocco - Philippines - Singapore - Spain - Sweden - Switzerland - United Kingdom - United States of America

www.st.com

X-ON Electronics

Largest Supplier of Electrical and Electronic Components

Click to view similar products for [Audio Amplifiers](#) category:

Click to view products by [STMicroelectronics](#) manufacturer:

Other Similar products are found below :

[LV47002P-E](#) [NCP2811AFCT1G](#) [NCP2890AFCT2G](#) [SSM2377ACBZ-R7](#) [IS31AP4915A-QFLS2-TR](#) [NCP2820FCT2G](#) [TDA1591T](#)
[TDA7563AH](#) [SSM2529ACBZ-R7](#) [SSM2518CBZ-R7](#) [MAX9890AETA+T](#) [TS2012EIJT](#) [NCP2809BMUTXG](#) [NJW1157BFC2](#)
[SSM2375CBZ-REEL7](#) [IS31AP4996-GRLS2-TR](#) [STPA002OD-4WX](#) [NCP2823BFCT1G](#) [MAX9717DETA+T](#) [MAX9717CETA+T](#)
[MAX9724AEBC+TG45](#) [LA4450L-E](#) [IS31AP2036A-CLS2-TR](#) [MAX9723DEBE+T](#) [TDA7563ASMTR](#) [AS3561-DWLT](#) [SSM2517CBZ-R7](#)
[MP1720DH-12-LF-P](#) [SABRE9601K](#) [THAT1646W16-U](#) [MAX98396EWB+](#) [PAM8965ZLA40-13](#) [BD37532FV-E2](#) [BD5638NUX-TR](#)
[BD37512FS-E2](#) [BD37543FS-E2](#) [BD3814FV-E2](#) [TPA3140D2PWPR](#) [TS2007EIJT](#) [IS31AP2005-DLS2-TR](#) [SSM2518CPZ-R7](#) [AS3410-EQFP-](#)
[500](#) [FDA4100LV](#) [MAX98306ETD+T](#) [TS4994EIJT](#) [NCP2820FCT1G](#) [NCP2823AFCT2G](#) [NCS2211MNTXG](#) [CPA2233CQ16-A1](#)
[OPA1604AIPWR](#)