High power microstepping motor driver with the L6482H

Data brief

**Features**

- Voltage range from 10.5 V to 85 V
- Low $R_{ds(ON)}$ MOSFETs in DPAK package
- SPI with daisy chain feature
- FLAG and BUSY LED indicators
- Flexible supply voltage management
- Suitable for use in combination with the STEVAL-PCC009V2

Applications

- High power bipolar stepper motor driving

Description

The EVAL6482H demonstration board is a high power microstepping motor driver. In combination with the STEVAL-PCC009V2 communication board and the evaluation software, the board allows the user to investigate all the features of the L6482 device. In particular, the board can be used to check the advanced current control and to regulate the L6482 parameters in order to fit the application requirements.

The EVAL6482H supports the daisy chain configuration making it suitable for the evaluation of the L6482 in multi motor applications.

Board description

Table 1. EVAL6482H electrical specifications

Parameter	Value
Supply voltage (VS)	10.5 to 85 V
Maximum output current (each phase)	6 A _{r.m.s.} at 25 °C ⁽¹⁾
External MOSFET R _{ds(ON)}	33 mΩ typical at 25 °C ⁽²⁾
Gate driver supply voltage (VCC)	7.5 V to 15 V
Logic supply voltage	3.3 V
Logic interface supply voltage	3.3 V or 5 V
Low level logic input	0 V
High level logic input	VDD ⁽³⁾
Operating temperature	-25 °C to +125 °C

1. Limited by the mounted sensing resistors.
2. Refer to STD25NF10 datasheet for details.
3. All logic inputs are 5 V tolerant.

Figure 1. Jumper and connector location

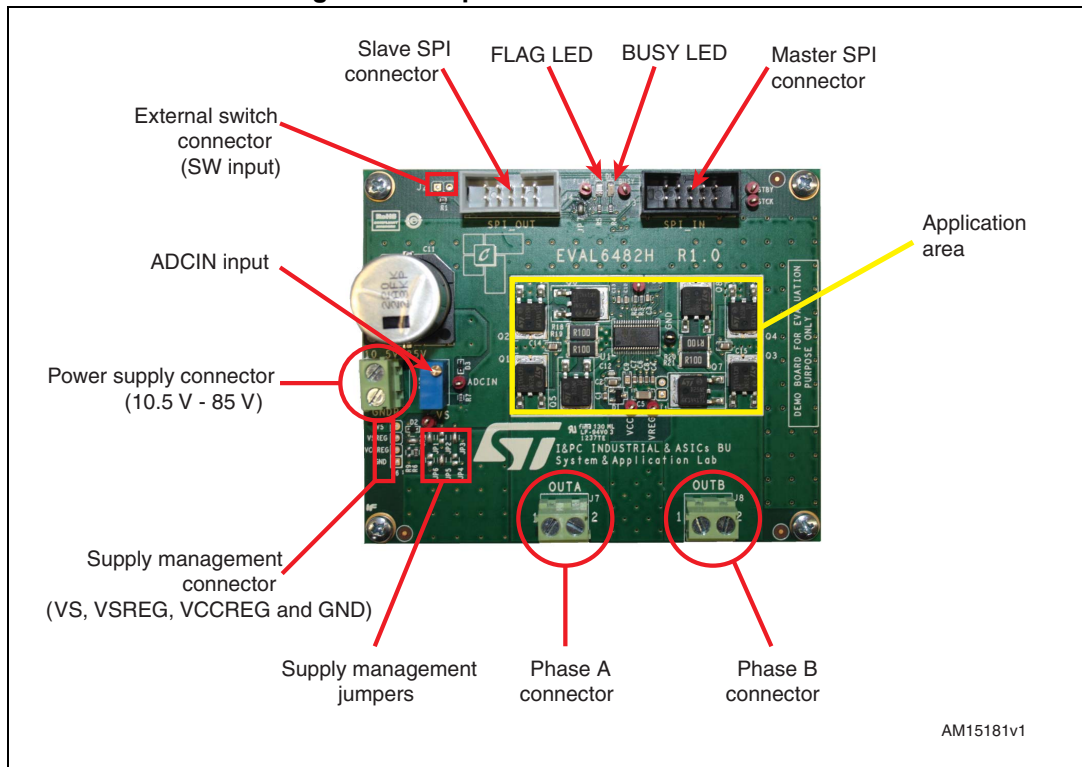

AM15181v1

Table 2. Jumper and connector description

Name	Type	Function
J5	Power supply	Main supply voltage
J7	Power output	Power bridge A outputs
J8	Power output	Power bridge B outputs
J6	Power supply	Integrated voltage regulator inputs
J3	SPI	Master SPI connector
J4	SPI	Slave SPI connector
JP1	Jumper	VS to VSREG jumper
JP2	Jumper	VSREG to VCC jumper
JP3	Jumper	VCC to VCCREG jumper
JP4	Jumper	VCCREG to VREG jumper
JP5	Jumper	VREG to VDD jumper
JP6	Jumper	VDD to 3.3 V from SPI connector jumper
JP7	Jumper	Daisy chain termination jumper
JP8	Jumper	STBY to VS pull-up jumper

Table 3. Master SPI connector pinout (J3)

Pin number	Type	Description
1	Open drain output	L6482 BUSY output
2	Open drain output	L6482 FLAG output
3	Ground	Ground
4	Supply	EXT_VDD (can be used as external logic power supply)
5	Digital output	SPI "Master In Slave Out" signal (connected to the L6482 SDO output through daisy chain termination jumper JP7)
6	Digital input	SPI serial clock signal (connected to L6482 CK input)
7	Digital input	SPI "Master Out Slave In" signal (connected to L6482 SDI input)
8	Digital input	SPI slave select signal (connected to L6482 CS input)
9	Digital input	L6482 step-clock input
10	Digital input	L6482 standby/reset input

Table 4. Slave SPI connector pinout (J4)

Pin number	Type	Description
1	Open drain output	L6482 BUSY output
2	Open drain output	L6482 FLAG output
3	Ground	Ground
4	Supply	EXT_VDD (can be used as external logic power supply)
5	Digital output	SPI "Master In Slave Out" signal (connected to pin 5 of J3)
6	Digital input	SPI serial clock signal (connected to L6482 CK input)
7	Digital input	SPI "Master Out Slave In" signal (connected to L6482 SDO output)
8	Digital input	SPI slave select signal (connected to L6482 CS input)
9	Digital input	L6482 step-clock input
10	Digital input	L6482 standby/reset input

Figure 2. EVAL6482H schematic - part 1/2

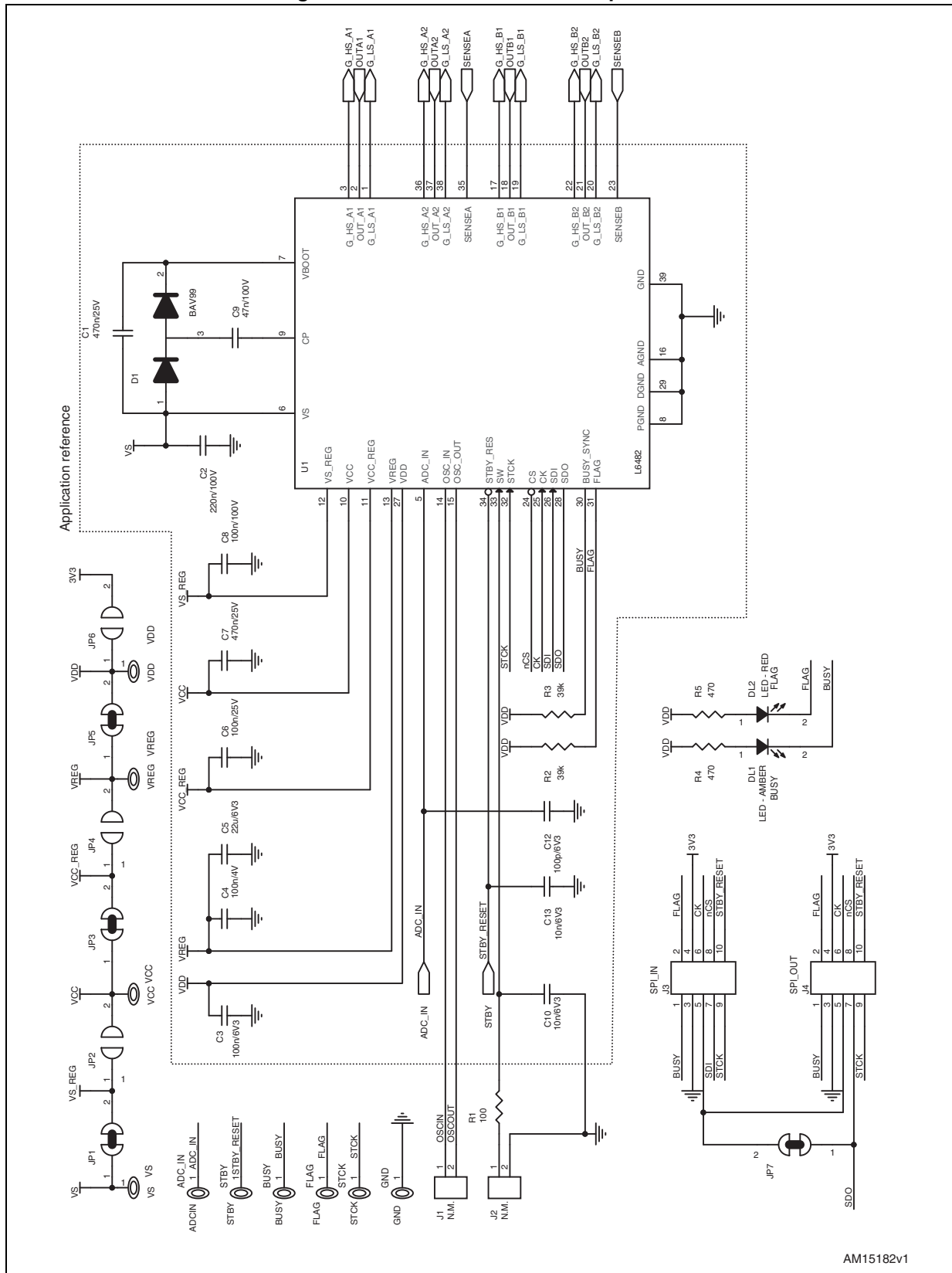

Figure 3. EVAL6482H schematic - part 2/2

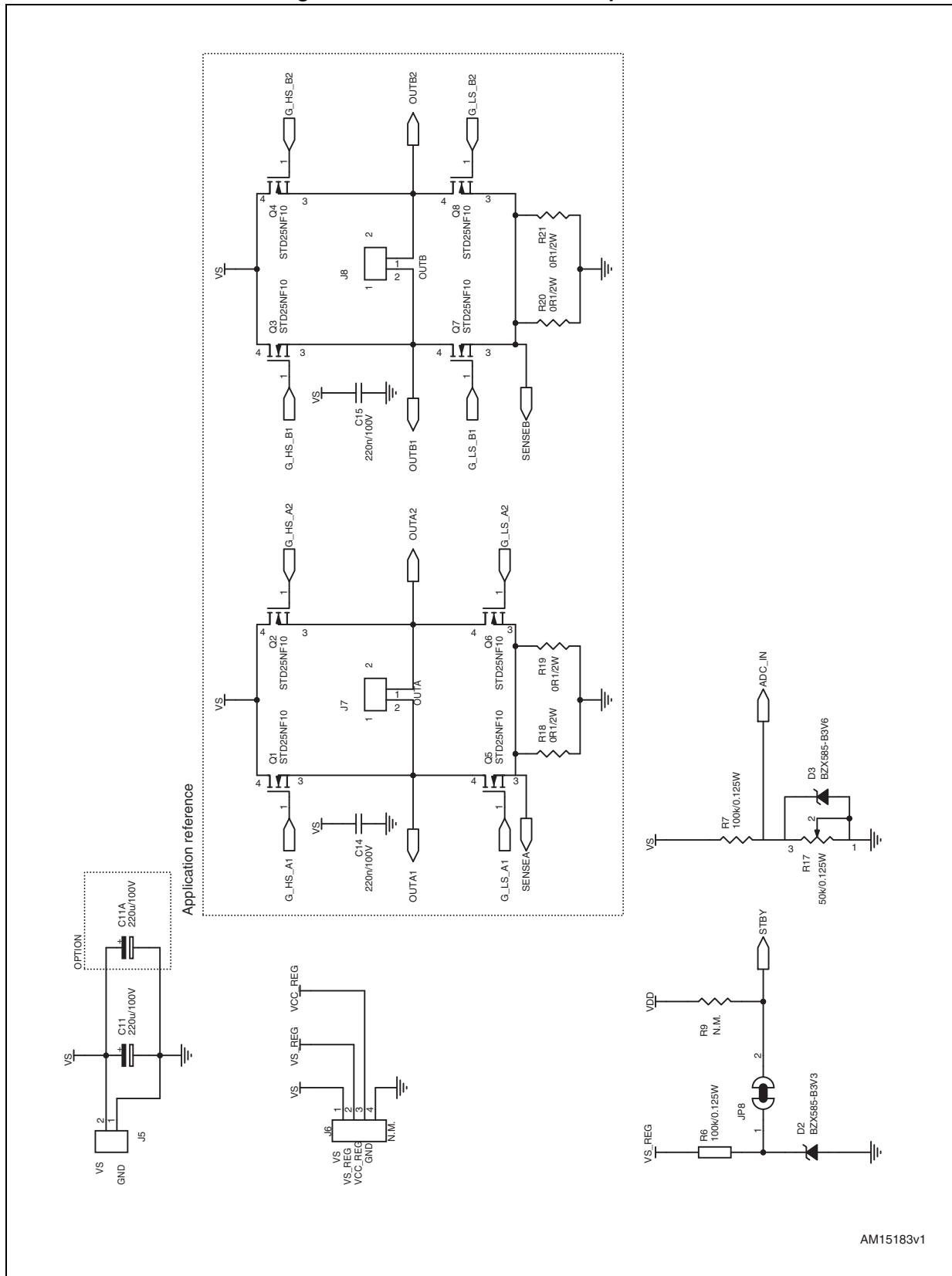

Table 5. EVAL6482H - bill of material

Item	Quantity	Reference	Value	Package
1	9	VS, VREG, VDD, VCC, STCK, STBY, FLAG, BUSY, ADCIN	TPTH-RING (red)	TPTH-RING-1MM
2	1	GND	TP-RING (black)	TPTH-RING-1MM
3	2	C1,C7	470 nF/25 V	CAPC-0603
4	3	C2, C14, C15	220 nF/100 V	CAPC-0805
5	1	C3	100 nF/6.3 V	CAPC-0603
6	1	C4	100 nF/4 V	CAPC-0603
7	1	C5	22 μ F/6.3 V	CAPC-1206
8	1	C6	100 nF/25 V	CAPC-0603
9	1	C8	100 nF/100 V	CAPC-0603
10	1	C9	47 nF/100 V	CAPC-0805
11	2	C10, C13	10 nF/6.3 V	CAPC-0603
12	1	C11	220 μ F/100 V	CAPE-R18H17
13	1	C11A	220 μ F/100 V	CAPE-R16H21-P75
14	1	C12	100 pF/6.3 V	CAPC-0603
15	1	DL1	LED amber	LEDC-0805
16	1	DL2	LED red	LEDC-0805
17	1	D1	BAV99	SOT-23
18	1	D2	BZX585-B3V3	SOD523
19	1	D3	BZX585-B3V6	SOD523
20	5	JP1, JP3, JP5, JP7, JP8	Jumper CLOSED	JP2SO
21	3	JP2, JP4, JP6	Jumper OPEN	JP2SO
22	2	J1, J2	N. M.	STRIP254P-M-2
23	1	J3	Pol. IDC male header vertical 10 poles (black)	CON-FLAT-5X2-180M
24	1	J4	Pol. IDC male header vertical 10 poles (gray)	CON-FLAT-5X2-180M
25	3	J5, J7, J8	Screw connector 2 poles	MORSV-508-2P
26	1	J6	N. M.	STRIP254P-M-4
27	8	Q1, Q2, Q3, Q4, Q5, Q6, Q7, Q8	STD25NF10	DPAK
28	1	R1	100 Ω	RESC-0603
29	2	R2, R3	39 k Ω	RESC-0603
30	2	R4, R5	470 Ω	RESC-0603
31	2	R6, R7	100 k Ω / 0.125 W	RESC-0603

Table 5. EVAL6482H - bill of material (continued)

Item	Quantity	Reference	Value	Package
32	1	R9	N. M.	RESC-0603
33	1	R17	50 k Ω / 0.125 W	TRIMM-100X50X110-64W
34	4	R18, R19, R20, R21	0.1 Ω / 2 W	RESC-2010
35	1	U1	L6482	HTSSOP050P-660X110-38-EP

Figure 4. EVAL6482H - layout (top layer)

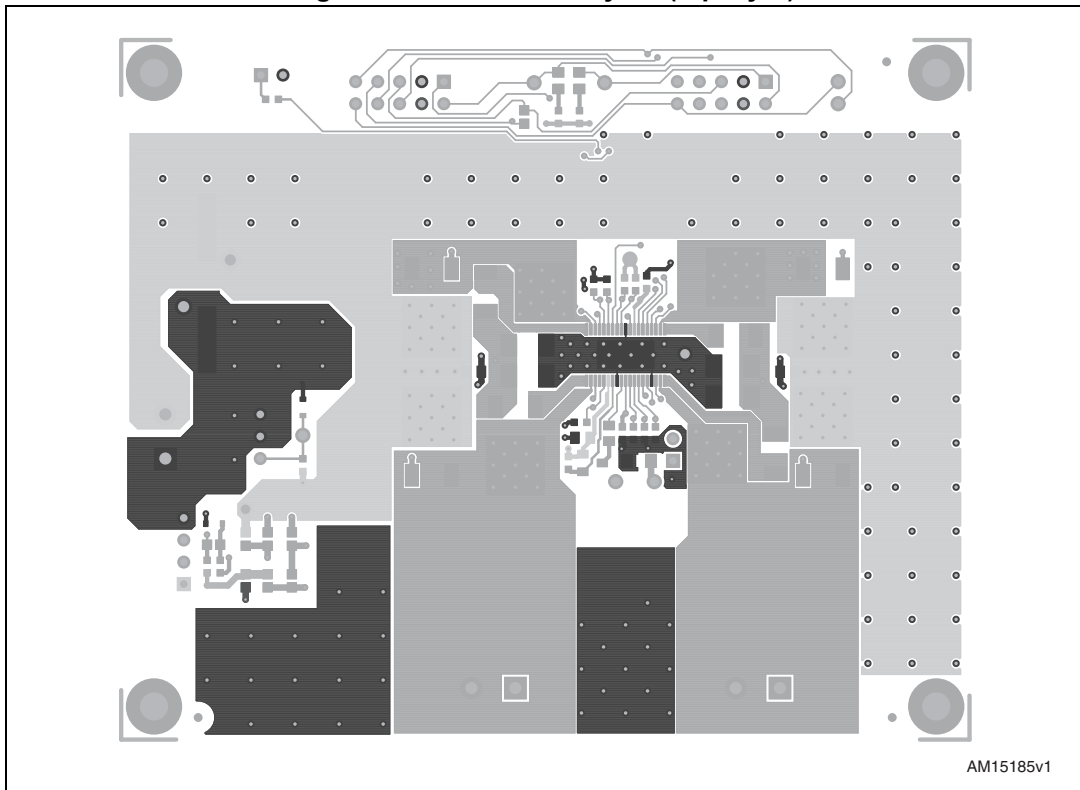

Figure 5. EVAL6482H - layout (inner layer 2)

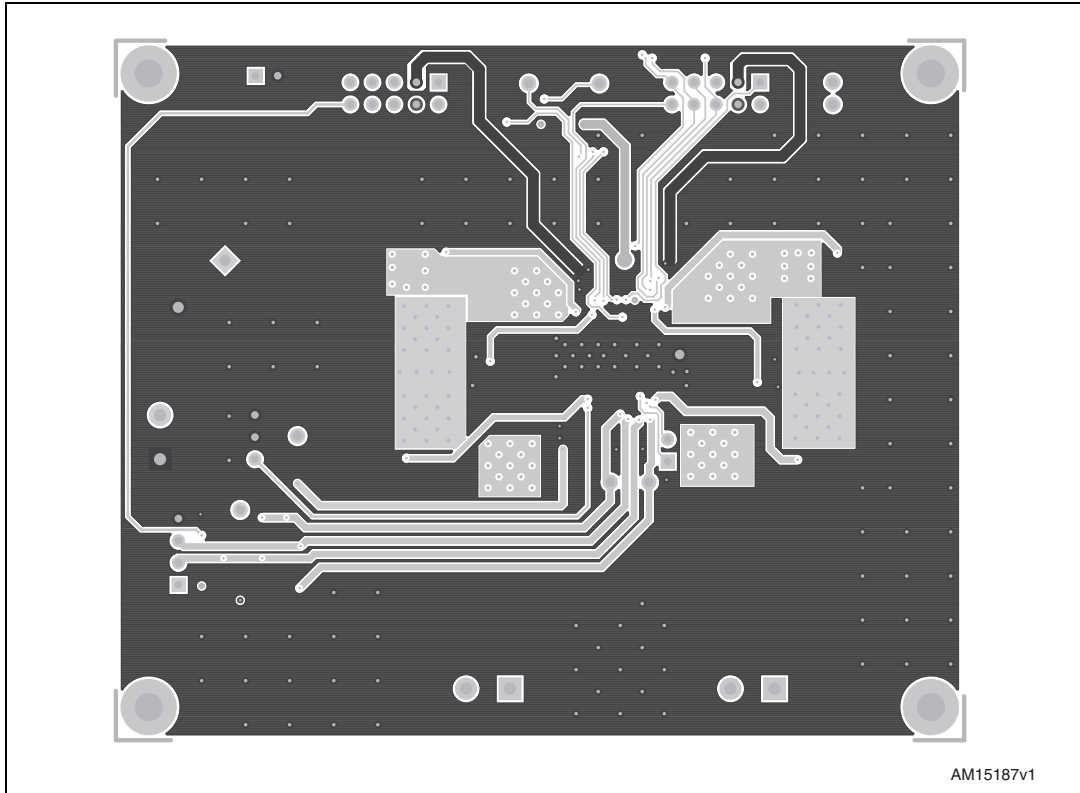

Figure 6. EVAL6482H - layout (inner layer 3)

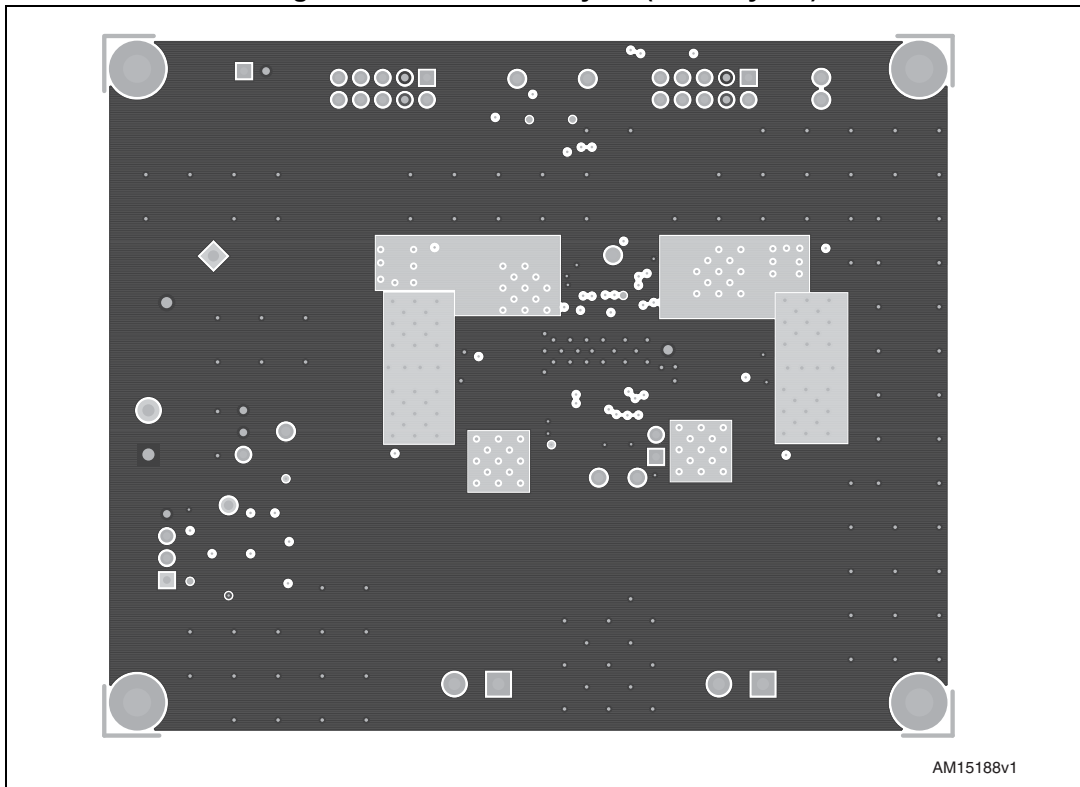
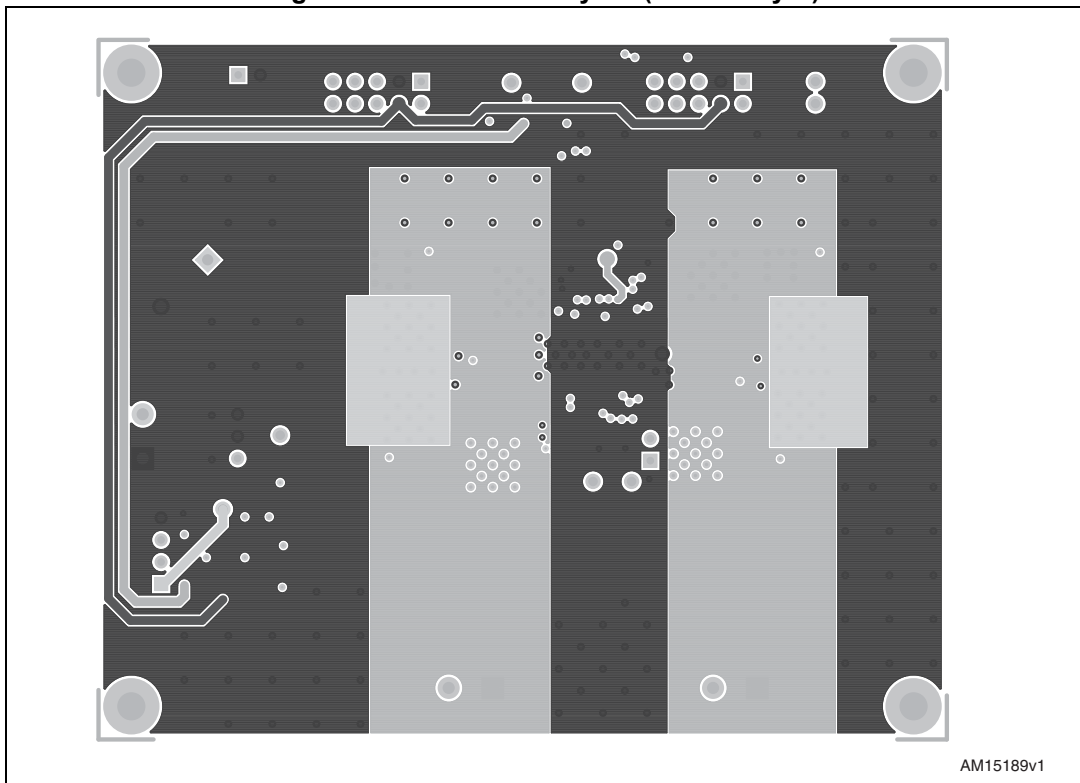

Figure 7. EVAL6482H - layout (bottom layer)



Revision history

Table 6. Document revision history

Date	Revision	Changes
30-Oct-2012	1	Initial release.
03-Apr-2015	2	Removed Figure 4. EVAL6482H - layout (silkscreen) from page 8. Minor modifications throughout document.

IMPORTANT NOTICE – PLEASE READ CAREFULLY

STMicroelectronics NV and its subsidiaries (“ST”) reserve the right to make changes, corrections, enhancements, modifications, and improvements to ST products and/or to this document at any time without notice. Purchasers should obtain the latest relevant information on ST products before placing orders. ST products are sold pursuant to ST’s terms and conditions of sale in place at the time of order acknowledgement.

Purchasers are solely responsible for the choice, selection, and use of ST products and ST assumes no liability for application assistance or the design of Purchasers’ products.

No license, express or implied, to any intellectual property right is granted by ST herein.

Resale of ST products with provisions different from the information set forth herein shall void any warranty granted by ST for such product.

ST and the ST logo are trademarks of ST. All other product or service names are the property of their respective owners.

Information in this document supersedes and replaces information previously supplied in any prior versions of this document.

© 2015 STMicroelectronics – All rights reserved

X-ON Electronics

Largest Supplier of Electrical and Electronic Components

Click to view similar products for [Power Management IC Development Tools](#) *category:*

Click to view products by [STMicroelectronics](#) *manufacturer:*

Other Similar products are found below :

[EVAL-ADM1168LQEBZ](#) [EVB-EP5348UI](#) [MIC23451-AAAYFL EV](#) [MIC5281YMME EV](#) [DA9063-EVAL](#) [ADP122-3.3-EVALZ](#) [ADP130-0.8-EVALZ](#) [ADP130-1.2-EVALZ](#) [ADP130-1.5-EVALZ](#) [ADP130-1.8-EVALZ](#) [ADP1714-3.3-EVALZ](#) [ADP1715-3.3-EVALZ](#) [ADP1716-2.5-EVALZ](#) [ADP1740-1.5-EVALZ](#) [ADP1752-1.5-EVALZ](#) [ADP1828LC-EVALZ](#) [ADP1870-0.3-EVALZ](#) [ADP1871-0.6-EVALZ](#) [ADP1873-0.6-EVALZ](#) [ADP1874-0.3-EVALZ](#) [ADP1882-1.0-EVALZ](#) [ADP199CB-EVALZ](#) [ADP2102-1.25-EVALZ](#) [ADP2102-1.875EVALZ](#) [ADP2102-1.8-EVALZ](#) [ADP2102-2-EVALZ](#) [ADP2102-3-EVALZ](#) [ADP2102-4-EVALZ](#) [ADP2106-1.8-EVALZ](#) [ADP2147CB-110EVALZ](#) [AS3606-DB](#) [BQ24010EVM](#) [BQ24075TEVM](#) [BQ24155EVM](#) [BQ24157EVM-697](#) [BQ24160EVM-742](#) [BQ24296MEVM-655](#) [BQ25010EVM](#) [BQ3055EVM](#) [NCV891330PD50GEVB](#) [ISLUSBI2CKIT1Z](#) [LM2744EVAL](#) [LM2854EVAL](#) [LM3658SD-AEV/NOPB](#) [LM3658SDEV/NOPB](#) [LM3691TL-1.8EV/NOPB](#) [LM4510SDEV/NOPB](#) [LM5033SD-EVAL](#) [LP38512TS-1.8EV](#) [EVAL-ADM1186-1MBZ](#)