

L5150GJ-L5300AH7-L4995AK Evaluation Board

Data brief

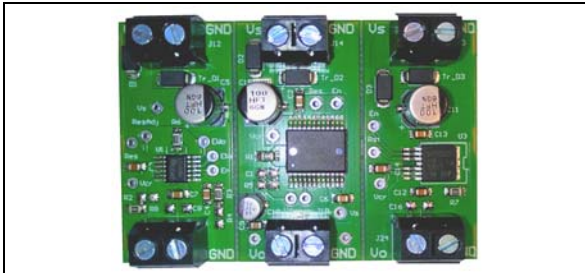

Features

Max transient supply voltage	V_{CC}	40 V ⁽¹⁾	
Max DC output voltage	V_o	5 V	
Output current	I_o	L5150GJ	150 mA
		L5300AH7	300 mA
		L4995AK	500mA
Quiescent current with regulator disabled	I_q	L5150GJ	5 μ A
		L5300AH7	
		L4995AK	3 μ A

1. Operating input voltage for L5150GJ and L5300AH7 and transients for L4995AK.

- Simple detachable application board dedicated for L5150GJ, L5300AH7 and L4995AK
- Provides electrical connectivity for easy prototyping
- General Device features:
 - Power on reset
 - Low voltage reset
 - Enable

- Early warning (only for L5150GJ)
- Protections
 - Thermal shutdown
 - Short circuit

Applications

To provide stable 5V supply in Automotive applications, BCM, Power Train, HVAC, Door Zone, Seat position, Electric park brake, Window lift, LED light control, Sun roof module, Gear box, and so on.

Description

The board has been designed to facilitate the evaluation of certified (according to AEC-Q100) Voltage Regulators for Automotive applications. The board offers an effective solution for fast system prototyping and device evaluation. The EV-AUTO-LDOS comes ready-to-use with the required capacitors on the VCC power supply line. On-board minimum set of electrical components enables the user to directly connect the load and the power supply without any additional effort in external component design and connection. The board can be used in a unique solution or split in three stand-alone parts. Each part is completely independent from the electronic point of view and allows the performance evaluation of a single voltage regulator.

Table 1. Device summary

Order Code	Reference
EV-AUTO-LDOS	L5150GJ, L5300AH7,L4995AK Evaluation Board

1 Overview

The board comes pre-assembled with L5150GJ, L5300AH7 and L4995AK voltage regulators designed to supply 5V automotive grounded loads, providing standard protections (such as Thermal shutdown and Short circuit).

Those ICs are housed in the following packages: HPAK for L5300AH7, PowerSSO-12 for L5150GJ and PowerSSO-24 for L4995AK.

The voltage regulators use a P-channel MOS transistor as a regulating element; with this structure a very low dropout voltage is obtained. The output voltage is regulated with a 2% precision.

The voltage regulator automatically adapts its own quiescent current to the output current level.

Figure 1. Evaluation board schematic L5150GJ

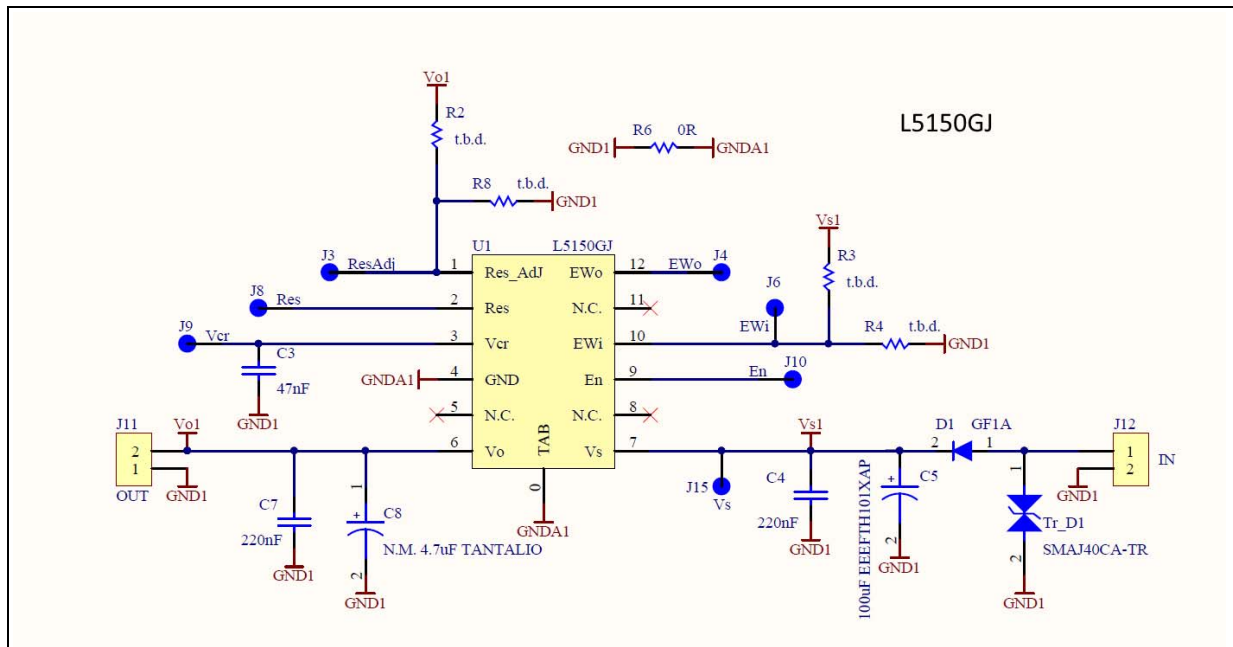

Figure 2. Evaluation board schematic L4995AK

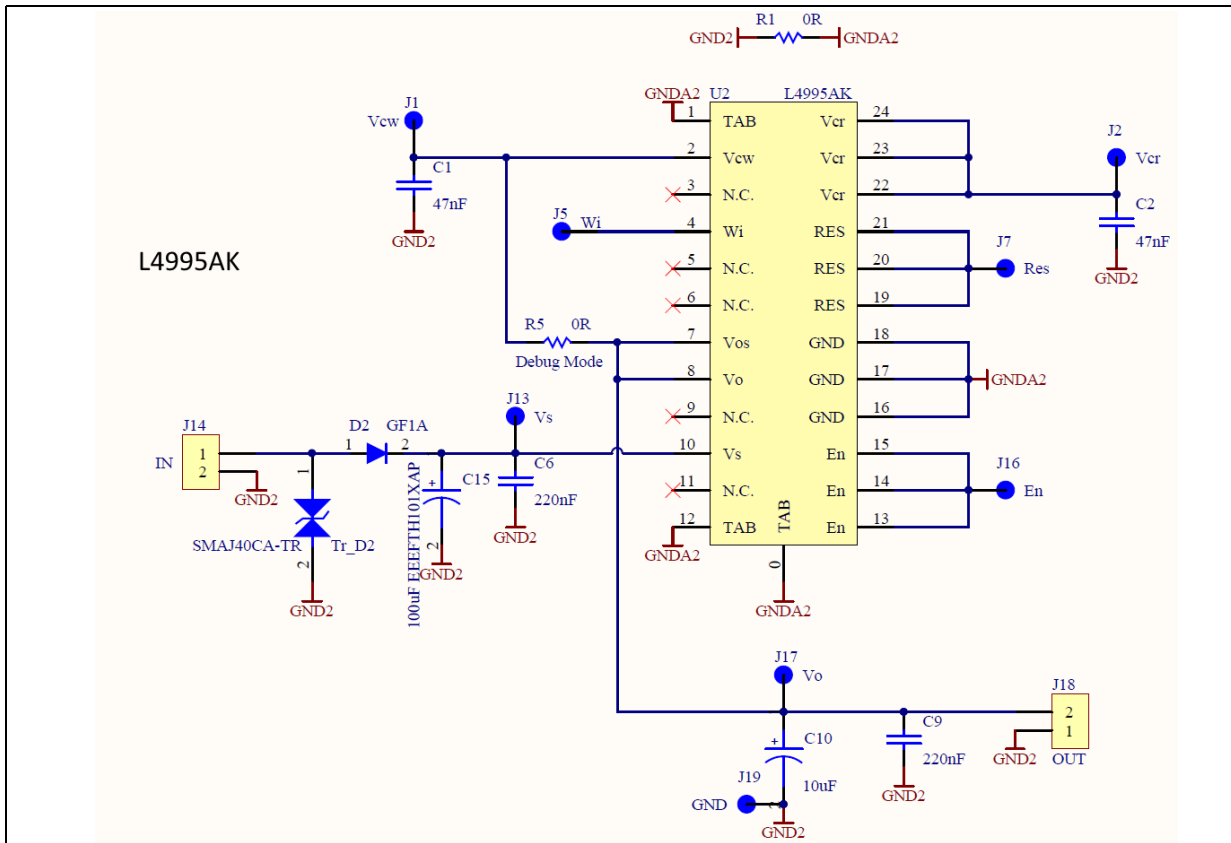
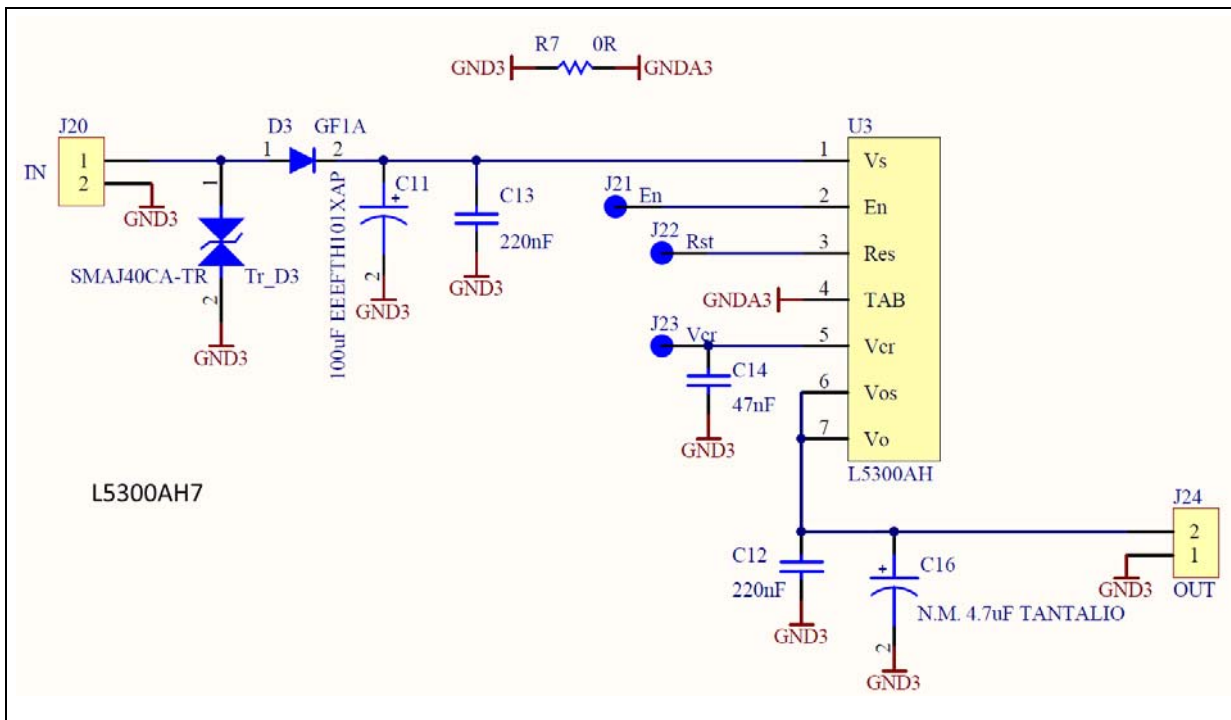

Figure 3. Evaluation board schematic L5300AH7



2 Board connections

Figure 4: Evaluation board connections shows the placement of the connectors to be used to supply the evaluation board and connecting the load.

Figure 4. Evaluation board connections

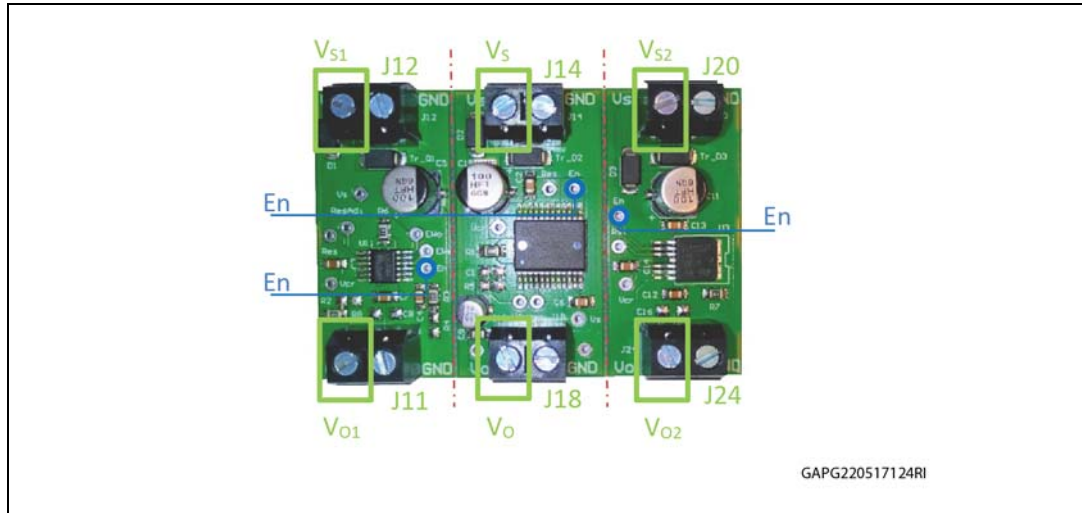

Table 2. Pin connection and function (L4995AK)

Connector	Pin number	Pin name	Pin function
J14	1	V _S	Input voltage
J14	2	GND2	Ground
J18	1	GND2	Ground
J18	2	V _O	5 V Regulated output voltage

Table 3. Pin connection and function (L5150GJ)

Connector	Pin number	Pin name	Pin function
J11	1	GND1	Ground
J11	2	V _{O1}	5 V Regulated output voltage
J12	1	V _{S1}	Input voltage
J12	2	GND1	Ground

Table 4. Pin connection and function (L5300AH7)

Connector	Pin number	Pin name	Pin function
J20	1	V _{S2}	Input voltage
J20	2	GND3	Ground

Table 4. Pin connection and function (L5300AH7) (continued)

Connector	Pin number	Pin name	Pin function
J24	1	GND3	Ground
J24	2	V _{O2}	5 V Regulated output voltage

All devices are supplied with an enable input, where a high signal switches the regulators on. When the enable pin is set to low the output is switched-off and the current consumption of the device is drastically reduced.

Specific configuration only for L5150GJ

- The Output Voltage Reset threshold can be adjusted via an external voltage divider (R2 and R8) according to the following formula:

$$V_{\text{thre}} = [(R2 + R8) / R8] * V_{\text{Res_adj}}$$

The Output Voltage Reset threshold can be decreased down to 3.5 V. Typical value for V_{Res_adj} is 2.5V^(a).

- The EWi input signal is compared with the internal voltage reference (typically 2.5 V). The use of an external voltage divider makes the comparator very flexible in the application. This function can be used to supervise the supply input voltage and to give additional information to the microprocessor such as low voltage warnings^(b).

a. The board is configured with the threshold of the Reset function to the default value of 8 % below Vo_ref typical (R8= 0 Ohm and R2 N.M.).

b. The board is configured with the Early Warning function deactivated (EWi pin latch to Vs1 by R3= 0 Ohm and R4 N.M.).

3 Thermal data

Table 5. EV-AUTO-LDOS thermal data

Symbol	Parameter	Max	Unit
Rthj-amb – L5150GJ	Thermal resistance junction-ambient (MAX)	55	°C/W
Rthj-amb – L5300AH7		45	
Rthj-amb – L4995AK		40	

Table 6. PCB specifications

Parameter		Value
Boards dimensions	EV-AUTO-LDOS	62 x 42 mm
	L5150GJ	20 x 42 mm
	L5300AH7	20 x 42 mm
	L4995AK	22 x 42 mm
Number of Cu layer		2
Layer Cu thickness		35 µm
Board finish thickness		1.6 mm +/- 10%
Board Material		FR4
Thermal vias separation		0.2 mm
Thermal vias diameter		1 mm

4 Revision history

Table 7. Document revision history

Date	Revision	Changes
06-Jun-2017	1	Initial release.

IMPORTANT NOTICE – PLEASE READ CAREFULLY

STMicroelectronics NV and its subsidiaries ("ST") reserve the right to make changes, corrections, enhancements, modifications, and improvements to ST products and/or to this document at any time without notice. Purchasers should obtain the latest relevant information on ST products before placing orders. ST products are sold pursuant to ST's terms and conditions of sale in place at the time of order acknowledgement.

Purchasers are solely responsible for the choice, selection, and use of ST products and ST assumes no liability for application assistance or the design of Purchasers' products.

No license, express or implied, to any intellectual property right is granted by ST herein.

Resale of ST products with provisions different from the information set forth herein shall void any warranty granted by ST for such product.

ST and the ST logo are trademarks of ST. All other product or service names are the property of their respective owners.

Information in this document supersedes and replaces information previously supplied in any prior versions of this document.

© 2017 STMicroelectronics – All rights reserved

X-ON Electronics

Largest Supplier of Electrical and Electronic Components

Click to view similar products for [Power Management IC Development Tools](#) category:

Click to view products by [STMicroelectronics](#) manufacturer:

Other Similar products are found below :

[EVAL-ADM1168LQEBZ](#) [EVB-EP5348UI](#) [MIC23451-AAAYFL EV](#) [MIC5281YMME EV](#) [DA9063-EVAL](#) [ADP122-3.3-EVALZ](#) [ADP130-0.8-EVALZ](#) [ADP130-1.2-EVALZ](#) [ADP130-1.5-EVALZ](#) [ADP130-1.8-EVALZ](#) [ADP1714-3.3-EVALZ](#) [ADP1715-3.3-EVALZ](#) [ADP1716-2.5-EVALZ](#) [ADP1740-1.5-EVALZ](#) [ADP1752-1.5-EVALZ](#) [ADP1828LC-EVALZ](#) [ADP1870-0.3-EVALZ](#) [ADP1871-0.6-EVALZ](#) [ADP1873-0.6-EVALZ](#) [ADP1874-0.3-EVALZ](#) [ADP1882-1.0-EVALZ](#) [ADP199CB-EVALZ](#) [ADP2102-1.25-EVALZ](#) [ADP2102-1.875EVALZ](#) [ADP2102-1.8-EVALZ](#) [ADP2102-2-EVALZ](#) [ADP2102-3-EVALZ](#) [ADP2102-4-EVALZ](#) [ADP2106-1.8-EVALZ](#) [ADP2147CB-110EVALZ](#) [AS3606-DB](#) [BQ24010EVM](#) [BQ24075TEVM](#) [BQ24155EVM](#) [BQ24157EVM-697](#) [BQ24160EVM-742](#) [BQ24296MEVM-655](#) [BQ25010EVM](#) [BQ3055EVM](#) [NCV891330PD50GEVB](#) [ISLUSBI2CKIT1Z](#) [LM2744EVAL](#) [LM2854EVAL](#) [LM3658SD-AEV/NOPB](#) [LM3658SDEV/NOPB](#) [LM3691TL-1.8EV/NOPB](#) [LM4510SDEV/NOPB](#) [LM5033SD-EVAL](#) [LP38512TS-1.8EV](#) [EVAL-ADM1186-1MBZ](#)