

## 100 V, 40 A field-effect rectifier diode

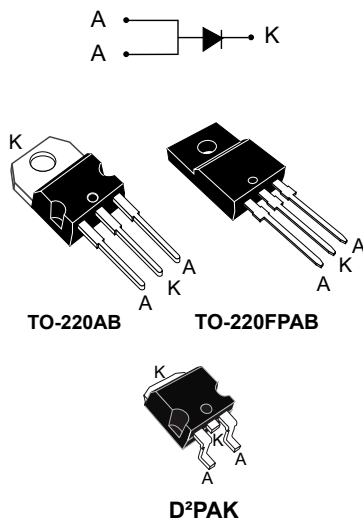

### Features

- ST patented rectifier process
- Stable leakage current over reverse voltage
- Low forward voltage drop
- High frequency operation
- ECOPACK<sup>®</sup>2 compliant

### Applications

- Adapter
- Gaming console power supply
- Battery charger
- DC / DC converter

### Description

This single rectifier is based on a proprietary technology, enabling to achieve the best in class  $V_F/I_R$  for a given silicon surface.

Packaged in TO-220AB, TO-220FPAB and D<sup>2</sup>PAK, the FERD40H100S is optimized for use in confined applications where both efficiency and thermal performance are key. With a lower dependency of leakage current ( $I_R$ ) and forward voltage ( $V_F$ ) in function of temperature, the thermal runaway risk is reduced. It is highly recommended to be used in adapters and chargers.

Product status	
FERD40H100S	
Product summary	
Symbol	Value
$I_{F(AV)}$	40 A
$V_{RRM}$	100 V
$T_{j(max.)}$	175 °C
$V_{F(typ.)}$	0.325 V

# 1 Characteristics

**Table 1. Absolute ratings (limiting values at 25 °C, unless otherwise specified, anode terminals short circuited)**

Symbol	Parameter	Value	Unit
$V_{RRM}$	Repetitive peak reverse voltage	100	V
$I_{F(RMS)}$	Forward rms current	60	A
$I_{F(AV)}$	Average forward current, $\delta = 0.5$ square wave	40	A
$I_{FSM}$	Surge non repetitive forward current	$t_p = 10$ ms sinusoidal	A
$T_{stg}$	Storage temperature range	-65 to +175	°C
$T_j$	Maximum operating junction temperature <sup>(1)</sup>	+175	°C

1.  $(dP_{tot}/dT_j) < (1/R_{th(j-a)})$  condition to avoid thermal runaway for a diode on its own heatsink.

**Table 2. Thermal resistance parameter**

Symbol	Parameter	Max. value	Unit
$R_{th(j-c)}$	Junction to case	TO-220AB, D <sup>2</sup> PAK	0.8
		TO-220FPAB	3.3

**Table 3. Static electrical characteristics (anode terminals short circuited)**

Symbol	Parameter	Test conditions	Min.	Typ.	Max.	Unit
$I_R^{(1)}$	Reverse leakage current	$T_j = 25$ °C	-	12	24	$\mu$ A
		$T_j = 125$ °C				
		$T_j = 125$ °C	$V_R = 70$ V	-	6	12
$V_F^{(2)}$	Forward voltage drop	$T_j = 25$ °C	-	0.380	0.430	V
		$T_j = 125$ °C				
		$T_j = 25$ °C	-	0.465	0.525	
		$T_j = 125$ °C				
		$T_j = 25$ °C	-	0.600	0.675	
		$T_j = 125$ °C				
		$T_j = 125$ °C	-	0.550	0.600	
$T_j = 125$ °C	-	0.645	0.705			

1. Pulse test:  $t_p = 5$  ms,  $\delta < 2\%$

2. Pulse test:  $t_p = 380$   $\mu$ s,  $\delta < 2\%$

To evaluate the conduction losses, use the following equation:

$$P = 0.420 \times I_{F(AV)} + 0.009 \times I_{F(RMS)}^2$$

For more information, please refer to the following application notes related to the power losses :

- AN604: Calculation of conduction losses in a power rectifier
- AN4021: Calculation of reverse losses on a power diode

### 1.1 Characteristics (curves)

**Figure 1. Average forward current versus case temperature ( $\delta = 0.5$ )**

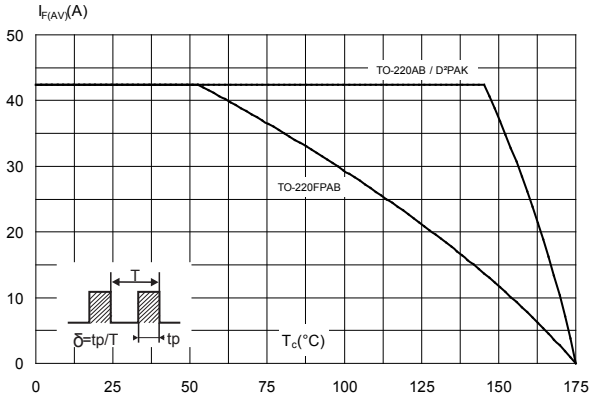

**Figure 2. Relative variation of thermal impedance junction to case versus pulse duration (TO-220AB, D<sup>2</sup>PAK)**

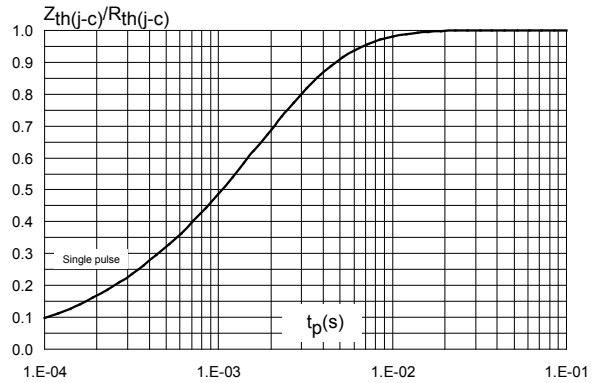

**Figure 3. Relative variation of thermal impedance junction to case versus pulse duration (TO-220FPAB)**

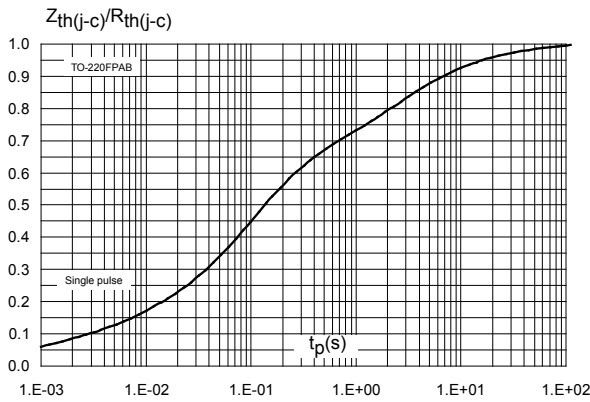

**Figure 4. Reverse leakage current versus reverse voltage applied (typical values)**

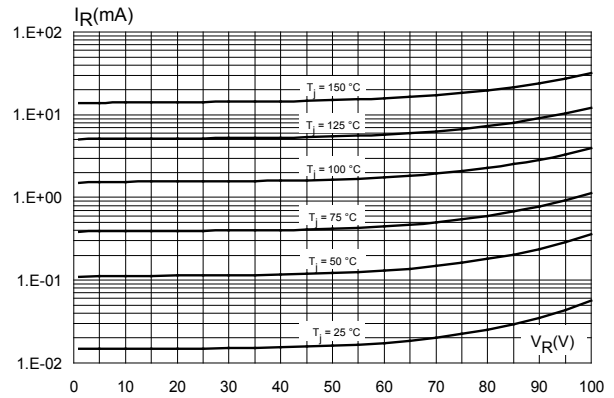

**Figure 5. Junction capacitance versus reverse voltage applied (typical values)**

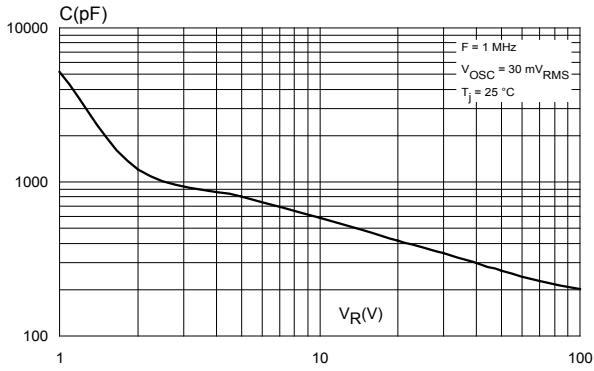

**Figure 6. Forward voltage drop versus forward current (typical values)**

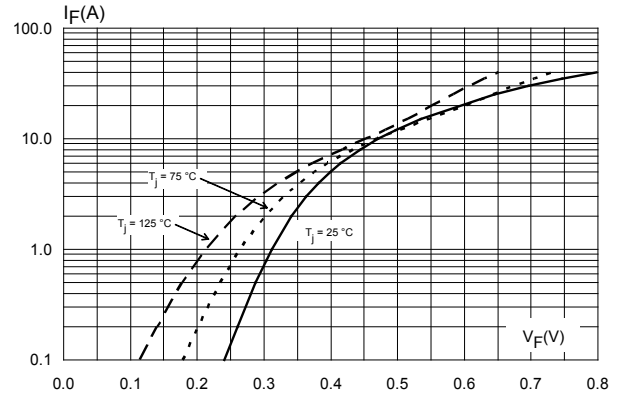

**Figure 7. Forward voltage drop versus forward current (typical values)**

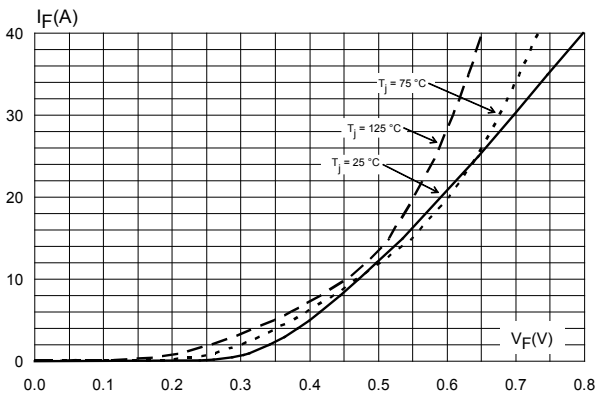

**Figure 8. Thermal resistance junction to ambient versus copper surface under tab (typical values)**

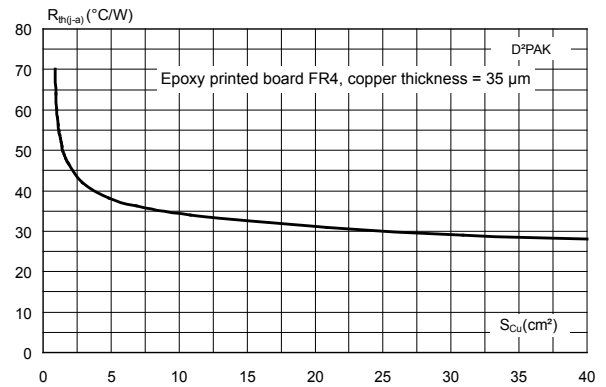

---

## 2 Package information

---

In order to meet environmental requirements, ST offers these devices in different grades of **ECOPACK®** packages, depending on their level of environmental compliance. ECOPACK® specifications, grade definitions and product status are available at: [www.st.com](http://www.st.com). ECOPACK® is an ST trademark.

### 2.1 TO-220AB package information

- Epoxy meets UL 94,V0
- Cooling method: by conduction (C)
- Recommended torque value: 0.55 N·m
- Maximum torque value: 0.60 N·m

**Figure 9. TO-220AB package outline**

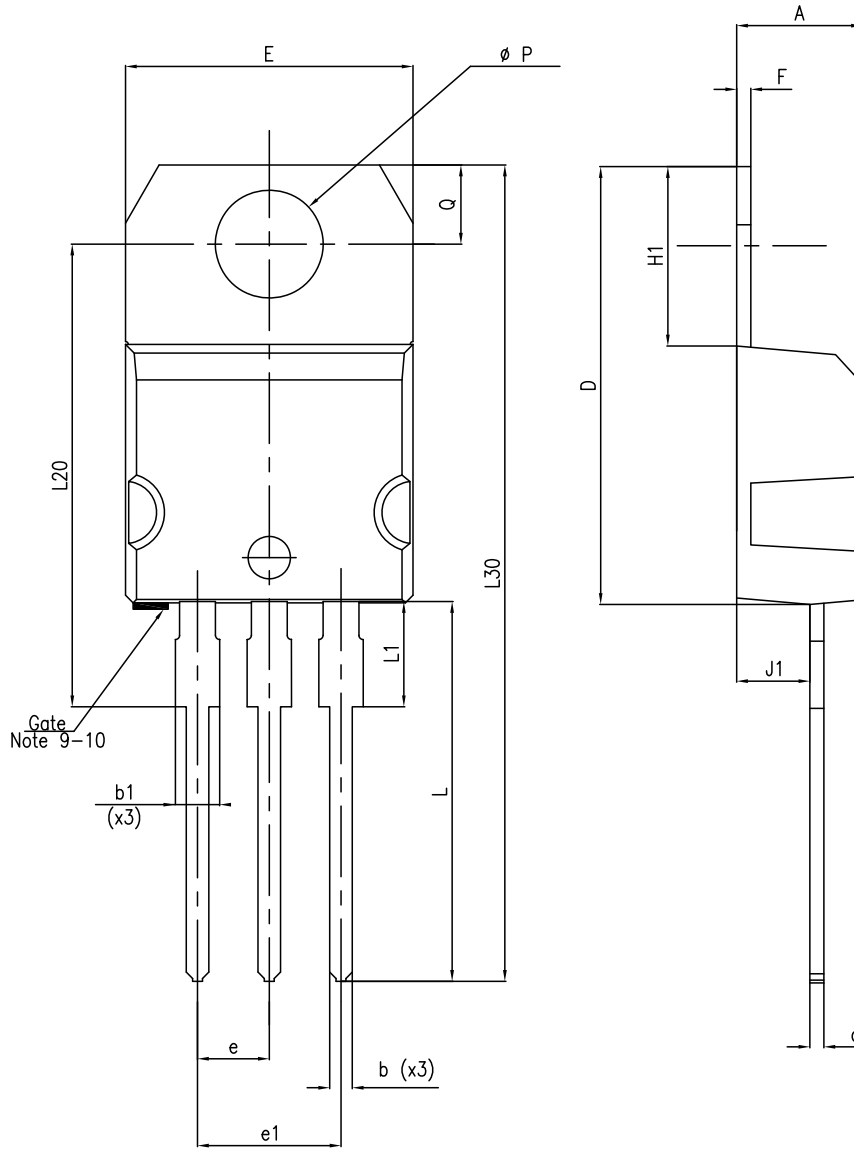

**Table 4. TO-220AB package mechanical data**

Ref.	Dimensions			
	Millimeters		Inches (for reference only)	
	Min.	Max.	Min.	Max.
A	4.40	4.60	0.173	0.181
b	0.61	0.88	0.024	0.035
b1	1.14	1.70	0.045	0.067
c	0.48	0.70	0.019	0.028
D	15.25	15.75	0.600	0.620
E	10.00	10.40	0.394	0.409
e	2.40	2.70	0.094	0.106
e1	4.95	5.15	0.195	0.203
F	0.51	0.60	0.020	0.024
H1	6.20	6.60	0.244	0.260
J1	2.40	2.72	0.094	0.107
L	13.00	14.00	0.512	0.551
L1	3.50	3.93	0.138	0.155
L20	16.40 typ.		0.646 typ.	
L30	28.90 typ.		1.138 typ.	
θP	3.75	3.85	0.148	0.152
Q	2.65	2.95	0.104	0.116

## 2.2 TO-220FPAB package information

- Epoxy meets UL 94,V0
- Cooling method: by conduction (C)
- Recommended torque value: 0.55 N·m
- Maximum torque value: 0.70 N·m

Figure 10. TO-220FPAB package outline

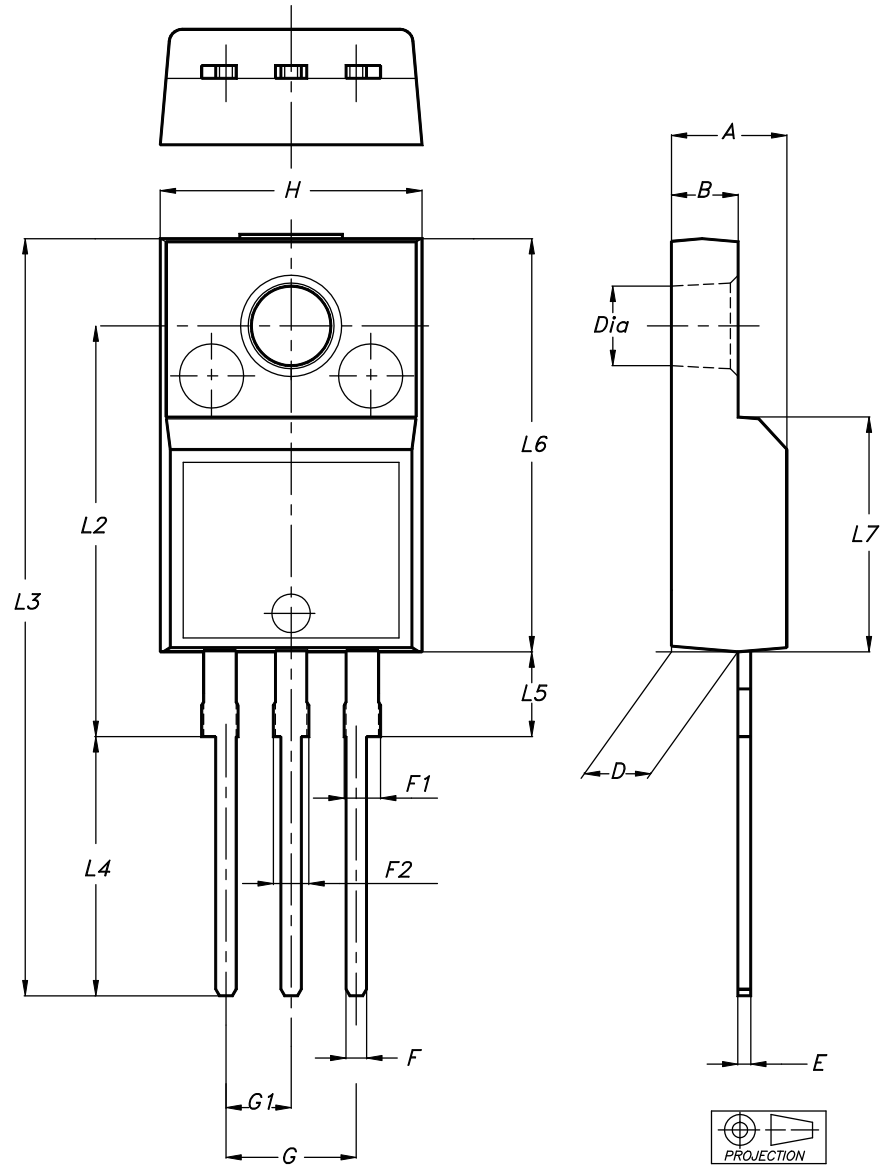



**Table 5. TO-220FPAB package mechanical data**

Ref.	Dimensions			
	Millimeters		Inches (for reference only)	
	Min.	Max.	Min.	Max.
A	4.40	4.60	0.1739	0.1818
B	2.50	2.70	0.0988	0.1067
D	2.50	2.75	0.0988	0.1087
E	0.45	0.70	0.0178	0.0277
F	0.75	1.00	0.0296	0.0395
F1	1.15	1.70	0.0455	0.0672
F2	1.15	1.70	0.0455	0.0672
G	4.95	5.20	0.1957	0.2055
G1	2.40	2.70	0.0949	0.1067
H	10.00	10.40	0.3953	0.4111
L2	16.00 typ.		0.6324 typ.	
L3	28.60	30.60	1.1304	1.2095
L4	9.80	10.60	0.3874	0.4190
L5	2.90	3.60	0.1146	0.1423
L6	15.90	16.40	0.6285	0.6482
L7	9.00	9.30	0.3557	0.3676
Dia	3.00	3.20	0.1186	0.1265

### 2.3 D<sup>2</sup>PAK package information

- Epoxy meets UL94, V0.
- Cooling method: by conduction (C)

**Figure 11. D<sup>2</sup>PAK package outline**

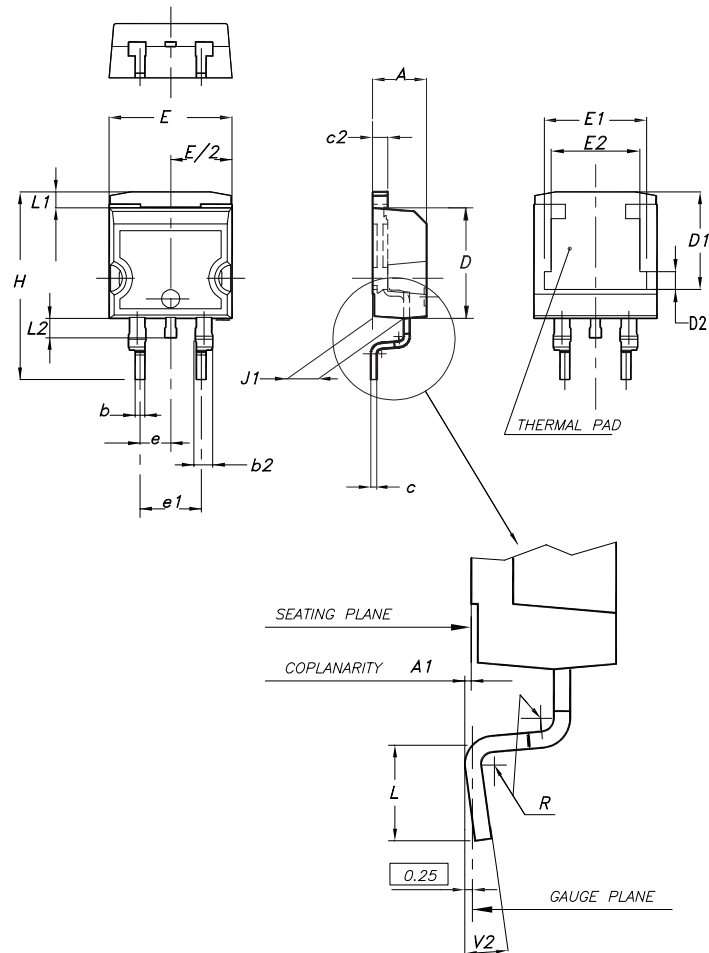

**Note:** This package drawing may slightly differ from the physical package. However, all the specified dimensions are guaranteed.

**Table 6. D<sup>2</sup>PAK package mechanical data**

Ref.	Dimensions					
	Millimeters			Inches (for reference only)		
	Min.	Typ.	Max.	Min.	Typ.	Max.
A	4.40		4.60	0.173		0.181
A1	0.03		0.23	0.001		0.009
b	0.70		0.93	0.028		0.037
b2	1.14		1.70	0.045		0.067
c	0.45		0.60	0.018		0.024
c2	1.23		1.36	0.048		0.053
D	8.95		9.35	0.352		0.368
D1	7.50	7.75	8.00	0.295	0.305	0.315
D2	1.10	1.30	1.50	0.043	0.051	0.060
E	10.00		10.40	0.394		0.409
E1	8.30	8.50	8.70	0.335	0.343	0.346
E2	6.85	7.05	7.25	0.266	0.278	0.282
e		2.54			0.100	
e1	4.88		5.28	0.190		0.205
H	15.00		15.85	0.591		0.624
J1	2.49		2.69	0.097		0.106
L	2.29		2.79	0.090		0.110
L1	1.27		1.40	0.049		0.055
L2	1.30		1.75	0.050		0.069
R		0.40			0.015	
V2	0°		8°	0°		8°

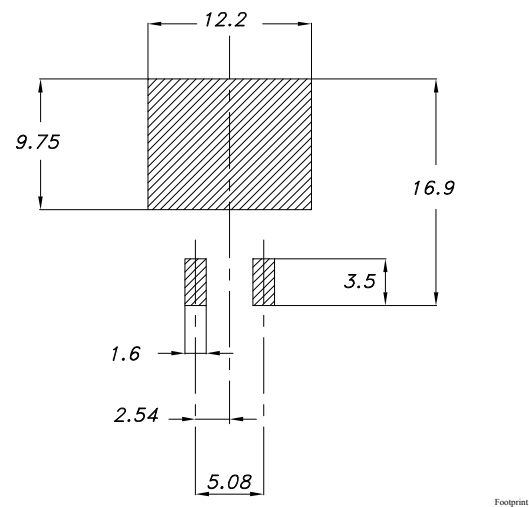
**Figure 12. D<sup>2</sup>PAK recommended footprint (dimensions are in mm)**

### 3 Ordering information

**Table 7. Ordering information**

Order code	Marking	Package	Weight	Base qty.	Delivery mode
FERD40H100STS	FD40H100STS	TO-220AB	1.38 g	50	Tube
FERD40H100SG-TR	FD40H100SG	D <sup>2</sup> PAK	1.48 g	1000	Tape and reel
FERD40H100SFP	FD40H100SFP	TO-220FPAB	1.90 g	50	Tube

## Revision history

**Table 8. Document revision history**

Date	Version	Changes
08-Apr-2016	1	Initial release.
06-Mar-2019	2	Added TO-220FPAB data information.

**IMPORTANT NOTICE – PLEASE READ CAREFULLY**

STMicroelectronics NV and its subsidiaries (“ST”) reserve the right to make changes, corrections, enhancements, modifications, and improvements to ST products and/or to this document at any time without notice. Purchasers should obtain the latest relevant information on ST products before placing orders. ST products are sold pursuant to ST’s terms and conditions of sale in place at the time of order acknowledgement.

Purchasers are solely responsible for the choice, selection, and use of ST products and ST assumes no liability for application assistance or the design of Purchasers’ products.

No license, express or implied, to any intellectual property right is granted by ST herein.

Resale of ST products with provisions different from the information set forth herein shall void any warranty granted by ST for such product.

ST and the ST logo are trademarks of ST. All other product or service names are the property of their respective owners.

Information in this document supersedes and replaces information previously supplied in any prior versions of this document.

© 2019 STMicroelectronics – All rights reserved

## X-ON Electronics

Largest Supplier of Electrical and Electronic Components

*Click to view similar products for [Rectifiers](#) category:*

*Click to view products by [STMicroelectronics](#) manufacturer:*

Other Similar products are found below :

[70HFR40](#) [RL252-TP](#) [150KR30A](#) [1N5397](#) [NTE5841](#) [NTE6038](#) [SCF5000](#) [1N4002G](#) [1N4005-TR](#) [JANS1N6640US](#) [481235F](#)  
[RRE02VS6SGTR](#) [067907F](#) [MS306](#) [70HF40](#) [T85HFL60S02](#) [US2JFL-TP](#) [A1N5404G-G](#) [CRS04\(T5L,TEMQ\)](#) [ACGRA4007-HF](#)  
[ACGRB207-HF](#) [CLH03\(TE16L,Q\)](#) [ACGRC307-HF](#) [ACEFC304-HF](#) [NTE6356](#) [NTE6359](#) [NTE6002](#) [NTE6023](#) [NTE6039](#) [NTE6077](#)  
[85HFR60](#) [40HFR60](#) [70HF120](#) [85HFR80](#) [D126A45C](#) [SCF7500](#) [D251N08B](#) [SCHJ22.5K](#) [SM100](#) [SCPA2](#) [SCH10000](#) [SDHD5K](#) [VS-](#)  
[12FL100S10](#) [ACGRA4001-HF](#) [D1821SH45T PR](#) [D1251S45T](#) [NTE5990](#) [NTE6358](#) [NTE6162](#) [NTE5850](#)