

## Fire lighter circuit

Datasheet – production data

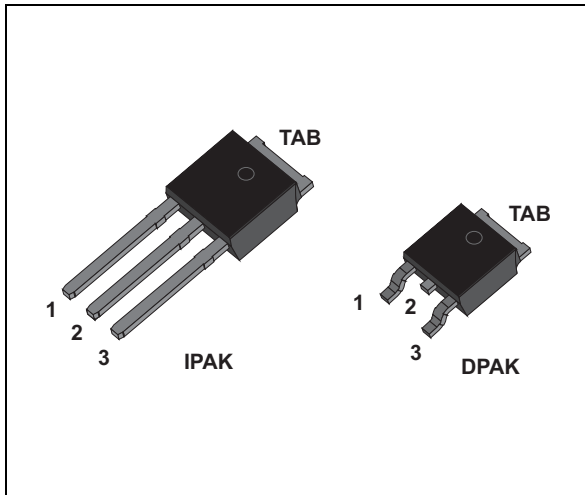

### Description

The FLC10 series has been especially developed for high power capacitance discharge operation. The main applications are gas lighters or ignitors such as cookers / gas boilers / gas hobs...

It provides a fully integrated function, with high performance and reliability levels, adapted to severe and hot temperature environment.

- **Th**: Thyristor for switching operation
- **Z**: Zener diode to set the threshold voltage
- **D**: Diode for reverse conduction
- **R**: 2 k $\Omega$  resistor

Figure 1. Functional diagram

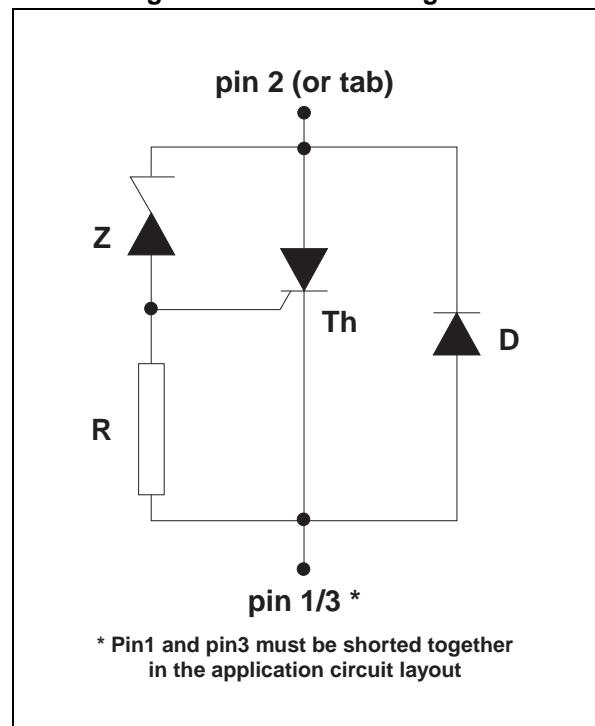

### Features

- Dedicated thyristor structure for capacitance discharge ignition operation
- High pulse current capability:
  - 240 A at  $t_p = 10 \mu s$
- Fast turn-on operation
- Designed for high ambient temperature (up to 120° C)

### Benefits

- Space saving thanks to monolithic function integration
- High reliability with planar technology

# 1 Characteristics

**Table 1. Absolute ratings (limiting values)**

Symbol	Parameter	Value	Unit
I <sub>TRM</sub>	Repetitive surge peak on state current for thyristor	240	A
	-30° C ≤ T <sub>amb</sub> ≤ 120° C		
I <sub>FRM</sub>	Repetitive surge peak on state current for diode		
	-30° C ≤ T <sub>amb</sub> ≤ 120° C		
di/dt	Critical rate of rise time on state current	200	A/μs
	-30° C ≤ T <sub>amb</sub> ≤ 120° C		
T <sub>stg</sub>	Storage junction temperature range	- 40 to + 150	° C
T <sub>j</sub>	Maximum junction temperature	+ 125	° C
T <sub>oper</sub>	Operating temperature range	- 30 to + 120	° C
T <sub>L</sub>	Maximum lead temperature for soldering during 10s	260	° C

**Table 2. Thermal resistance**

Symbol	Parameter	Value	Min.
R <sub>th(j-a)</sub>	IPAK thermal resistance junction to ambient	100	° C/W
R <sub>th(j-a)</sub>	DPAK thermal resistance junction to ambient S = 0.5 cm <sup>2</sup>	70	° C/W

**Figure 2. Electrical characteristics (definitions)**

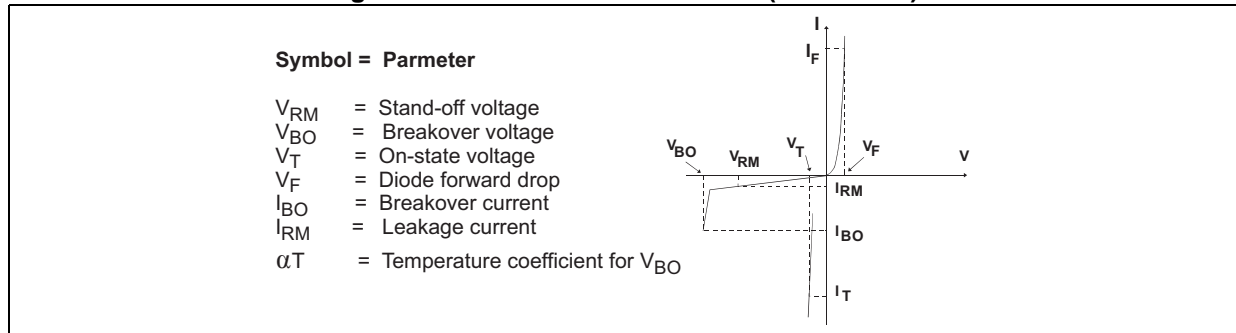

**Table 3. Electrical characteristics: diode (D) parameter**

Symbol	Test Conditions			Value	Unit	
V <sub>F</sub>	I <sub>F</sub> = 2 A	t <sub>p</sub> ≤ 500 μs	T <sub>j</sub> = 25° C	MAX	1.7	V

Table 4. Electrical characteristics: Thyristor (Th) and Zener (Z) parameters

Symbol	Test Conditions		Min.	Typ.	Max	Unit
$I_{RM}$	$V_{RM} = 200\text{ V}$	$T_j = 25^\circ\text{ C}$			1	$\mu\text{A}$
		$T_j = 125^\circ\text{ C}$			100	$\mu\text{A}$
$V_{BO}$	at $I_{BO}$	$T_j = 25^\circ\text{ C}$	200	225	250	V
$I_{BO}$	at $V_{BO}$	$T_j = 25^\circ\text{ C}$			0.5	mA
$V_T$	$I_T = 2\text{ A}, t_p \leq 500\ \mu\text{s}$	$T_j = 25^\circ\text{ C}$			1.7	V
$\alpha T$				13		$10^{-4}/^\circ\text{ C}$

Figure 3. Test current waveform

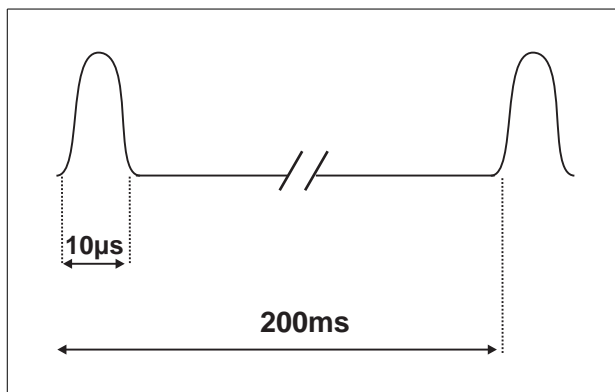

Figure 4. Relative variation of breakover current versus junction temperature

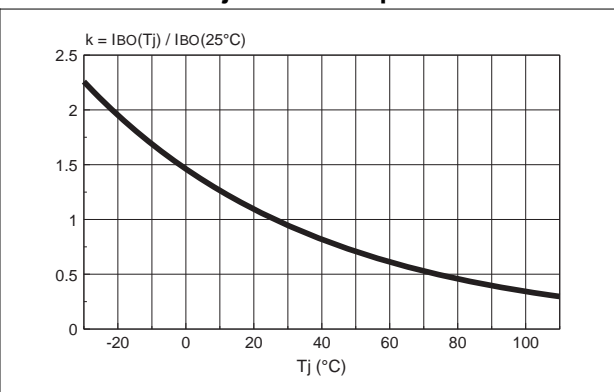
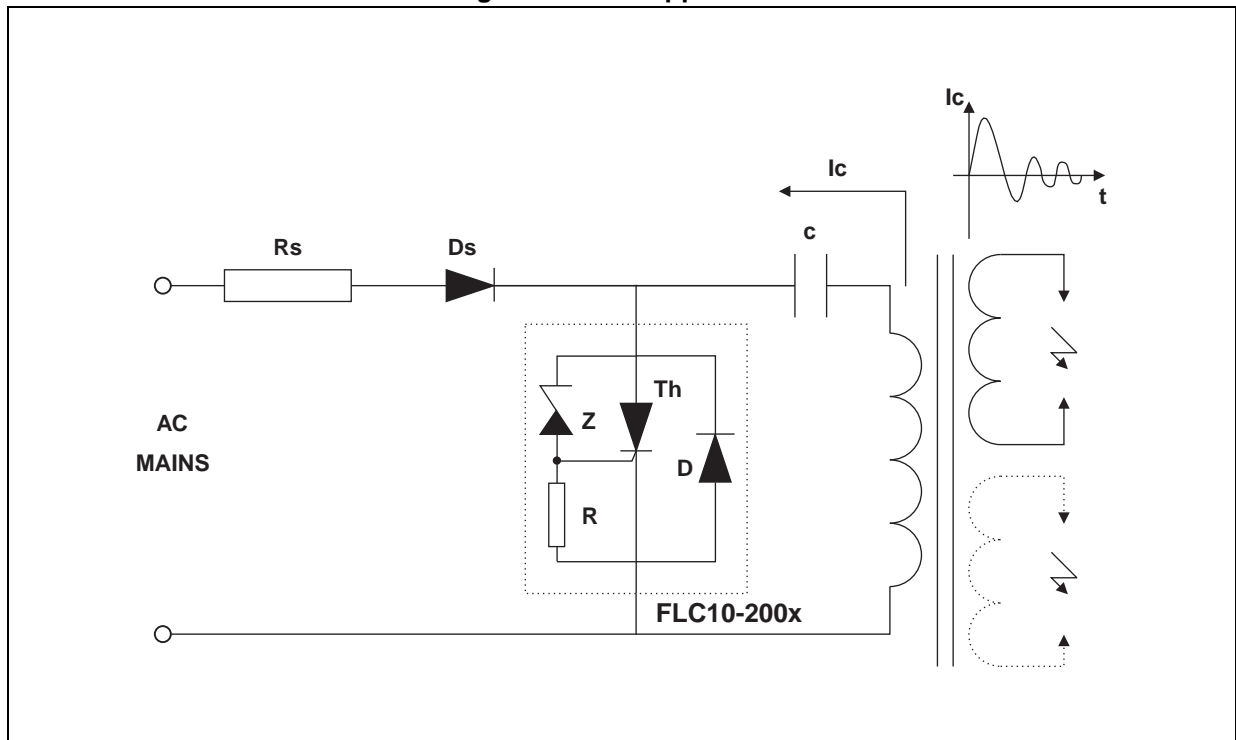

Figure 5. Basic application



The applications of the lighter using the capacitance discharge topology operate in 2 phases:

**Phase 1**

The energy coming from the mains is stored into the capacitor C. For that, the AC voltage is rectified by the diode Ds.

**Phase 2**

At the end of the phase 1, the voltage across the capacitor C reaches the avalanche threshold of the zener. Then a current flows through the gate of the thyristor Th which fires.

- The firing of the thyristor causes an alternating current to flow through the capacitor C
- The positive parts of this current flow through C, Th and the primary of the HV transformer
- The negative parts of the current flow through C, D and the primary of the HV transformer

**RS resistor calculation**

The Rs resistor allows, in addition with the capacitor C, the spark frequency to be adjusted and the current from the mains to be limited. Its value shall allow the thyristor Th to fire even in the worst case. In this case the system must fire with the lower RMS mains voltage value while the breakdown voltage and current of the FLC are at the maximum.

The maximum Rs value is equal to:

$$R_{smax} = \frac{(V_{AC \min} \cdot \sqrt{2}) - [V_{BO \max} \cdot (1 + \alpha T \cdot (T_{amb} - 25))]}{k \cdot I_{BO} (1)}$$

(1) See [Figure 4](#)

**Figure 6. Spark frequency versus RS and C**

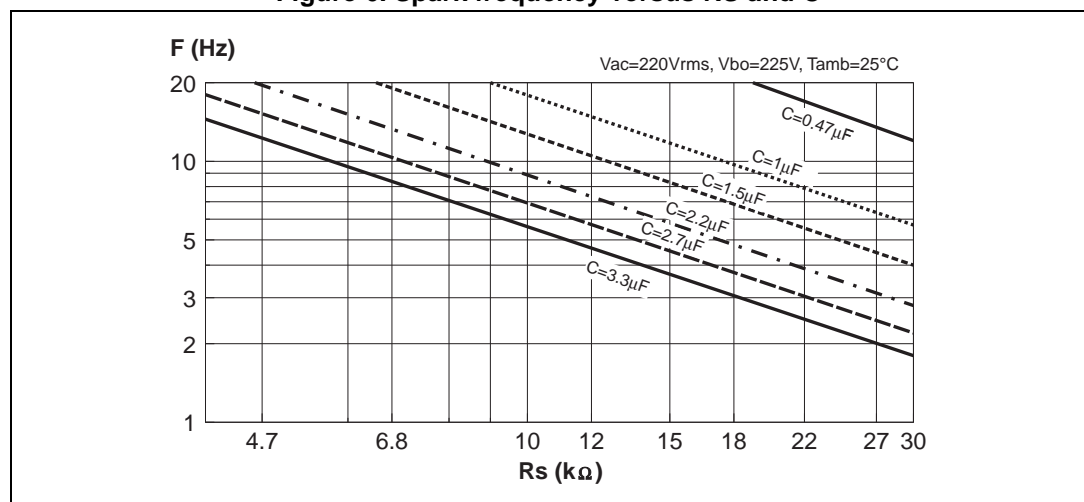

The couple Rs/C can be chosen with the previous curve. Keep in mind the Rs maximum limit for which the system would not work when the AC

mains is minimum.

The next curve on the next page shows the behavior with  $R_S = 15\text{ k}\Omega$  and  $C = 1\text{ }\mu\text{F}$ .

**Figure 7. Voltage across the capacitance with  $R_S = 15\text{ k}\Omega$ ,  $C = 1\text{ }\mu\text{F}$  and  $V_{BO} = 225\text{ V}$**

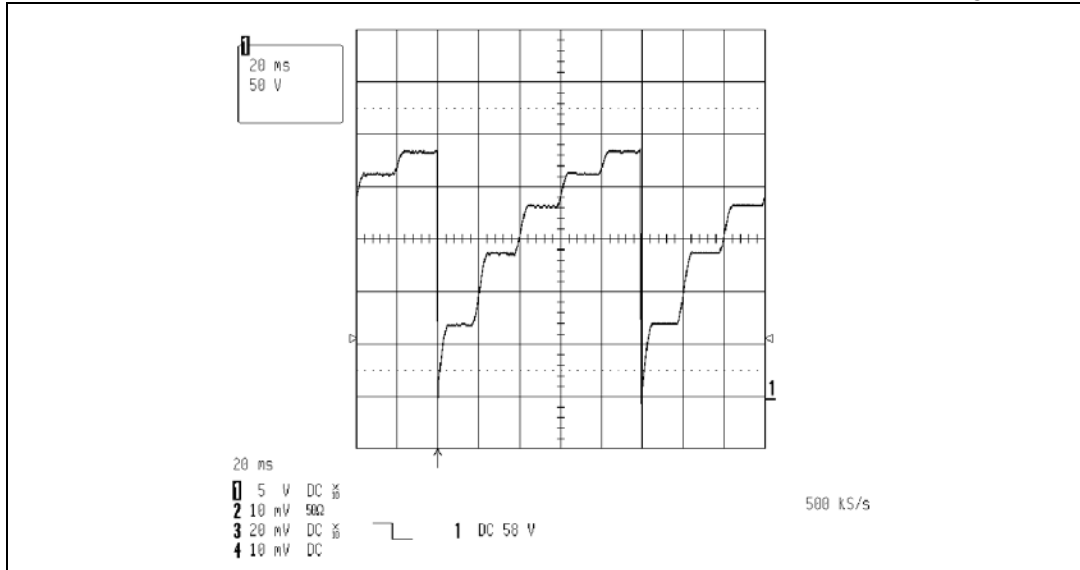

**Peak current limit**

This component is designed to withstand  $I_{TRM} = 190\text{ A}$  for a pulse duration of  $10\text{ }\mu\text{s}$  for an ambient temperature of  $120^\circ\text{C}$  in repetitive surge. The curve of peak current versus the pulse duration allows us to verify if the application is within the FLC operating limit.

**Figure 8. Peak current limit versus pulse duration**

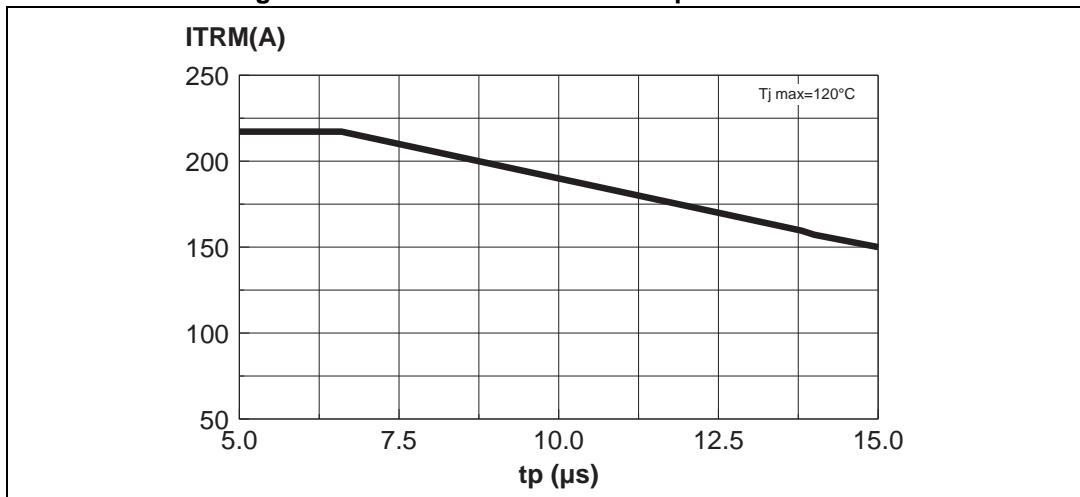

**Power losses (for  $10\text{ }\mu\text{s}$ , see [Figure 3](#))**

To evaluate the power losses, please use the following equations:

- For the thyristor:  $P = 1.18 \times I_{T(AV)} + 0.035 I_{T(RMS)}^2$
- For the diode:  $P = 0.67 \times I_{F(AV)} + 0.106 I_{F(RMS)}^2$

## 2 Package information

- Epoxy meets UL94, V0
- Lead-free package
- Recommended torque: 0.4 to 0.6 N·m

In order to meet environmental requirements, ST offers these devices in different grades of ECOPACK® packages, depending on their level of environmental compliance. ECOPACK® specifications, grade definitions and product status are available at: [www.st.com](http://www.st.com). ECOPACK® is an ST trademark.

Figure 9. DPAK dimension definitions

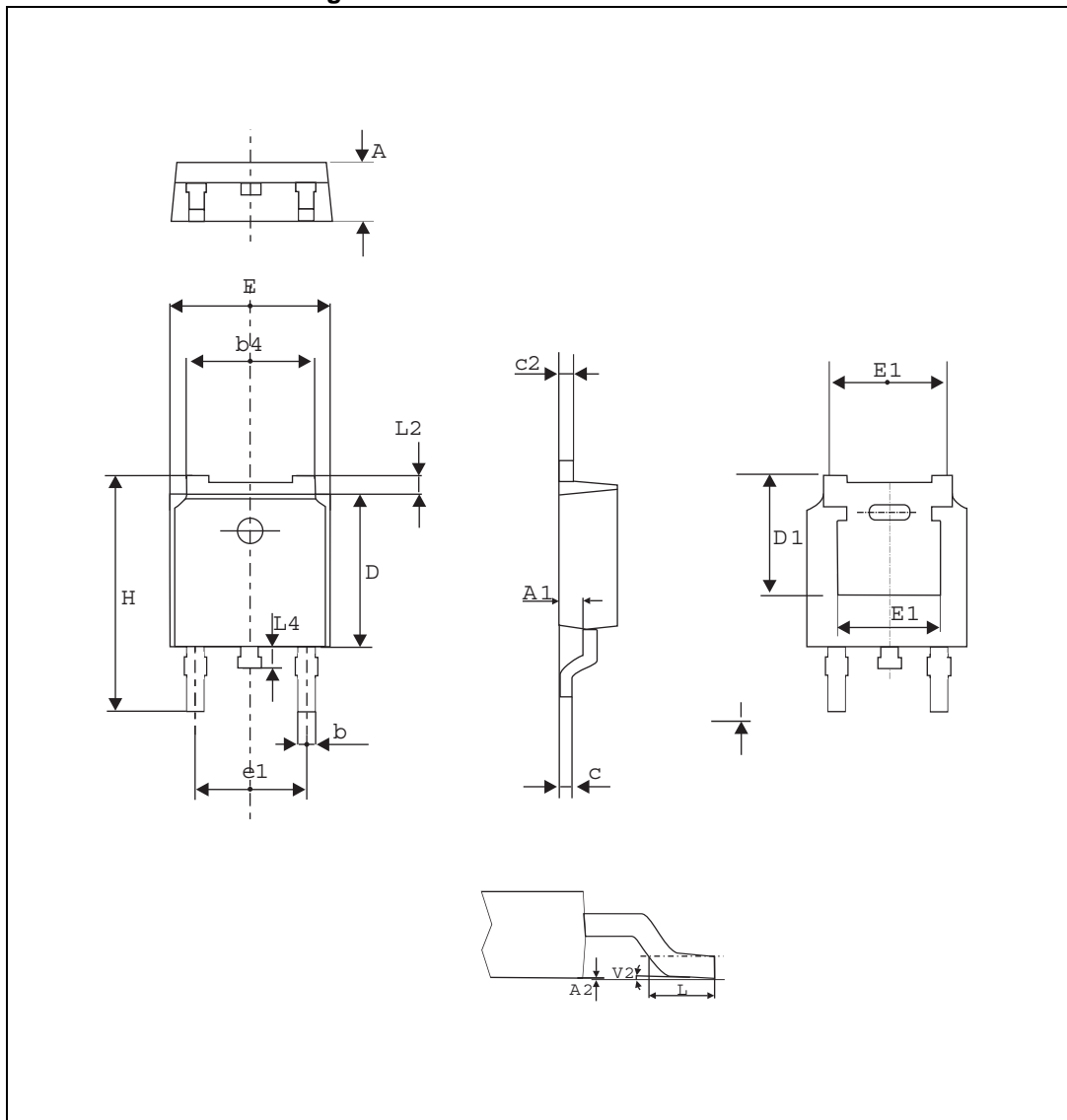

**Note:** This package drawing may slightly differ from the physical package. However, all the specified dimensions are guaranteed.

Table 5. DPAK dimension values

Ref.	Dimensions					
	Millimeters			Inches		
	Min.	Typ.	Max.	Min.	Typ.	Max.
A	2.18		2.40	0.086		0.094
A1	0.90		1.10	0.035		0.043
A2	0.03		0.23	0.001		0.009
b	0.64		0.90	0.025		0.035
b4	4.95		5.46	0.195		0.215
c	0.46		0.61	0.018		0.024
c2	0.46		0.60	0.018		0.023
D	5.97		6.22	0.235		0.244
D1	5.10			0.201		
E	6.35		6.73	0.250		0.264
E1		4.32			0.170	
e1	4.40		4.70	0.173		0.185
H	9.35		10.40	0.368		0.409
L	1.00		1.78	0.039		0.070
L2			1.27			0.05
L4	0.60		1.02	0.023		0.040
V2	0°		8°	0°		8°

Figure 10. Footprint (dimensions in mm)

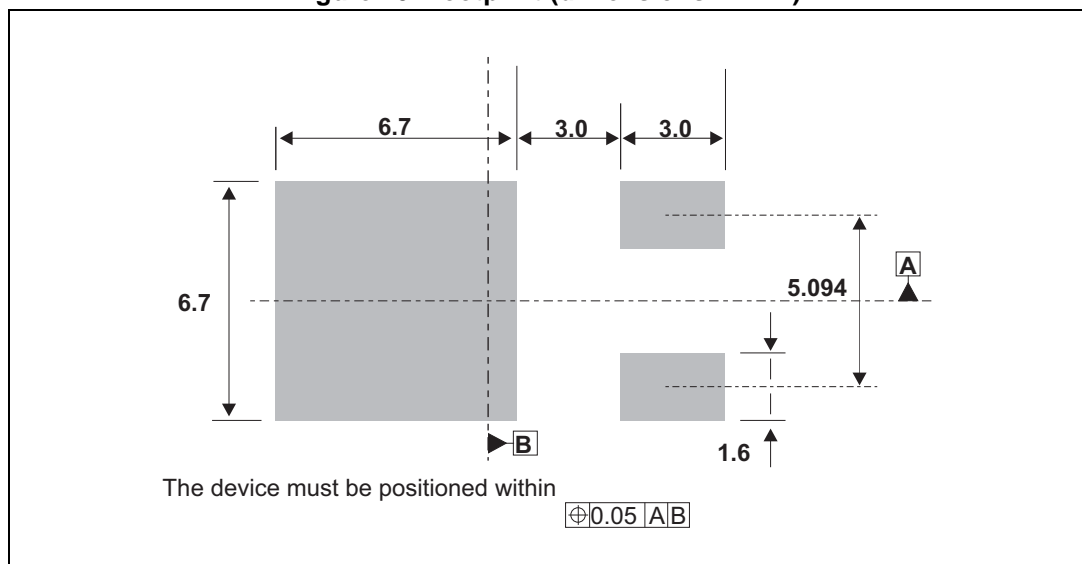
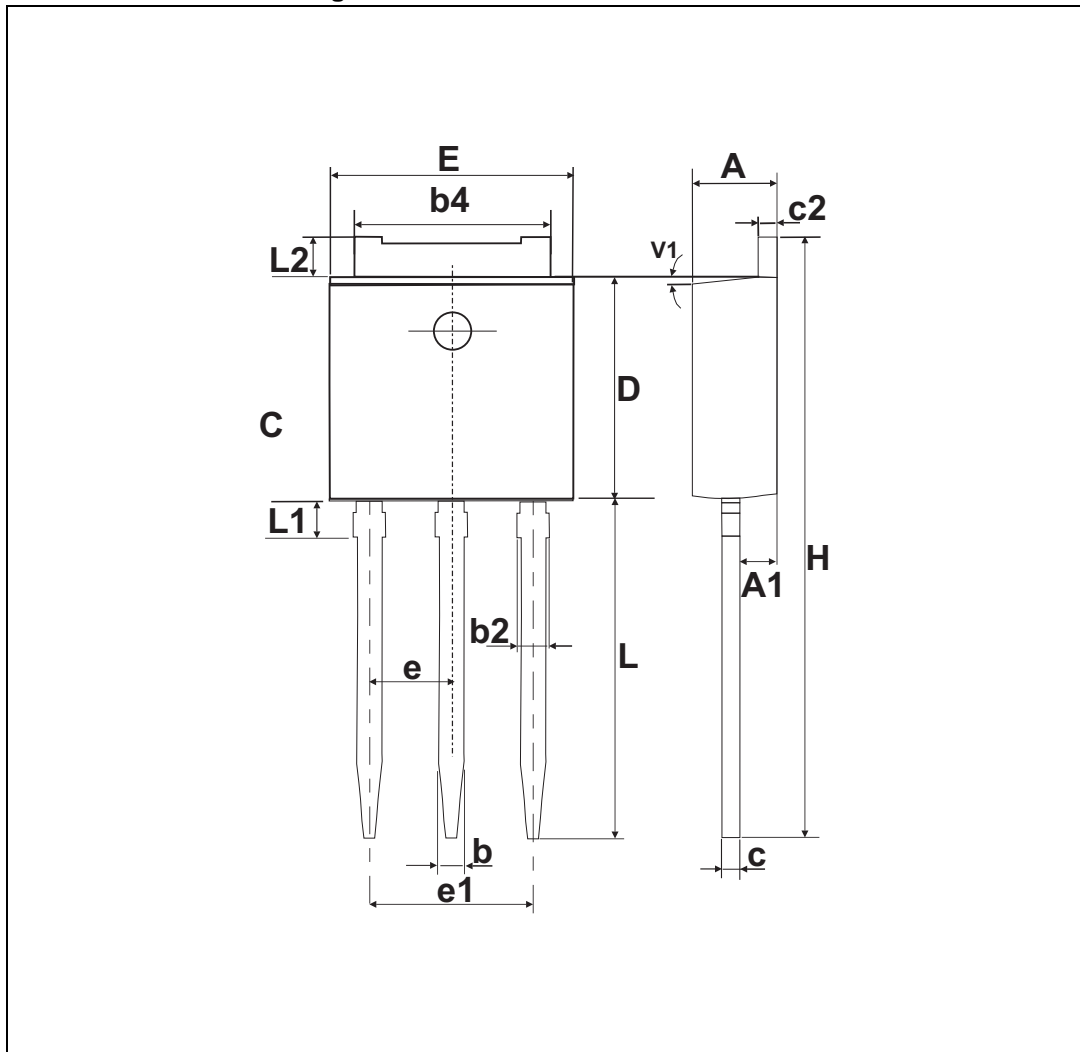

Figure 11. IPAK dimension definitions



Note: This package drawing may slightly differ from the physical package. However, all the specified dimensions are guaranteed.



Table 6. IPAK dimension values

Ref.	Dimensions					
	Millimeters			Inches		
	Min.	Typ.	Max.	Min.	Typ.	Max.
A	2.20		2.40	0.086		0.094
A1	0.90		1.10	0.035		0.043
b	0.64		0.90	0.025		0.035
b2			0.95			0.037
b4	5.20		5.43	0.204		0.213
c	0.45		0.60	0.017		0.023
c2	0.46		0.60	0.018		0.023
D	6		6.20	0.236		0.244
E	6.40		6.70	0.252		0.263
e		2.28			0.090	
e1	4.40		4.60	0.173		0.181
H		16.10			0.634	
L	9		9.60	0.354		0.377
L1	0.8		1.20	0.031		0.047
L2		0.80	1.25		0.031	0.049
V1		10°			10°	

### 3 Ordering information

Figure 12. Order information scheme

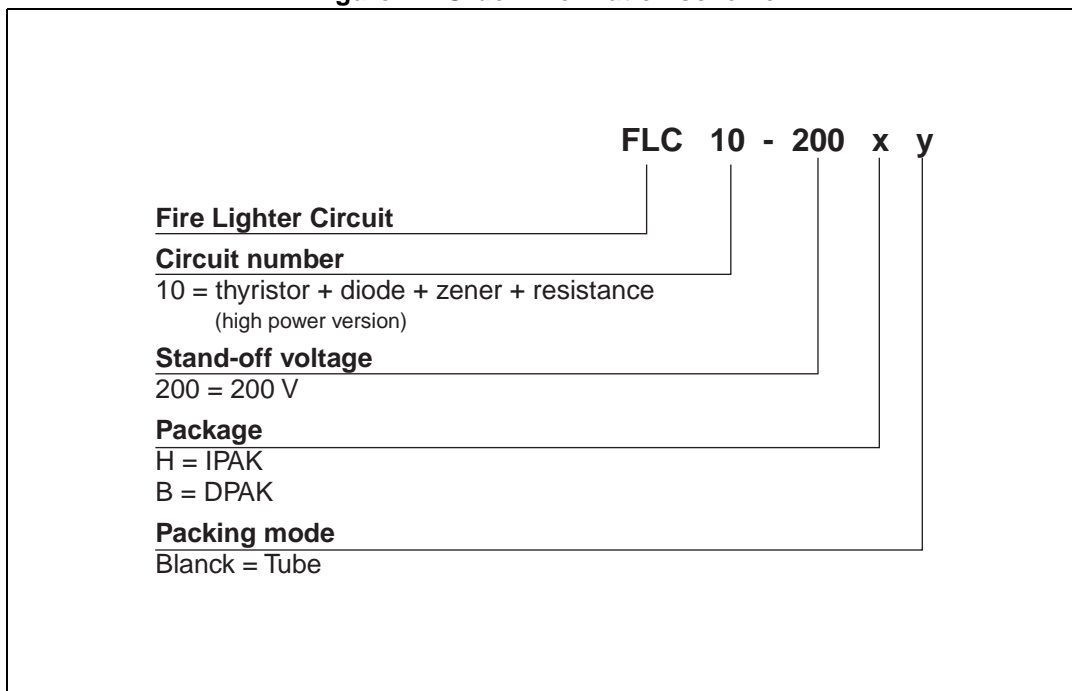

Table 7. Ordering information

Order code	Marking	Package	Weight	Base qty	Delivery mode
FLC10-200H	FLC01-200H	IPAK	0.4 g	75	Tube
FLC10-200B	FLC01-200B	DPAK	0.3 g	75	Tape and reel

### 4 Revision history

Table 8. Document revision history

Date	Revision	Changes
Sept-2001	7	First issue.
04-Jun-2014	8	Updated DPAK and IPAK package information and reformatted to current standard.

**Please Read Carefully:**

Information in this document is provided solely in connection with ST products. STMicroelectronics NV and its subsidiaries ("ST") reserve the right to make changes, corrections, modifications or improvements, to this document, and the products and services described herein at any time, without notice.

All ST products are sold pursuant to ST's terms and conditions of sale.

Purchasers are solely responsible for the choice, selection and use of the ST products and services described herein, and ST assumes no liability whatsoever relating to the choice, selection or use of the ST products and services described herein.

No license, express or implied, by estoppel or otherwise, to any intellectual property rights is granted under this document. If any part of this document refers to any third party products or services it shall not be deemed a license grant by ST for the use of such third party products or services, or any intellectual property contained therein or considered as a warranty covering the use in any manner whatsoever of such third party products or services or any intellectual property contained therein.

**UNLESS OTHERWISE SET FORTH IN ST'S TERMS AND CONDITIONS OF SALE ST DISCLAIMS ANY EXPRESS OR IMPLIED WARRANTY WITH RESPECT TO THE USE AND/OR SALE OF ST PRODUCTS INCLUDING WITHOUT LIMITATION IMPLIED WARRANTIES OF MERCHANTABILITY, FITNESS FOR A PARTICULAR PURPOSE (AND THEIR EQUIVALENTS UNDER THE LAWS OF ANY JURISDICTION), OR INFRINGEMENT OF ANY PATENT, COPYRIGHT OR OTHER INTELLECTUAL PROPERTY RIGHT.**

**ST PRODUCTS ARE NOT DESIGNED OR AUTHORIZED FOR USE IN: (A) SAFETY CRITICAL APPLICATIONS SUCH AS LIFE SUPPORTING, ACTIVE IMPLANTED DEVICES OR SYSTEMS WITH PRODUCT FUNCTIONAL SAFETY REQUIREMENTS; (B) AERONAUTIC APPLICATIONS; (C) AUTOMOTIVE APPLICATIONS OR ENVIRONMENTS, AND/OR (D) AEROSPACE APPLICATIONS OR ENVIRONMENTS. WHERE ST PRODUCTS ARE NOT DESIGNED FOR SUCH USE, THE PURCHASER SHALL USE PRODUCTS AT PURCHASER'S SOLE RISK, EVEN IF ST HAS BEEN INFORMED IN WRITING OF SUCH USAGE, UNLESS A PRODUCT IS EXPRESSLY DESIGNATED BY ST AS BEING INTENDED FOR "AUTOMOTIVE, AUTOMOTIVE SAFETY OR MEDICAL" INDUSTRY DOMAINS ACCORDING TO ST PRODUCT DESIGN SPECIFICATIONS. PRODUCTS FORMALLY ESCC, QML OR JAN QUALIFIED ARE DEEMED SUITABLE FOR USE IN AEROSPACE BY THE CORRESPONDING GOVERNMENTAL AGENCY.**

Resale of ST products with provisions different from the statements and/or technical features set forth in this document shall immediately void any warranty granted by ST for the ST product or service described herein and shall not create or extend in any manner whatsoever, any liability of ST.

ST and the ST logo are trademarks or registered trademarks of ST in various countries.

Information in this document supersedes and replaces all information previously supplied.

The ST logo is a registered trademark of STMicroelectronics. All other names are the property of their respective owners.

© 2014 STMicroelectronics - All rights reserved

STMicroelectronics group of companies

Australia - Belgium - Brazil - Canada - China - Czech Republic - Finland - France - Germany - Hong Kong - India - Israel - Italy - Japan - Malaysia - Malta - Morocco - Philippines - Singapore - Spain - Sweden - Switzerland - United Kingdom - United States of America

[www.st.com](http://www.st.com)

## X-ON Electronics

Largest Supplier of Electrical and Electronic Components

*Click to view similar products for [SCRs](#) category:*

*Click to view products by [STMicroelectronics](#) manufacturer:*

Other Similar products are found below :

[NTE5428](#) [T1500N16TOF VT](#) [T880N16TOF](#) [TT162N16KOF-A](#) [TT162N16KOF-K](#) [TT330N16AOF](#) [VS-22RIA20](#) [VS-2N685](#) [057219R](#)  
[T1190N16TOF VT](#) [T1220N22TOF VT](#) [T201N70TOH](#) [T700N22TOF](#) [T830N18TOF](#) [TT250N12KOF-K](#) [VS-110RKI40](#) [NTE5427](#) [NTE5442](#)  
[T2160N28TOF VT](#) [TT251N16KOF-K](#) [VS-22RIA100](#) [VS-16RIA40](#) [TD250N16KOF-A](#) [VS-ST110S16P0](#) [T930N36TOF VT](#) [T2160N24TOF](#)  
[VT](#) [T1190N18TOF VT](#) [T1590N28TOF VT](#) [2N1776A](#) [T590N14TOF](#) [NTE5375](#) [NTE5460](#) [NTE5481](#) [NTE5512](#) [NTE5514](#) [NTE5518](#)  
[NTE5519](#) [NTE5529](#) [NTE5553](#) [NTE5555](#) [NTE5557](#) [NTE5567](#) [NTE5570](#) [NTE5572](#) [NTE5574](#) [NTE5576](#) [NTE5578](#) [NTE5579](#) [NTE5589](#)  
[NTE5592](#)