



# HCF4049UB

## HEX BUFFER/CONVERTER (INVERTING)

- PROPAGATION DELAY TIME:  
 $t_{PD} = 40\text{ns}$  (TYP.) at  $V_{DD} = 10\text{V}$   $C_L = 50\text{pF}$
- HIGH TO LOW LEVEL LOGIC CONVERSION
- HIGH "SINK" AND "SOURCE" CURRENT CAPABILITY
- QUIESCENT CURRENT SPECIFIED UP TO 20V
- 5V, 10V AND 15V PARAMETRIC RATINGS
- INPUT LEAKAGE CURRENT  
 $I_l = 100\text{nA}$  (MAX) AT  $V_{DD} = 18\text{V}$   $T_A = 25^\circ\text{C}$
- 100% TESTED FOR QUIESCENT CURRENT

### DESCRIPTION

The HCF4049UB is a monolithic integrated circuit fabricated in Metal Oxide Semiconductor technology available in DIP and SOP packages. It is an inverting Hex Buffer/Converter and feature logic level conversions using only one supply voltage ( $V_{DD}$ ).

The input high level signal ( $V_{IH}$ ) can exceed the  $V_{DD}$  supply voltage when these devices are used

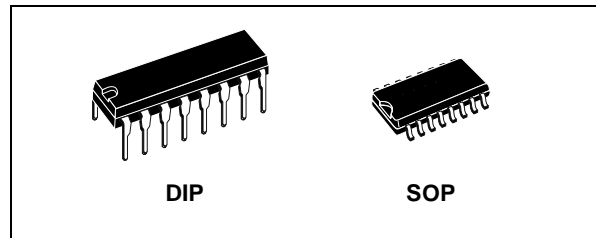

### ORDER CODES

PACKAGE	TUBE	T & R
DIP	HCF4049UBEY	
SOP	HCF4049UBM1	HCF4049UM013TR

for logic level conversions. This device is intended for use as CMOS to DTL/TTL converters and can drive directly two DTL/TTL loads ( $V_{DD} = 5\text{V}$ ,  $V_{OL} \leq 0.4\text{V}$  and  $I_{OL} \leq 3.2\text{mA}$ ).

### PIN CONNECTION

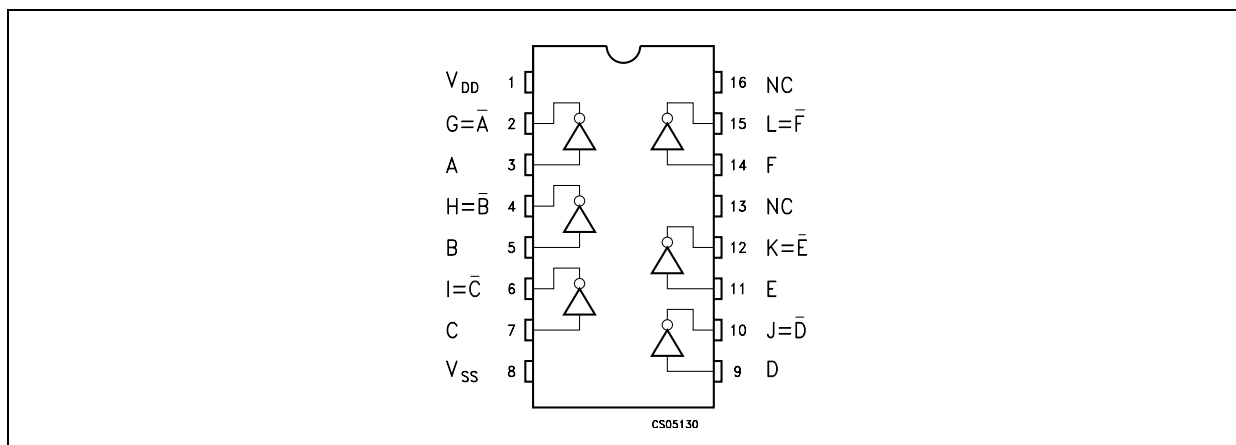

**INPUT EQUIVALENT CIRCUIT**

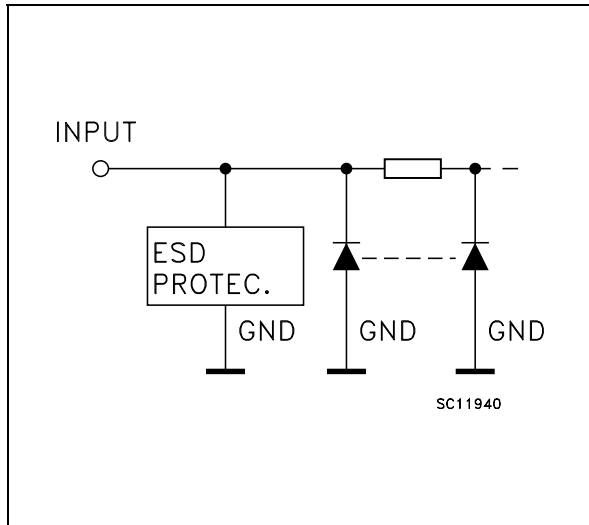

**PIN DESCRIPTION**

PIN N°	SYMBOL	NAME AND FUNCTION
3, 5, 7, 9, 11, 14	A, B, C, D, E, F	Data Inputs
2, 4, 6, 10, 12, 15	G, H, I, J, K, L	Data Outputs
13, 16	NC	Not Connected
8	V <sub>SS</sub>	Negative Supply Voltage
1	V <sub>DD</sub>	Positive Supply Voltage

**TRUTH TABLE**

INPUTS	OUTPUTS
A, B, C, D, E, F	G, H, I, J, K, L
L	H
H	L

**ABSOLUTE MAXIMUM RATINGS**

Symbol	Parameter	Value	Unit
V <sub>DD</sub>	Supply Voltage	-0.5 to +22	V
V <sub>I</sub>	DC Input Voltage	-0.5 to +18	V
I <sub>I</sub>	DC Input Current	± 10	mA
P <sub>D</sub>	Power Dissipation per Package	200	mW
	Power Dissipation per Output Transistor	100	mW
T <sub>op</sub>	Operating Temperature	-55 to +125	°C
T <sub>stg</sub>	Storage Temperature	-65 to +150	°C

Absolute Maximum Ratings are those values beyond which damage to the device may occur. Functional operation under these conditions is not implied.  
All voltage values are referred to V<sub>SS</sub> pin voltage.

**RECOMMENDED OPERATING CONDITIONS**

Symbol	Parameter	Value	Unit
V <sub>DD</sub>	Supply Voltage	3 to 20	V
V <sub>I</sub>	Input Voltage	-0.5 to 15V	V
T <sub>op</sub>	Operating Temperature	-55 to 125	°C

## DC SPECIFICATIONS

Symbol	Parameter	Test Condition				Value						Unit	
		V <sub>I</sub> (V)	V <sub>O</sub> (V)	I <sub>OL</sub>   ( $\mu$ A)	V <sub>DD</sub> (V)	T <sub>A</sub> = 25°C			-40 to 85°C		-55 to 125°C		
						Min.	Typ.	Max.	Min.	Max.	Min.		Max.
I <sub>L</sub>	Quiescent Current	0/5			5		0.02	1		30		30	$\mu$ A
		0/10			10		0.02	2		60		60	
		0/15			15		0.02	4		120		120	
		0/20			20		0.04	20		600		600	
V <sub>OH</sub>	High Level Output Voltage	0/5		<1	5	4.95			4.95		4.95		V
		0/10		<1	10	9.95			9.95		9.95		
		0/15		<1	15	14.95			14.95		14.95		
V <sub>OL</sub>	Low Level Output Voltage	5/0		<1	5		0.05			0.05		0.05	V
		10/0		<1	10		0.05			0.05		0.05	
		15/0		<1	15		0.05			0.05		0.05	
V <sub>IH</sub>	High Level Input Voltage		0.5/4.5	<1	5	4			4		4		V
			1/9	<1	10	8			8		8		
			1.5/13.5	<1	15	12			12		12		
V <sub>IL</sub>	Low Level Input Voltage		4.5/0.5	<1	5			1		1		1	V
			9/1	<1	10			2		2		2	
			13.5/1.5	<1	15			3		3		3	
I <sub>OH</sub>	Output Drive Current	0/5	2.5	<1	5	-1.25	-6.4		-0.42		-0.42		mA
		0/5	4.6	<1	5	-0.51	-1.6		-0.38		-0.38		
		0/10	9.5	<1	10	-1.25	-3.6		-1		-1		
		0/15	13.5	<1	15	-3.75	-12		-3		-3		
I <sub>OL</sub>	Output Sink Current	0/5	0.4	<1	5	3.2	6.4		2.6		2.6		mA
		0/10	0.5	<1	10	8	16		6.6		6.6		
		0/15	1.5	<1	15	24	48		19		19		
I <sub>I</sub>	Input Leakage Current	0/18	Any Input		18		$\pm 10^{-5}$	$\pm 0.1$		$\pm 1$		$\pm 1$	$\mu$ A
C <sub>I</sub>	Input Capacitance		Any Input				5	7.5					pF

The Noise Margin for both "1" and "0" level is: 1V min. with V<sub>DD</sub>=5V, 2V min. with V<sub>DD</sub>=10V, 2.5V min. with V<sub>DD</sub>=15V

# HCF4049UB

## DYNAMIC ELECTRICAL CHARACTERISTICS ( $T_{amb} = 25^{\circ}\text{C}$ , $C_L = 50\text{pF}$ , $R_L = 200\text{K}\Omega$ , $t_r = t_f = 20\text{ ns}$ )

Symbol	Parameter	Test Condition			Value (*)			Unit
		$V_{DD}$ (V)	$V_I$ (V)		Min.	Typ.	Max.	
$t_{TLH}$	Output Transition Time	5	5			80	160	ns
		10	10			40	80	
		15	15			30	60	
$t_{THL}$	Output Transition Time	5	5			30	60	ns
		10	10			20	40	
		15	15			15	30	
$t_{PLH}$	Propagation Delay Time	5	5			60	120	ns
		10	10			32	65	
		5	10			45	90	
		15	15			25	50	
		5	15			45	90	
$t_{PHL}$	Propagation Delay Time	5	5			32	65	ns
		10	10			20	40	
		5	10			15	30	
		15	15			15	30	
		5	15			10	20	

(\*) Typical temperature coefficient for all  $V_{DD}$  value is 0.3%/°C.

### TEST CIRCUIT

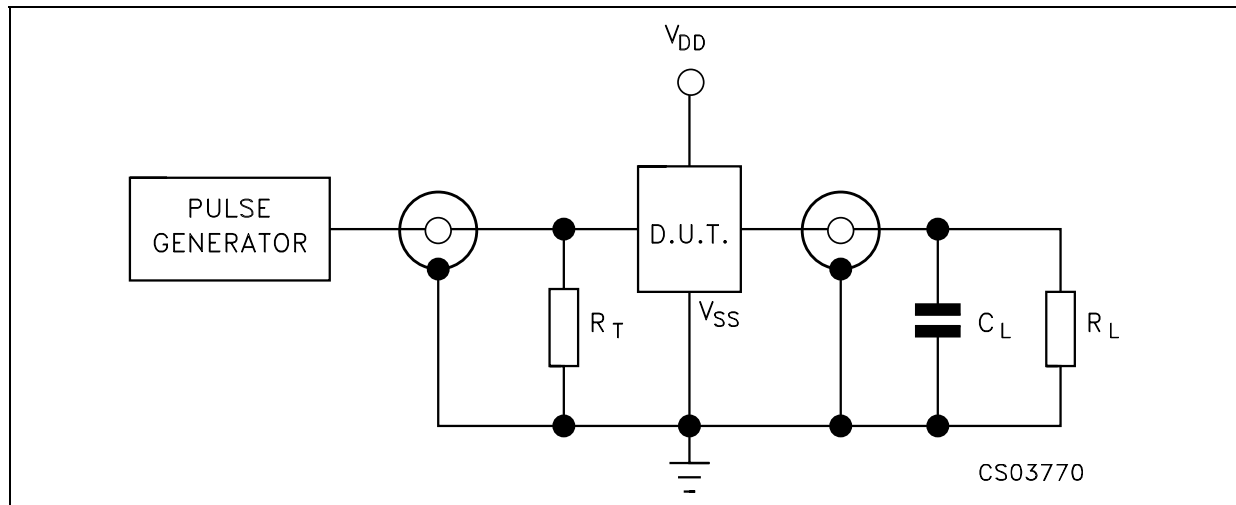

$C_L = 50\text{pF}$  or equivalent (includes jig and probe capacitance)

$R_L = 200\text{K}\Omega$

$R_T = Z_{OUT}$  of pulse generator (typically  $50\Omega$ )

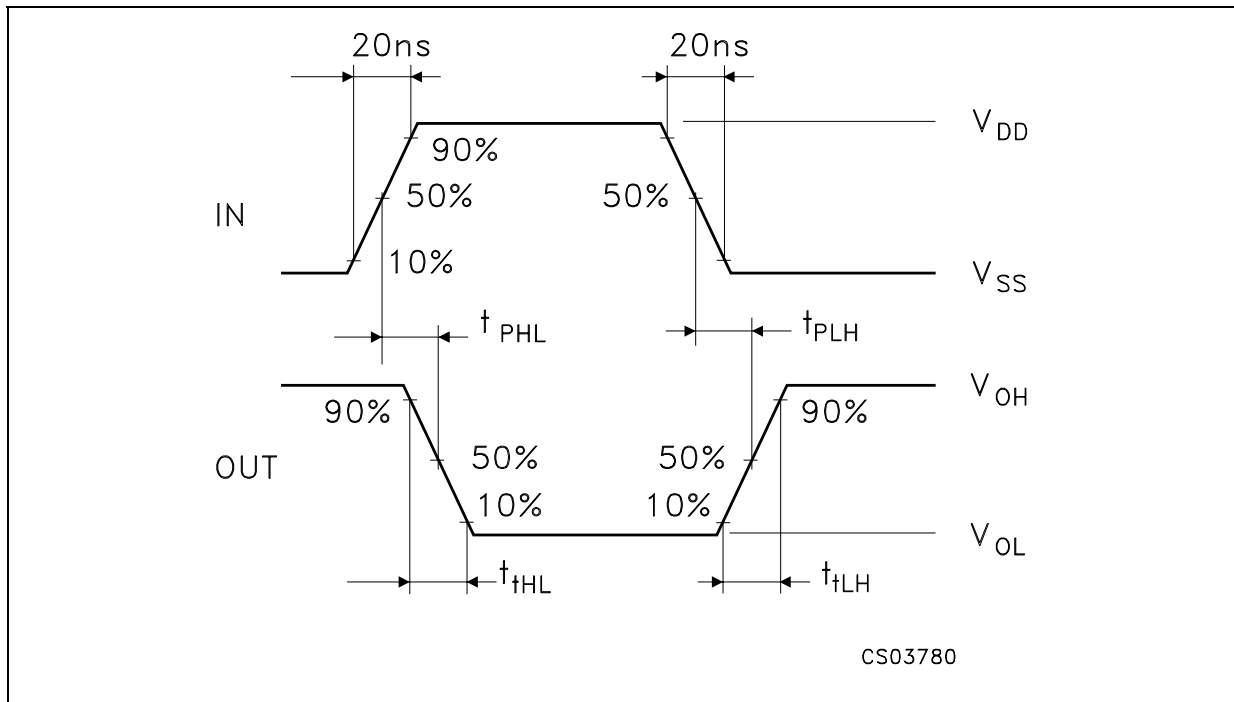
WAVEFORM: PROPAGATION DELAY TIMES ( $f=1\text{MHz}$ ; 50% duty cycle)

**Plastic DIP-16 (0.25) MECHANICAL DATA**

DIM.	mm.			inch		
	MIN.	TYP	MAX.	MIN.	TYP.	MAX.
a1	0.51			0.020		
B	0.77		1.65	0.030		0.065
b		0.5			0.020	
b1		0.25			0.010	
D			20			0.787
E		8.5			0.335	
e		2.54			0.100	
e3		17.78			0.700	
F			7.1			0.280
I			5.1			0.201
L		3.3			0.130	
Z			1.27			0.050

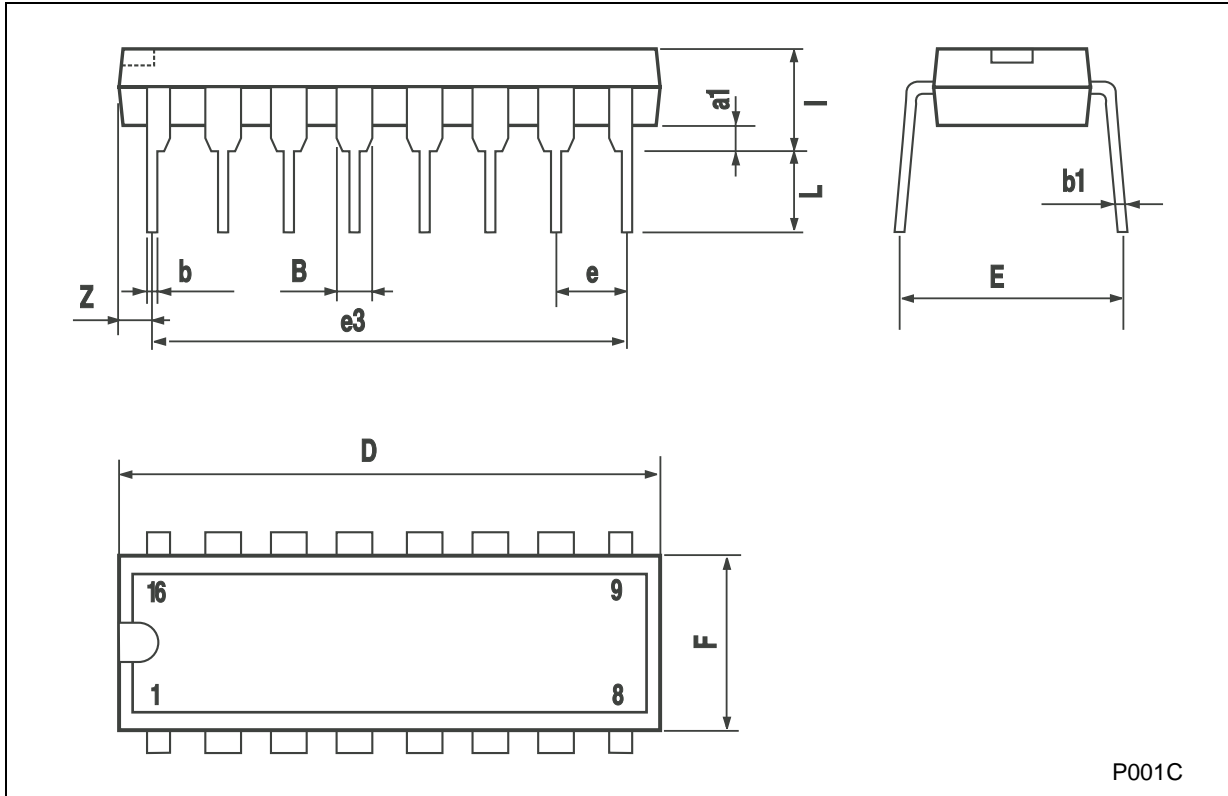

## SO-16 MECHANICAL DATA

DIM.	mm.			inch		
	MIN.	TYP.	MAX.	MIN.	TYP.	MAX.
A			1.75			0.068
a1	0.1		0.2	0.004		0.008
a2			1.65			0.064
b	0.35		0.46	0.013		0.018
b1	0.19		0.25	0.007		0.010
C		0.5			0.019	
c1	45° (typ.)					
D	9.8		10	0.385		0.393
E	5.8		6.2	0.228		0.244
e		1.27			0.050	
e3		8.89			0.350	
F	3.8		4.0	0.149		0.157
G	4.6		5.3	0.181		0.208
L	0.5		1.27	0.019		0.050
M			0.62			0.024
S	8			° (max.)		

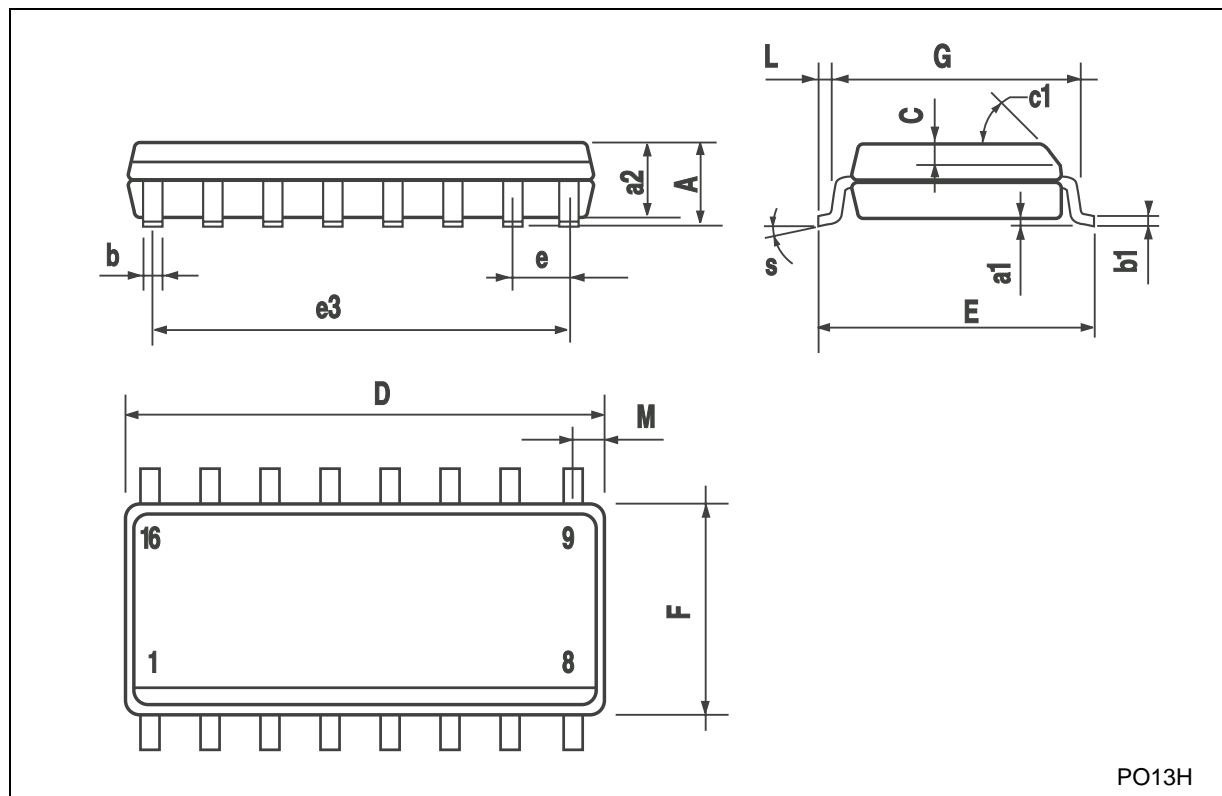

PO13H

**Tape & Reel SO-16 MECHANICAL DATA**

DIM.	mm.			inch		
	MIN.	TYP	MAX.	MIN.	TYP.	MAX.
A			330			12.992
C	12.8		13.2	0.504		0.519
D	20.2			0.795		
N	60			2.362		
T			22.4			0.882
Ao	6.45		6.65	0.254		0.262
Bo	10.3		10.5	0.406		0.414
Ko	2.1		2.3	0.082		0.090
Po	3.9		4.1	0.153		0.161
P	7.9		8.1	0.311		0.319

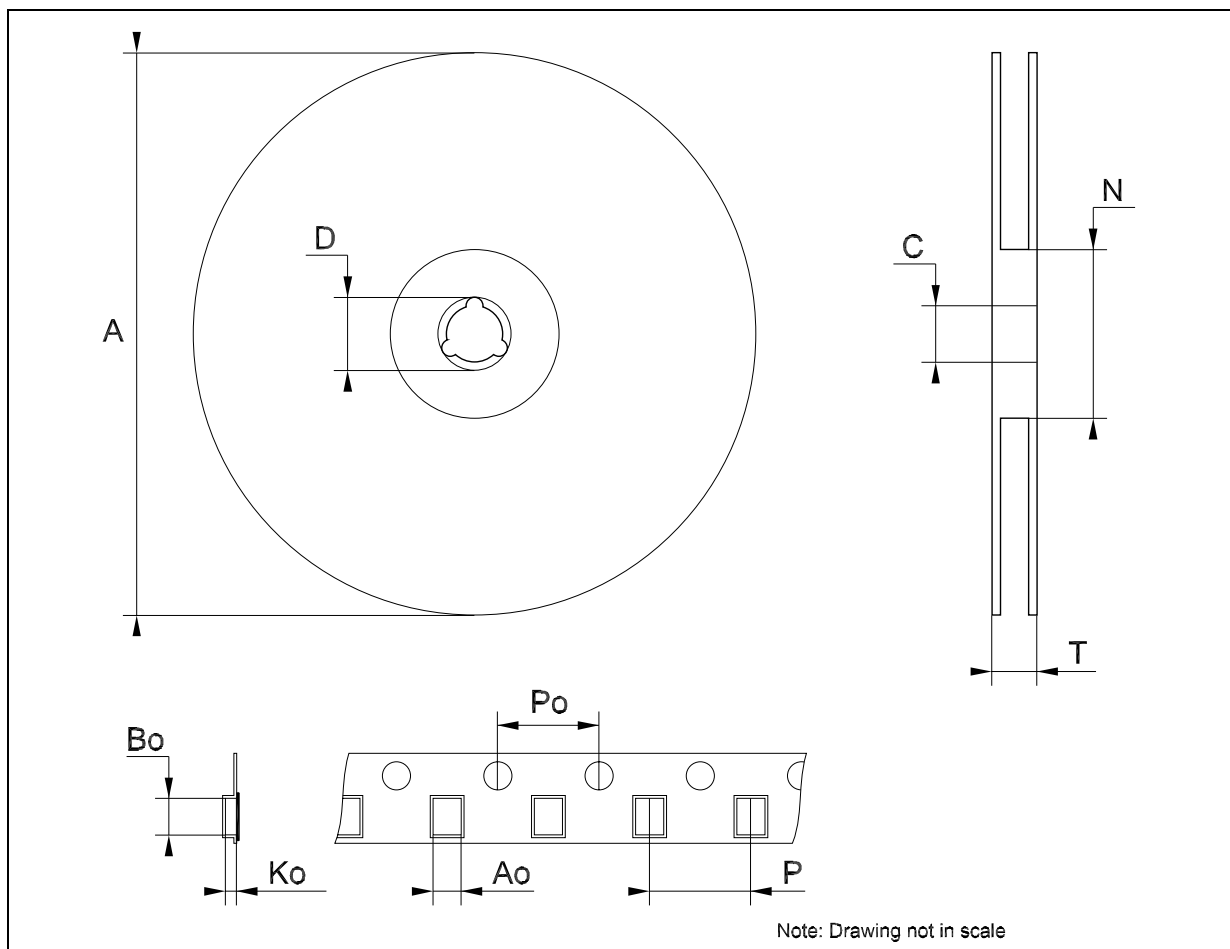



Information furnished is believed to be accurate and reliable. However, STMicroelectronics assumes no responsibility for the consequences of use of such information nor for any infringement of patents or other rights of third parties which may result from its use. No license is granted by implication or otherwise under any patent or patent rights of STMicroelectronics. Specifications mentioned in this publication are subject to change without notice. This publication supersedes and replaces all information previously supplied. STMicroelectronics products are not authorized for use as critical components in life support devices or systems without express written approval of STMicroelectronics.

The ST logo is a registered trademark of STMicroelectronics  
All other names are the property of their respective owners

© 2004 STMicroelectronics - All Rights Reserved  
STMicroelectronics GROUP OF COMPANIES

Australia - Belgium - Brazil - Canada - China - Czech Republic - Finland - France - Germany - Hong Kong - India - Israel - Italy - Japan -  
Malaysia - Malta - Morocco - Singapore - Spain - Sweden - Switzerland - United Kingdom - United States.

<http://www.st.com>

## X-ON Electronics

Largest Supplier of Electrical and Electronic Components

*Click to view similar products for [Buffers & Line Drivers](#) category:*

*Click to view products by [STMicroelectronics](#) manufacturer:*

Other Similar products are found below :

[5962-9217601MSA](#) [634810D](#) [HEF4043BP](#) [NL17SG125DFT2G](#) [NL17SZ126P5T5G](#) [NLU1GT126CMUTCG](#) [NLU3G16AMX1TCG](#)  
[NLV27WZ125USG](#) [MC74HCT365ADTR2G](#) [BCM6306KMLG](#) [54FCT240CTDB](#) [Le87401NQC](#) [Le87402MQC](#) [028192B](#) [042140C](#)  
[051117G](#) [070519XB](#) [065312DB](#) [091056E](#) [098456D](#) [NL17SG07DFT2G](#) [NL17SG17DFT2G](#) [NL17SG34DFT2G](#) [NL17SZ07P5T5G](#)  
[NL17SZ125P5T5G](#) [NLU1GT126AMUTCG](#) [NLV27WZ16DFT2G](#) [5962-8982101PA](#) [5962-9052201PA](#) [74LVC07ADR2G](#)  
[MC74VHC1G125DFT1G](#) [NL17SH17P5T5G](#) [NL17SZ125CMUTCG](#) [NLV17SZ07DFT2G](#) [NLV37WZ17USG](#) [NLVHCT244ADTR2G](#)  
[NC7WZ17FHX](#) [74HCT126T14-13](#) [NL17SH125P5T5G](#) [NLV14049UBDTR2G](#) [NLV37WZ07USG](#) [74VHC541FT\(BE\)](#) [74LVC1G17FW4-7](#)  
[74LVC1G126FZ4-7](#) [BCM6302KMLG](#) [74LVC1G07FZ4-7](#) [74LVC1G125FW4-7](#) [74AUP2G3404FW3-7](#) [MAX9972ACCS+D](#)  
[74AUP1G34FW5-7](#)