

Quad exclusive OR gate

Datasheet - production data

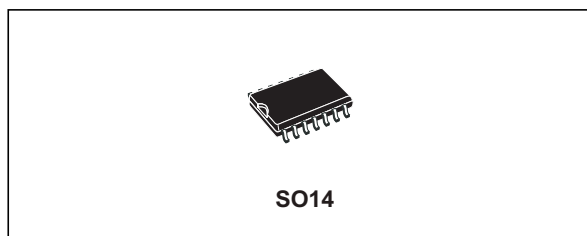

Description

The HCF4070 is a monolithic integrated circuit fabricated in metal oxide semiconductor technology available in an SO14 package.

The HCF4070 contains four independent exclusive OR gates. This device provides the system designer with a means for direct implementation of the exclusive OR gate for applications such as logical comparators, adders/subtractors, parity generators and checkers.

Features

- Medium-speed operation
 $t_{PHL} = t_{PLH} = 70 \text{ ns (typ)}$ at $C_L = 50 \text{ pF}$ and $V_{DD} = 10 \text{ V}$
- Quiescent current specified up to 20 V
- 5 V, 10 V and 15 V parametric ratings
- Input leakage current
 $I_l = 100 \text{ nA (max)}$ at $V_{DD} = 18 \text{ V}$, $T_A = 25 \text{ }^\circ\text{C}$
- 100% tested for quiescent current
- ESD performance
 - HBM: 2 kV
 - MM: 200 V
 - CDM: 1 kV

Applications

- Automotive
- Industrial
- Computer
- Consumer

Table 1. Device summary

Order code	Temperature range	Package	Packing	Marking
HCF4070M013TR	-55 °C to +125 °C	SO14	Tape and reel	HCF4070
HCF4070YM013TR ⁽¹⁾	-40 °C to +125 °C	SO14 (automotive grade)		HCF4070Y

1. Qualification and characterization according to AEC Q100 and Q003 or equivalent, advanced screening according to AEC Q001 and Q002 or equivalent.

Contents

1	Device overview	3
2	Package mechanical data	8
3	Revision history	11

1 Device overview

Figure 1. Pin connections

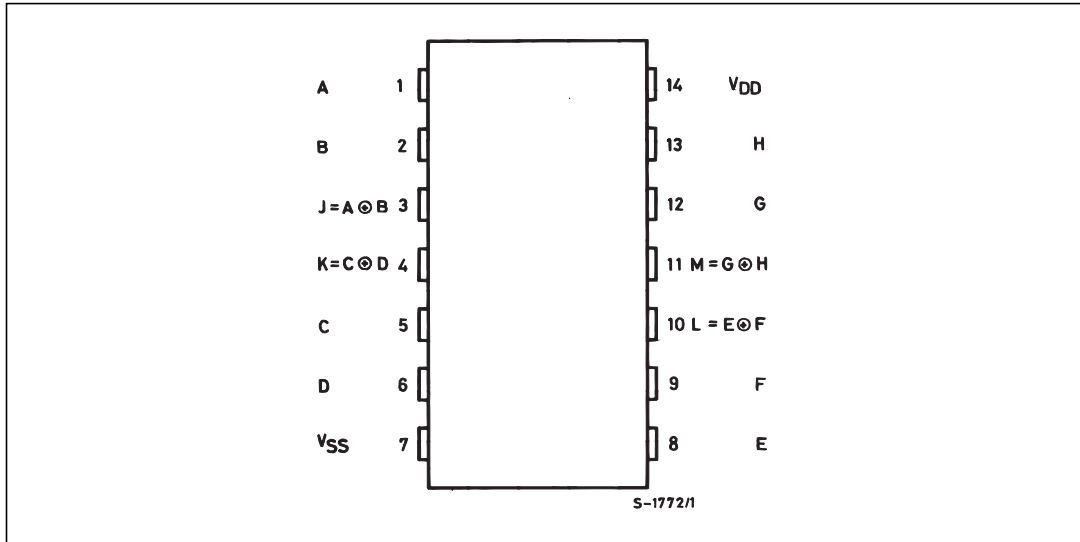

Table 2. Pin description

Pin number	Symbol/name	Function
1, 5, 8, 12	A, C, E, G	Data inputs
2, 6, 9, 13	B, D, F, H	Data inputs
3, 4, 10, 11	J, K, L, M	Data outputs
7	V _{SS}	Negative supply voltage
14	V _{DD}	Positive supply voltage

Figure 2. Input equivalent circuit

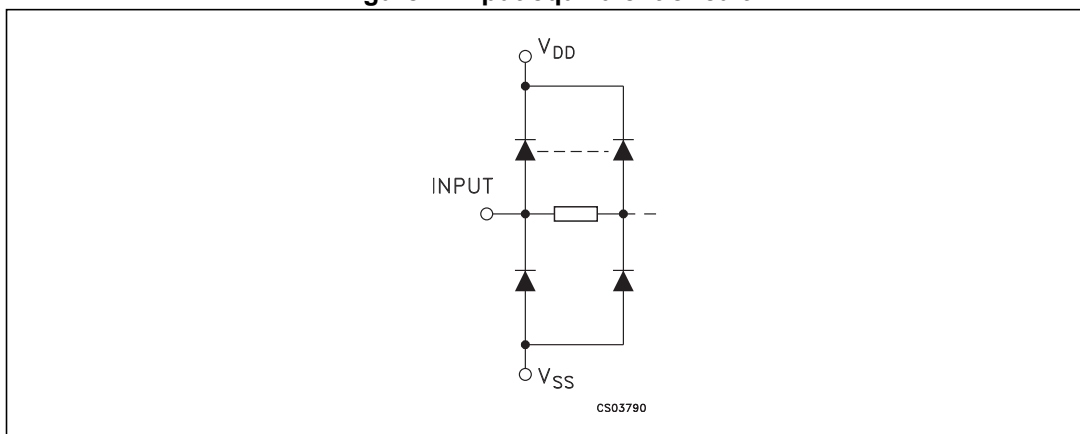

Figure 3. Logic diagram

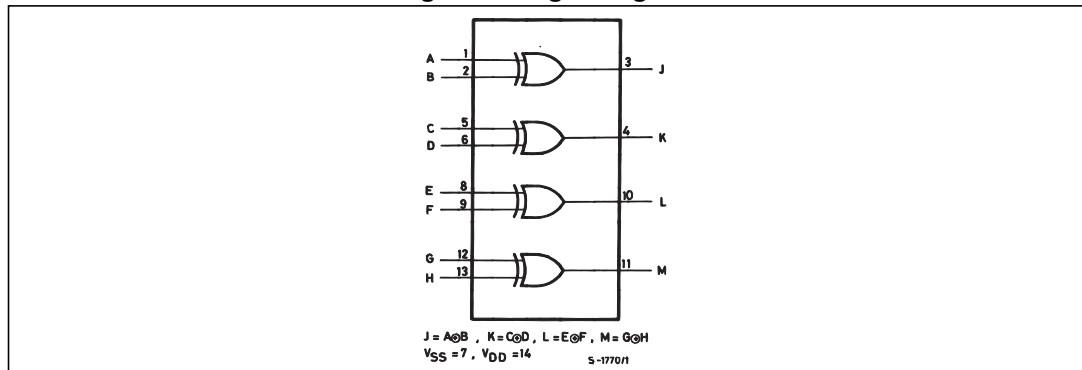

Table 3. Truth table

Inputs		Output
A, C, E, G	B, D, F, H	J, K, L, M
L	L	L
L	H	H
H	L	H
H	H	L

Table 4. Absolute maximum ratings

Symbol	Parameter	Value	Unit
V_{DD}	Supply voltage	-0.5 to +22	V
V_I	DC input voltage	-0.5 to $V_{DD} + 0.5$	V
I_I	DC input current	± 10	mA
P_D	Power dissipation per package	200	mW
	Power dissipation per output transistor	100	mW
T_{op}	Operating temperature	-55 to +125	$^{\circ}C$
T_{stg}	Storage temperature	-65 to +150	$^{\circ}C$

Absolute maximum ratings are those values beyond which damage to the device may occur. Functional operation under these conditions is not implied.

All voltage values are relative to the V_{SS} pin voltage.

Table 5. Recommended operating conditions

Symbol	Parameter		Value	Unit
V_{DD}	Supply voltage		3 to 20	V
V_I	Input voltage		0 to V_{DD}	V
T_{op}	Operating temperature	SO14	-55 to 125	$^{\circ}C$
		SO14 (automotive grade)	-40 to 125	$^{\circ}C$

Table 6. DC specifications

Sym.	Parameter	Test condition				Value						Unit	
		V _I (V)	V _O (V)	I _o (μ A)	V _{DD} (V)	T _A = 25°C			-40 to 85°C		-55 to 125°C		
						Min.	Typ.	Max.	Min.	Max.	Min.		Max.
I _L	Quiescent current	0/5			5		0.02	1		30		30	μ A
		0/10			10		0.02	2		60		60	
		0/15			15		0.02	4		120		120	
		0/20			20		0.04	20		600		600	
V _{OH}	High-level output voltage	0/5		<1	5	4.95			4.95		4.95		V
		0/10		<1	10	9.95			9.95		9.95		
		0/15		<1	15	14.95			14.95		14.95		
V _{OL}	Low-level output voltage	5/0		<1	5		0.05			0.05		0.05	V
		10/0		<1	10		0.05			0.05		0.05	
		15/0		<1	15		0.05			0.05		0.05	
V _{IH}	High-level input voltage		0.5/4.5	<1	5	3.5			3.5		3.5		V
			1/9	<1	10	7			7		7		
			1.5/13.5	<1	15	11			11		11		
V _{IL}	Low-level input voltage		4.5/0.5	<1	5			1.5		1.5		1.5	V
			9/1	<1	10			3		3		3	
			13.5/1.5	<1	15			4		4		4	
I _{OH}	Output drive current	0/5	2.5	<1	5	-1.36	-3.2		-1.15		-1.1		mA
		0/5	4.6	<1	5	-0.44	-1		-0.36		-0.36		
		0/10	9.5	<1	10	-1.1	-2.6		-0.9		-0.9		
		0/15	13.5	<1	15	-3.0	-6.8		-2.4		-2.4		
I _{OL}	Output sink current	0/5	0.4	<1	5	0.44	1		0.36		0.36		mA
		0/10	0.5	<1	10	1.1	2.6		0.9		0.9		
		0/15	1.5	<1	15	3.0	6.8		2.4		2.4		
I _I	Input leakage current	0/18	Any Input		18		$\pm 10^{-5}$	± 0.1		± 1		± 1	μ A
C _I	Input capacitance		Any Input				5	7.5					pF

The noise margin for both the "1" and "0" level is: 1 V min. with V_{DD} = 5 V, 2 V min. with V_{DD} = 10 V, 2.5 V min. with V_{DD} = 15 V.

Table 7. Dynamic electrical characteristics
 ($T_{amb} = 25\text{ }^{\circ}\text{C}$, $C_L = 50\text{ pF}$, $R_L = 200\text{ k}\Omega$, $t_r = t_f = 20\text{ ns}$)

Symbol	Parameter	Test condition	Value ⁽¹⁾			Unit
		V _{DD} (V)	Min.	Typ.	Max.	
t _{PLH} t _{PHL}	Propagation delay time	5		140	280	ns
		10		70	130	
		15		50	100	
t _{TLH} t _{THL}	Output transition time	5		100	200	ns
		10		50	100	
		15		40	80	

1. Typical temperature coefficient for all V_{DD} values is 0.3%/°C.

Figure 4. Test circuit

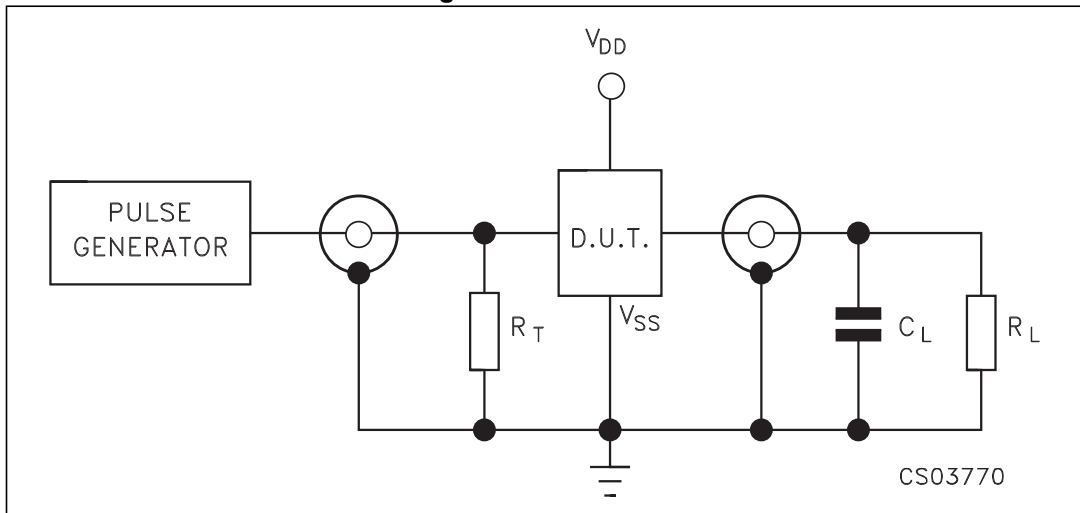

1. $C_L = 50\text{ pF}$ or equivalent (includes jig and probe capacitance)
2. $R_L = 200\text{ k}\Omega$
3. $R_T = Z_{OUT}$ of pulse generator (typically $50\text{ }\Omega$)

Figure 5. Waveform - propagation delay times (f = 1 MHz; 50% duty cycle)

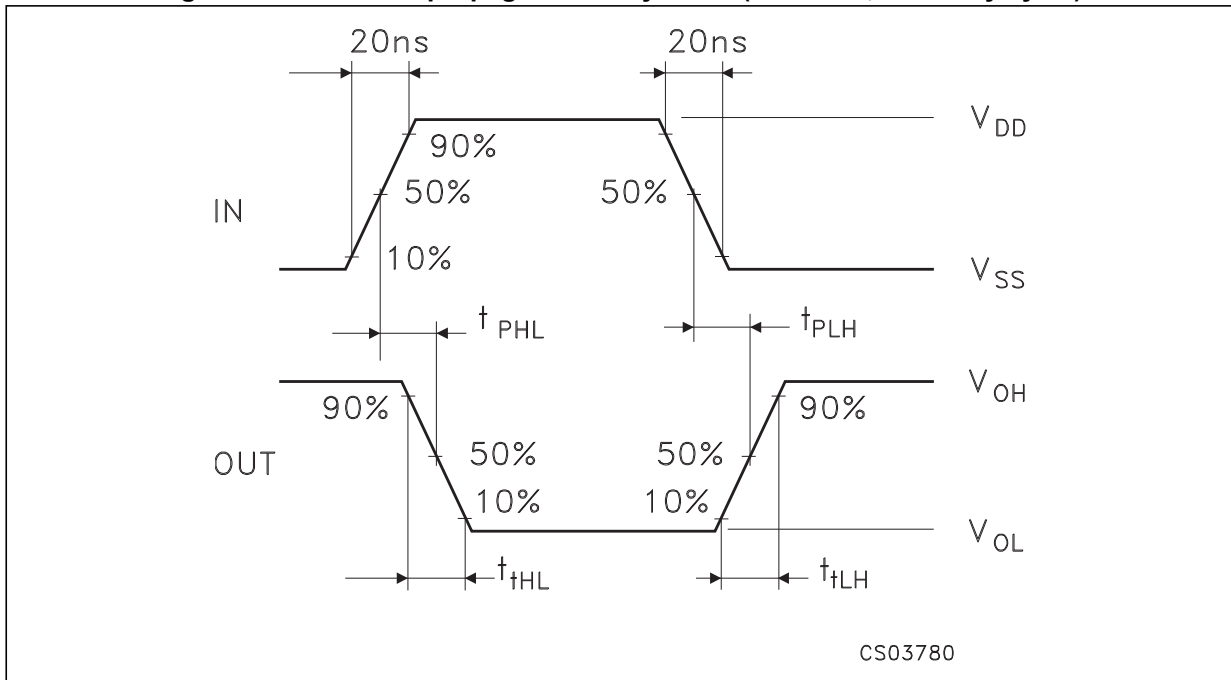

2 Package mechanical data

In order to meet environmental requirements, ST offers these devices in different grades of ECOPACK[®] packages, depending on their level of environmental compliance. ECOPACK[®] specifications, grade definitions and product status are available at: www.st.com. ECOPACK[®] is an ST trademark.

SO-14 MECHANICAL DATA

DIM.	mm.			inch		
	MIN.	TYP	MAX.	MIN.	TYP.	MAX.
A			1.75			0.068
a1	0.1		0.2	0.003		0.007
a2			1.65			0.064
b	0.35		0.46	0.013		0.018
b1	0.19		0.25	0.007		0.010
C		0.5			0.019	
c1	45° (typ.)					
D	8.55		8.75	0.336		0.344
E	5.8		6.2	0.228		0.244
e		1.27			0.050	
e3		7.62			0.300	
F	3.8		4.0	0.149		0.157
G	4.6		5.3	0.181		0.208
L	0.5		1.27	0.019		0.050
M			0.68			0.026
S	8° (max.)					

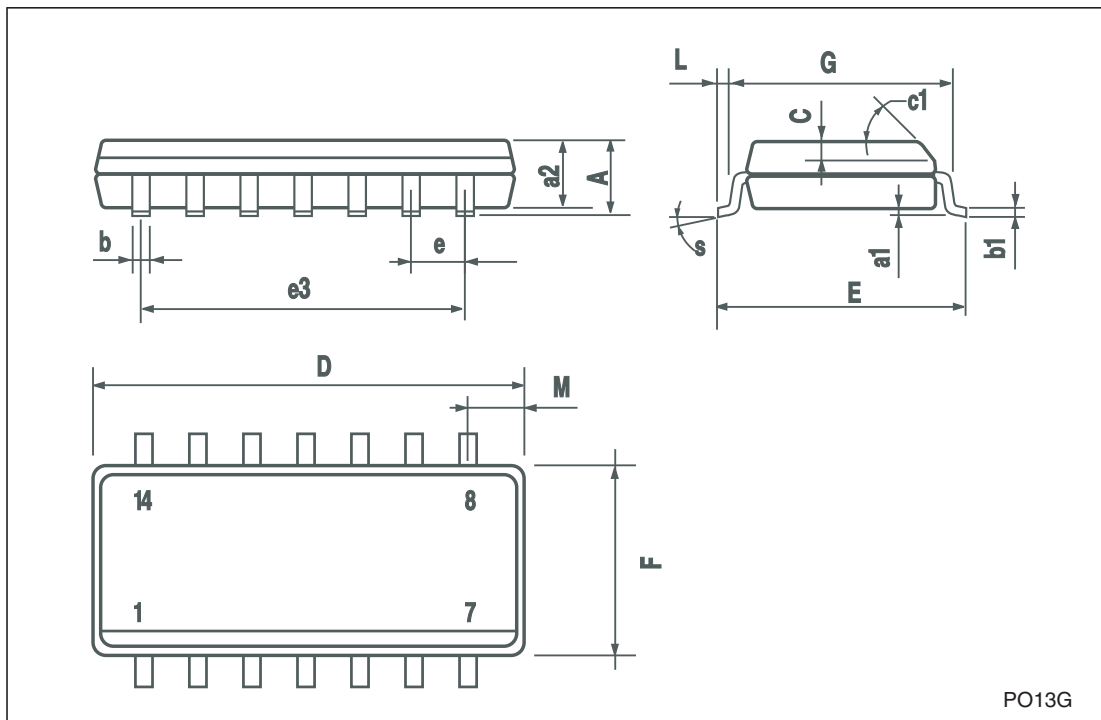

PO13G

Tape & Reel SO-14 MECHANICAL DATA

DIM.	mm.			inch		
	MIN.	TYP.	MAX.	MIN.	TYP.	MAX.
A			330			12.992
C	12.8		13.2	0.504		0.519
D	20.2			0.795		
N	60			2.362		
T			22.4			0.882
Ao	6.4		6.6	0.252		0.260
Bo	9		9.2	0.354		0.362
Ko	2.1		2.3	0.082		0.090
Po	3.9		4.1	0.153		0.161
P	7.9		8.1	0.311		0.319

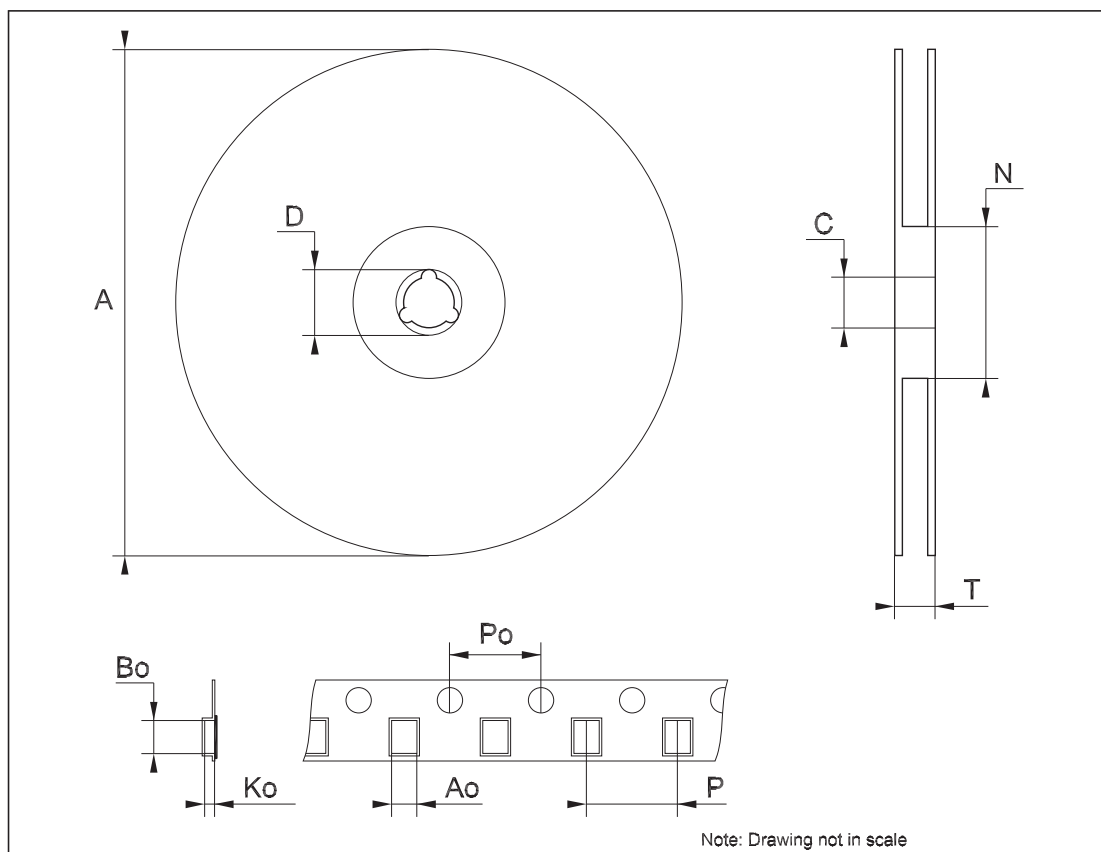

3 Revision history

Table 8. Document revision history

Date	Revision	Changes
11-Jun-2012	3	Added <i>Applications on page 1</i> Updated <i>Table 1: Device summary</i> Revised document presentation, minor textual updates
15-Jun-2012	4	Updated temperature range in <i>Table 1</i> Updated T _{op} in <i>Table 4</i> and <i>5</i>
06-Jan-2014	5	Removed DIP package option Added ESD performance to <i>Features</i> Added packing and marking to <i>Table 1: Device summary</i> Updated footnote <i>1</i> of <i>Table 1: Device summary</i>

Please Read Carefully:

Information in this document is provided solely in connection with ST products. STMicroelectronics NV and its subsidiaries ("ST") reserve the right to make changes, corrections, modifications or improvements, to this document, and the products and services described herein at any time, without notice.

All ST products are sold pursuant to ST's terms and conditions of sale.

Purchasers are solely responsible for the choice, selection and use of the ST products and services described herein, and ST assumes no liability whatsoever relating to the choice, selection or use of the ST products and services described herein.

No license, express or implied, by estoppel or otherwise, to any intellectual property rights is granted under this document. If any part of this document refers to any third party products or services it shall not be deemed a license grant by ST for the use of such third party products or services, or any intellectual property contained therein or considered as a warranty covering the use in any manner whatsoever of such third party products or services or any intellectual property contained therein.

UNLESS OTHERWISE SET FORTH IN ST'S TERMS AND CONDITIONS OF SALE ST DISCLAIMS ANY EXPRESS OR IMPLIED WARRANTY WITH RESPECT TO THE USE AND/OR SALE OF ST PRODUCTS INCLUDING WITHOUT LIMITATION IMPLIED WARRANTIES OF MERCHANTABILITY, FITNESS FOR A PARTICULAR PURPOSE (AND THEIR EQUIVALENTS UNDER THE LAWS OF ANY JURISDICTION), OR INFRINGEMENT OF ANY PATENT, COPYRIGHT OR OTHER INTELLECTUAL PROPERTY RIGHT.

ST PRODUCTS ARE NOT DESIGNED OR AUTHORIZED FOR USE IN: (A) SAFETY CRITICAL APPLICATIONS SUCH AS LIFE SUPPORTING, ACTIVE IMPLANTED DEVICES OR SYSTEMS WITH PRODUCT FUNCTIONAL SAFETY REQUIREMENTS; (B) AERONAUTIC APPLICATIONS; (C) AUTOMOTIVE APPLICATIONS OR ENVIRONMENTS, AND/OR (D) AEROSPACE APPLICATIONS OR ENVIRONMENTS. WHERE ST PRODUCTS ARE NOT DESIGNED FOR SUCH USE, THE PURCHASER SHALL USE PRODUCTS AT PURCHASER'S SOLE RISK, EVEN IF ST HAS BEEN INFORMED IN WRITING OF SUCH USAGE, UNLESS A PRODUCT IS EXPRESSLY DESIGNATED BY ST AS BEING INTENDED FOR "AUTOMOTIVE, AUTOMOTIVE SAFETY OR MEDICAL" INDUSTRY DOMAINS ACCORDING TO ST PRODUCT DESIGN SPECIFICATIONS. PRODUCTS FORMALLY ESCC, QML OR JAN QUALIFIED ARE DEEMED SUITABLE FOR USE IN AEROSPACE BY THE CORRESPONDING GOVERNMENTAL AGENCY.

Resale of ST products with provisions different from the statements and/or technical features set forth in this document shall immediately void any warranty granted by ST for the ST product or service described herein and shall not create or extend in any manner whatsoever, any liability of ST.

ST and the ST logo are trademarks or registered trademarks of ST in various countries.

Information in this document supersedes and replaces all information previously supplied.

The ST logo is a registered trademark of STMicroelectronics. All other names are the property of their respective owners.

© 2014 STMicroelectronics - All rights reserved

STMicroelectronics group of companies

Australia - Belgium - Brazil - Canada - China - Czech Republic - Finland - France - Germany - Hong Kong - India - Israel - Italy - Japan - Malaysia - Malta - Morocco - Philippines - Singapore - Spain - Sweden - Switzerland - United Kingdom - United States of America

www.st.com

X-ON Electronics

Largest Supplier of Electrical and Electronic Components

Click to view similar products for [Logic Gates](#) category:

Click to view products by [STMicroelectronics](#) manufacturer:

Other Similar products are found below :

[74HC85N](#) [NLU1G32AMUTCG](#) [CD4068BE](#) [NL17SG32P5T5G](#) [NL17SG86DFT2G](#) [NLV14001UBDR2G](#) [NLX1G11AMUTCG](#)
[NLX1G97MUTCG](#) [74LS38](#) [74LVC32ADTR2G](#) [MC74HCT20ADTR2G](#) [NLV17SZ00DFT2G](#) [NLV17SZ02DFT2G](#) [NLV74HC02ADR2G](#)
[74HC32S14-13](#) [74LS133](#) [74LVC1G32Z-7](#) [M38510/30402BDA](#) [74LVC1G86Z-7](#) [74LVC2G08RA3-7](#) [NLV74HC08ADTR2G](#)
[NLV74HC14ADR2G](#) [NLV74HC20ADR2G](#) [NLX2G86MUTCG](#) [5962-8973601DA](#) [74LVC2G02HD4-7](#) [NLU1G00AMUTCG](#)
[74LVC2G32RA3-7](#) [74LVC2G00HD4-7](#) [NL17SG02P5T5G](#) [74LVC2G00HK3-7](#) [74LVC2G86HK3-7](#) [NL17SG08DFT2G](#)
[NLX1G99DMUTWG](#) [NLVVHC1G00DFT2G](#) [NLVHC1G08DFT2G](#) [NLV7SZ57DFT2G](#) [NLV74VHC04DTR2G](#) [NLV27WZ86USG](#)
[NLV27WZ00USG](#) [NLU1G86CMUTCG](#) [NLU1G08CMUTCG](#) [NL17SZ32P5T5G](#) [NL17SZ00P5T5G](#) [NL17SH02P5T5G](#) [74AUP2G00RA3-7](#)
[NLV74HC02ADTR2G](#) [NLX1G332CMUTCG](#) [NL17SG86P5T5G](#) [NL17SZ05P5T5G](#)