

High performance current mode LED controller

Datasheet - production data

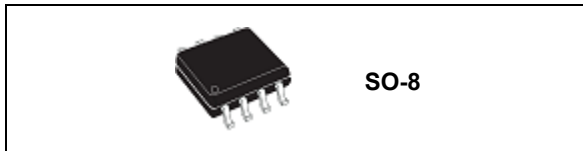

Description

The HVLED002 control IC provides the necessary features to implement off-line or DC to DC fixed frequency current mode control schemes to implement LED drivers. Internally implemented circuits include a trimmed oscillator for the precise duty cycle control, undervoltage lockout, a precision reference trimmed for accuracy at the error amplifier input, a PWM comparator which also provides current limit control and a totem pole output stage designed to the source or sink high peak current. The output stage, suitable for driving N-channel MOSFETs, is low in the off-state.

Features

- Trimmed oscillator for precise frequency control
- Oscillator frequency guaranteed at 250 kHz
- Current mode operation to 500 kHz
- Latching PWM for cycle-by-cycle current limiting
- Internally trimmed reference with undervoltage lockout
- High current totem pole output
- Undervoltage lockout with hysteresis
- Low start-up and operating current

Table 1. Device summary

Order codes	Package	Packaging
HVLED002	SO8	Tube
HVLED002TR		Tape and reel

Figure 1. Block diagram

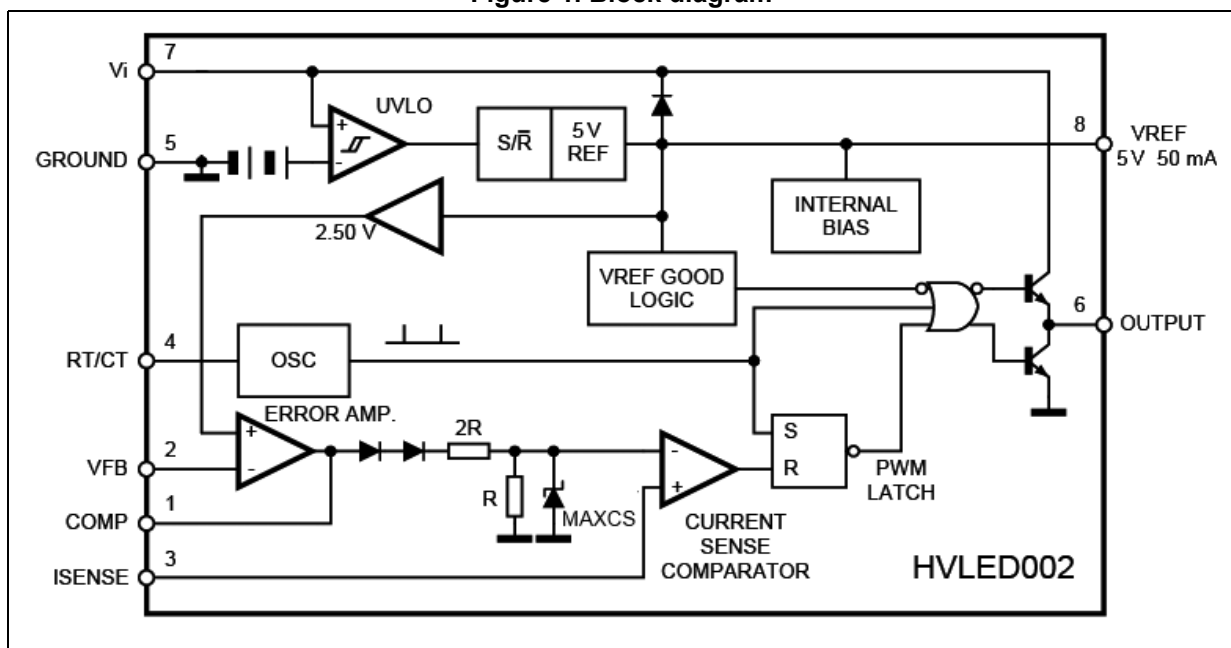

Contents

- 1 Absolute maximum ratings 4**
- 2 Pin connection and functions 5**
- 3 Thermal data 5**
- 4 Electrical characteristics 6**
- 5 Application information 12**
 - 5.1 Supply voltage and undervoltage lockout 12
 - 5.2 Reference voltage 12
 - 5.3 Oscillator 12
 - 5.4 Current sense 13
 - 5.5 Error amplifier 14
 - 5.6 Totem pole output 14
 - 5.7 Typical application 15
- 6 Package information 16**
 - 6.1 SO-8 package information 16
- 7 Revision history 18**

List of figures

Figure 1. Block diagram 1

Figure 2. Pin connection (top view) 5

Figure 3. Open loop test circuit 8

Figure 4. Timing resistor vs. oscillator frequency 8

Figure 5. Output deadtime vs. oscillator frequency 8

Figure 6. Oscillator discharge current vs. temperature 9

Figure 7. Maximum output duty cycle vs. timing resistor 9

Figure 8. Error amplifier open loop gain and phase vs. frequency 9

Figure 9. Current sense input threshold vs. error amplifier output voltage 9

Figure 10. Reference voltage change vs. source current 10

Figure 11. Reference short-circuit current vs. temperature 10

Figure 12. Output saturation voltage vs. load current 10

Figure 13. Supply current vs. supply voltage 10

Figure 14. Oscillator and output waveforms 10

Figure 15. Error amplifier configuration 10

Figure 20. Error amplifier compensation 11

Figure 16. Undervoltage lockout 11

Figure 17. Current sense circuit 11

Figure 18. Soft-start circuit 11

Figure 19. External clock synchronization 11

Figure 21. Leading edge blanking circuitries 13

Figure 22. Shutdown circuitries 14

Figure 23. Typical application 15

Figure 24. SO-8 package outline 16

1 Absolute maximum ratings

Table 2. Absolute maximum ratings⁽¹⁾

Symbol	Parameter	Value	Unit
V_i	Supply voltage	30	V
I_O	Output current	± 1	A
E_O	Output energy (capacitive load)	5	μJ
	Analog inputs (pins 2, 3)	- 0.3 to 5.5	V
	Error amplifier output sink current	10	mA

1. All voltages are with respect to the pin 5, all currents are positive into the specified terminal.

2 Pin connection and functions

Figure 2. Pin connection (top view)

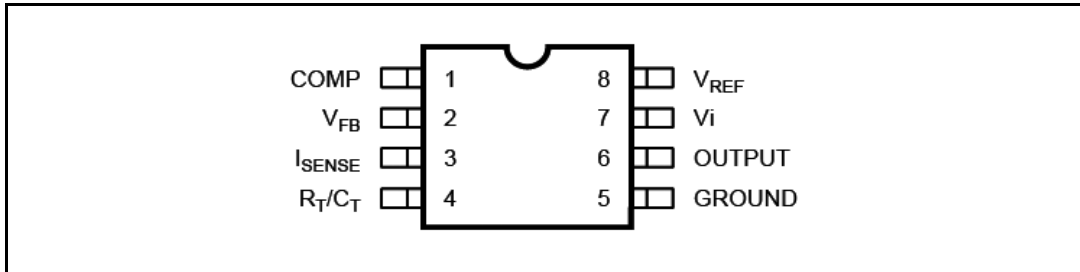

Table 3. Pin functions

No.	Function	Description
1	COMP	This pin is the error amplifier output and is made available for loop compensation.
2	V _{FB}	This is the inverting input of the error amplifier. It is normally connected to the switching power supply output through a resistor divider.
3	I _{SENSE}	A voltage proportional to the inductor current is connected to this input. The PWM uses this information to terminate the output switch conduction.
4	R _T /C _T	The oscillator frequency and maximum output duty cycle are programmed by the connecting resistor R _T to V _{REF} and the capacitor C _T to ground. An operation to 500 kHz is possible.
5	GROUND	This pin is the ground reference of the device.
6	OUTPUT	This output directly drives the gate of a power MOSFET. Peak currents up to 1 A are sourced and sunk by this pin.
7	V _i	This pin is the positive supply of the control IC.
8	V _{REF}	This is the reference output. It provides the charging current for the capacitor C _T through the resistor R _T .

3 Thermal data

Table 4. Thermal data

Symbol	Description	SO8	Unit
R _{th j-amb}	Thermal resistance junction ambient	150	°C/W
T _{stg}	Storage temperature range	-65 to 150	°C
T _J	Junction operating temperature	-40 to 150	°C
T _L	Lead temperature (soldering 10 s)	300	°C

4 Electrical characteristics

Unless otherwise stated, these specifications apply for $0 \leq T_{\text{amb}} \leq 85 \text{ }^\circ\text{C}$; $V_i = 15 \text{ V}$; $R_T = 10 \text{ K}\Omega$; $C_T = 3.3 \text{ nF}^{(a)}$.

Table 5. Electrical characteristics

Symbol	Parameter	Test conditions	Min.	Typ.	Max.	Unit
SUPPLY VOLTAGE						
V_i	Max. operative volt.				25	V
REFERENCE SECTION						
V_{REF}	Output voltage	$T_J = 25 \text{ }^\circ\text{C}$, $I_o = 1 \text{ mA}$	4.95	5.00	5.05	V
ΔV_{REF}	Line regulation	$12 \text{ V} \leq V_i \leq 25 \text{ V}$		2	20	mV
ΔV_{REF}	Load regulation	$1 \leq I_o \leq 20 \text{ mA}$		3	25	mV
$\Delta V_{\text{REF}}/\Delta T$	Temperature stability	(1)		0.2		mV/°C
	Total output variation	Line, load, temperature	4.82		5.18	V
e_N	Output noise voltage	$10 \text{ Hz} \leq f \leq 10 \text{ KHz}$, $T_j = 25 \text{ }^\circ\text{C}^{(1)}$		50		μV
	Long term stability	$T_{\text{amb}} = 125 \text{ }^\circ\text{C}$, 1000 hrs ⁽¹⁾		5	25	mV
I_{SC}	Output short-circuit		-30	-100	-180	mA
OSCILLATOR SECTION						
f_{OSC}	Frequency	$T_J = 25 \text{ }^\circ\text{C}$ $T_A = 0 \text{ to } 85 \text{ }^\circ\text{C}$ $T_J = 25 \text{ }^\circ\text{C}$ ($R_T = 6.2 \text{ k}\Omega$, $C_T = 1 \text{ nF}$)	49 48 225	52 - 250	55 56 275	KHz
$\Delta f_{\text{OSC}}/\Delta V$	Frequency change with volt.	$V_{\text{CC}} = 12 \text{ V to } 25 \text{ V}$	-	0.2	1	%
$\Delta f_{\text{OSC}}/\Delta T$	Frequency change with temp.	$T_{\text{amb}} = 0 \text{ }^\circ\text{C to } 85 \text{ }^\circ\text{C}$	-	0.5	-	%
V_{OSC}	Oscillator voltage swing	Peak-to-peak	-	1.6	-	V
I_{dischg}	Discharge current ($V_{\text{OSC}} = 2 \text{ V}$)	$T_J = 25 \text{ }^\circ\text{C}$	7.8	8.3	8.8	mA
		$T_A = 0 \text{ }^\circ\text{C to } 85 \text{ }^\circ\text{C}$	7.6	-	8.8	mA
ERROR AMPLIFIER SECTION						
$V_{\text{REF,EA}}$	Input voltage	$V_{(\text{COMP})} = 2.5 \text{ V}$	2.42	2.50	2.58	V
I_b	Input bias current	$V_{\text{FB}} = 5 \text{ V}$		-0.1	-2	μA
	A_{VOL}	$2 \text{ V} \leq V_o \leq 4 \text{ V}$	65	90		dB
BW	Unity gain bandwidth	$T_J = 25 \text{ }^\circ\text{C}^{(1)}$	0.7	1		MHz
PSRR	Power supply reject. ratio	$12 \text{ V} \leq V_i \leq 25 \text{ V}$	60	70		dB
I_o	Output sink current	$V_{(\text{VFB})} = 2.7 \text{ V}$, $V_{(\text{COMP})} = 1.1 \text{ V}$	2	12		mA

a. Max. package power dissipation limits must be respected; low duty cycle pulse techniques are used during the test maintaining T_J as close to T_{amb} as possible.

Table 5. Electrical characteristics (continued)

Symbol	Parameter	Test conditions	Min.	Typ.	Max.	Unit
I_o	Output source current	$V_{(VFB)} = 2.3 \text{ V}$, $V_{(COMP)} = 5 \text{ V}$	-0.5	-1		mA
	V_{COMP} high	$V_{(VFB)} = 2.3 \text{ V}$; $R_L = 15 \text{ K}\Omega$ between COMP and ground	5	6.2		V
	V_{COMP} low	$V_{(VFB)} = 2.7 \text{ V}$; $R_L = 15 \text{ K}\Omega$ between COMP and VREF		0.8	1.1	V
CURRENT SENSE SECTION						
G_V	Gain	(2), (3)		3		V/V
MAXCS	Maximum input signal	$V_{(COMP)} = 5.6 \text{ V}$	258	267	276	mV
SVR	Supply voltage rejection	$12 \leq V_i \leq 25 \text{ V}^{(1)}$		70		dB
I_b	Input bias current			-2	-10	μA
	Delay to output			150	300	ns
OUTPUT SECTION						
V_{OL}	Output low level	$I_{SINK} = 20 \text{ mA}$		0.1	0.4	V
		$I_{SINK} = 200 \text{ mA}$		1.6	2.2	V
V_{OH}	Output high level	$I_{SOURCE} = 20 \text{ mA}$	13	13.5		V
		$I_{SOURCE} = 200 \text{ mA}$	12	13.5		V
V_{OLS}	UVLO saturation	$V_{CC} = 6 \text{ V}$; $I_{SINK} = 1 \text{ mA}$		0.1	1.1	V
t_r	Rise time	$T_J = 25 \text{ }^\circ\text{C}$; $C_L = 1 \text{ nF}^{(1)}$		50	150	ns
t_f	Fall time	$T_J = 25 \text{ }^\circ\text{C}$; $C_L = 1 \text{ nF}^{(1)}$		50	150	ns
UNDERVOLTAGE LOCKOUT SECTION						
V_{ON}	Start threshold	Increasing voltage	7.8	8.4	9.0	V
V_{OFF}	Min. operating voltage after turn-on	Decreasing voltage	7.0	7.6	8.2	V
PWM SECTION						
	Maximum duty cycle		94	96	100	%
	Minimum duty cycle				0	%
TOTAL STANDBY CURRENT						
I_{st}	Start-up current			0.3	0.5	mA
I_i	Operating supply current	$V_{(VFB)} = V_{(COMP)} = 0 \text{ V}$		12	17	mA

1. These parameters, although guaranteed, are not 100% tested in production.
2. Parameter measured at the trip point of the latch with $V_{(VFB)} = 0$.
3. Gain defined as : $A = \Delta V_{(COMP)} / \Delta V_{(ISENSE)}$; $0 \leq V_{(ISENSE)} \leq 267 \text{ mV}$.

Figure 3. Open loop test circuit

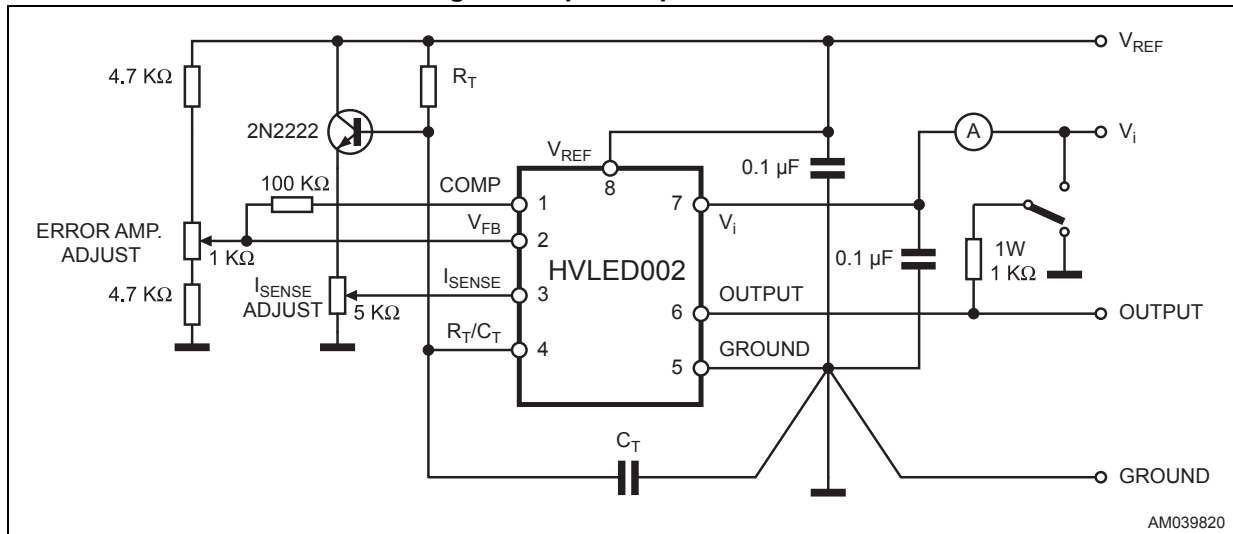

High peak currents associated with capacitive loads necessitate careful grounding techniques. Timing and bypass capacitors should be connected close to the pin 5 in a single point ground. The transistor and 5 KΩ potentiometer are used to sample the oscillator waveform and apply an adjustable ramp to the pin 3.

Figure 4. Timing resistor vs. oscillator frequency

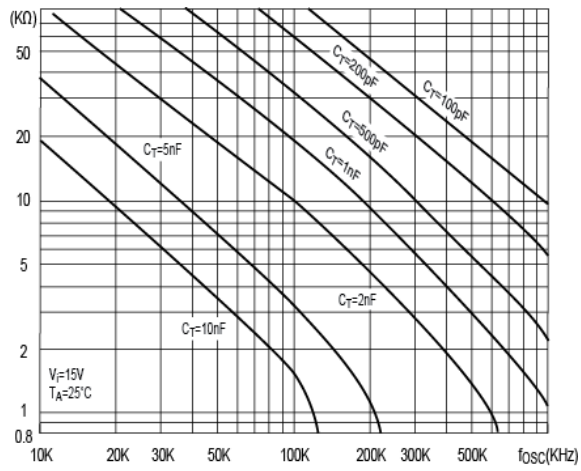

Figure 5. Output deadtime vs. oscillator frequency

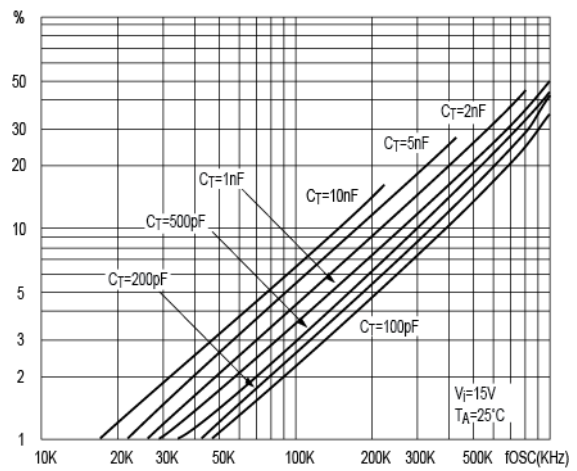

Figure 6. Oscillator discharge current vs. temperature

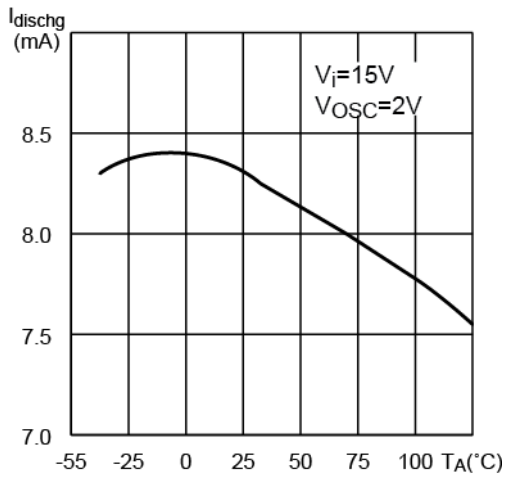

Figure 7. Maximum output duty cycle vs. timing resistor

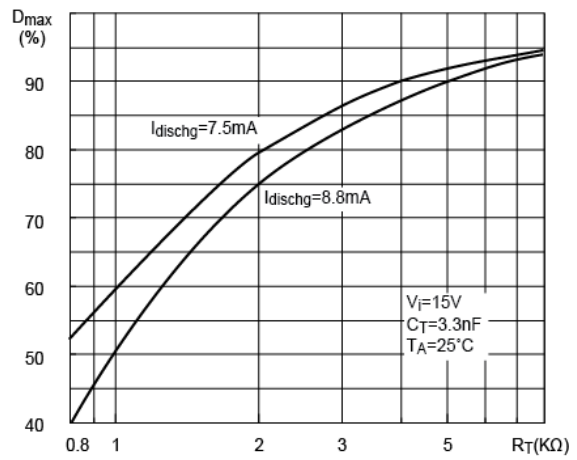

Figure 8. Error amplifier open loop gain and phase vs. frequency

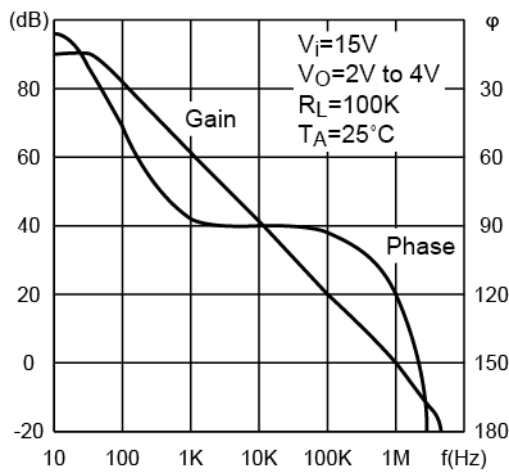

Figure 9. Current sense input threshold vs. error amplifier output voltage

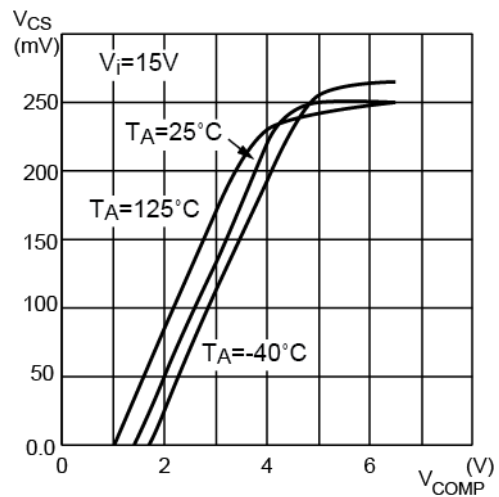

Figure 10. Reference voltage change vs. source current

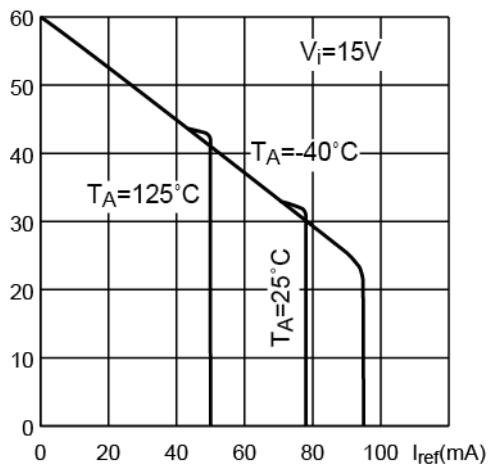

Figure 11. Reference short-circuit current vs. temperature

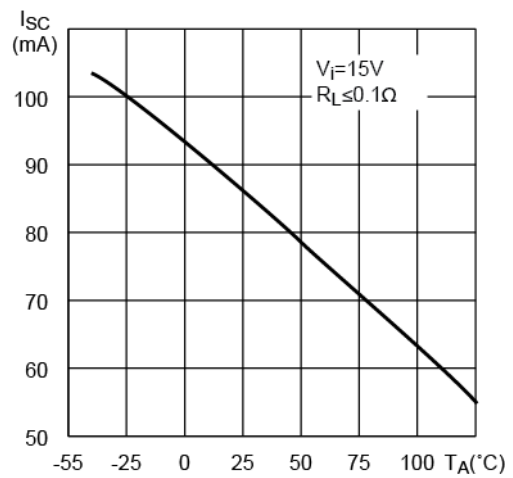

Figure 12. Output saturation voltage vs. load current

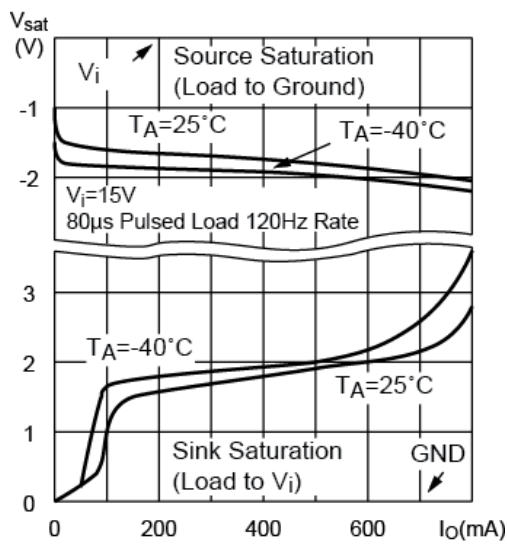

Figure 13. Supply current vs. supply voltage

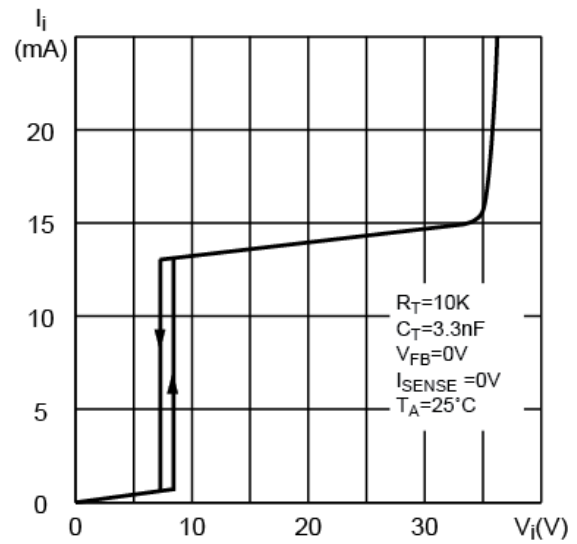

Figure 14. Oscillator and output waveforms

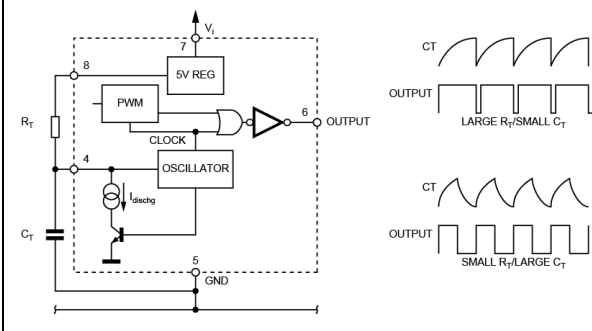

Figure 15. Error amplifier configuration

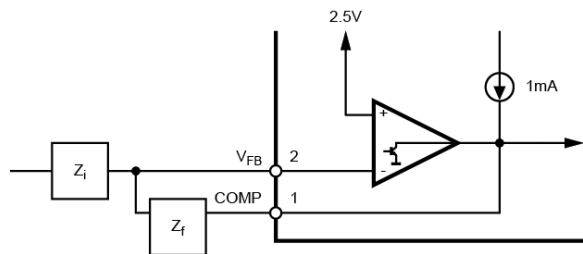

Figure 16. Undervoltage lockout

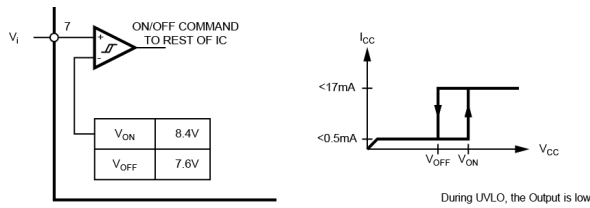

Figure 17. Current sense circuit

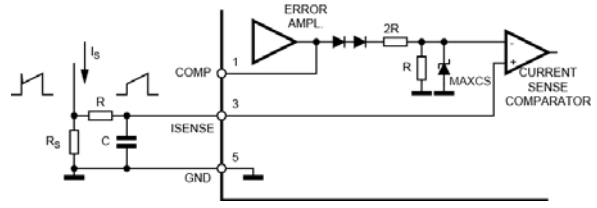

Figure 18. Soft-start circuit

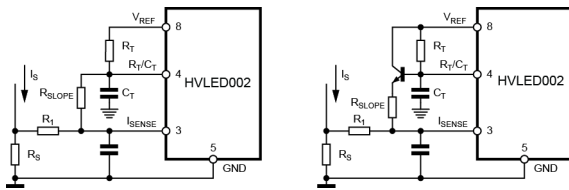
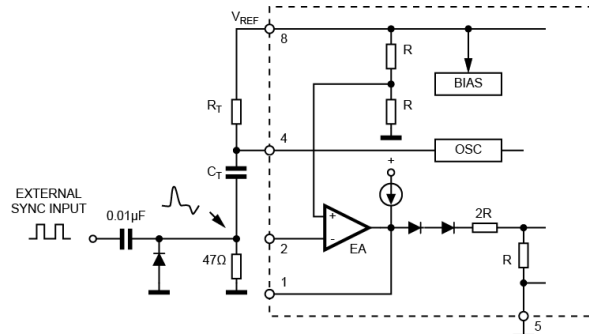
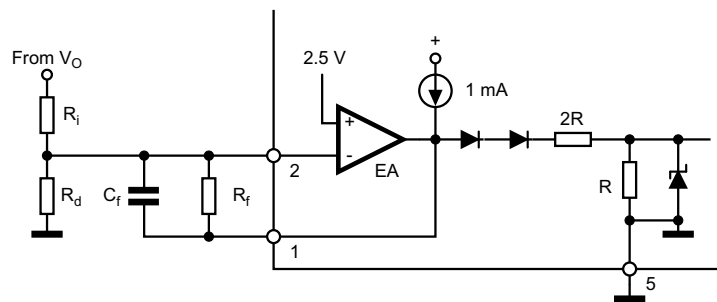

Figure 19. External clock synchronization



The diode clamp is required if the Sync amplitude is large enough to cause the bottom side of C_T to go more than 300mV below ground

Figure 20. Error amplifier compensation



Error amplifier compensation circuit for stabilizing any current mode topology except for boost and flyback converters operating with continuous inductor current.

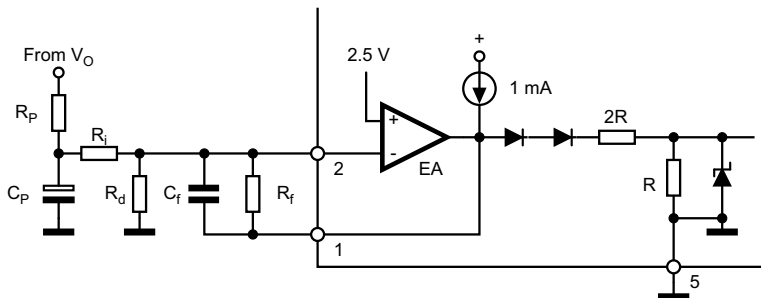

Error amplifier compensation circuit for stabilizing current mode boost and flyback topologies operating with continuous inductor current.

AM039817

5 Application information

5.1 Supply voltage and undervoltage lockout

The HVLED002 device is able to operate with a very wide range of supply voltage between 8.4 V and 30 V. The UVLO circuit insures that VCC is adequate to make the HVLED002 fully operational before enabling the output stage. [Figure 16](#) shows that the UVLO turn-on and turn-off thresholds are fixed internally at 8.4 V and 7.6 V respectively. The hysteresis prevents V_{CC} oscillations during power sequencing and the start-up current is less than 1 mA.

During UVLO, the output driver is in a low state and it can easily sink 1 mA, enough to insure the MOSFET is held off.

5.2 Reference voltage

The HVLED002 contains a precision reference voltage (5 V) that generates all the internal reference voltages such as the error amplifier's reference (connected to its non-inverting input), current sense clamp limit (MAXCS) and oscillator's internal bias currents and thresholds.

The reference voltage is also available on the VREF pin that, thanks to its high output current capability (over 20 mA), is able to supply not only nearby passive circuitries but also auxiliary microcontrollers.

The pin must be bypassed with at least a 0.1 µF ceramic capacitor placed as close as possible to the respective VREF and GND pins.

5.3 Oscillator

The HVLED002 oscillator is programmed as shown in [Figure 14](#). The timing capacitor CT is charged from a reference voltage (e.g.: VREF) through the timing resistor RT, and discharged by an internal current source.

The MOSFET is turned on (GD pin high) when the oscillator starts the charge of the CT. As soon as the voltage of the CT reaches an upper threshold the internal discharge current is activated until the CT voltage reaches a lower threshold. This occurrence initiates a new oscillator cycle.

The difference between the upper and the lower thresholds (Vosc) determines the duration of charging and discharging time. During the discharging time (also called deadtime) the MOSFET is off and any spurious GD triggering is avoided. The deadtime also limits the maximum obtainable duty cycle.

The oscillator can be differently connected to external circuitry to obtain different operating schemes. Connecting the RT to VREF a very accurate fixed frequency operation is achieved: the RT,CT combinations are plot into [Figure 5 on page 8](#), [Figure 6](#) and [Figure 8](#) for a quick reference, or calculated as follows:

Equation 1

$$FOSC \text{ (kHz)} = 1.72 / [RT \text{ (k}\Omega) \times CT \text{ (}\mu\text{F)}]$$

Connecting the RT to a variable voltage, dependency of the operating frequency on said voltage is introduced. A pull-down switch can be used to reset the CT during the MOSFET's on time, for example to operate in fixed off time. A synchronous operation is also possible using circuitries like the one proposed as an example in [Figure 19](#). The HVLED002 oscillator can be used to a maximum of 500 kHz.

5.4 Current sense

The peak current mode operation of the HVLED002 is made by the embedded current sense comparator: the said element turns off the MOSFET as soon as the current sense input voltage is greater than the internal threshold derived by the COMP pin voltage ([Figure 17](#)).

The current sense pin (ISENSE) is normally connected to a shunt resistor, put in series with the main switch, but different connections are also possible.

Under the normal operation the threshold voltage (VCS) is controlled by the E/A according to the following relation:

Equation 2

$$VCS = 1/3 * (VCOMP - 1.4 V)$$

VCS is upper limited to MAXCS to reduce the shunt resistor power dissipation without the need of current transformers or offsets circuitries. This parameter is beneficial in those applications where both the peak current accuracy and the operating power dissipation are critical aspects (e.g.: LED secondary side LED current regulators).

When the sensing current resistor is in series with the power switch, the current waveform will often have a large spike at its leading edge due to parasitic capacitances and gate driver charging currents. A very simple leading edge blanking (LEB) circuit consists on an RC filter, but more effective active circuitries are also possible.

Figure 21. Leading edge blanking circuitries

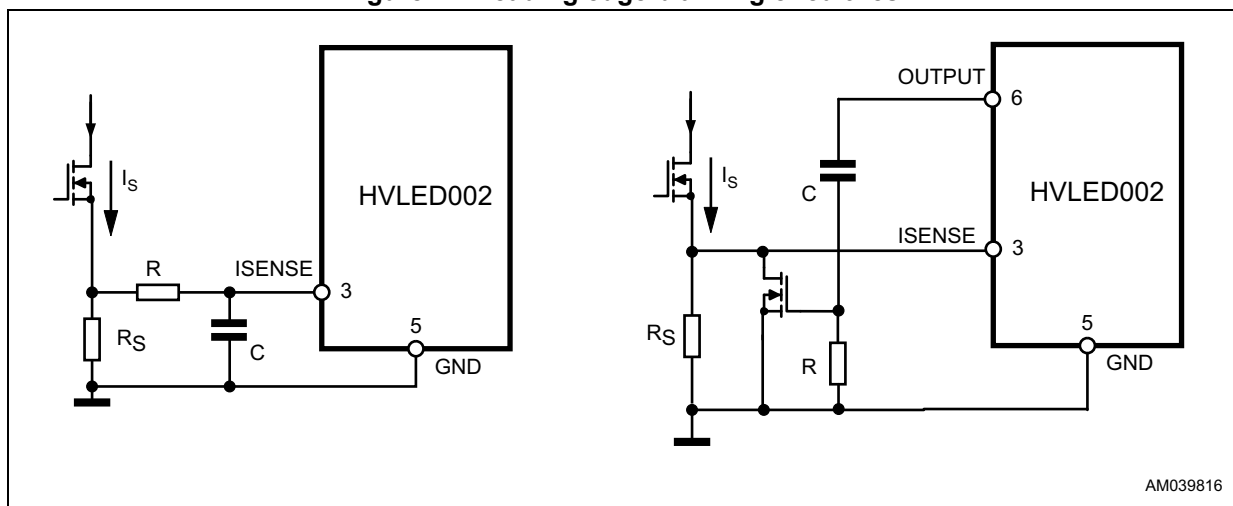

AM039816

5.5 Error amplifier

An error amplifier (E/A) structure is present in the HVLED002 (Figure 15 on page 10). The non-inverting input is internally connected to a very precise reference voltage ($2.5\text{ V} \pm 2\%$). The E/A output and inverting input are connected respectively to the pin 1 and 2, available for external compensation. The E/A output will source at least 0.5 mA and sink 2 mA. Figure 8 on page 9 shows the open loop frequency response of the E/A.

The output of the error amplifier can be forced to ground in different ways to shut down the application as shown in Figure 22.

Figure 22. Shutdown circuitries

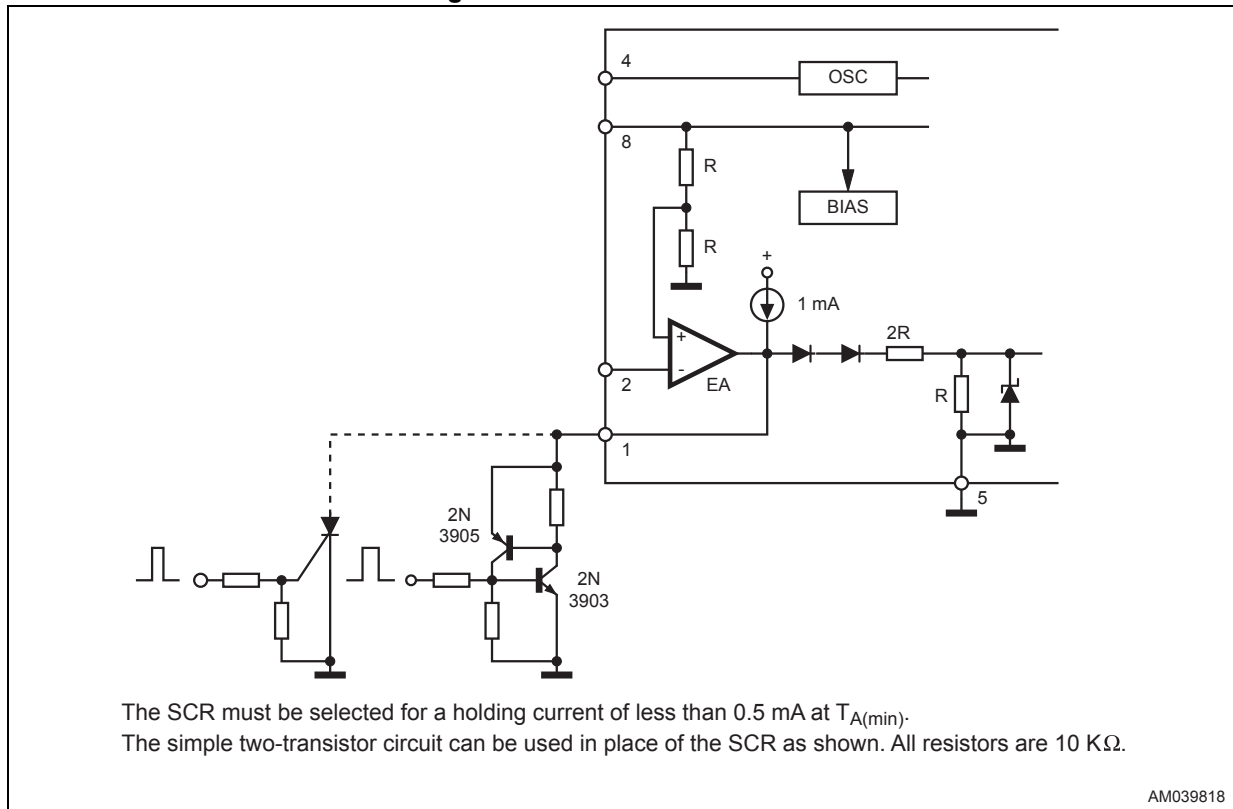

5.6 Totem pole output

The HVLED002 has a single totem pole output which can be operated to the ± 1 Amp peak current for driving MOSFET gates, and a + 200 mA average current for bipolar power transistors.

Cross conduction between the driver's output transistors is minimal, the average added power with $V_{IN} = 30\text{ V}$ is around 80 mW at 200 kHz.

Limiting the peak current through the IC is accomplished by placing a resistor between the totem pole output and the gate of the MOSFET. Without this resistor, the peak current is limited only by the dV/dT rate of the totem pole switching and the FET gate capacitance.

An additional discharging diode can be put in parallel with the said limiting resistor to quickly turn off the MOSFET, reducing the switching losses and the control to output delay.

5.7 Typical application

The HVLED002 device can be used as a secondary side step-down current regulator in the multiple staged LED driver - see [Figure 23](#). It is easy to configure the device to drive an inverse (or modified) buck topology based on the fixed off-time (FOT) algorithm.

The MOSFET remains on until the current sense threshold is reached; during the on time, the oscillator remains reset to ground. The current sense threshold is set by the saturation of the E/A to MAXCS to guarantee the higher precision as possible.

The MOSFET is then turned off and the oscillator is released: the resulting off time is fixed by the charging of the CT by RT, connected to VREF.

An optional auxiliary microcontroller, supplied by VREF itself can be used to dim the LED current according to the information sent to the application by a remote controller.

Figure 23. Typical application

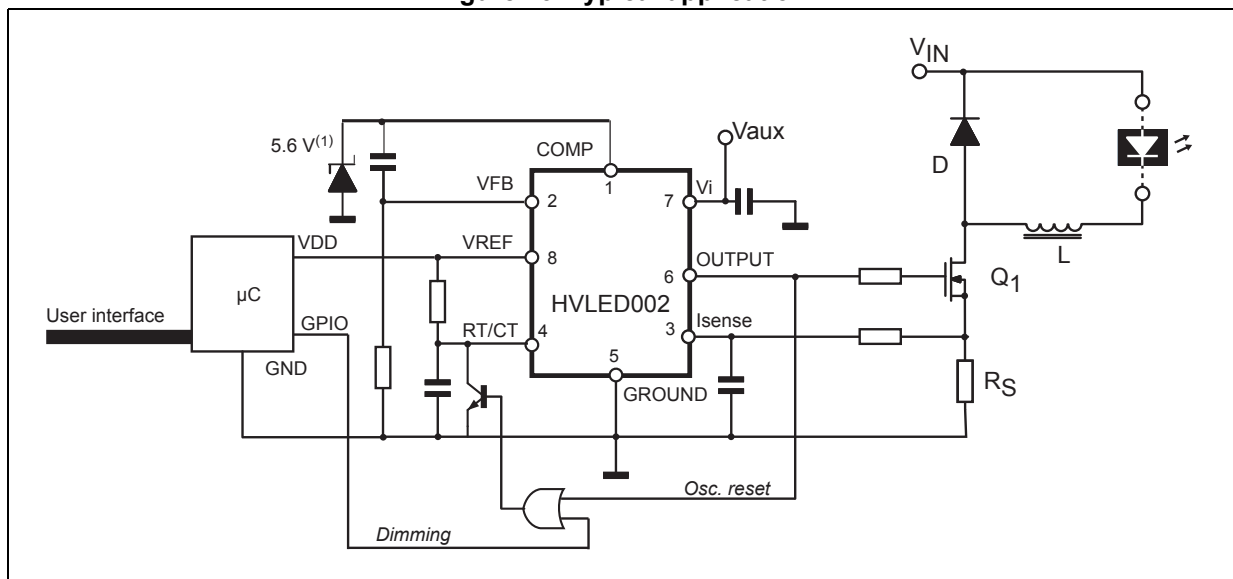

1. Optional for better performances.

6 Package information

In order to meet environmental requirements, ST offers these devices in different grades of ECOPACK® packages, depending on their level of environmental compliance. ECOPACK® specifications, grade definitions and product status are available at: www.st.com. ECOPACK® is an ST trademark.

6.1 SO-8 package information

Figure 24. SO-8 package outline

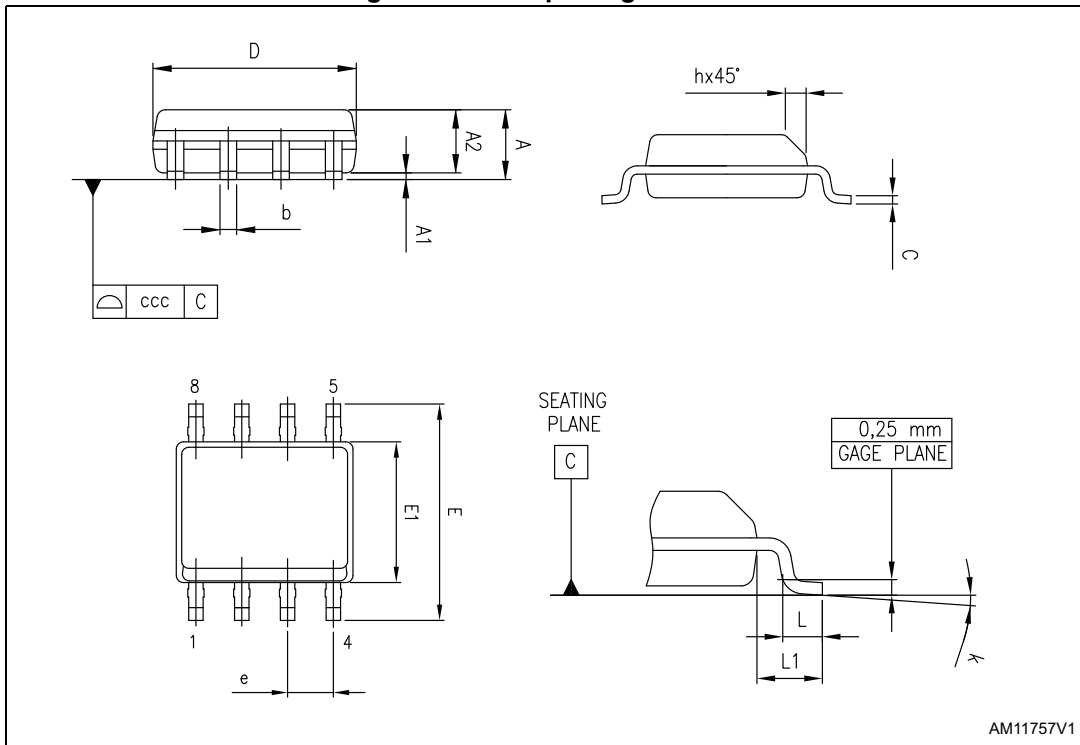

Table 6. SO-8 package mechanical data

Symbol	Dimensions (mm)			Dimensions (inch)		
	Min.	Typ.	Max.	Min.	Typ.	Max.
A			1.750			0.0689
A1	0.100		0.250	0.0039		0.0098
A2	1.250			0.0492		
b	0.280		0.480	0.0110		0.0189
c	0.170		0.230	0.0067		0.0091
D ⁽¹⁾	4.800	4.900	5.000	0.1890	0.1929	0.1969
E	5.800	6.000	6.200	0.2283	0.2362	0.2441
E1 ⁽²⁾	3.800	3.900	4.000	0.1496	0.1535	0.1575
e		1.270			0.0500	
h	0.250		0.500	0.0098		0.0197
L	0.400		1.270	0.0157		0.0500
L1		1.040			0.0409	
k	0°		8°	0°		8°
ccc			0.10			0.0039

1. Dimension "D" does not include mold flash, protrusions or gate burrs. Mold Flash, protrusions or gate burrs shall not exceed 0.15 mm in total (both sides).
2. Dimension "E1" does not include interlead Flash or protrusions. Interlead Flash or protrusions shall not exceed 0.25 mm per side.

7 Revision history

Table 7. Document revision history

Date	Revision	Changes
15-Dec-2015	1	Initial release.

IMPORTANT NOTICE – PLEASE READ CAREFULLY

STMicroelectronics NV and its subsidiaries ("ST") reserve the right to make changes, corrections, enhancements, modifications, and improvements to ST products and/or to this document at any time without notice. Purchasers should obtain the latest relevant information on ST products before placing orders. ST products are sold pursuant to ST's terms and conditions of sale in place at the time of order acknowledgement.

Purchasers are solely responsible for the choice, selection, and use of ST products and ST assumes no liability for application assistance or the design of Purchasers' products.

No license, express or implied, to any intellectual property right is granted by ST herein.

Resale of ST products with provisions different from the information set forth herein shall void any warranty granted by ST for such product.

ST and the ST logo are trademarks of ST. All other product or service names are the property of their respective owners.

Information in this document supersedes and replaces information previously supplied in any prior versions of this document.

© 2015 STMicroelectronics – All rights reserved



X-ON Electronics

Largest Supplier of Electrical and Electronic Components

Click to view similar products for [LED Lighting Drivers](#) category:

Click to view products by [STMicroelectronics](#) manufacturer:

Other Similar products are found below :

[LV5235V-MPB-H](#) [MB39C602PNF-G-JNEFE1](#) [MIC2871YMK-T5](#) [AL1676-10BS7-13](#) [AL1676-20AS7-13](#) [AP5726WUG-7](#) [ICL8201](#)
[IS31BL3228B-UTLS2-TR](#) [IS31BL3506B-TTLS2-TR](#) [AL3157F-7](#) [LV52204MTTBG](#) [AP5725WUG-7](#) [STP4CMPQTR](#) [NCL30086BDR2G](#)
[CAT4004BHU2-GT3](#) [LV52207AXA-VH](#) [AP1694AS-13](#) [TLE4242EJ](#) [AS3688](#) [IS31LT3172-GRLS4-TR](#) [TLD2311EL](#) [KTD2694EDQ-TR](#)
[KTZ8864EJAA-TR](#) [IS32LT3174-GRLA3-TR](#) [MP2488DN-LF-Z](#) [NLM0010XTSA1](#) [AL1676-20BS7-13](#) [ZXLD1370QESTTC](#) [MPQ7220GF-](#)
[AEC1-P](#) [MPQ7220GR-AEC1-P](#) [MPQ4425BGJ-AEC1-P](#) [MPQ7220GF-AEC1-Z](#) [MPQ7220GR-AEC1-Z](#) [MPQ4425BGJ-AEC1-Z](#)
[IS31FL3737B-QFLS4-TR](#) [IS31FL3239-QFLS4-TR](#) [KTD2058EUAC-TR](#) [KTD2037EWE-TR](#) [DIO5662ST6](#) [IS31BL3508A-TTLS2-TR](#)
[KTD2026BEWE-TR](#) [MAX20052CATC/V+](#) [MAX25606AUP/V+](#) [BD6586MUV-E2](#) [BD9206EFV-E2](#) [LYT4227E](#) [LYT6079C-TL](#)
[MP3394SGF-P](#) [MP4689AGN-P](#) [MPQ4425AGQB-AEC1-Z](#)