

Negative voltage regulators

Datasheet - production data

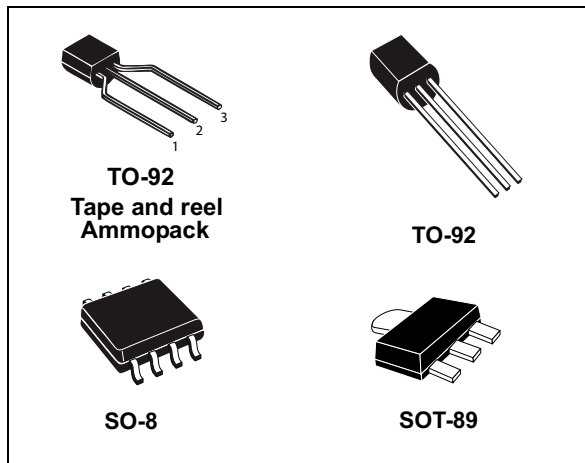

Description

The L79L series of three-terminal negative regulators employ internal current limiting and thermal shutdown, making them essentially indestructible. If adequate heat-sink is provided, they can deliver up to 100 mA output current. They are intended as fixed voltage regulators in a wide range of applications including local or on-card regulation for elimination of noise and distribution problems associated with single-point regulation. In addition, they can be used with power pass elements to make high-current voltage regulators. The L79L series used as Zener diode/resistor combination replacement, offers an effective output impedance improvement of typically two orders of magnitude, along with lower quiescent current and lower noise.

Features

- Output current up to 100 mA
- Output voltages of -5; -8; -12; -15 V
- Thermal overload protection
- Short-circuit protection
- No external components are required
- Available in $\pm 5\%$ (AC) or $\pm 10\%$ (C) selection

Contents

1	Diagram	3
2	Pin configuration	4
3	Maximum ratings	5
4	Electrical characteristics	6
4.1	TO-92	10
4.2	SO-8	11
4.3	SOT-89	14
5	Packaging mechanical data	17
5.1	Tape and reel for TO-92	17
5.2	Tape and reel for TO-92 Ammopak	19
5.3	Tape and reel for SOT-89	21
5.4	Tape and reel for SO-8	22
6	Order codes	24
7	Revision history	25

1 Diagram

Figure 1. Schematic diagram

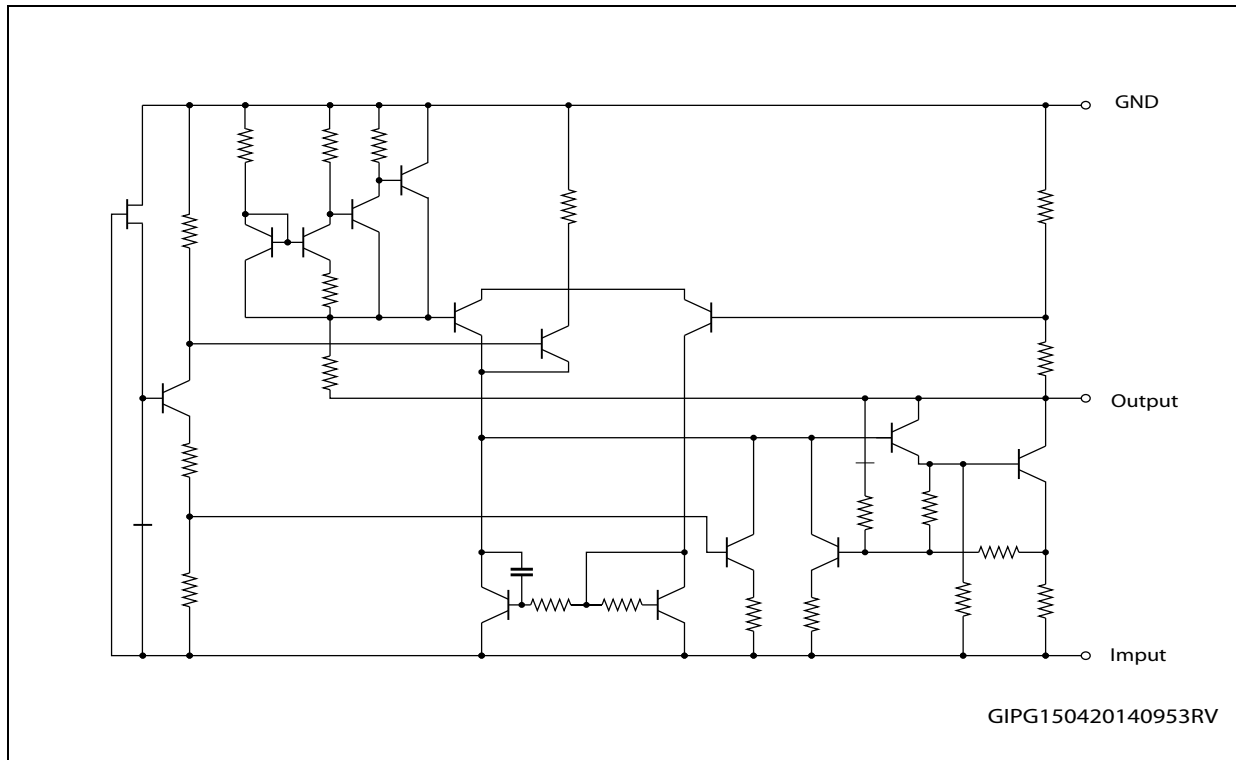

2 Pin configuration

Figure 2. Pin connection (top view, bottom view for TO-92)

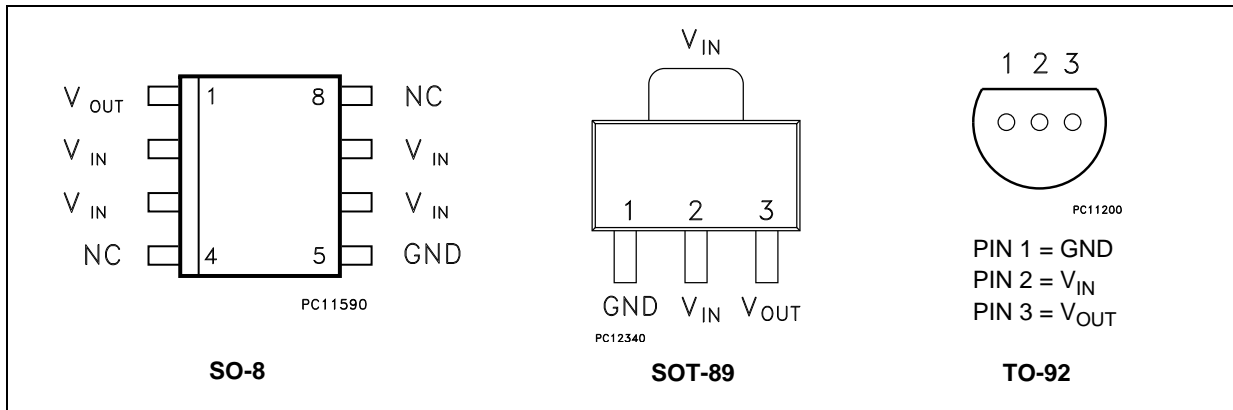
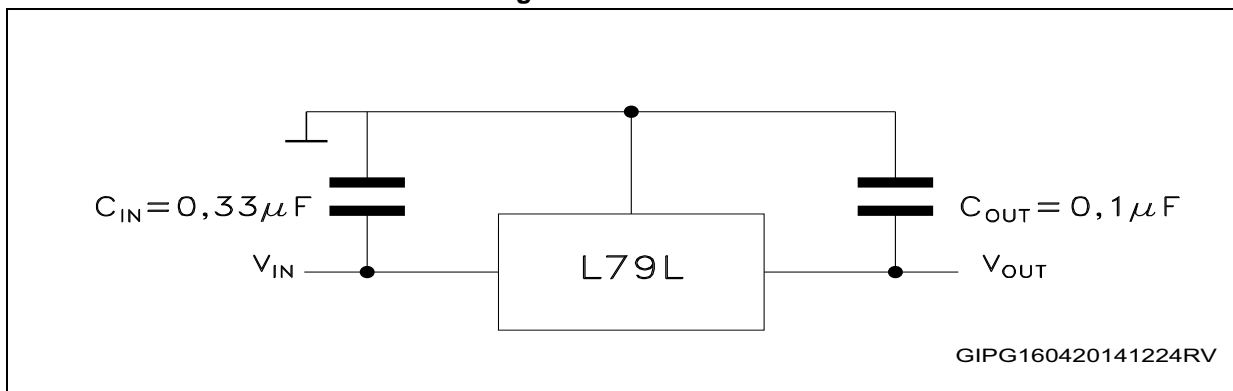

Figure 3. Test circuit



3 Maximum ratings

Table 1. Absolute maximum ratings

Symbol	Parameter	Value	Unit	
V _I	DC input voltage	V _O = -5 to -9 V	-30	V
		V _O = -12 to -15 V	-35	
I _O	Output current	100	mA	
P _D	Power dissipation	Internally limited ⁽¹⁾	mW	
T _{STG}	Storage temperature range	-40 to 150	°C	
T _{OP}	Operating junction temperature range	For L79LXXAC	0 to 125	°C
		For L79LXXAB	-40 to 125	

1. Our SO-8 package used for Voltage Regulators is modified internally to have pins 2, 3, 6 and 7 electrically communed to the die attach flag. This particular frame decreases the total thermal resistance of the package and increases its ability to dissipate power when an appropriate area of copper on the printed circuit board is available for heat-sinking. The external dimensions are the same as for the standard SO-8.

Table 2. Thermal data

Symbol	Parameter	SO-8	TO-92	SOT-89	Unit
R _{thJC}	Thermal resistance junction-case. (Max)	20		15	°C/W
R _{thJA}	Thermal resistance junction-ambient. (Max)	55 ⁽¹⁾	200	115	°C/W

1. Considering 6 cm² of copper Board heat-sink.

4 Electrical characteristics

Refer to the test circuits, $V_I = -10\text{ V}$, $I_O = 40\text{ mA}$, $C_I = 0.33\text{ }\mu\text{F}$, $C_O = 0.1\text{ }\mu\text{F}$, $T_J = 0\text{ to }125\text{ }^\circ\text{C}$ for L79L05AC, $T_J = -40\text{ to }125\text{ }^\circ\text{C}$ for L79L05AB, unless otherwise specified.

Table 3. Electrical characteristics of L79L05AC and L79L05AB

Symbol	Parameter	Test conditions	Min.	Typ.	Max.	Unit
V_O	Output voltage	$T_J = 25^\circ\text{C}$	-4.8	-5	-5.2	V
V_O	Output voltage	$I_O = 1\text{ to }40\text{ mA}$, $V_I = -7\text{ to }-20\text{ V}$	-4.75		-5.25	V
		$I_O = 1\text{ to }70\text{ mA}$, $V_I = -10\text{ V}$	-4.75		-5.25	
DV_O	Line regulation	$V_I = -7\text{ to }-20\text{ V}$, $T_J = 25^\circ\text{C}$			150	mV
		$V_I = -8\text{ to }-20\text{ V}$, $T_J = 25^\circ\text{C}$			100	
DV_O	Load regulation	$I_O = 1\text{ to }100\text{ mA}$, $T_J = 25^\circ\text{C}$			60	mV
		$I_O = 1\text{ to }40\text{ mA}$, $T_J = 25^\circ\text{C}$			30	
I_d	Quiescent current	$T_J = 25^\circ\text{C}$			6	mA
		$T_J = 125^\circ\text{C}$			5.5	mA
DI_d	Quiescent current change	$I_O = 1\text{ to }40\text{ mA}$			0.1	mA
		$V_I = -8\text{ to }-20\text{ V}$			1.5	
eN	Output noise voltage	$B = 10\text{ Hz to }100\text{ kHz}$, $T_J = 25^\circ\text{C}$		40		μV
SVR	Supply voltage rejection	$V_I = -8\text{ to }-18\text{ V}$, $f = 120\text{ Hz}$, $I_O = 40\text{ mA}$, $T_J = 25^\circ\text{C}$	41	49		dB
V_d	Dropout voltage			1.7		V

Refer to the test circuits, $V_I = -14$ V, $I_O = 40$ mA, $C_I = 0.33$ μ F, $C_O = 0.1$ μ F, $T_J = 0$ to 125 °C for L79L08AC $T_J = -40$ to 125 °C for L79L08AB, unless otherwise specified.

Table 4. Electrical characteristics of L79L08AC and L79L08AB

Symbol	Parameter	Test conditions	Min.	Typ.	Max.	Unit
V_O	Output voltage	$T_J = 25^\circ\text{C}$	-7.68	-8	-8.32	V
V_O	Output voltage	$I_O = 1$ to 40 mA, $V_I = -10.5$ to -23 V	-7.6		-8.4	V
		$I_O = 1$ to 70 mA, $V_I = -14$ V	-7.6		-8.4	
DV_O	Line regulation	$V_I = -10.5$ to -23 V, $T_J = 25^\circ\text{C}$			175	mV
		$V_I = -11$ to -23 V, $T_J = 25^\circ\text{C}$			125	
DV_O	Load regulation	$I_O = 1$ to 100 mA, $T_J = 25^\circ\text{C}$			80	mV
		$I_O = 1$ to 40 mA, $T_J = 25^\circ\text{C}$			40	
I_d	Quiescent current	$T_J = 25^\circ\text{C}$			6	mA
		$T_J = 125^\circ\text{C}$			5.5	mA
DI_d	Quiescent current change	$I_O = 1$ to 40 mA			0.1	mA
		$V_I = -11$ to -23 V			1.5	
eN	Output noise voltage	$B = 10$ Hz to 100 kHz, $T_J = 25^\circ\text{C}$		60		μ V
SVR	Supply voltage rejection	$V_I = -12$ to -23 V, $f = 120$ Hz, $I_O = 40$ mA, $T_J = 25^\circ\text{C}$	37	45		dB
V_d	Dropout voltage			1.7		V

Refer to the test circuits, $V_I = -19\text{ V}$, $I_O = 40\text{ mA}$, $C_I = 0.33\text{ }\mu\text{F}$, $C_O = 0.1\text{ }\mu\text{F}$, $T_J = 0\text{ to }125\text{ }^\circ\text{C}$ for L79L12AC, $T_J = -40\text{ to }125\text{ }^\circ\text{C}$ for L79L12AB, unless otherwise specified.

Table 5. Electrical characteristics of L79L12AC and L79L12AB

Symbol	Parameter	Test conditions	Min.	Typ.	Max.	Unit
V_O	Output voltage	$T_J = 25^\circ\text{C}$	-11.5	-12	-12.5	V
V_O	Output voltage	$I_O = 1\text{ to }40\text{ mA}$, $V_I = -14.5\text{ to }-27\text{ V}$	-11.4		-12.6	V
		$I_O = 1\text{ to }70\text{ mA}$, $V_I = -19\text{ V}$	-11.4		-12.6	
DV_O	Line regulation	$V_I = -14.5\text{ to }-27\text{ V}$, $T_J = 25^\circ\text{C}$			250	mV
		$V_I = -16\text{ to }-27\text{ V}$, $T_J = 25^\circ\text{C}$			200	
DV_O	Load regulation	$I_O = 1\text{ to }100\text{ mA}$, $T_J = 25^\circ\text{C}$			100	mV
		$I_O = 1\text{ to }40\text{ mA}$, $T_J = 25^\circ\text{C}$			50	
I_d	Quiescent current	$T_J = 25^\circ\text{C}$			6.5	mA
		$T_J = 125^\circ\text{C}$			6	mA
DI_d	Quiescent current change	$I_O = 1\text{ to }40\text{ mA}$			0.1	mA
		$V_I = -16\text{ to }-27\text{ V}$			1.5	
eN	Output noise voltage	$B = 10\text{ Hz to }100\text{ kHz}$, $T_J = 25^\circ\text{C}$		80		μV
SVR	Supply voltage rejection	$V_I = -15\text{ to }-25\text{ V}$, $f = 120\text{ Hz}$, $I_O = 40\text{ mA}$, $T_J = 25^\circ\text{C}$	37	42		dB
V_d	Dropout voltage			1.7		V

Refer to the test circuits, $V_I = -23\text{ V}$, $I_O = 40\text{ mA}$, $C_I = 0.33\text{ }\mu\text{F}$, $C_O = 0.1\text{ }\mu\text{F}$, $T_J = 0\text{ to }125\text{ }^\circ\text{C}$ for L79L15AC, $T_J = -40\text{ to }125\text{ }^\circ\text{C}$ for L79L15AB, unless otherwise specified.

Table 6. Electrical characteristics of L79L15AC and L79L15AB

Symbol	Parameter	Test conditions	Min.	Typ.	Max.	Unit
V_O	Output voltage	$T_J = 25^\circ\text{C}$	-14.4	-15	-15.6	V
V_O	Output voltage	$I_O = 1\text{ to }40\text{ mA}$, $V_I = -17.5\text{ to }-30\text{ V}$	-14.25		-15.75	V
		$I_O = 1\text{ to }70\text{ mA}$, $V_I = -23\text{ V}$	-14.25		-15.75	
DV_O	Line regulation	$V_I = -17.5\text{ to }-30\text{ V}$, $T_J = 25^\circ\text{C}$			300	mV
		$V_I = -20\text{ to }-30\text{ V}$, $T_J = 25^\circ\text{C}$			250	
DV_O	Load regulation	$I_O = 1\text{ to }100\text{ mA}$, $T_J = 25^\circ\text{C}$			150	mV
		$I_O = 1\text{ to }40\text{ mA}$, $T_J = 25^\circ\text{C}$			75	
I_d	Quiescent current	$T_J = 25^\circ\text{C}$			6.5	mA
		$T_J = 125^\circ\text{C}$			6	mA
DI_d	Quiescent current change	$I_O = 1\text{ to }40\text{ mA}$			0.1	mA
		$V_I = -20\text{ to }-30\text{ V}$			1.5	
eN	Output noise voltage	$B = 10\text{ Hz to }100\text{ kHz}$, $T_J = 25^\circ\text{C}$		90		μV
SVR	Supply voltage rejection	$V_I = -18.5\text{ to }-28.5\text{ V}$, $f = 120\text{ Hz}$ $I_O = 40\text{ mA}$, $T_J = 25^\circ\text{C}$	34	39		dB
V_d	Dropout voltage			1.7		V

4.1 TO-92

Figure 4. TO-92 drawing

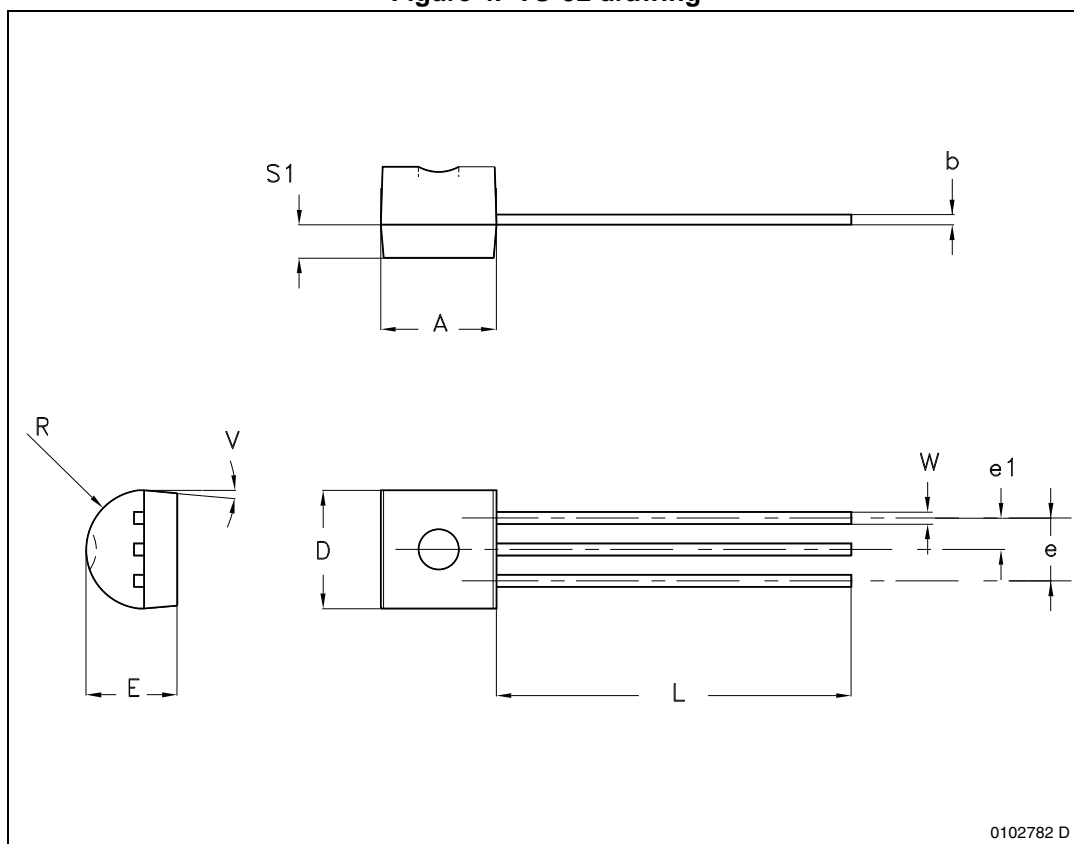

Table 7. TO-92 mechanical data

Dim.	mm		
	Min.	Typ.	Max.
A	4.32		4.95
b	0.36		0.51
D	4.45		4.95
E	3.30		3.94
e	2.41		2.67
e1	1.14		1.40
L	12.70		15.49
R	2.16		2.41
S1	0.92		1.52
W	0.41		0.56
V		5°	

4.2 SO-8

Figure 5. SO-8 drawing

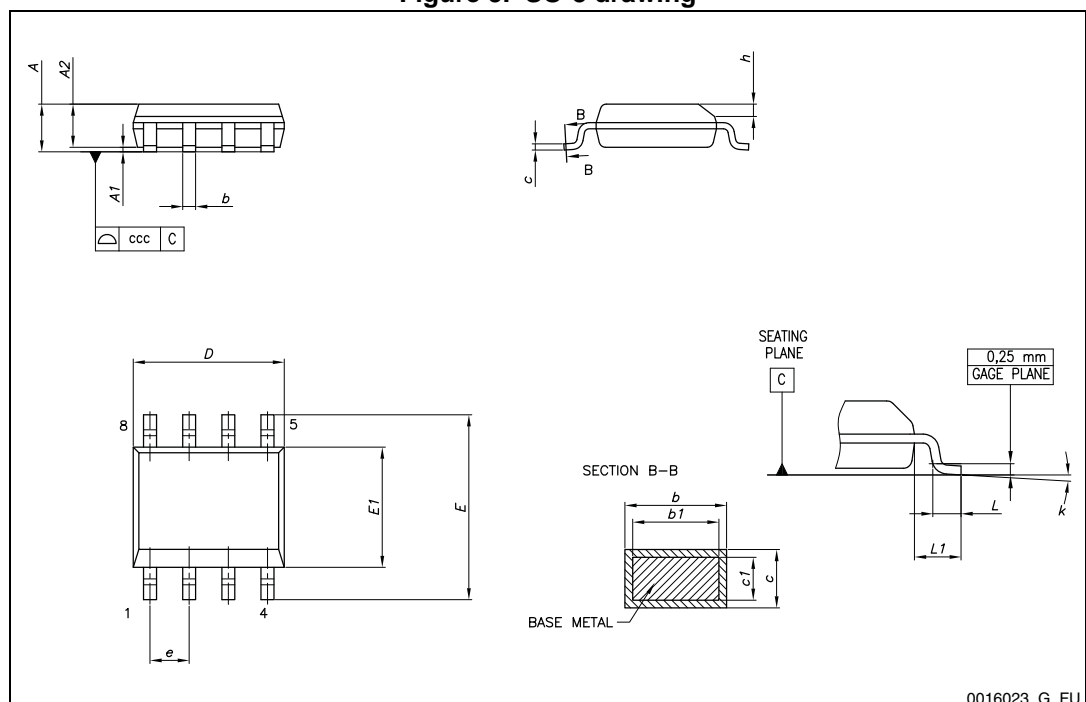
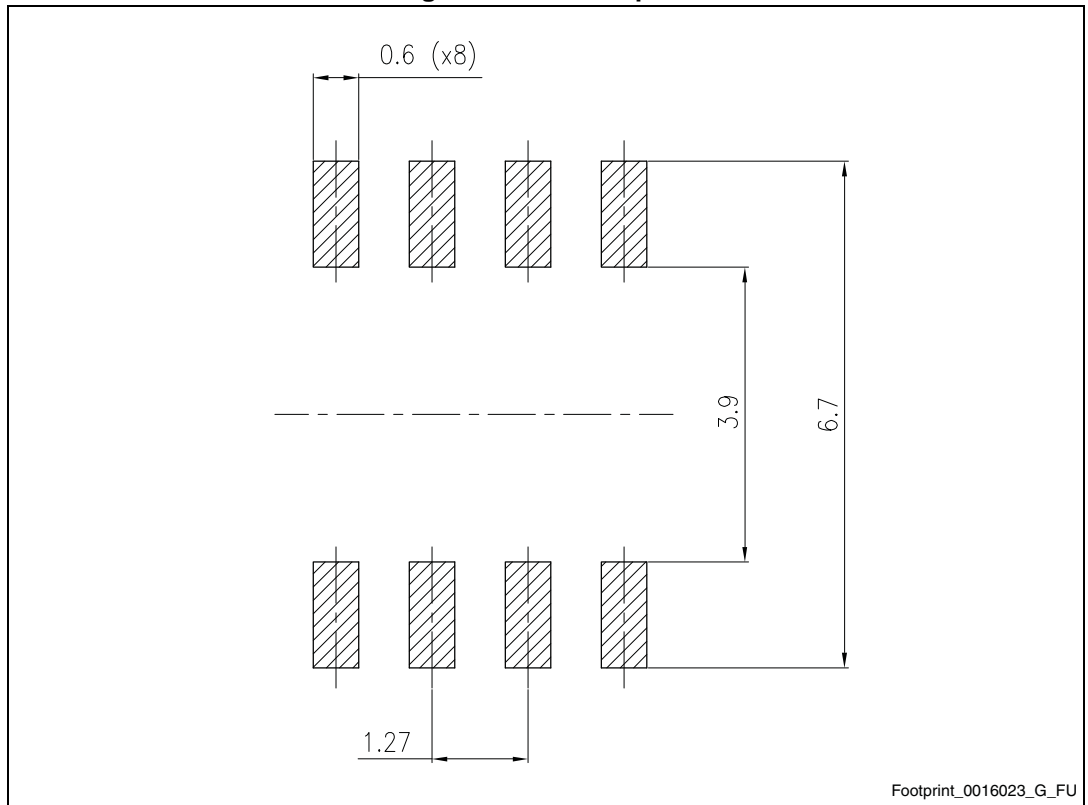

Table 8. SO-8 mechanical data

Dim.	mm		
	Min.	Typ.	Max.
A			1.75
A1	0.10		0.25
A2	1.25		
b	0.31		0.51
b1	0.28		0.48
c	0.10		0.25
c1	0.10		0.23
D	4.80	4.90	5.00
E	5.80	6.00	6.20
E1	3.80	3.90	4.00
e		1.27	
h	0.25		0.50
L	0.40		1.27
L1		1.04	
L2		0.25	
k	0°		8°
ccc			0.10

Figure 6. SO-8 footprint



4.3 SOT-89

Figure 7. SOT-89 drawing

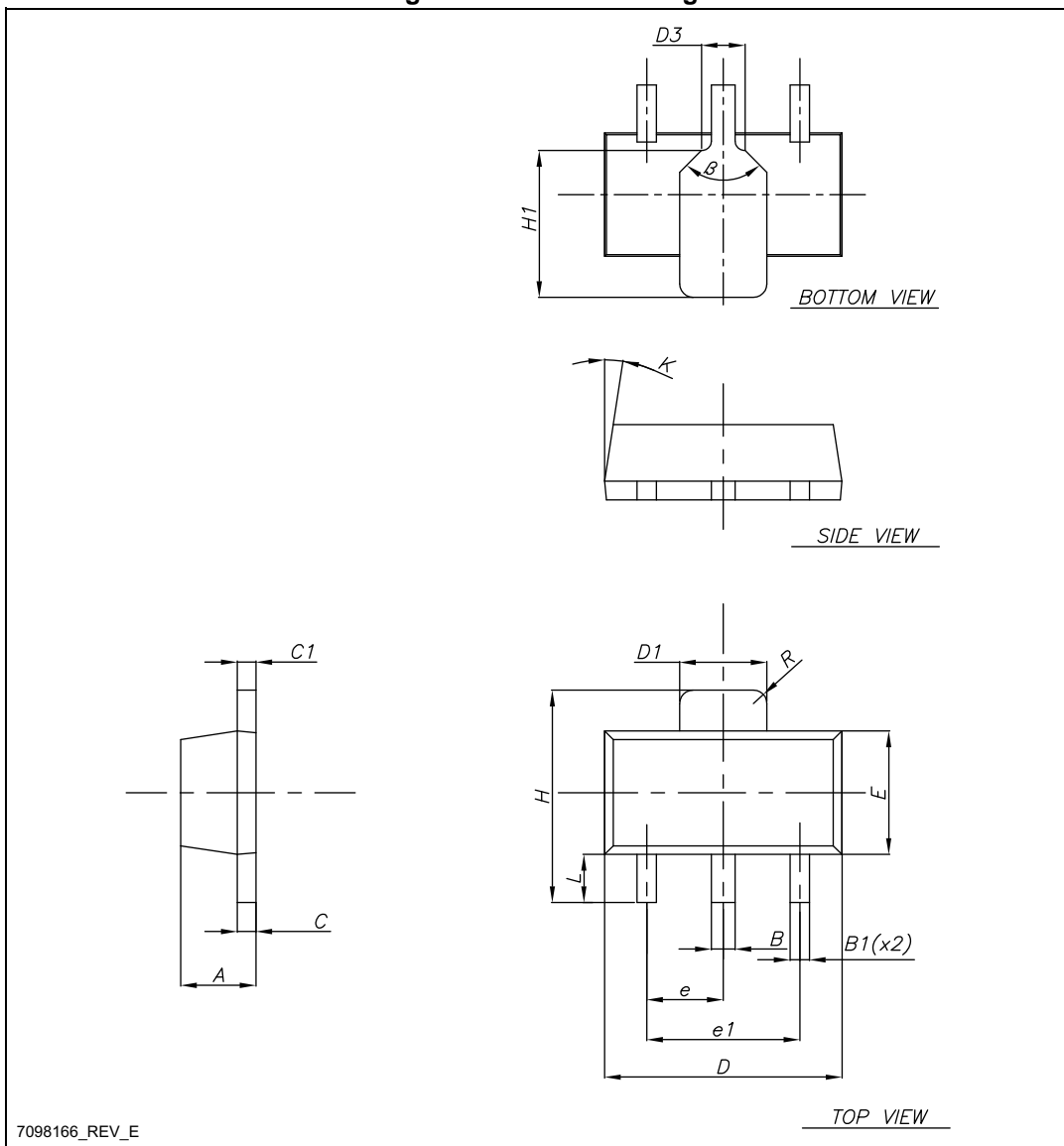
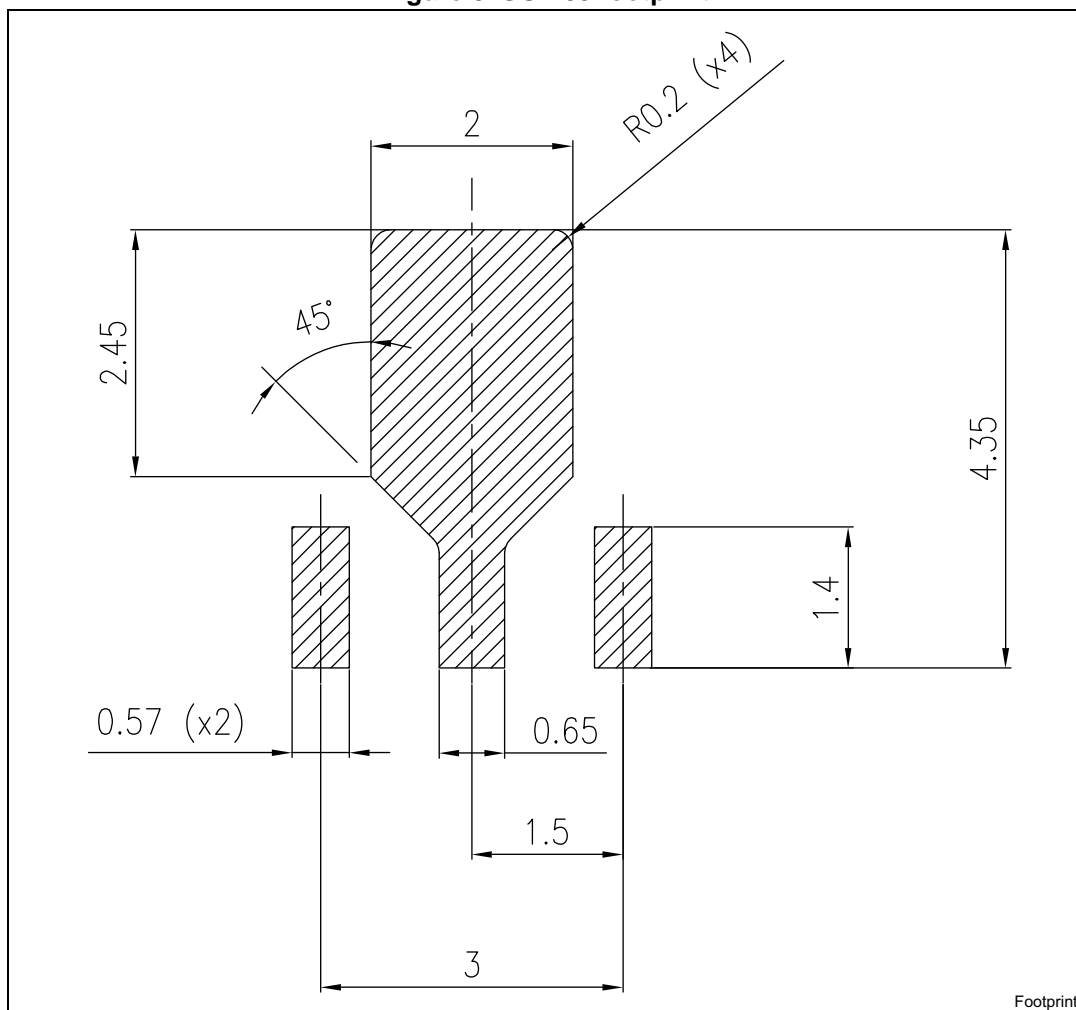

Table 9. SOT-89 mechanical data

Dim.	mm		
	Min.	Typ.	Max.
A	1.40		1.60
B	0.44		0.56
B1	0.36		0.48
C	0.35		0.44
C1	0.35		0.44
D	4.40		4.60
D1	1.62		1.83
D3		0.90	
E	2.29		2.60
e	1.42		1.57
e1	2.92		3.07
H	3.94		4.25
H1	2.70		3.10
K	1°		8°
L	0.89		1.20
R		0.25	
b		90°	

Figure 8. SOT-89 footprint



5 Packaging mechanical data

5.1 Tape and reel for TO-92

Figure 9. TO-92 tape and reel dimensions

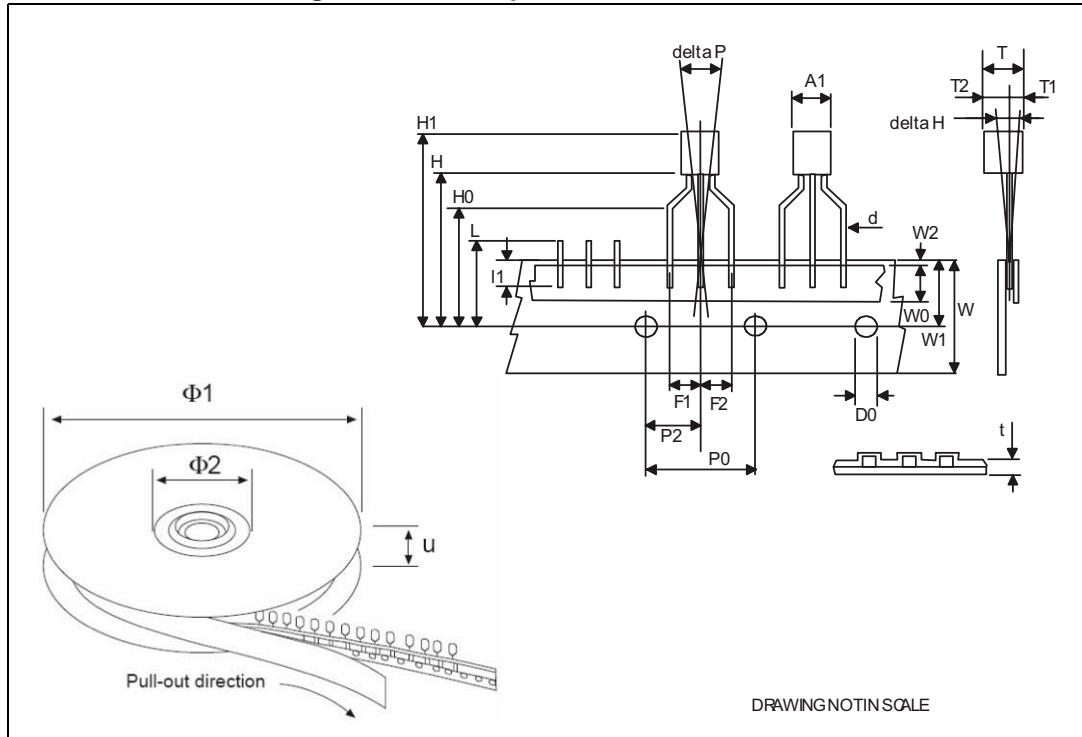

Table 10. TO-92 tape and reel mechanical data

Dim.	mm		
	Min.	Typ.	Max.
A1			4.80
T			3.80
T1			1.60
T2			2.30
d	0.45	0.47	0.48
P0	12.50	12.70	12.90
P2	5.65	6.35	7.05
F1, F2	2.40	2.50	2.94
F3	4.98	5.08	5.48
delta H	-2.00		2.00
W	17.50	18.00	19.00
W0	5.5	6.00	6.5
W1	8.50	9.00	9.25
W2			0.50
H		18.50	21
H3	0.5	1	2
H0	15.50	16.00	18.8
H1		25.0	27.0
D0	3.80	4.00	4.20
t			0.90
L			11.00
l1	3.00		
delta P	-1.00		1.00
Ø1	352	355	358
Ø2	28	30	32
u	44	47	50

5.2 Tape and reel for TO-92 Ammopak

Figure 10. TO-92 Ammopak

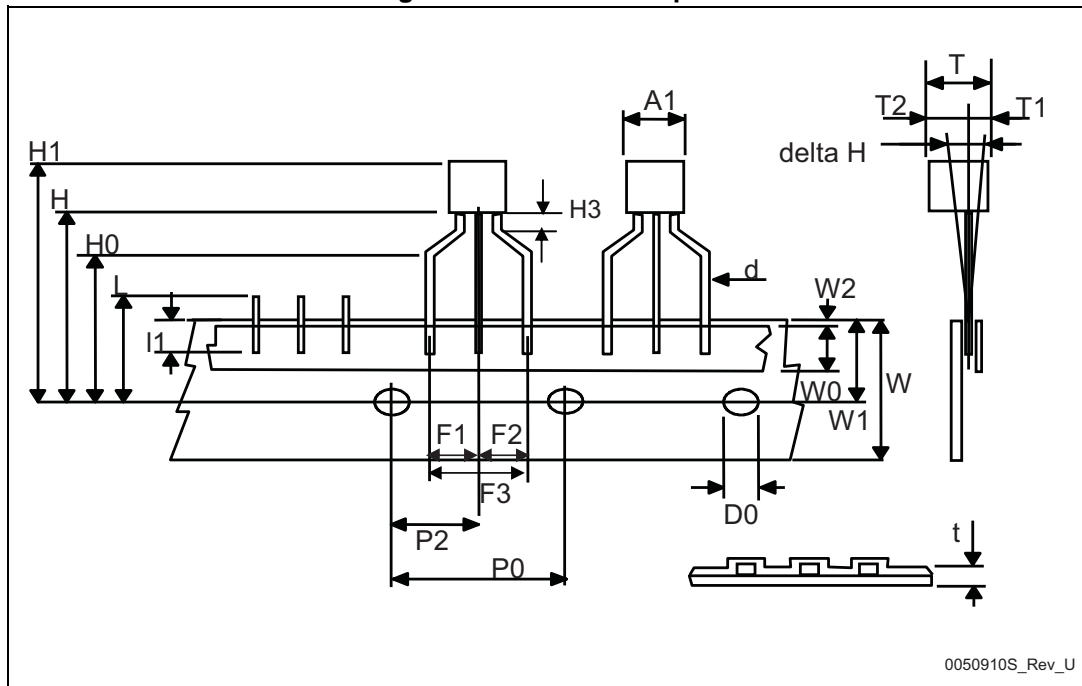

Table 11. TO-92 Ammopak mechanical data

Dim.	mm		
	Min.	Typ.	Max.
A1			4.80
T			3.80
T1			1.60
T2			2.30
d	0.45	0.47	0.48
P0	12.50	12.70	12.90
P2	5.65	6.35	7.05
F1, F2	2.40	2.50	2.94
F3	4.98	5.08	5.48
delta H	-2.00		2.00
W	17.50	18.00	19.00
W0	5.5	6.00	6.5
W1	8.50	9.00	9.25
W2			0.50
H		18.50	21
H3	0.5	1	2
H0	15.50	16.00	18.8
H1		25.0	27.0
D0	3.80	4.00	4.20
t			0.90
L			11.00
l1	3.00		
delta P	-1.00		1.00

5.3 Tape and reel for SOT-89

Figure 11. SOT-89 carrier tape drawing

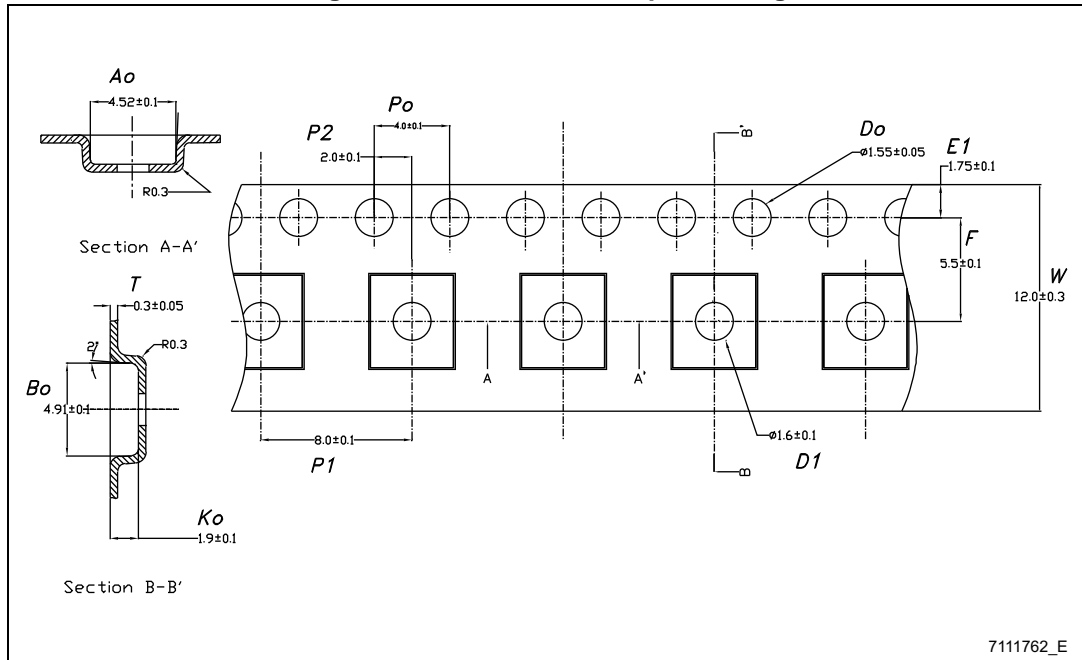

Table 12. SOT-89 carrier tape dimensions

Dim.	mm.	
	Values	Tolerance
Ao	4.52	± 0.10
Bo	4.91	± 0.10
Ko	1.90	± 0.10
F	5.50	± 0.10
E	1.75	± 0.10
W	12	± 0.30
P2	2	± 0.10
Po	4	± 0.10
P1	8	± 0.10
T	0.30	± 0.10
D	$\varnothing 1.55$	± 0.05
D1	$\varnothing 1.60$	± 0.10

5.4 Tape and reel for SO-8

Figure 12. SO-8 tape and reel dimensions

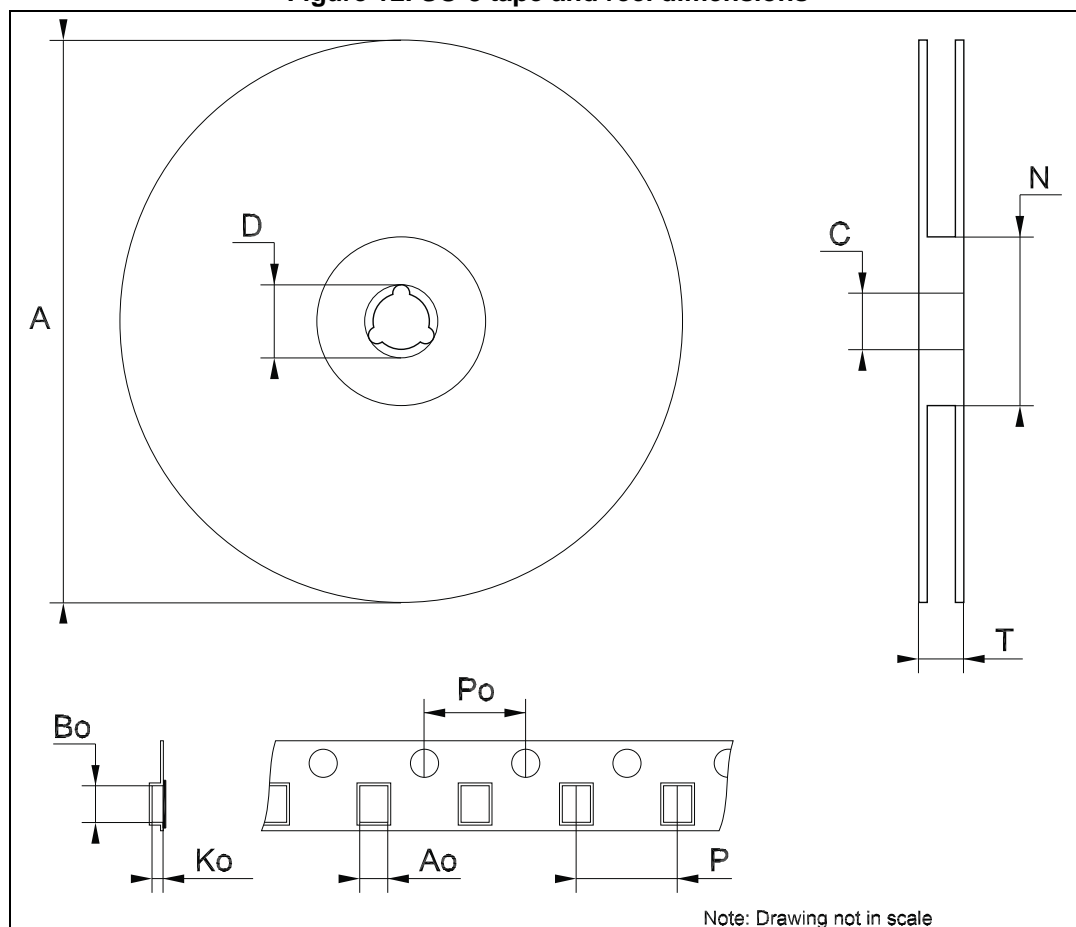

Table 13. SO-8 tape and reel mechanical data

Dim.	Min.	Typ.	Max.
A			330
C	12.8		13.2
D	20.2		
N	60		
T			22.4
Ao	8.1		8.5
Bo	5.5		5.9
Ko	2.1		2.3
Po	3.9		4.1
P	7.9		8.1

6 Order codes

Table 14. Order codes

SO-8	TO-92 (bag)	TO-92 (Ammopak)	TO-92 (tape and reel)	SOT89	Output voltage
L79L05ABD13TR	L79L05ACZ	L79L05ABZ-AP		L79L05ABUTR	-5V
L79L05ACD13TR		L79L08ACZ-AP	L79L05ACZ-TR	L79L05ACUTR	-5V
L79L08ACD13TR					-8V
L79L12ACD13TR			L79L12ACZ-TR	L79L12ACUTR	-12V
L79L15ABD13TR					-15V
L79L15ACD13TR				L79L15ACUTR	-15V

7 Revision history

Table 15. Document revision history

Date	Revision	Changes
14-Mar-2005	9	Add Tape and Reel for TO-92.
15-Mar-2005	10	Add note on Table 3.
23-Dec-2005	11	Mistake on ordering Table in Header.
12-Sep-2006	12	Order codes updated.
25-Jul-2007	13	Pin connection for SOT-89 updated on Figure 2 .
04-Dec-2007	14	Modified: Table 14 .
14-Jul-2008	15	Modified: Table 14 on page 24 .
29-Jul-2009	16	Modified: Table 14 on page 24 .
17-Apr-2014	17	Part numbers L79LxxAB, L78LxxAC, L78LxxC changed to L79L. Removed Table 1: Device summary. Updated the features and description in cover page. Updated Figure 1: Schematic diagram , Table 1: Absolute maximum ratings and Table 14: Order codes . Added Section 5: Packaging mechanical data . Minor text changes.

Please Read Carefully:

Information in this document is provided solely in connection with ST products. STMicroelectronics NV and its subsidiaries ("ST") reserve the right to make changes, corrections, modifications or improvements, to this document, and the products and services described herein at any time, without notice.

All ST products are sold pursuant to ST's terms and conditions of sale.

Purchasers are solely responsible for the choice, selection and use of the ST products and services described herein, and ST assumes no liability whatsoever relating to the choice, selection or use of the ST products and services described herein.

No license, express or implied, by estoppel or otherwise, to any intellectual property rights is granted under this document. If any part of this document refers to any third party products or services it shall not be deemed a license grant by ST for the use of such third party products or services, or any intellectual property contained therein or considered as a warranty covering the use in any manner whatsoever of such third party products or services or any intellectual property contained therein.

UNLESS OTHERWISE SET FORTH IN ST'S TERMS AND CONDITIONS OF SALE ST DISCLAIMS ANY EXPRESS OR IMPLIED WARRANTY WITH RESPECT TO THE USE AND/OR SALE OF ST PRODUCTS INCLUDING WITHOUT LIMITATION IMPLIED WARRANTIES OF MERCHANTABILITY, FITNESS FOR A PARTICULAR PURPOSE (AND THEIR EQUIVALENTS UNDER THE LAWS OF ANY JURISDICTION), OR INFRINGEMENT OF ANY PATENT, COPYRIGHT OR OTHER INTELLECTUAL PROPERTY RIGHT.

ST PRODUCTS ARE NOT DESIGNED OR AUTHORIZED FOR USE IN: (A) SAFETY CRITICAL APPLICATIONS SUCH AS LIFE SUPPORTING, ACTIVE IMPLANTED DEVICES OR SYSTEMS WITH PRODUCT FUNCTIONAL SAFETY REQUIREMENTS; (B) AERONAUTIC APPLICATIONS; (C) AUTOMOTIVE APPLICATIONS OR ENVIRONMENTS, AND/OR (D) AEROSPACE APPLICATIONS OR ENVIRONMENTS. WHERE ST PRODUCTS ARE NOT DESIGNED FOR SUCH USE, THE PURCHASER SHALL USE PRODUCTS AT PURCHASER'S SOLE RISK, EVEN IF ST HAS BEEN INFORMED IN WRITING OF SUCH USAGE, UNLESS A PRODUCT IS EXPRESSLY DESIGNATED BY ST AS BEING INTENDED FOR "AUTOMOTIVE, AUTOMOTIVE SAFETY OR MEDICAL" INDUSTRY DOMAINS ACCORDING TO ST PRODUCT DESIGN SPECIFICATIONS. PRODUCTS FORMALLY ESCC, QML OR JAN QUALIFIED ARE DEEMED SUITABLE FOR USE IN AEROSPACE BY THE CORRESPONDING GOVERNMENTAL AGENCY.

Resale of ST products with provisions different from the statements and/or technical features set forth in this document shall immediately void any warranty granted by ST for the ST product or service described herein and shall not create or extend in any manner whatsoever, any liability of ST.

ST and the ST logo are trademarks or registered trademarks of ST in various countries.

Information in this document supersedes and replaces all information previously supplied.

The ST logo is a registered trademark of STMicroelectronics. All other names are the property of their respective owners.

© 2014 STMicroelectronics - All rights reserved

STMicroelectronics group of companies

Australia - Belgium - Brazil - Canada - China - Czech Republic - Finland - France - Germany - Hong Kong - India - Israel - Italy - Japan - Malaysia - Malta - Morocco - Philippines - Singapore - Spain - Sweden - Switzerland - United Kingdom - United States of America

www.st.com

X-ON Electronics

Largest Supplier of Electrical and Electronic Components

Click to view similar products for [STMicroelectronics](#) manufacturer:

Other Similar products are found below :

[L6571AD](#) [LD29300D2T25R](#) [M24M02-DWMN3TP/K](#) [AI-JTAGOPTO-1](#) [BZW04-15B](#) [LDK320AM33R](#) [SPC564A80CAL176](#)
[SPC56XVTOP-M](#) [STEVAL-ILL076V2](#) [STEVAL-ISA175V1](#) [STEVAL-VNH5050A](#) [STM32F038C6T6](#) [STM32F207IGT7](#)
[STM32F405VGT6W](#) [STR91X-SK/RAI](#) [STTH12003TV1](#) [STVNIM-EVAL](#) [417989F](#) [SG3525A](#) [SMP100MC-270](#) [STEVAL-ILL079V1](#)
[STEVAL-ISF003V1](#) [STL140N4F7AG](#) [STM32F031F4P7](#) [STM32F071CBU6](#) [STM32PRIM-LABUPG](#) [STM8A128-EVAL](#)
[STM8L152K8Y6TR](#) [STW56N65DM2](#) [LF50ABV](#) [VIPER38HDTR](#) [VIPER27LD](#) [VIPER16HN](#) [PD57070-E](#) [EVAL6226QR](#) [EVAL6227PD](#)
[EVAL6228QR](#) [EVALSP1340HDM](#) [EVLVIP16L-4WFL](#) [EV-VN7050AJ](#) [EV-VND5E025AK](#) [EV-VND7030AJ](#) [ANT2-M24LR16E](#)
[STY60NM50](#) [STW23N85K5](#) [STR736FV2T6](#) [STPS4S200B-TR](#) [STM8L1526-EVAL](#) [STM8/128-SK/RAIS](#) [STM32L152VET6](#)