

## Automotive 4-channel valve driver

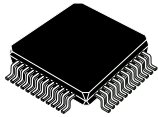

TQFP48 exposed pad down (7x7x1 mm)

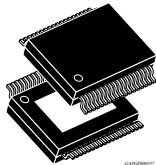

PowerSSO36 exposed pad down

### Features

- AEC-Q100 qualified 
- 4-channel independent LSD/HSD current controlled drivers
  - Integrated current sense path
  - Current accuracy (in normal range)
    - $\pm 5$  mA in 0 to 0.5 A range
    - $\pm 1\%$  in 0.5 A to 1.5 A range
  - Current accuracy (in extended range)
    - $\pm 15$  mA in 0 to 0.3 A range
    - $\pm 5\%$  in 0.3 A to 0.5 A range
    - $\pm 4\%$  in 0.5 A to 2 A range
  - Max driver  $R_{DS(ON)}$  375 m $\Omega$  @ 175 °C
  - 13-bit current set-point resolution
  - Variable and fixed frequency current control
  - Programmable dither function
  - Selectable driver slew rate control
- Safety features
  - High side fail safe ENABLE switch pre-driver with VDS monitoring
  - Redundant safe enable path
  - Advanced diagnosis and monitoring using BIST
  - Temperature sensor and monitoring
  - Redundant current sensing for all channels
  - Calibration & configuration memory including CRC
  - Secure serial communications using address feedback, 5-bit CRC, frame counter & long/short frame detection
  - Register verification
- 32-bit SPI communications with 5-bit CRC message verification
- Package options: PWSSO36, TQFP48
- Full ISO26262 compliant, ASIL-D systems ready

Product status link	
L9305	
Product summary	
Order code	L9305EP
Package	PowerSSO36
Packing	Tube
Order code	L9305EP-TR
Package	PowerSSO36
Packing	Tape and reel
Order code	L9305QFP
Package	TQFP48
Packing	Tray
Order code	L9305QFP-TR
Package	TQFP48
Packing	Tape and reel

### Description

The **L9305** is a configurable, monolithic solenoid driver IC designed for the control of linear solenoids for automatic transmission, electronic stability control, and active suspension applications. The four channels can be configured as either low side or high side drivers in any combination. The device includes the power transistor, recirculation transistor and current sensing for both the power and recirculation transistor. This architecture guarantees redundancy of the current measurement for each channel.

The regulated current is programmable in the range of 0-1.5 A (normal range), with a resolution of 0.25 mA, or 0-2 A (extended range), with a resolution of 0.33 mA. The user can superimpose configurable dither modulation over the set point current.

A 32-bit CRC protected SPI interface is used for configuration and control of all channels and provides status feedback of all diagnostic functions. An active low reset input, RESN, is used to disable all channels and resets internal registers to their default values. A safe enable path is provided through the EN\_DR pin and the integrated Fail Safe Pre-driver. An isolated redundant safety switch-off path ensures that critical internal faults disable the fail safe pre-driver. An active high enable pin, EN\_DR, is used to enable or disable the operation of all channels. When the EN\_DR pin is low, all channels are disabled. A fault output pin is provided and can be used to generate an external interrupt to the microcontroller whenever a fault is detected. The user can map specific faults to the FAULTn pin based on their specific system requirements.

# 1 Block diagram

Figure 1. Block diagram

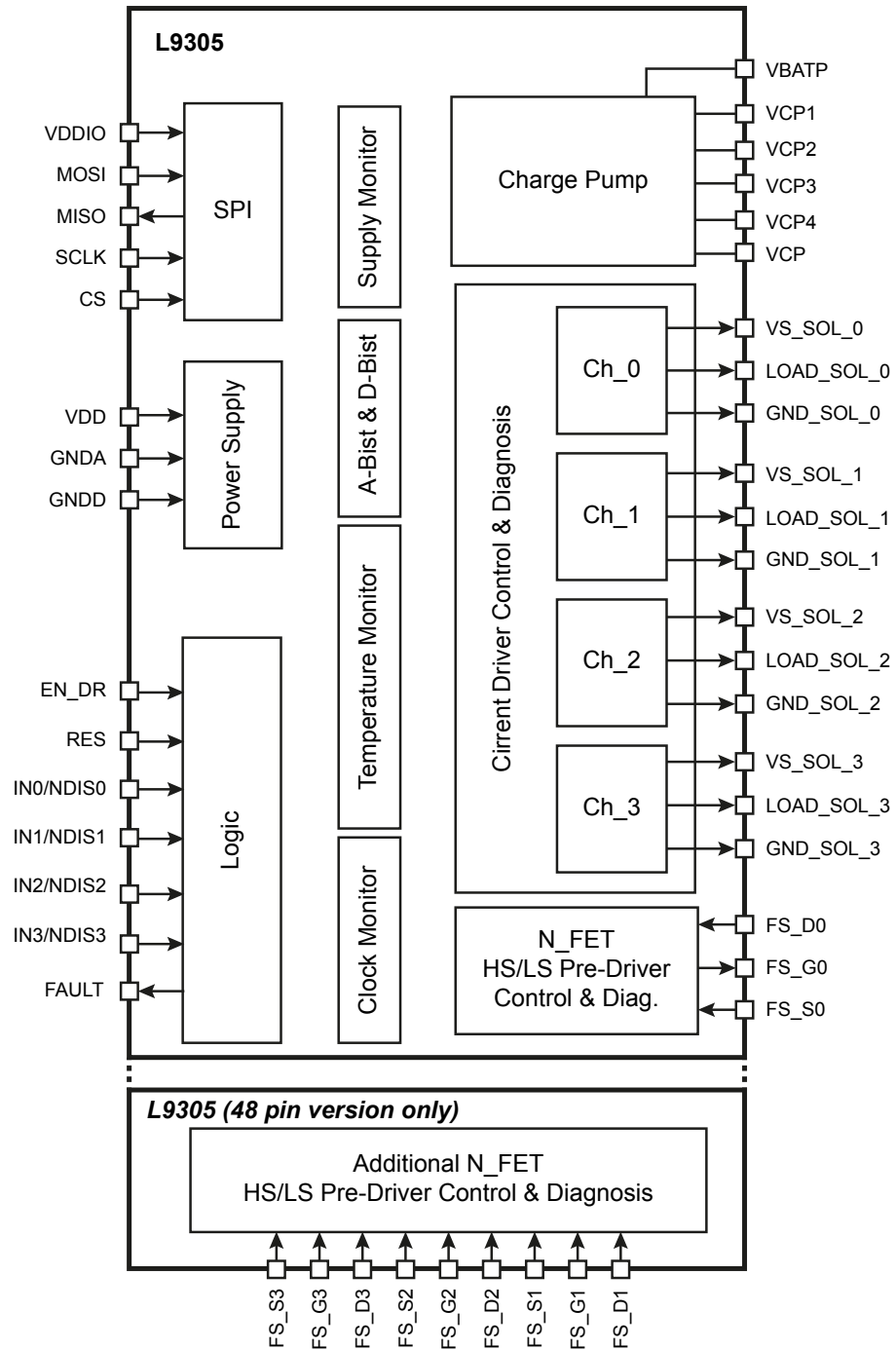

GADG2609181252PS

**Figure 2. PWSSO36 application schematic**

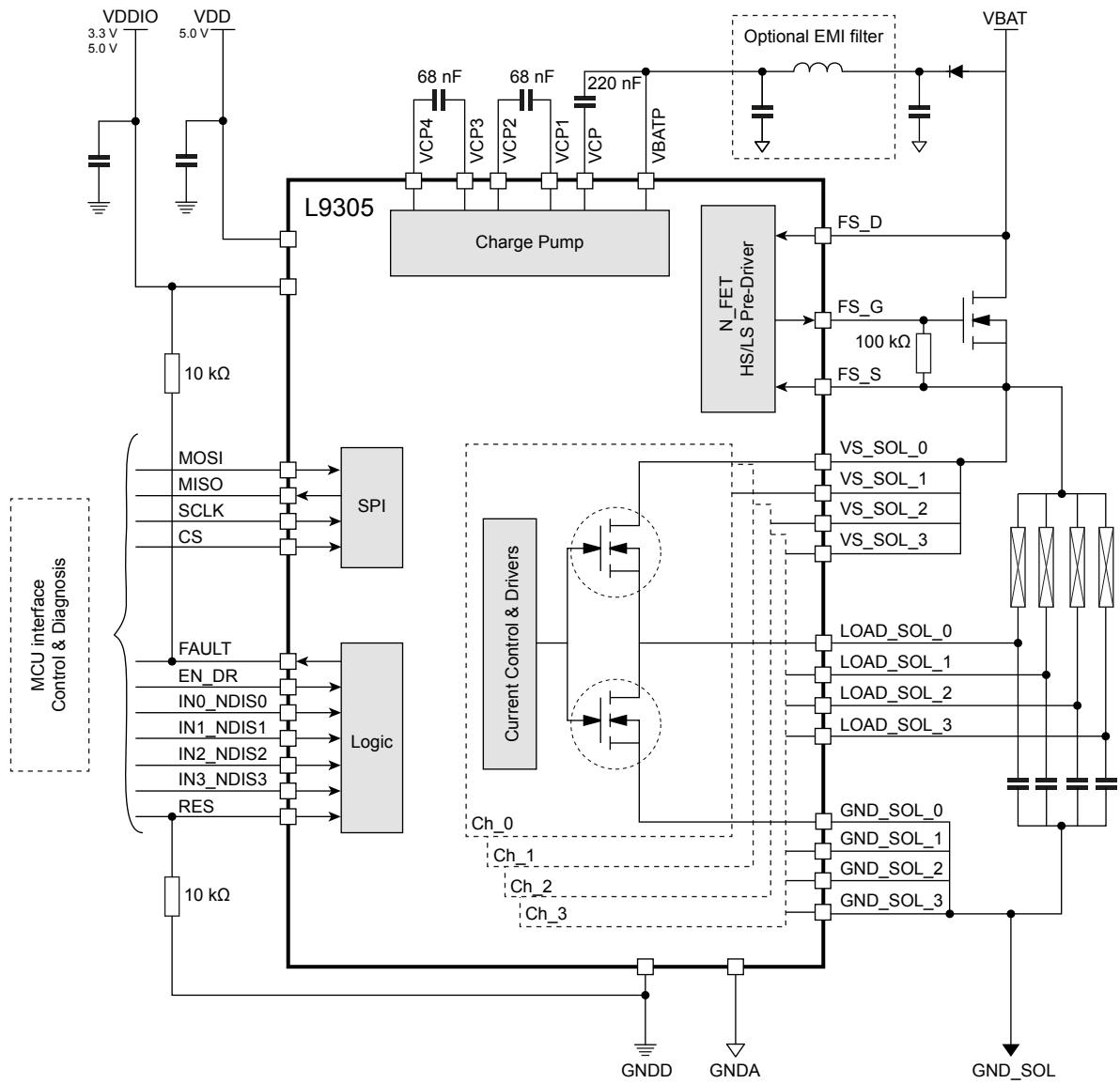

**Figure 3. TQFP48 application schematic**

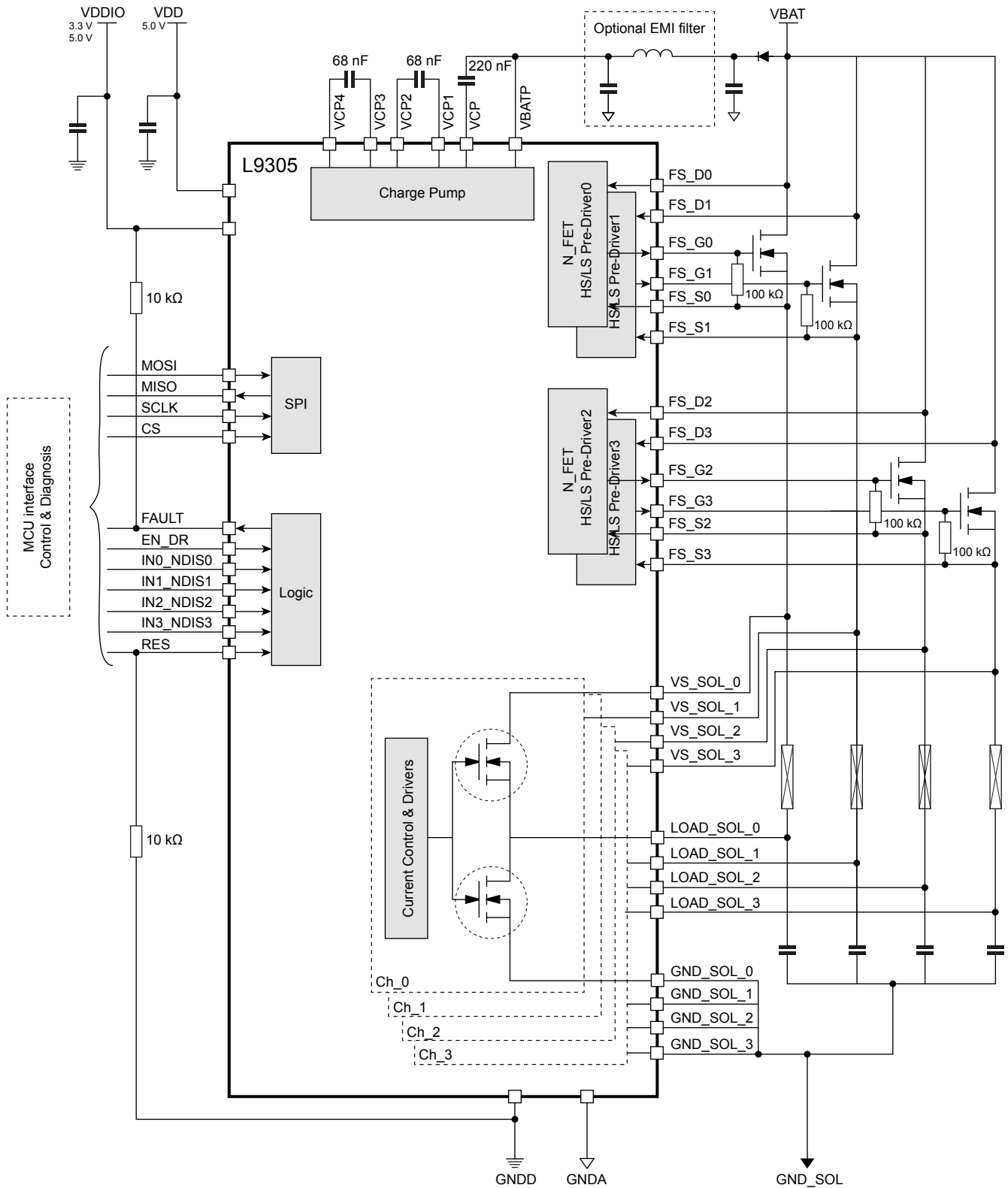

GADG2609181302PS

## 2 Pins description

Figure 4. PowerSSO-36 pinout diagram

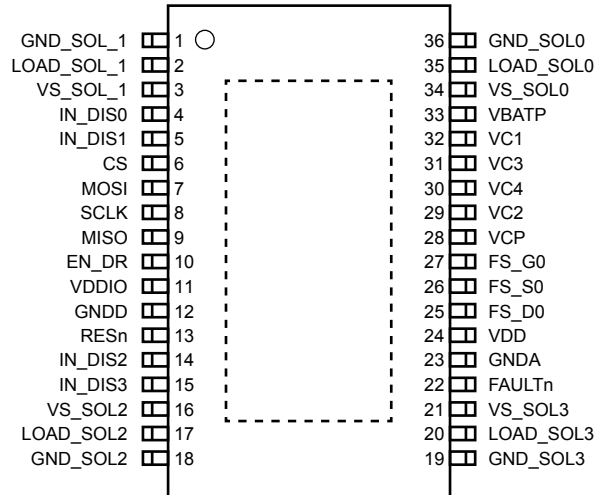
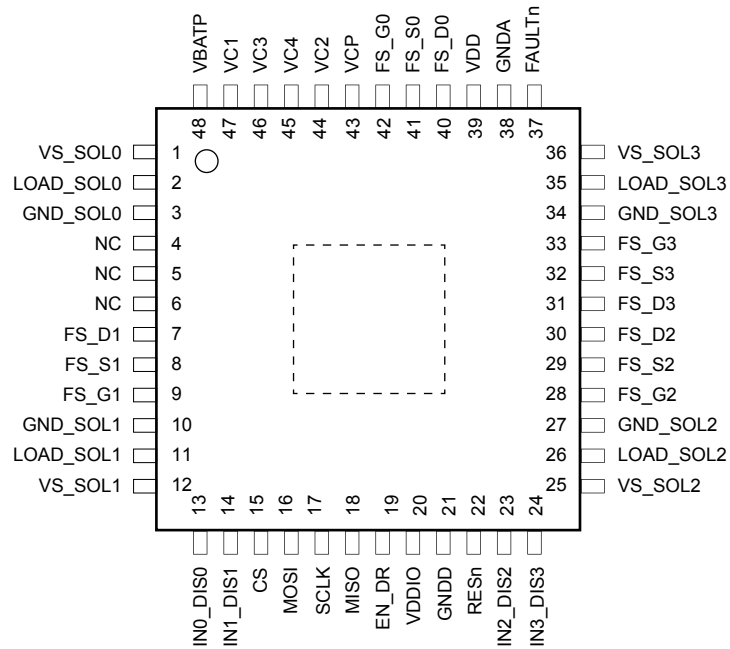

Figure 5. TQFP48 pinout diagram



**Table 1. PowerSSO-36 and TQFP48 pins list**

Pin number PowerSSO-36	Pin number TQFP48	Symbol	Function
1	10	GND_SOL1	Channel 1 Ground: Ground connection for channel 1 power stage.
2	11	LOAD_SOL1	Channel 1 Output
3	12	VS_SOL1	Channel 1 Supply Voltage: Connect to Switched Battery Voltage with reverse protection diode
4	13	IN_DIS0	Parallel Input Channel 0: Input for direct control from external MCU when in SW Mode; Disable channel command when in SW mode
5	14	IN_DIS1	Parallel Input Channel 1: Input for direct control from external MCU when in SW Mode; Disable channel command when in SW mode
6	15	CS	SPI Chip Select Input: SPI communication protocol Chip Select from MCU to the device. Digital logic level: 5.0V or 3.3V
7	16	MOSI	SPI Data Input: SPI communication protocol input from MCU to the device. Digital logic level: 5.0V or 3.3V
8	17	SCLK	SPI Clock Input: SPI communication protocol clock from MCU to the device. Digital logic level: 5.0V or 3.3V
9	18	MISO	SPI Data Output: SPI communication protocol output to MCU from the device. Digital logic level: 5.0V or 3.3V
10	19	EN_DR	Enable Driver:
11	20	VDDIO	IO Supply: To be connected to 5.0V or 3.3V
12	21	GNDD	Digital Ground: Ground for digital circuits
13	22	RESn	Reset: when HIGH, device out of reset, when LOW, device in reset state
14	23	IN_DIS2	Parallel Input Channel 2: Input for direct control from external MCU when in SW Mode; Disable channel command when in SW mode
15	24	IN_DIS3	Parallel Input Channel 3: Input for direct control from external MCU when in SW Mode; Disable channel command when in SW mode
16	25	VS_SOL2	Channel 2 Supply Voltage: Connect to Switched Battery Voltage with reverse protection diode
17	26	LOAD_SOL2	Channel 2 Output
18	27	GND_SOL2	Channel 2 Ground: Ground connection for channel 2 power stage.
19	34	GND_SOL3	Channel 3 Ground: Ground connection for channel 3 power stage.
20	35	LOAD_SOL3	Channel 3 Output
21	36	VS_SOL3	Channel 3 Supply Voltage: Connect to Switched Battery Voltage with reverse protection diode
22	37	FAULTn	Fault: when LOW, Fault present, when HIGH, no fault present
23	38	GNDA	Analog Ground: Ground for analog circuits
24	39	VDD	Supply Voltage: Supply for circuits. Connect to 5.0V supply voltage
25	40	FS_D0	Fail Safe Drain: to be connected to external FET Drain used as FS. VDS monitor
26	41	FS_S0	Fail Safe Source: to be connected to external FET Source used as FS. VDS monitor
27	42	FS_G0	Fail Safe Gate: Gate command for external FET Drain used as FS
28	43	VCP	Charge Pump Voltage: Connected to Protected Battery Voltage through External Capacitor
29	44	VC2	Charge Pump: External Capacitor connection
30	45	VC4	Charge Pump: External Capacitor connection
31	46	VC3	Charge Pump: External Capacitor connection

Pin number PowerSSO-36	Pin number TQFP48	Symbol	Function
32	47	VC1	Charge Pump: External Capacitor connection
33	48	VBATP	Supply Voltage: Connected to Protected Battery Voltage (reverse protection diode and filter against EMC)
34	1	VS_SOL0	Channel 0 Supply Voltage: Connect to Switched Battery Voltage with reverse protection diode
35	2	LOAD_SOL0	Channel 0 Output
36	3	GND_SOL0	Channel 0 Ground: Ground connection for channel 0 power stage.
–	–	–	Available on TQFP-48 version only
–	9	FS_G_1	Fail Safe Gate: Gate command for external FET Drain used as FS
–	8	FS_S_1	Fail Safe Source: to be connected to external FET Source used as FS. VDS monitor
–	7	FS_D_1	Fail Safe Drain: to be connected to external FET Drain used as FS. VDS monitor
–	6	NC	Not Used: To be connected to GND.
–	5	NC	Not Used: To be connected to GND.
–	4	NC	Not Used: To be connected to GND.
–	28	FS_G2	Fail Safe Gate: Gate command for external FET Drain used as FS
–	29	FS_S2	Fail Safe Source: to be connected to external FET Source used as FS. VDS monitor
–	30	FS_D2	Fail Safe Drain: to be connected to external FET Drain used as FS. VDS monitor
–	31	FS_D3	Fail Safe Drain: to be connected to external FET Drain used as FS. VDS monitor
–	32	FS_S3	Fail Safe Source: to be connected to external FET Source used as FS. VDS monitor
–	33	FS_G_3	Fail Safe Gate: Gate command for external FET Drain used as FS



## 3 Product Characteristics

### 3.1 Absolute maximum ratings

This part may be irreparably damaged if taken outside the values specified in the next table. Operation above the absolute maximum ratings may also cause a decrease in reliability. The operating junction temperature range is from -40 °C to +175 °C. The maximum junction temperature must not be exceeded. All voltages are with respect to analog ground pin GNDA.

**Table 2. Absolute maximum ratings**

Pin name	Type	Test condition	Min	Typ	Max	Unit	Pin type
VBATP	Global		-0.3	–	40	V	S
VCP	Local	Note: VCP-VBATP<13V, VBATP-VCP<0.3V	-0.3	–	50	V	S
VC1, VC3	Local	Note: VCx-VBATP<0.3V	-0.3	–	40	V	O
VC2, VC4	Local	Note: VCx-VBATP<13V VBATP-VCx<0.3V	-0.3	–	50	V	O
VS_SOLx	Global		-0.3	–	40 <sup>(1)</sup>	V	S
LOAD_SOLx	Global		-0.3	–	40 <sup>(1)</sup>	V	O
GND_SOLx	Local		-0.3	–	0.3	V	I
VDD	Local		-0.3	–	19	V	S
VDDIO	Local		-0.3	–	19	V	S
GNDD	Local		-0.3	–	0.3	V	S
FS_D0	Global		-0.3	–	40	V	I
FS_G0	Local	Internally shorted to FS_S0 (off phase) Note: FS_G0-FS_S0<13V	-2 <sup>(2)</sup>	–	50	V	O
FS_S0	Global	Note: FS_S0-FS_G0<0.3V	-2	–	50	V	O
CS, SCLK, MOSI, EN_DR, RESn, INx_DISx	Local		-0.3	–	19	V	I
MISO, FAULTn	Local		-0.3	–	19	V	O

1. 35V AMR over life-time, 40V for ISO-pulse transients (as defined in ISO7637-2 standard).

2. biased condition, -0.3V for unbiased conditions/sleep mode.

### 3.2 Latchup trials

Latch-up tests performed according to JEDEC 78 class 2 Level A

### 3.3 ESD performance

**Table 3. ESD Performance**

Symbol	Parameter	Test condition	Min	Typ	Max	Unit	Pin
ESD HBM	HBM Global pins	ESD according to Human Body Model (HBM), Q100-002 for all pins; (100pF/1,5kΩ)	-4	-	4	kV	Global
ESD HBM	HBM all pins	ESD according to Human Body Model (HBM), Q100-002 for all pins; (100pF/1,5kΩ)	-2	-	2	kV	ALL
ESD CDM Corner	CDM corner pins	ESD according to Charged Device Model (CDM), Q100-011 Corner pins	-750	-	750	V	Corner
ESD CDM	CDM all pins	ESD according to Charged Device Model (CDM), Q100-011 All pins	-500	-	500	V	ALL

### 3.4 Temperature range

**Table 4. Device operating temperature**

Symbol	Parameter	Test condition	Min	Typ	Max	Unit	Pin
T <sub>amb</sub>	Operating ambient temperature		-40	-	135	°C	ALL
T <sub>j</sub>	Junction temperature		-40	-	175	°C	ALL
T <sub>stg</sub>	Storage temperature	-	-50	-	175	°C	ALL
T <sub>pas</sub>	Maximum non/operating temperature during passive lifetime	-	-55	-	150 <sup>(1)</sup>	°C	ALL
R <sub>Th j-a</sub>	Thermal Resistance junction to ambient	Package: PWSSO36	-	22	-	°C/W	ALL
R <sub>Th j-c</sub>	Thermal Resistance junction to case	2s2p (4L) board <sup>(2)</sup>	-	1	-		
R <sub>Th j-b</sub>	Thermal Resistance junction to board	Natural convection	-	7	-		
R <sub>Th j-a</sub>	Thermal Resistance junction to ambient	Package: TQFP48 (E-pad: 5x5 mm)	-	27	-	°C/W	ALL
R <sub>Th j-c</sub>	Thermal Resistance junction to case	2s2p (4L) board <sup>(2)</sup>	-	2	-		
R <sub>Th j-b</sub>	Thermal Resistance junction to board	Natural convection	-	9	-		

1. 175°C are allowed for limited time. Eventual Mission profiles with passive lifetime temperature >150°C have to be evaluated by ST to confirm that product qualification is able to cover the required conditions.

2. JESD51-7

All parameters are guaranteed, and tested, in the temperature range from T<sub>j</sub> -40 to 150 °C (unless otherwise specified); the device is still operative and functional at higher temperatures (up to T<sub>j</sub> 175 °C). Device functionality at high temperature up to T<sub>j</sub> = 175 °C is guaranteed by bench validation, electrical parameters are guaranteed by correlation with ATE tests at reduced temperature and adjusted limits (if needed).

## 4 Input / Output

### 4.1 Reset (RESn)

The RESn pin is the reset input for the device. If the RESn pin is low, the device is held in an internal reset state, all outputs channels are disabled, the failsafe pre-drivers are disabled, the FAULTn pin is held low and all registers are reset to their default values. An internal pull down current source will hold the RESn pin low in case the pin is open. RESn pin status is echoed in each SPI frame.

### 4.2 Enable (EN\_DR)

The EN\_DR pin is used to enable / disable the output stages. When EN\_DR pin is low, all channels are disabled, all fail safe pre-drivers are disabled and the FAULTn pin is pulled low if EN\_DR is not masked. The EN\_DR pin can be connected to a general purpose output pin of the microcontroller or to an alternative safety circuit.

When EN\_DR pin is set high, all channels are enabled based on their configuration settings and the fail safe pre-drivers can be controlled through the Fail Safe Configuration Register.

### 4.3 Channel inputs (INx/NDISx)

The INx/NDISx pins serve two purposes depending on the selected load control method. If the load is controlled using the internal closed loop current control circuit (referred to as Hardware Mode), INx/NDISx serves as an enable/disable signal for each channel. When in this mode, if INx/NDISx is high, output control is disabled and when low output control is enabled.

The second operating mode is referred to as Software Mode. When the device is programmed for Software Mode, the INx/NDISx pin serves as the PWM input signal to directly control the output drivers. When INx/NDISx is high, the driving transistor is enabled and the active recirculation transistor is disabled. When INx/NDISx is low, the driving transistor is disabled and the active recirculation transistor is enabled. The driving transistor and active recirculation transistor are dependent on the programmed output configuration, high side or low side. High and low side configurations are explained in [Section 6 Current control drivers](#).

### 4.4 Fault (FAULTn)

The device sets the FAULTn pin low upon detecting internal and external faults and while the device is in reset. The FAULTn pin is open drain and requires an external pull-up resistor connected between VDDIO and the FAULTn pin. A summary of all faults linked to the state of FAULTn are shown in [Table 5](#) and [Table 6](#). Only faults with specified masking register bits can be masked or unmasked by the user. Faults denoted as "None" are automatically linked to FAULTn output status. In addition to the items below, RESn is not masked and is linked to the FAULTn pin by default.

**Table 5. Global and external supply fault pin error masking**

FAULTn Masking function	Register & Data Bit
Digital Ground Loss Fault	SERVFLTMSK1, D[15]
Analog Ground Loss Fault	SERVFLTMSK1, D[14]
Fail Safe VDS Fault	SERVFLTMSK1, D[10]
EEPROM Trimming Data CRC Error Fault	SERVFLTMSK1, D[8]
SPI Timeout Latch Fault	SERVFLTMSK1, D[7]
SPI Timeout Fault	SERVFLTMSK1, D[6]
VDD Under Voltage Fault	SERVFLTMSK1, D[4]
VDD Over Voltage Fault	None
V3V3A Over Voltage	None
V3V3D Under Voltage	None

FAULTn Masking function	Register & Data Bit
V3V3D Over Voltage	None
Oscillator Stuck	None
Oscillator Mismatch	None
Internal Global Register Error	None
CP Under Voltage Fault	SERVFLTMSK1, D[3]
Configuration Register Mismatch Fault	SERVFLTMSK1, D[2]
VBATP Over Voltage Fault	SERVFLTMSK1, D[1]
Core Over Temperature Fault	SERVFLTMSK1, D[0]
SPI Protocol Error Fault	SERVFLTMSK2 D[15]
IN 3 Echo Fault	SERVFLTMSK2 D[4]
IN 2 Echo Fault	SERVFLTMSK2 D[3]
IN 1 Echo Fault	SERVFLTMSK2 D[2]
IN 0 Echo Fault	SERVFLTMSK2 D[1]
EN_DR Echo Fault	SERVFLTMSK2 D[0]

**Table 6. Solenoid channel and fail safe fault pin error masking**

FAULTn Masking function	Register & Data Bit
E_Sol_Thermal Warning	DRVFLTMSK1,D[15]
EEPROM CRC Error on CSA Calibration Data	DRVFLTMSK1,D[14]
EEPROM CRC Error on ADC Trimming Bits	DRVFLTMSK1,D[13]
PWM check fault	DRVFLTMSK1,D[12]
E_Sol_Open Load Fault	DRVFLTMSK1,D[6]
E_Sol_Short Fault	DRVFLTMSK1,D[5]
E_Sol_ADC Fault	DRVFLTMSK1,D[4]
E_LSCLAMP Fault	DRVFLTMSK1,D[3]
E_Sol_HS Over Current Fault	DRVFLTMSK1,D[2]
E_Sol_LS Over Current Fault	DRVFLTMSK1,D[1]
E_Sol Over Temperature Fault	DRVFLTMSK1,D[0]
Out of Regulation Fault	DRVFLTMSK2,D[4]
GND_SOL Loss Fault	DRVFLTMSK2,D[3]
E_RAM_CRC_ERR Fault	DRVFLTMSK2,D[2]
E_SOL_HS/LS Fault	DRVFLTMSK2,D[1]
E_CFG_REG_FAIL Fault	DRVFLTMSK2,D[0]

## 4.5 SPI communications (CS, SCLK, MOSI & MISO)

The CS, SCLK, MOSI & MISO pins provide serial communications between the device and the microcontroller. Please see [Section 9 SPI](#) for details on SPI features, device register functions and electrical characteristics.

## 4.6 Input / output electrical specifications

4.75 V ≤ V<sub>DD</sub> ≤ 5.5 V; 5.5 ≤ V<sub>BATP</sub> ≤ 19 V; -40 °C ≤ T<sub>j</sub> ≤ 175 °C unless otherwise noted. All voltages refer to GNDA pin.

**Table 7. Digital input/output electrical performance**

Symbol	Parameter	Test condition	Min	Typ	Max	Unit	Pin
EN_DR_low	Logic input low detection	–	–	–	0.75	–	EN_DR
EN_DR_high	Logic Input high detection	–	1.75	–	–	V	EN_DR
EN_DR_hyst	Input hysteresis voltage	–	0.1	–	–	V	EN_DR
EN_DR_pd	Inter pull down resistance	V <sub>IN</sub> < 3V	10	38	70	kΩ	EN_DR
EN_DR_deglitch	EN_DR deglitch filter	Guaranteed by scan	9	–	12	μs	EN_DR
EN_DR_test_low	Logic input low detection	–	–	–	6	–	EN_DR
EN_DR_test_high	Logic input high detection	–	9	–	–	V	EN_DR
EN_DR_test_hyst	Input hysteresis voltage	–	0.1	–	–	V	EN_DR
INx_DISx_low	Logic Input low detection	–	–	–	0.75	V	INx_DISx
INx_DISx_high	Logic input high detection	–	1.75	–	–	V	INx_DISx
INx_DISx_hyst	Input hysteresis voltage	–	0.1	–	–	V	INx_DISx
INx_DISx_pd	Inter pull down resistance	V <sub>IN</sub> < 3V	10	38	70	kΩ	INx_DISx
INx_DISx_deglitch_SW	Actuation deglitch in SW mode	Guaranteed by scan	3	3.5	3.9	μs	INx_DISx
INx_DISx_deglitch_HW	Disable deglitch in HW mode	Guaranteed by scan	1.2	1.5	1.7	μs	INx_DISx
RESn_low	Logic input low detection	–	–	–	0.75	–	RESn
RESn_high	Logic input high detection	–	1.75	–	–	V	RESn
RESn_hyst	Input hysteresis voltage	–	0.1	–	–	V	RESn
RESn_pd	Inter pull down resistance	V <sub>IN</sub> < 2.5V	10	38	70	kΩ	RESn
RESn_deglitch	RESn deglitch filter	Guaranteed by scan	4.5	5	7	μs	RESn
FAULTn_ileak	Leakage current in tri-state condition	–	–	–	10	–	FAULTn
FAULTn_low	Logic low level	Ext pull-up 4.7k to VDDIO	–	–	0.4	–	FAULTn
FAULTn_high	Logic high level	Ext pull-up 4.7k to VDDIO	VDDIO-0.4	–	–	V	FAULTn
FAULTn_trise	FAULTn rise time	Ext pull-up 4.7k to VDDIO, Cload=20pF, tested by correlation	–	–	100	ns	FAULTn
FAULTn_tfall	FAULTn fall time	Ext pull-up 4.7k to VDDIO, Cload=20pF	–	–	100	ns	FAULTn

## 5 Power supply

### 5.1 Overview

The L9305 has multiple supply pins. Internal circuits are powered from VDD (+5 V) and VBATP (reverse battery protected) while digital I/O pins are powered from VDDIO (3.3 V or 5 V) for consistency with the main microcontroller I/O operation. The charge pump regulator is sourced from VBATP and supplies the necessary voltage source for the high side integrated valve drivers and fail safe pre-drivers.

### 5.2 Battery supply (VBATP)

This pin is the supply for the charge pump and must be connected to the reverse polarity protected battery voltage supply. VBATP input voltage is diagnosed for over voltage conditions. The status of this diagnostic is readable by SPI. Refer to [Section 8.1.2 VBATP supply over voltage](#) for additional information. The following table summarizes the functional ranges dependent on battery supply voltage.

**Table 8. VBATP electrical performance**

Symbol	Parameter	Test condition	Min	Typ	Max	Unit
VBATP operational	Normal operating voltage range <sup>(1)</sup>	T <sub>amb</sub> = 40 °C, 4.75 V ≤ VDD ≤ 5.5 V	5.5	–	19	V
		T <sub>amb</sub> = 27 °C, 4.75 V ≤ VDD ≤ 5.5 V	5.55	–	19	V
		T <sub>amb</sub> = 125 °C, 4.75 V ≤ VDD ≤ 5.5 V	5.6	–	19	V
VBATP double/load dump	High voltage range <sup>(2)</sup>	T <sub>amb</sub> ≤ 50 °C, 4.75 V ≤ VDD ≤ 5.5 V	19	–	36	V
VBATP over voltage	Over voltage range <sup>(3)</sup>	T <sub>amb</sub> ≤ 50 °C, 4.75 V ≤ VDD ≤ 5.5 V	36	–	40	V
VBATP low voltage	Low Voltage Range Cranking <sup>(4)</sup>	T <sub>amb</sub> = -40 °C, 4.75 V ≤ VDD ≤ 5.5 V	–	–	5.5	V
		T <sub>amb</sub> = 27 °C, 4.75 V ≤ VDD ≤ 5.5 V	–	–	5.55	V
		T <sub>amb</sub> = 125 °C, 4.75 V ≤ VDD ≤ 5.5 V	–	–	5.6	V

1. Device is capable of full functional operation; VBATP must be reversed battery protected
2. Device is capable of full functional operation at Ta ≤ 50 °C with possible degradation of electrical parameters linked to battery line (ex. solenoid slew rate control and current regulation accuracy); There will be no damage to the device, no false operation and input pins will withstand voltage and current defined in Absolute ratings regardless of battery voltage range. Full functional operation will resume without operator intervention when battery voltage returns to Normal Operating Voltage Range at Ta ≤ 50 °C.
3. Ta ≤ 50 °C, duration less than 500 ms. There will be no damage to the device, Solenoid channels and Fail Safe switch will be disabled and input pins will withstand voltages and currents defined in Absolute ratings regardless of battery voltage range. Full functional operation will resume with operator intervention, as described in the specification, when battery voltage returns to normal operating voltage range.
4. Device is capable of full functional operation until charge pump is out of under voltage condition with possible degradation of electrical parameters linked to battery line (ex. solenoid slew rate control and current regulation accuracy). Full functional operation will resume without operator intervention when battery voltage returns to normal operating voltage range.

### 5.3 Load supplies (VSOL1, VSOL2, VSOL3 & VSOL4)

The VSOLx pins are connected to the high side of the solenoid load when the output drivers are configured for low side operation. In low side operation, VSOLx provides power to the load and recirculation path through the high side driver. When the output drivers are configured for high side operation, the VSOLx pin becomes the power source for driving the load thru the high side solenoid driver transistor. In this case, load current is recirculated through the corresponding low side driver. VSOLx pins are independent for each solenoid driver channel. Solenoid driver operation and configuration are detailed in [Section 6.4 Solenoid driver and load diagnostic](#).

## 5.4 Analog and digital supply (VDD)

The VDD pin provides the source voltage for all internal analog (V3V3A) and digital (V3V3D) circuits. An internal start-up circuit connected to VDD initializes the internal regulators (V3V3A & V3V3D) once VDD reaches VDD\_UV threshold. V3V3A & V3V3D regulators are monitored for internal power on reset control (POR). VDD input voltage is diagnosed for over and under voltage conditions. The status of this diagnostic is readable by SPI. Please see [Section 8.1.1 VDD over and under voltage diagnostics](#).

## 5.5 I/O supply (VDDIO)

VDDIO is the supply for all pins that interface with the external microcontroller. This pin must be connected to a supply with the same voltage used by the microcontroller I/O, 3.3 V or 5.0 V. There is no monitoring function associated with VDDIO.

## 5.6 Power-On reset

An internal power on reset circuit holds the device in a reset state if VDD goes below the under voltage threshold. The power on reset is released once VDD is within normal operating range for the specified reset filter time TPOR. The SPI interface can be accessed after the power on reset time.

The fault bit “POR\_flag” in the SERVFLT1 register is set, when the device exits the reset state. This bit is cleared automatically, whenever the SERVFLT1 register is accessed. Also RES\_echo in PINSTATUS register is set, when the device exits the reset state in case of Power-On reset event, despite the state of RESn pin. The microcontroller can use these bits to determine if an internal or external reset has occurred.

A power on reset (POR) can also occur if any of the internal bandgap regulators or internal analog & digital regulators are diagnosed as over or under voltage. Additional details on these and VDD monitoring can be found in sections [Section 8.1.1](#) and [Section 8.1.4](#).

## 5.7 GND (GNDD, GNDA, GND\_SOLx)

The L9305 has two low power ground connections, GNDD and GNDA. These connections are for internal analog and digital control circuits. Exposed pad is connected to substrate and to GNDA. GNDD and GNDA are connected through a pair of anti-parallel ESD diodes. The device has 4 power ground connections, GND\_SOL0, GND\_SOL1, GND\_SOL2 and GND\_SOL3. All ground pins have open circuit detection. Additional details on ground loss detection are shown in [Section 8.1.5 GND loss detection](#).

## 5.8 Charge pump

To effectively bias the high side solenoid drivers and fail safe switch, a charge pump is used to drive the gate voltage above VBATP. The device uses a common charge pump for all channels and is referred to the battery voltage supply connected to the VBATP pin. The charge pump output voltage is present at the VCP pin. The charge pump switching frequency is nominally 470 kHz and its internal control loop reduces emissions by pulse skipping once the targeted operating voltage is reached.

The charge pump circuit requires three external capacitors. A “Tank” capacitor with a recommended value of 220 nF must be connected between the VCP pin and the VBATP pin. Two pump capacitors with recommended values of 68 nF must be connected between the VCP1 and VCP2 pins and also between the VCP3 and VCP4 pins. A built-in monitoring circuit checks if the charge pump output voltage is sufficient to control the high side valve driver. Additional details for charge pump voltage monitoring are shown in [Section 8.1.3 VCP supply under voltage](#).

The charge pump voltage is also used as parallel supply to the VDD supply for internal references to avoid ASIC reset at low VDD input.

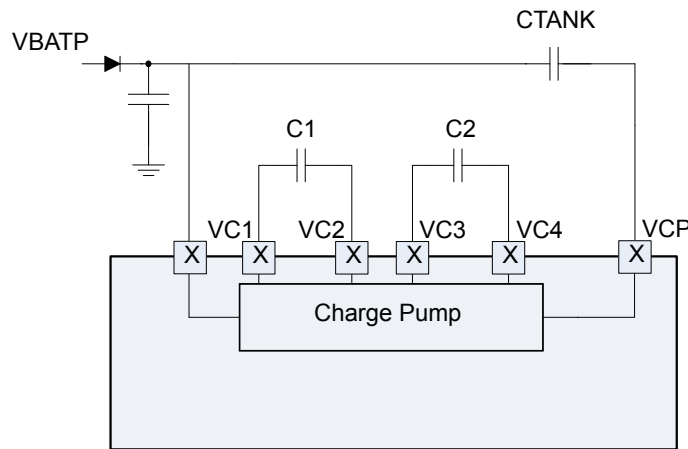
**Figure 6. Charge pump mechanization**

GADG2709181559PS

## 5.9 Startup & power down sequence

L9305 begins initialization and execution of all internal diagnostic and self-test functions upon VDD reaching the VDD\_UV threshold. A detailed list of these monitoring functions is summarized in [Section 8 Safety features](#). While the device is initializing, the FAULTn pin remains low. Upon completing initialization, the SPI POR flag is set high (clear on read) to indicate a POR event has occurred and the FAULTn pin remains low until the RESn input is set high. The RESn input can be set high prior to the device completing initialization but the FAULTn pin will not be released until the POR event is complete. This sequence is shown in [Figure 7](#). Also RES\_echo in PINSTATUS register is set, when the device exits the reset state in case of Power-On reset event, despite the state of RESn pin.

Once the POR event is complete and the RESn input is set high, the device can be configured by the user. All registers maintain RESET default states until both POR is set high and RESn is set by the user.

**Figure 7. Startup procedure example**

Case #1: RESn released before internal operations completed

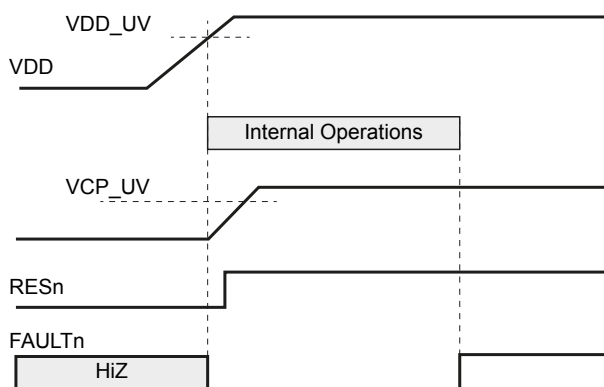

Case #2: RESn released before internal operations completed

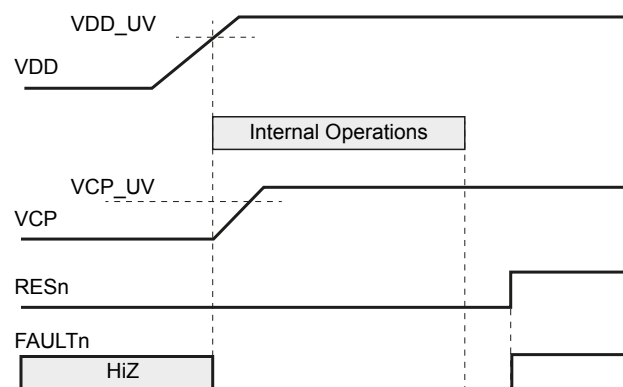

GADG2709181142PS

L9305 power down sequence requires only the VDD supply be disabled. Once the VDD\_UV threshold is reached, the solenoid and fail safe pre-driver outputs are disabled. There are no timing dependencies between VDD and VBATP voltage levels to perform the power down sequence.



## 5.10 Power supply electrical specifications

4.75V ≤ VDD ≤ 5.5V; 5.5 ≤ VBATP ≤ 19V; -40°C ≤ Tj ≤ 175°C unless otherwise noted. All voltages refer to GNDA pin.

**Table 9. Power supply electrical performance**

Symbol	Parameter	Test condition	Min	Typ	Max	Unit	Pin
POR_deglitch	POR analog deglitch		10	18	30	μs	POR
VBATP_stby_cur	VBATP stby current consumption	VDD = 0 V, VBATP = 13 V	–	–	45	μA	VBATP
VDD_stby_cur	VDD stby current consumption	VDD < 0.3 V	–	–	1	μA	VDD
VBATP_on_state_cur	VBATP on state current consumption	VDD = 5 V, VBATP = 13 V, All channels tristated	5	10	20	mA	VBATP
VDD_on_state_cur	VDD on state current consumption	VDD = 5 V	20	30	40	mA	VDD
VDDIO_stby_curr	VDDIO stby current consumption	VDD = 0 V, VDDIO = 5 V	-1	–	1	μA	VDDIO
VDDIO_on_state_curr	VDDIO on state current consumption	VDD = 5 V, VDDIO = 5 V	–	–	5	mA	VDDIO
V3V3A	Internal analog supply line	Design info, not tested	–	3.3	–	V	V3V3A
V3V3D	Internal digital supply line	Design info, not tested	–	3.3	–	V	V3V3D
fosc_main	Main oscillator frequency	–	-5%	16	5%	MHz	fosc
fosc_aux	Auxiliary oscillator frequency	–	-5%	16	5%	MHz	fosc_aux
fosc_mod_freq	Spread spectrum modulation frequency	Design info, not tested	–	125	–	kHz	fosc, fosc_aux
fosc_mod_index_min	Spread spectrum minimum modulation index	Guaranteed by scan	-5	–	-2	%	fosc, fosc_aux
fosc_mod_index_max	Spread spectrum maximum modulation index	Guaranteed by scan	2	–	5	%	fosc, fosc_aux
VCP_start	CP initialization time	VBATP = 13 V, CP from VBATP to VBATP+7 V	–	–	1	ms	CP
tasic_init	Initialization time of ASIC	Time from VDD rising to FAULTn release, RESn HIGH	–	–	5	ms	VDD, FAULTN
CP_freq	Charge pump frequency	–	fosc/34	470	fosc/34	kHz	Cx
VCP_out	CP target output voltage	Design info, not tested	–	VBATP+9	–	V	CP
VCP_out_min	Minimum charge pump output voltage	I <sub>load</sub> = 10 mA, solenoid channels tri-stated, FS disabled, VBATP = 5.5 V	VBATP+7	–	–	V	CP

## 6 Current control drivers

The L9305 provides four independent current control channels. Each channel includes the Driver Control Block, Analog Current Measurement Block and Output Stage. The Output Stage consists of a driving transistor and the recirculation transistor and is user configurable for high side or low side control. When configured as a low side driver, the high side driver recirculates load current. When configured as a high side driver, the low side driver recirculates load current. Configuration examples are shown in [Figure 8](#) and [Section 6 Current control drivers](#).

Both high and low side paths have independent current sense circuits to ensure accurate current control in either configuration. The high or low side configuration is selected in register, Channel<sub>x</sub>\_CONFIGURATION1, D[3]. The device defaults to low side configuration.

**Figure 8. HS driver (left) and LS driver (right) configuration**

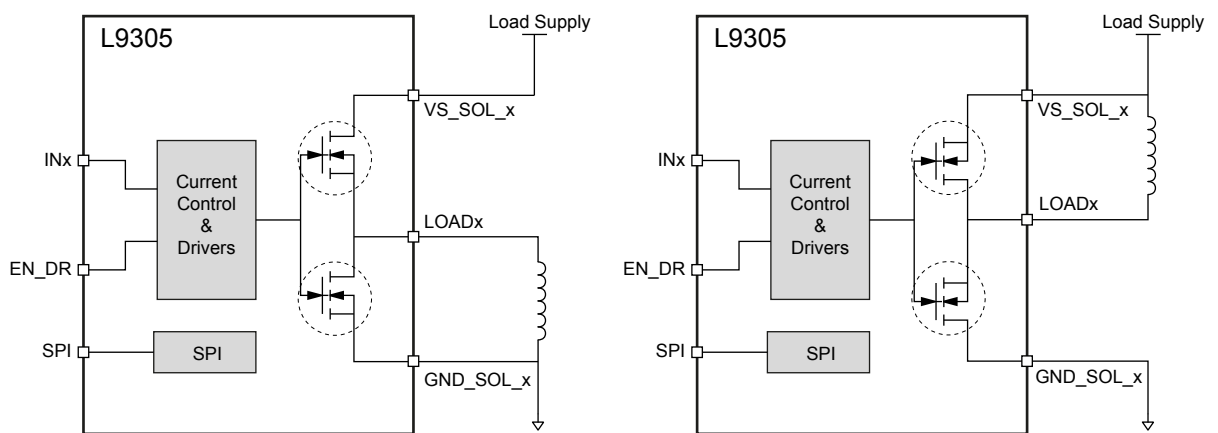

GADG2709181147PS

Calibration and trim data are stored in internal E<sup>2</sup>PROM memory and are used to optimize current control performance. Upon power on reset, the device transfers calibration and trim data into local RAM for use in the Driver Control and Current Measurement blocks. These data are verified using CRC checks, please see [Section 8.4.4](#) for more details.

Load current can be controlled using the internal closed loop control circuits or directly by the microcontroller as summarized below.

- Hardware current control
  - Current Set Point and Switching frequency are programmed through SPI registers
  - Device automatically adjusts the PWM Duty cycle to maintain the programmed load current
- Software current control
  - Current Set Point and Switching frequency are managed directly by the microcontroller
  - L9305 provides average current feedback through SPI and acts only as load driver

Current control configuration and setup are programmed through the SPI interface. Configuration registers (Channel<sub>x</sub>. CONFIGURATION 1 and Channel<sub>x</sub>. CONFIGURATION2) can only be modified when the channel is not enabled (SOLENDR).

### 6.1 Hardware current control

Each channel has four operating states, Disabled, Tristate, PWM and Full on. These operating states are dependent on internal registers settings, SOLENDR register, bit D[7:0] and EN\_DR and INxDISx input pins. A summary of these settings is shown below. Please note the SOLENDR register assigns 2 bits per channel to select driver operating state, therefore the table below shows only two bits.

**Table 10. Solenoid driver status in hardware mode**

EN_DR	INx	Driver Configuration Status		Channel Status
		[1]	[0]	
LOW	X	X	X	Driver Disabled, Off Diagnosis disabled and Masked
HIGH	HIGH	X	X	
HIGH	LOW	0	0	
HIGH	LOW	0	1	Driver in Tristate, Off diagnosis can be switched on
HIGH	LOW	1	0	Driver ON in PWM mode, Off Diagnosis disabled and Masked
HIGH	LOW	1	1	Driver ON in Full ON mode, Off Diagnosis disabled and Masked

**Disabled Mode:** Output drivers are disabled, no bias is present on the driver, off-state diagnostics are masked and cannot be enabled; LS clamp feature is inactive, thus, if an overvoltage occurs when driver is disabled, low side mos will not be protected

**Tristate Mode:** Driver is supplied and kept in a tristate high impedance mode, off state diagnostics can be enabled

**PWM Mode:** Output drivers are actively regulating load current as programmed, off state diagnostics are disabled.

**FULL\_ON Mode:** Output driver is driven to saturation and is kept on continuously until the mode is changed by the user or a fault occurs.

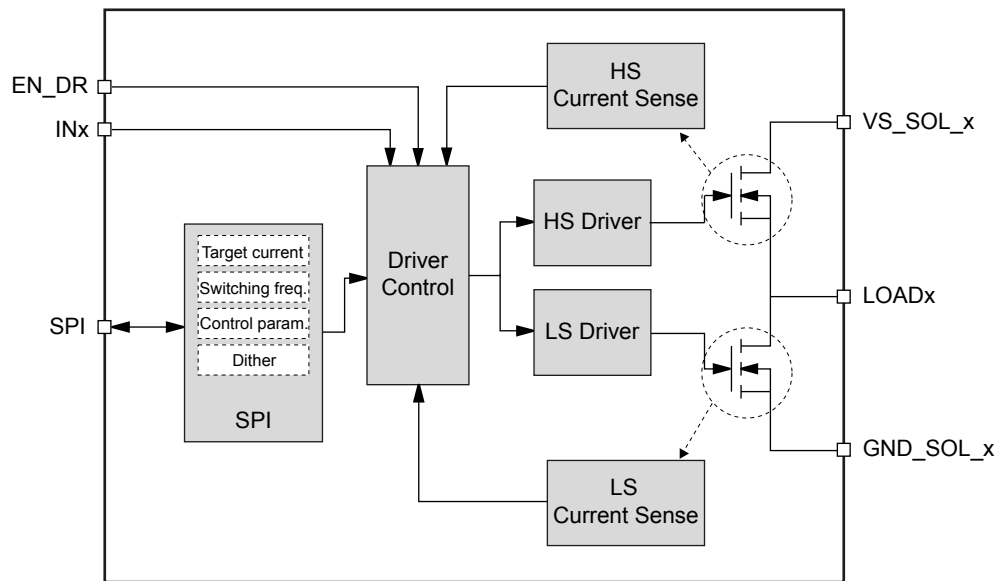
**Figure 9. Hardware control configuration**

GADG2709181150PS

Upon completing channel configuration and set-up as summarized in [Section 6 Current control drivers](#), the internal hardware control loop can then be configured for either fixed frequency or variable frequency current control (HW feedback Frequency Mode D[11] in CTRLCFG register). The current control method (HW mod/SW mode) is selectable using register CONFIGURATION1, D[2]. In addition to selecting the control method, the user must program the targeted load current and operating frequency. Load current is programmed through the Current Set Point Register (SETPOINT) and the operating frequency in the Control Configuration Register (CTRLCFG). Once the channel is enabled, the device begins to PWM control the load current for the targeted current value.

The device can synchronize channel actuation by enabling all channels with a single SPI write operation. Actuation control can also be staggered 90 degrees when programmed for fixed frequency control using the Stagger Enable D[0] bit in SERVENA register.

### 6.1.1 Current set point programming

The targeted average current set point is independently programmable for each channel through the dedicated SPI register (Channel\_x.Current\_Set\_Point) and it is 13-bit wide. The current resolution is programmable in two resolution steps through the HILOAD bit (D[8] in Channel\_x.Configuration1) which will also set the maximum regulated current. Below is a brief summary for using HILOAD to select current range and resolution.

- HILOAD = 0 → Normal current mode - Single bit resolution = 0.25 [mA] - Max Avg. Current 1.5 [A].  
 $TargetAverageCurrent = Setpoint[12:0]*0.25[mA]$
- HILOAD = 1 → High current mode - Single bit resolution = 0.33 [mA] - Max Avg. Current 2.0 [A].  
 $TargetAverageCurrent = Setpoint[12:0]*0.33[mA]$

The maximum guaranteed ripple current for the device's specified accuracy is 0.5 [A] peak to peak for HILOAD=0 and 0.66 [A] peak to peak for HILOAD=1, so that the max load current for correct current control is

- 1500 mA + 250 mA = 1750 mA for HILOAD = 0
- 2000 mA + 330 mA = 2330 mA for HILOAD = 1

If the channel is enabled and programmed with 0x0000h current set point, the power output is forced with duty cycle 0 (recirculation path fully on) and the current measurement is disabled; set point codes higher than 0x1770h are reserved for calibration and offset compensation purposes: in case such codes are selected, the accuracy is not guaranteed.

When CHx.SETPOINT=0000 and channel x is controlled Hardware mode (CONFIGURATION1.D[2]=0), then current measurement is disabled and AVGCUR always returns all '0', even if channel x is driven full-on.

### 6.1.2 PWM switching period programming

The PWM switching period is programmable as shown in the next table, through the dedicated 11-bit field in the SPI register Channel\_x.Control Configuration (CTRLCFG):

**Table 11. PWM period and Frequency Programming**

PWM code [10:0]		Period [μs]	Frequency [Hz]	Status
hex	dec			
0x000	0	50	20000	Short period/High frequency range PWM Period = 50 μs + PWM Code D[10:0] * 5 μs
0x001	1	55	18180	
...	...	...	...	
0x009	9	95	10520	Normal Period/Frequency range. PWM Period = PWM Code D[10:0] * 10 μs
0x00A	10	100	10000	
0x00B	11	110	9090	
...	...	...	...	
0x681	1665	16650	60.06	
0x682	1666	16660	60.02	Values clamped to maximum period of 16.67 ms
0x683	1667	16670	60.02	
...	...	16670	60.02	
0x7FF	2047	16670	60.02	

### 6.1.3 Current control loop configuration

Hardware current control feedback Frequency Mode is user programmable for either variable or fixed frequency operation through register Channelx\_CTRLCFG, bit D[11].

In fixed frequency current control configuration, the programmed PWM period is exactly the actuated period. The control algorithm and a Proportional-Integral (PI) processing circuit with ramp-compare control the duty cycle.

In variable frequency current control configuration, the programmed PWM period is the target set point for the inner frequency control loop. The control algorithm and a zero crossing integrator control both PWM period and duty cycle. The actual PWM period may differ from the target PWM period, especially during transients.

A set of parameters for the loop control is available through SPI registers in order to tune the transient response and settling time of the loop based on the user's load characteristics. These settings and details are discussed in the following sections.

### 6.1.4 Fixed frequency control

The fixed frequency control subtracts the current measurement signal from the programmed set point to create the error signal. The proportional and integral amplifiers process the error signal and generate the PROPORTIONAL and INTEGRAL signals. The processing of PROPORTIONAL and INTEGRAL signals depends on the user programmed values of  $K_p$  and  $K_i$  in the Channel\_x.KGAINS register. The control loop then adds PROPORTIONAL and INTEGRAL signals and compares the result with ramp generator.

**Figure 10. Fixed frequency algorithm**

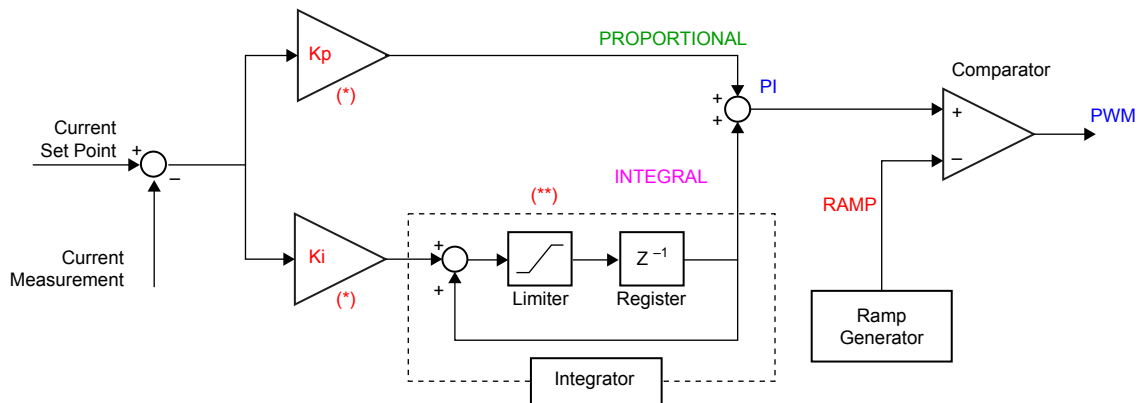

(\*) Programmable parameter.

(\*\*) The integrator limiter is automatically calculated for Fixed Frequency algorithm. It avoids that the PI signal exceeds the max. and min. levels of the RAMP signal. This allows fastest loop transient response.

The LIMITER in the integral path, limits the integral signal automatically to the RAMP signal to ensure the fastest PWM changes to reduce current over and under shoot. An example of current control block diagram is shown in Figure 10.

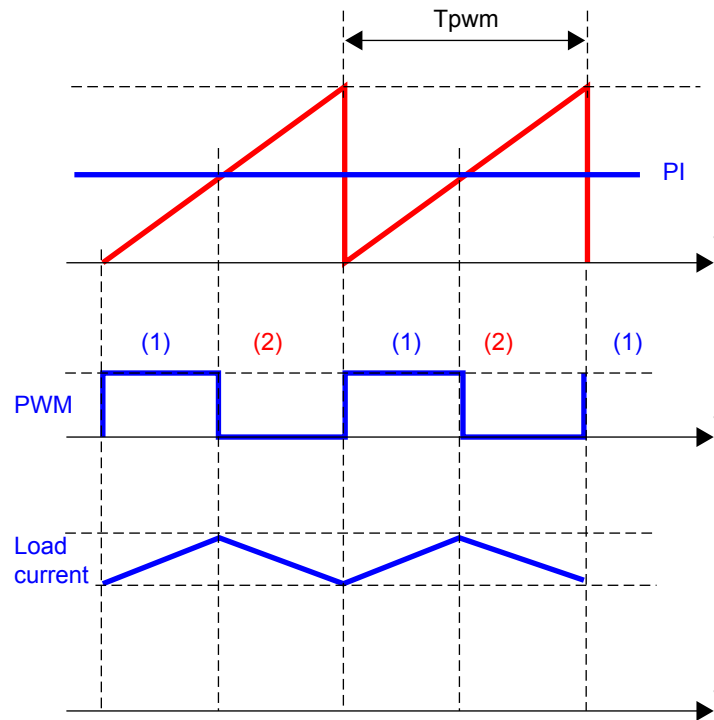
**Figure 11. Fixed frequency signals**

GADG2709181214PS

In fixed frequency current control, basic operation is dependent on the ramp generator and the PI signal as follows:

- Switch OFF point (1): the PI signal crosses the RAMP signal from high to low, the output driver is switched off and the load CURRENT reaches its maximum peak value.
- Switch ON point (2): every clock based TPWM periods, the RAMP signal resets and the output driver is switched on and the load current reaches its minimum peak value.

To optimize current control capability, the user must properly select KP and KI amplitude settings (Channel\_x.KGAINS) for each application.

- **KP**: parameter controls the amplitude of the Proportional signal and is calculated as:  $KP = 2^{KP_{sel}}$
- **KI**: parameter controls the amplitude of the Integral signal and is calculated as:  $KI = 2^{KI_{sel}}$

### 6.1.5 Variable frequency control

From Figure 12, the current control loop subtracts the measured current from the programmed set point to derive an error signal. The integral amplifier with gain KI processes the error signal creating the INTEGRAL signal. The frequency control loop subtracts the PWM period set point  $T_{PWM}$  from the measured PWM period creating a period error signal. The integral amplifier with gain KFI, processes the period error and generates the resulting frequency integral (F\_I) output signal.

Variable frequency control operation is dependent on the INTEGRAL signal, F\_I signal and zero level signal as follows:

- Switch OFF point: the INTEGRAL signal crosses the F\_I signal from high to low, the output driver is switched off and the load CURRENT reaches its maximum peak value.
- Switch ON point: the INTEGRAL signal crosses the zero level signal from low to high, the output driver is switched ON, and the load CURRENT reaches its minimum peak value.

The variable frequency control provides a transient mode for optimization of the transient condition behavior. It eliminates in this way current over/undershoot and allows the fastest reaching of the final frequency. The transient mode is entered in case of a change of current set point (Set Point Change) while the Auto Limit control bit is set. The transient mode is also entered in case the PWM period is longer than a threshold (Long Period Detection). The 2-bit control input Transition Time (D[15:14] in CTRLCFG register) selects the Long Period Detection threshold.

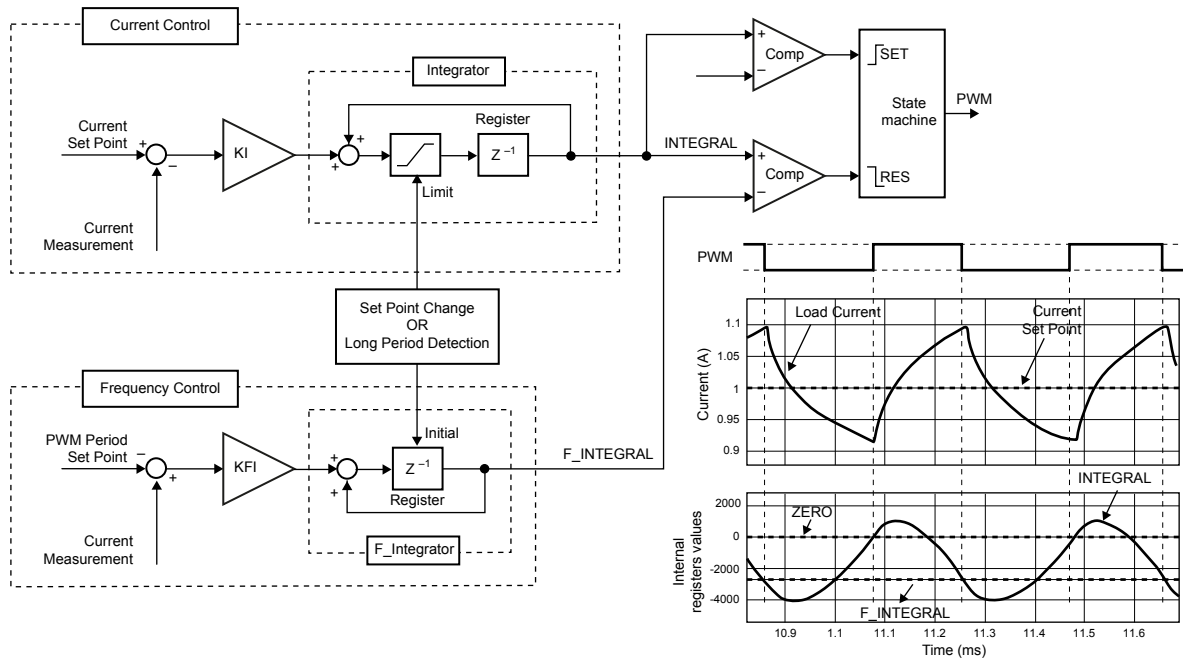
**Figure 12. Variable frequency algorithm**

In transient mode the integrator limits the INTEGRAL signal within user programmable limits, this guarantees the fastest current transitions between different set points without showing over/undershoot. The integrator limits of variable frequency control are not automatically calculated; the user-programmed parameters POSINTLIM and NEGINTLIM are available for optimized positive and negative integrator limits.

In transient mode the F\_INTEGRAL signal at the frequency integrator output is set to a programmable value with the 3 control bits FINIT\_START (D[2:0] in KFREQCTRL register), in this way the F\_INTEGRAL signal starts close to its final value when exiting from transient mode.

To optimize the controller response for different applications, the following parameters must be programmed by the user:

- KI (Channel\_x.KGAINS)
- KFI (Channel\_x.KFREQCTRL)
- POSINTLIM & NEGINTLIM (Channel\_x.INTGLIM)
- Auto Limit (Channel\_x.SETPOINT)
- Transition Time (Channel\_x.CTRLCFG)
- Fint\_Start (Channel\_x.KFREQCTRL)

Programming values can be selected considering the following:

- **KI**: Integral portion of the loop gain. It can be calculated as  $KI = 2^{KI_{sel}}$
- **KFI**: Integral portion of the frequency control loop gain. It can be calculated as  $KFI = 2^{KFI_{sel}}$
- **POSINTLIM**: Positive Integrator Saturation Limit. It can be calculated as  $POSINTLIM = 2^{(POSINTLIM_{sel} - 1)}$
- **NEGINTLIM**: Negative Integrator Saturation Limit. It can be calculated as  $NEGINTLIM = -2^{(NEGINTLIM_{sel} - 1)}$
- **AUTO\_LIMIT**:
  - If AUTOL\_LIMIT\_SEL = 0 → Transient mode is insensitive to changes of Current Set Point
  - If AUTOL\_LIMIT\_SEL = 1 → Any change in the current set point activates the transient mode
- **FINIT\_START**:
  - If FINIT\_START\_SEL = 0 →  $FINIT_{START} = 0$
  - If FINIT\_START\_SEL > 0 →  $FINIT_{START} = NEGINTLIM * 2^{(FINITSTART_{sel} - 7)}$

- **TRANSITION TIME:** Too long PWM period detection: if the current PWM time exceeds this threshold, the controller enters the transient state. It can be programmed as follows:
  - If TRANSITION TIME = 0 →  $TRANSTIME = 2,5 * T_{PWM}$
  - If TRANSITION TIME = 1 →  $TRANSTIME = 4,5 * T_{PWM}$
  - If TRANSITION TIME = 2 →  $TRANSTIME = 8,5 * T_{PWM}$
  - If TRANSITION TIME = 3 →  $TRANSTIME = 16,5 * T_{PWM}$

### 6.1.6 Chopper offset compensation of current sense amplifier

This function cancels the input offset of the current sense amplifier by converting the DC input offset voltage to an AC noise at the chopper frequency. Function is normally enabled and can be disabled by the user via SPI register (OFS\_CMP\_DIS D[14] in Channel\_x.CONFIGURATION1 register).

### 6.1.7 Staggered channel activation

Staggered channel operation is enabled by the user through the SPI Service Enable register, SERVENA (Stagger Enable bit D[0]). When staggered operation is enabled and the targeted regulated current is achieved, the PWM switch-on points is staggered per the following sequence:

- Channel 0 → 0° phase advance; reference channel
- Channel 1 → 90° phase advance
- Channel 2 → 180° phase advance
- Channel 3 → 270° phase advance

This function is specific to fixed frequency current control and is disabled in variable frequency mode.

### 6.1.8 Parallel mode

The 4 channels can be configured to work in parallel mode to allow regulation of higher current set-points: this option is suitable for example in applications where setting HILOAD = 1 is not enough to match targets.

Channel parallelization can be enabled only for fixed channel pairs:

- ch0 can be put in parallel with ch1 only
- ch2 can be put in parallel with ch3 only

In parallel mode one channel acts as a master (ch0, ch2) and the other as a slave (ch1, ch3): both channel current sense measurements are kept active to measure load current split between channel pair: the two measurements are combined and used to close control loop on master logic only.

Configuration of parallel mode is done through master channel registers and in detail the following master parameters are valid for both channels, overwriting slave channel configuration (if any):

- Current set-point,
- Dither parameters,
- Control loop parameters (Ki, Kp, fix/var frequency mode selector, Kfi, etc...)

As a consequence of the described implementation, the resulting resolution of the current and dither set-point registers is doubled since target value is applied on both channels in parallel: it means that in parallel mode 1 LSB = 0.5 mA instead of default 0.25 mA.

Feedback of measured average current is kept distinguished like in normal operation and available for each channel on its own register with nominal LSB of 0.25 mA. The same applies for HS-LS compare check and applied offset compensation.

The following parameters are kept independent between master and slave channels and particular attention must be paid for proper configuration settings:

- HW/SW mode selection
- HS/LS configuration
- INx/NDISx functionality
- diagnostic
- calibration data
- offset compensation



To enable parallel mode the following conditions must be verified, otherwise the channels will be kept independent depending on their own settings:

- Bit 14 and/or Bit15 in SERVENA register must be set to 1 (Bit14 enables parallel mode for ch0-ch1 pair, Bit15 for ch2-ch3 pair)
- SOLENDRV configuration must be equal for selected parallel channel pair

Even if diagnostic is kept independent, faults causing tri-state condition will affect both channels in parallel mode. Parallel mode is mandatory to use only with maximum slew rate setting and in configuration HILOAD=0. Besides, driver active time (T\_ON) must be higher than a minimum value, which directly depends on load current, battery voltage applied to the solenoid and load parameters.

Further guidelines on the usage of this feature are provided in a specific dedicated Application Note.

### 6.1.9 Dither programming

Dither programming (Channel\_x.DITHPGM1 and Channel\_x.DITHPGM2) superimposes a triangular amplitude modulation on the current set point as shown in the Figure 13.

**Figure 13. Dither waveforms definitions**

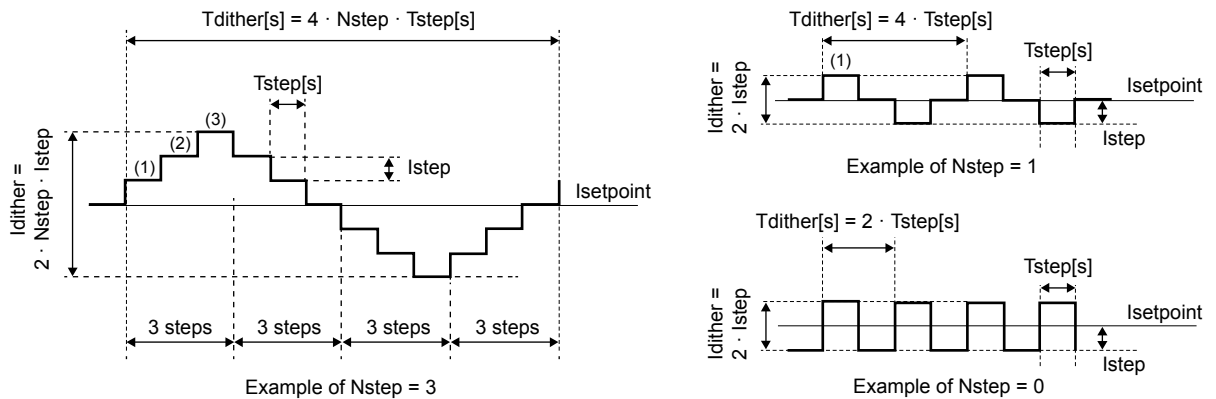

GADG2709181243PS

To implement dither function, the following parameters need to be set according to the user operating requirements.

- **Tstep**: Dither step time duration is programmable as an integer number of PWM periods as defined by the formula  $DitherStepDuration = (Tstep + 1) * T_{pwm}$  where:
  - Tstep is programmable in Channel\_x.DITHPGM2, D[5:0].
  - $T_{PWM}$  is the PWM period programmable in Channel\_x.CTRLCFG register, D[10]
- **Nstep**: number of steps in a quarter of a dither period, where:
  - Nstep is the value programmed in Channel\_DITHPGM2 register, D[12:8]
  - If Nstep = 0, a square wave dither of 2 steps peak to peak will be generated
- **Istep**: Current step amplitude is programmable in Channel\_xDITHPGM1 register, D[7:0] with the same current resolution as the current set point.
  - HILOAD = 0 → Normal current mode - Single bit resolution = 0.25 [mA] - Max Step Current 63.75[mA];  $DitherStepCurrent = Istep[7:0] * 0.25[mA]$
  - HILOAD = 1 → High current mode - Single bit resolution = 0.33 [mA] - Max Step Current 84.15[mA].  $DitherStepCurrent = Istep[7:0] * 0.33[mA]$
- **Tdither**: Dither period calculated as:  $Tdither = 4 * Nstep * Tstep$
- **Idither**: Peak-to-peak current modulation amplitude calculated as:  $Idither = 2 * Nstep * Istep$

Dither can be enabled/disabled via SPI in register Channel\_x.DITHPGM1, D[15]. Dither waveform maximum amplitude is limited by the selected current resolution configuration (HILOAD, register CONFIGURATION1, D[15]) as shown below:

HILOAD = 0 → Normal current mode - Max Dither Current Amplitude = ± 250 [mA];

HILOAD = 1 → High current mode - Max Dither Current Amplitude = ± 330 [mA];

### 6.1.10 Dither synchronization

In variable frequency mode, the PWM switch-on events are not clock based and are dependent on frequency control loop response. Therefore variable frequency mode is naturally asynchronous with respect to the dither steps. However, it is still possible to synchronize dither with the variable frequency PWM control by synchronizing with the actual PWM frequency. There are two options to sync the dither waveform. The two sync types are shown below. Please, note that the function is not valid for fixed frequency operation since all dither steps are synchronous with the PWM control frequency.

- **Dither SYNC Enable** - register Channelx\_DTHPGM1, bit D[14]
  - 0 → Dither synch for variable frequency is disabled
  - 1 → Dither synch for variable frequency is enabled
- **SYNC TYPE** – register ChannelxDTHPGM1, bit D[13]
  - 0 → All Dither Steps are synchronous with the PWM Period. In this case the time base for Dither Step duration is the actual PWM period rather than the exact target set point PWM period
  - 1 → The Dither Period starts synchronous with the actual PWM Period. Only for the initial step in the dither period, the  $T_{step}$  is delayed to the next switch on transition of the PWM period. The time of such initial step may be longer than the programmed period.

## 6.2 Software current control

In this configuration the device works as a driver without internal current control but provides the average measured load current to the MCU through register Channel\_x.AVGCUR, bits D[13:0]. With the average current feedback, the MCU can close the current control loop.

**Figure 14. Software control configuration**

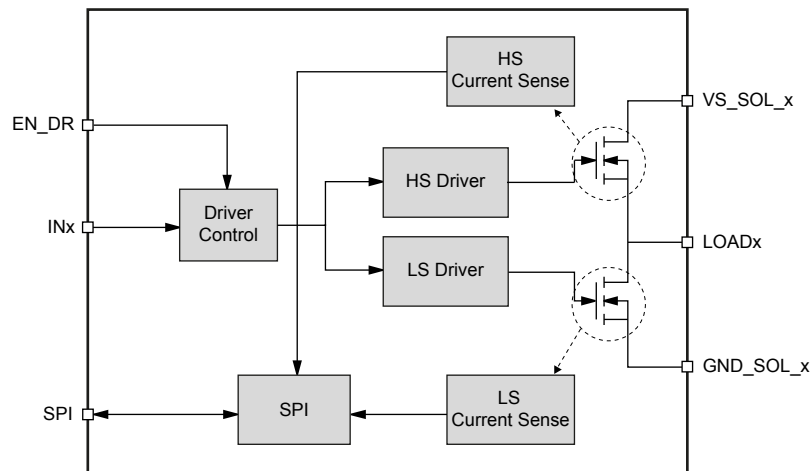

GADG2709181307PS

To avoid spurious switching of the external loads due to noise spikes on INx pins, a digital filter,  $LOADx_{ton\_res}$  and  $LOADx_{toff\_res}$  (where “x” is related to selected channel), has been added to these pins.

Since the filter time is applied on each transition of the INx pin signal, OFF to ON and ON to OFF, the effect limits the minimum period or maximum frequency of the signal delivered to the LOADx pin.

Channel state depends on the EN\_DR input pin and the value of the Driver Configuration/Status SPI register (Global.Solenoid Drivers Enable) as shown below.

**Table 12. Solenoid driver channel status in hardware mode**

EN_DR	Driver configuration status		Channel status
	[1]	[0]	
LOW	X	X	Driver Disabled, Off Diagnosis disabled and Masked
HIGH	0	0	

EN_DR	Driver configuration status		Channel status
	[1]	[0]	
HIGH	0	1	Driver in Tristate, Off diagnosis can be switched on
HIGH	1	0	Driver ON in PWM mode, Off Diagnosis disabled and Masked
HIGH	1	1	Driver ON in Full ON mode, Off Diagnosis disabled and Masked

**Disabled Mode:** Driver is kept disabled. No supply is present onto the driver; off diagnosis is masked and cannot be enabled.

**Tristate Mode:** Driver is supplied and kept in Tristate: Hi impedance. Off state diagnostics (Channel\_x.Configuration) can be enabled.

**PWM Mode:** Driver is supplied and on. Off state diagnostics are masked. Load is driven by the PWM signal applied to the INx pin. Depending on the selected configuration (HS or LS mode), the INx polarity is defined as follows:

**Table 13. INx polarity**

Driver Configuration	Driver Status	INx Pin Status	
		HIGH	LOW
LOW Side (load connected between VS_SOLx pin and LOAD_SOLx pin)	Low side FET	ON	OFF
	High side FET	OFF	ON
HIGH Side (load connected between LOAD_SOLx pin and GND_SOLx pin)	Low side FET	OFF	ON
	High side FET	ON	OFF

**FULL\_ON Mode:** Driver is supplied and in FULL\_ON mode. In this condition, the driver is kept on continuously, until the FULL\_ON mode is removed or a fault occurs.

## 6.3 Solenoid current control feedback

### 6.3.1 Average current

The solenoid current, as a result of internal current sensing, calibration correction and final average calculation over an entire PWM period, is available for SPI reading from Channel\_x.AVGCUR register. Independent of HW or SW mode current control selection, the average current calculation cycle starts at each PWM switch ON event and ends at the next PWM switch ON event. The average current calculated is immediately available to the SPI output register through the dedicated 14-bit field in SPI register Channel\_x.AVGCUR.

- HILOAD = 0 → Normal current mode - Single bit resolution = 0.25 [mA]  
 $AverageCurrent = 2Complement(AvgCur[13:0])*0.25[mA]$
- HILOAD = 1 → High current mode - Single bit resolution = 0.33 [mA]  
 $AverageCurrent = 2Complement(AvgCur[13:0])*0.33[mA]$

In case the Driver input signal is stuck high or low for a time period longer than  $T_{pwm\_max}$ , the TMOUT warning flag is set in Channel\_x.PWMSENSE register and the average current is evaluated only for  $T_{pwm\_max}$ . After timeout, the average current and PWM code calculations restart automatically.

When CHx.SETPOINT=0000 and channel x is controlled Hardware mode (CONFIGURATION1.D[2]=0), then the current measurement is disabled and AVGCUR always returns all '0', even if channel x is driven full-on.

### 6.3.2 Integrator feedback

The current integrator output values are important feedback for proper selection of many control parameters. The device provides integrator feedback through the Channel\_x.INTOUT register. The content of Channel\_x.INTOUT register is determined in the Channel\_x.INTGLIM register bits D[15:14]. The integrator feedback definition is defined below:

#### Integrator low threshold:

The integrator such a threshold corresponds to the integrator value at which the PWM toggles from high to low and the output driver switches off. At this point, the load current reaches its max peak level. In variable frequency this level also corresponds to the “F\_INTEGRAL” signal at the frequency integrator output. Use this integrator reading to correctly set the “Fint\_Start” parameter.

#### Integrator high threshold:

The integrator such a threshold corresponds to the integrator value at which the PWM toggles from low to high and the output driver switches on. At this point, the load current reaches its min peak level. In variable frequency this level is zero. Use this integrator reading to verify the correct functionality of the variable frequency algorithm.

#### Integrator minimum level:

The minimum current integrator level. Use this integrator reading to correctly set the “NEGINTLIM” parameter.

#### Integrator maximum level:

The maximum current integrator level. Use this integrator reading to correctly set the “POSINTLIM” parameter.

### 6.3.3 Solenoid PWM period feedback

The actual PWM time period, whether it is generated by the internal logic in hardware mode or by the INx pins in software mode, is internally measured at each PWM rising edge and provided to the MCU for comparison with the programmed value in register Channel\_x.PWMSENSE. It is also checked against the minimum period reference ( $T_{pwm\_min}$ ) and maximum period reference ( $T_{pwm\_max}$ ) values. Should the PWM period fall outside these limits, the TMOU flag is set in SPI register Channel\_x.PWMSENSE indicating the control loop is working at an unusual value. If no PWM signal is generated after the maximum reference period ( $T_{pwm\_max}$ ), the average current is calculated over  $T_{pwm\_max}$  period of time.

The PWM period is provided using 15 bits with 1 $\mu$ s resolution, providing feedback for periods exceeding  $T_{pwm\_max}$  values. The PWM period feedback value is obtained by the formula:

$$PWMPeriod = Channel\_x.PWMSENSE.PWMCode[\mu s] \quad (1)$$

- $T_{pwm\_min} = 40 \mu s \rightarrow fpwm\_max = 25 \text{ kHz}$
- $T_{pwm\_max} = 16.667 \text{ ms} \rightarrow fpwm\_min = 60 \text{ Hz}$

### 6.3.4 Out of regulation flag

An out of regulation flag is set when the current controller average error is not zero for a time longer than 8 PWM periods, where the PWM period is the programmed PWM period in SPI register Channel\_x.CTRLCFG. The flag is independent for each channel and is only available in Hardware Current Control mode.

## 6.4 Solenoid driver and load diagnostic

### 6.4.1 Thermal protection

Each solenoid channel has a dedicated temperature sensor that continuously monitors the temperature of the Low Side and of the High Side power transistor. Temperature information is available in the dedicated SPI register Channel\_x.TEMPMON. Register data can be decoded from the SPI frame using the following formula:

$$T_J = 1.353 * TemperatureMonitor - 74 [^{\circ}C] \quad (2)$$

Should channel temperature reach the thermal warning threshold T\_WARN, the thermal warning flag is set in the EXCEPTIONS1 register bit D[15]. The warning flag is latched and is cleared upon SPI read if the thermal warning condition is no longer present.

Should channel temperature continue to rise up to the thermal shutdown threshold T\_SD, the related channel is placed in tristate mode (setting the Solenoid Driver Status bits to 01, but keeping the programmed current set-point). This event has a dedicated fault flag in the EXCEPTIONS1 register, bit D[0]. Channel activation is prevented if thermal shut down condition is still present on SPI read. This fault is latched and is cleared upon SPI read if the fault is no longer present. Channel thermal shutdown temperature has no hysteresis, but user can decide which temperature is low enough to re-enable the channel. In fact, by monitoring Channelx.TEMPMON register, user can re-enable the channel when TEMPMON reading is below the temperature desired value: thus a further degree of flexibility is provided.

### 6.4.2 Overcurrent protection

Overcurrent protection is present for each HS and LS solenoid driver. The overcurrent threshold is selectable through SPI register Channel\_x.CONFIGURATION1 bit D[6].

Should an overcurrent fault be detected (on HS or on LS), the related channel is put in tri-state (setting the Solenoid Driver Status bits to 01, but keeping programmed current set-point) and a dedicated diagnostic bit is set in register Channel\_x.EXCEPTION1, bits D[2] for HS and D[1] for LS. To restart the channel, the MCU must clear the fault bit by reading the fault register and re-enable the channel.

### 6.4.3 Supply disconnection

When a solenoid channel is configured for low side operation, current recirculation occurs through the internal high side transistor. If the supply Vs\_solX of the high side driver is lost, the voltage at LOAD\_SOLx pin can become unpredictable and possibly exceed the absolute rating of the device. To prevent this condition from damaging the device, the low side driver has an integrated clamping circuit to limit the peak voltage.

Should the low side clamping structure be activated during normal operation (i.e. solenoid supply line within normal operating range), the channel is put in tri-state (setting the Solenoid Driver Status bits to 01) and the Low Side Clamp Active fault flag D[3] is set in the EXCEPTIONS1 register. To restart the channel, the MCU must clear the fault by reading the EXCEPTIONS1 register and re-enable the channel.

Activation of LS clamp during a load dump event could damage the device due to the high energy of load dump event. To avoid this condition, the LS clamp circuitry is automatically disabled when VBATP pin exceeds deep over-voltage threshold, as defined in [Section 8.1.6](#).

### 6.4.4 Off state solenoid diagnostics

The device provides independent off-state diagnostics for each channel. Simplified diagrams are shown in [Figure 15](#) and [Figure 16](#) below, depending on the chosen configuration.

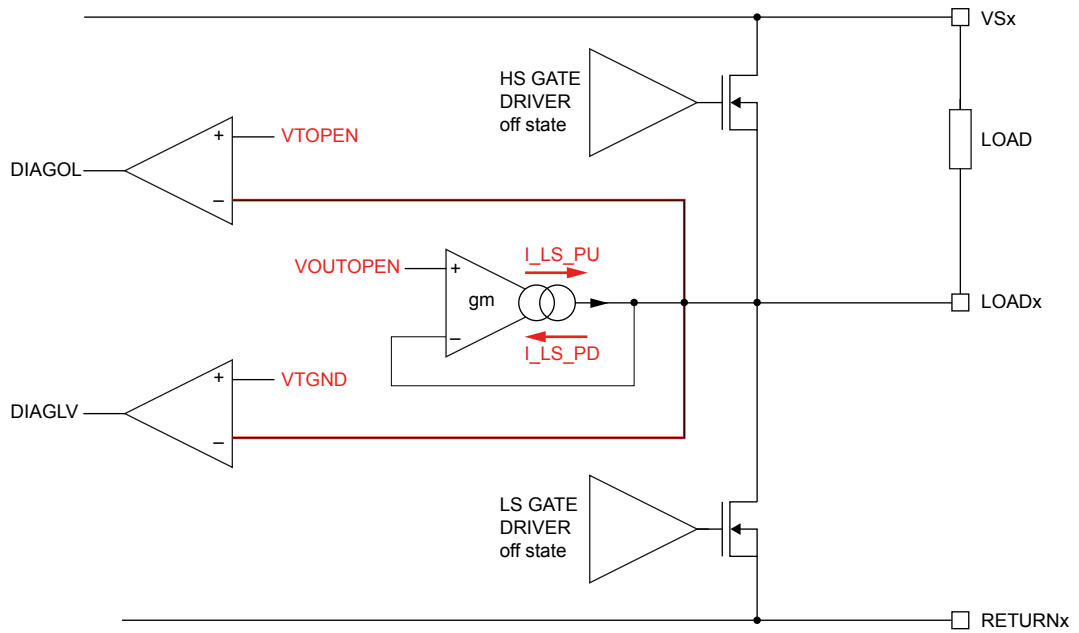
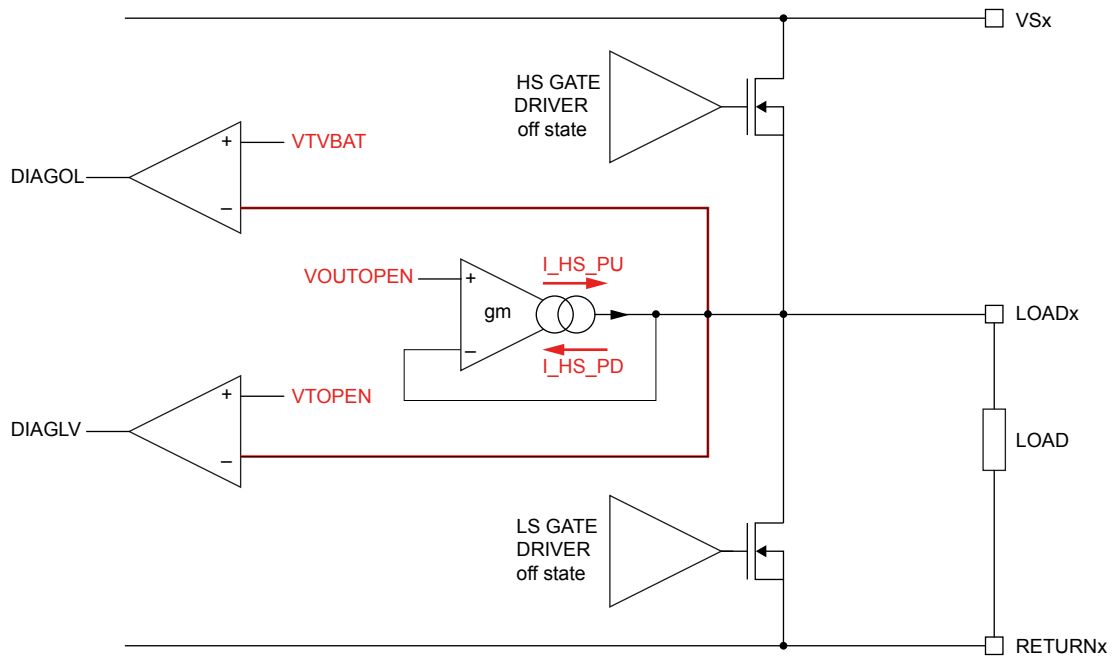
**Figure 15. Low side configuration diagnostic**

**Figure 16. High side configuration diagnostic**

By default, diagnostic pull up/down current sources are disabled and comparator outputs are masked by internal logic. To enable OFF state diagnostics, the channel must be in tri-state (set in the SOLENDRV register Solenoid Driver State\_x[1:0]=01) and enabled using register Channel\_x.CONFIGURATION1, bit [5]. In case the desired channel is put in tri-state after operation a false diagnostic can be sensed due to the time needed to discharge output voltage through the load. To avoid incorrect fault detection, the fault comparators are masked for *td\_blank* filter time. The diagnostic blanking time is programmable through SPI register Channel\_x.CONFIGURATION1, bit D[9]. Blanking time is programmable to best align with external load values and ESD capacitor connected to the output pin. Fault conditions are latched and cleared on SPI read, however they do not prevent from enabling the solenoid channels. OFF state diagnostic comparators are the same for both HS and LS configuration and their output is decoded from internal logic to set the SPI fault bits (Channel\_x.EXCEPTIONS1) according to the following tables

**Table 14. LS diagnostic truth table**

Comparator output		Fault detection	Exception registers	
DIAGOL	DIAGLV		OPEN LOAD	SHORT
0	0	Normal operation – no fault-	0	0
0	1	Not possible	0	0
1	0	Open load	1	0
1	1	Short to ground	0	1

**Table 15. HS diagnostic truth table**

Comparator output		Fault detection	Exception registers	
DIAGOL	DIAGLV		OPEN LOAD	SHORT
0	0	Short to Battery	0	1
0	1	Not possible	0	0
1	0	Open load	1	0
1	1	Normal operation – no fault-	0	0

## 6.5 Valve driver electrical specifications

$4.75\text{ V} \leq \text{VDD} \leq 5.5\text{ V}$ ;  $5.5\text{ V} \leq \text{VBATP} \leq 19\text{ V}$ ;  $\text{VS}_{\text{SOLx}} \leq 19\text{ V}$ ;  $\text{VBATP}-1\text{ V} \leq \text{VS}_{\text{SOLx}} \leq \text{VBATP}+1\text{ V}$ ;  $-40\text{ }^\circ\text{C} \leq \text{T}_j \leq 175\text{ }^\circ\text{C}$  unless otherwise noted. All voltages refer to GNDA pin.

**Table 16. Valve driver power stage electrical parameters**

Symbol	Parameter	Test condition	Min	Typ	Max	Unit	Pin
<b>Solenoid driver power stage</b>							
Irev_VSx	VSx reverse current	Application note: in the application condition, no impact on other functions, no reset generation	-3	–	–	A	VS_SOLx
Irev_LOADx	LOADx reverse current	Application note: in the application condition, no impact on other functions, no leakage from nearby pins, no reset generation	-3	–	–	A	LOAD_SOLx
VSx_lkg	VSx current leakage stby	Output disabled, VDD = 0 V, VS_SOLx = 13 V	-1	–	1	μA	VS_SOLx
LOADx_lkg	LOADx current leakage tristate	Output disabled, VDD = 5 V, VS_SOLx = 13 V, LOAD_SOLx = VS_SOLx or GND	-140	–	100	μA	LOAD_SOLx
HS_RdsON	High side RdsON	T <sub>j</sub> = 150 °C, I <sub>LOAD</sub> = 1 A	–	–	0.33	Ω	LOAD_SOLx
HS_RdsON	High side RdsON	T <sub>j</sub> = 175 °C, I <sub>LOAD</sub> = 1 A	–	–	0.375	Ω	LOAD_SOLx

Symbol	Parameter	Test condition	Min	Typ	Max	Unit	Pin
LS_RdsON	Low side RdsON	$T_j = 150\text{ }^\circ\text{C}$ , $I_{LOAD} = 1\text{ A}$	–	–	0.33	$\Omega$	LOAD_SOLx
LS_RdsON	Low side RdsON	$T_j = 175\text{ }^\circ\text{C}$ , $I_{LOAD} = 1\text{ A}$	–	–	0.375	$\Omega$	LOAD_SOLx
LOAD_SOLx_ton_res	ton filter time	Software mode, Guaranteed by scan	3	3.5	3.9	$\mu\text{s}$	LOAD_SOLx
LOAD_SOLx_toff_res	toff filter time	Software mode, Guaranteed by scan	3	3.5	3.9	$\mu\text{s}$	LOAD_SOLx
LOAD_SOLx_SR00	Voltage slew rate SR00	20% to 80% & 80% to 20%, VBATP = 13 V, $R_{load} = 6\ \Omega$ , $C_{load} = 10\text{ nF}$	0.2	0.3	0.6	V/ $\mu\text{s}$	LOAD_SOLx
LOAD_SOLx_SR01	Voltage slew rate SR01	20% to 80% & 80% to 20%, VBATP = 13 V, $R_{load} = 6\ \Omega$ , $C_{load} = 10\text{ nF}$	0.6	1	1.8	V/ $\mu\text{s}$	LOAD_SOLx
LOAD_SOLx_SR10	Voltage slew rate SR10	20% to 80% & 80% to 20%, VBATP = 13 V, $R_{load} = 6\ \Omega$ , $C_{load} = 10\text{ nF}$	3	4	6	V/ $\mu\text{s}$	LOAD_SOLx
LOAD_SOLx_SR11	Voltage slew rate SR11	20% to 80% & 80% to 20%, VBATP = 13 V, $R_{load} = 6\ \Omega$ , $C_{load} = 10\text{ nF}$	6	8	12	V/ $\mu\text{s}$	LOAD_SOLx
LOAD_SOLx_ton00_HS	ton 00_HS_mode	SW mode from INx_DISx to 20% in HS	8	–	16	$\mu\text{s}$	LOAD_SOLx
LOAD_SOLx_ton00_LS	ton 00_LS_mode	SW mode from INx_DISx to 80% in LS	12	–	20	$\mu\text{s}$	LOAD_SOLx
LOAD_SOLx_ton01_HS	ton 01_HS_mode	SW mode from INx_DISx to 20% in HS	4	–	10	$\mu\text{s}$	LOAD_SOLx
LOAD_SOLx_ton01_LS	ton 01_LS_mode	SW mode from INx_DISx to 80% in LS	5	–	13	$\mu\text{s}$	LOAD_SOLx
LOAD_SOLx_ton10	ton 10	SW mode from INx_DISx to 20% in HS, from INx_DISx to 80% in LS	3	–	8	$\mu\text{s}$	LOAD_SOLx
LOAD_SOLx_ton11	ton 11	SW mode from INx_DISx to 20% in HS, from INx_DISx to 80% in LS	3	–	8	$\mu\text{s}$	LOAD_SOLx
LOAD_SOLx_toff00_HS	toff 00_HS_mode	SW mode, from INx_DISx to 80% in HS	10	–	22	$\mu\text{s}$	LOAD_SOLx
LOAD_SOLx_toff00_LS	toff 00_LS_mode	SW mode, from INx_DISx to 20% in LS	16	–	26	$\mu\text{s}$	LOAD_SOLx
LOAD_SOLx_toff01	toff 01	SW mode, from INx_DISx to 80% in HS, from INx_DISx to 20% in LS	8	–	20	$\mu\text{s}$	LOAD_SOLx
LOAD_SOLx_toff10_HS	toff 10_HS_mode	SW mode, from INx_DISx to 80% in HS	3	–	8	$\mu\text{s}$	LOAD_SOLx
LOAD_SOLx_toff10_LS	toff 10_LS_mode	SW mode, from INx_DISx to 20% in LS	5	–	10	$\mu\text{s}$	LOAD_SOLx
LOAD_SOLx_toff11	toff 11	SW mode, from INx_DISx to 80% in HS, from INx_DISx to 20% in LS	3	–	8	$\mu\text{s}$	LOAD_SOLx

**Table 17. Current control electrical parameters**

Symbol	Parameter	Test condition	Min	Typ	Max	Unit	Pin
<b>Current control</b>							
$I_{reg\_range}$	Current regulation range	HILOAD_x = 0, Design info, not tested	0	–	1.5	A	LOAD_SOLx
$I_{peak\_range}$	Peak Current regulation range	HILOAD_x = 0, Design info, not tested	–	–	1.75	A	LOAD_SOLx
$I_{reg\_res}$	Current regulation resolution	HILOAD_x = 0, Design info, not tested	–	0.25	–	mA	LOAD_SOLx
$I_{reg\_acc\_L}$	Current regulation accuracy	HILOAD_x = 0, $0\text{ A} \leq I_{reg} \leq 0.5\text{ A}^{(1)}$	-5	–	5	mA	LOAD_SOLx
$I_{reg\_acc}$	Current regulation accuracy	HILOAD_x = 0, $0.5\text{ A} < I_{reg} \leq 1.5\text{ A}^{(1)}$	-1	–	1	%	LOAD_SOLx
$I_{reg\_range}$	Current regulation range	HILOAD_x = 1, Design info, not tested	0	–	2	A	LOAD_SOLx
$I_{peak\_range}$	Peak Current regulation range	HILOAD_x = 1, Design info, not tested	0	–	2.33	A	LOAD_SOLx



Symbol	Parameter	Test condition	Min	Typ	Max	Unit	Pin
$I_{reg\_acc\_L}$	Current regulation accuracy	HILOAD_x = 1, $0 A \leq I_{reg} \leq 0.3 A^{(1)}$	-15	–	15	mA	LOAD_SOLx
$I_{reg\_acc\_L}$	Current regulation accuracy	HILOAD_x = 1, $0.3A \leq I_{reg} \leq 0.5A^{(1)}$	-5	–	5	%	LOAD_SOLx
$I_{reg\_acc}$	Current regulation accuracy	HILOAD_x = 1, $0.5 A < I_{reg} \leq 2 A^{(1)}$ . $T_j = -40$ °C	-4	–	4	%	LOAD_SOLx
		HILOAD_x = 1, $0.5 A < I_{reg} \leq 2 A$ . $T_j = 27$ °C	-4	–	4		
		HILOAD_x = 1, $0.5 A < I_{reg} \leq 1.3A^{(1)}$ . $T_j = 150$ °C	-4	–	4		
		HILOAD_x = 1, $1.3 A < I_{reg} \leq 2 A^{(1)}$ . $T_j = 150$ °C	-12	–	12		
<b>Current control – Dither parameters</b>							
Dth_ampl	Dither $T_{step}$ amplitude	Guaranteed by scan	0	–	$255 * I_{reg\_res}$	mA	LOAD_SOLx
Dth_num	Dither $T_{step}$ number	Guaranteed by scan	0	–	31	step	LOAD_SOLx
Tstep	Dither $T_{step}$ duration	Guaranteed by scan	$T_{PWM}$	–	$64 * T_{PWM}$		LOAD_SOLx
Tdither	Dither Period	Guaranteed by scan	$2 * T_{PWM}$	–	$4 * 31 * 64 * T_{PWM}$		LOAD_SOLx
<b>Current control – PWM parameters</b>							
$T_{PWM\_range}$	PWM period range	Guaranteed by scan, nominal system clock frequency	50	–	20470	µs	LOAD_SOLx
$T_{PWM\_res}$	PWM period resolution	$T_{PWM} < 100$ µs, Guaranteed by scan	4.5	5	5.6	µs	LOAD_SOLx
$T_{PWM\_res\_2}$	PWM period resolution	$T_{PWM} < 100$ µs, Guaranteed by scan	9	10	11.1	µs	LOAD_SOLx
$T_{PWM\_min}$	PWM period meter min value	–	36.1	40	44.1	µs	LOAD_SOLx
$T_{PWM\_max}$	PWM period meter max value	–	15.04	16.67	18.38	ms	LOAD_SOLx

1. provided configuration parameters and current control settings are able to allow proper regulation.

**Table 18. Valve driver on state diagnostics parameters**

Symbol	Parameter	Test condition	Min	Typ	Max	Unit	Pin
<b>On state diagnostic</b>							
$I_{HS\_ovc0}$	HS overcurrent	OVC_thres_x=0	–	–	-3	A	LOAD_SOLx
$I_{HS\_ovc1}$	HS overcurrent	OVC_thres_x=1	–	–	-4.5	A	LOAD_SOLx
$I_{LS\_ovc0}$	LS overcurrent	OVC_thres_x=0	3	–	–	A	LOAD_SOLx
$I_{LS\_ovc1}$	LS overcurrent	OVC_thres_x=1	4.3	–	–	A	LOAD_SOLx
$I_{HS\_ocv\_flt}$	HS overcurrent filter time	Guaranteed by scan	3	–	5	µs	LOAD_SOLx
$I_{LS\_ocv\_flt}$	LS overcurrent filter time	Guaranteed by scan	3	–	5	µs	LOAD_SOLx
$T_{SD\_accuracy}$	Temperature ADC accuracy	Design info, not tested	-10	–	10	°C	$T_j\_SOLx$
$T\_WARN$	Temperature warning	–	175	–	185	°C	$T_j\_SOLx$
$T\_SD$	Temperature shut down	–	185	–	200	°C	$T_j\_SOLx$
$T\_SD\_deglitch$	Digital deglitch filter time	Guaranteed by scan	7.5	10	12.5	µs	$T_j\_SOLx$
$T\_WARN\_deglitch$	Digital deglitch filter time	Guaranteed by scan	7.5	10	12.5	µs	$T_j\_SOLx$
$VBATP\_ov\_th1$	VBATP over voltage first threshold	–	27	27.8	29	V	VBATP
$VBATP\_ov\_th1\_deglitch$	VBATP over voltage digital deglitch	Guaranteed by scan	90	–	120	µs	VBATP

Symbol	Parameter	Test condition	Min	Typ	Max	Unit	Pin
Vclamp	LOADx clamp voltage	VBATP < 27V	32	35	38	V	LOAD_SOLx
Vclamp_dly	LOADx disable delay by clamp activation detection	Design info, not tested	–	–	2	µs	LOAD_SOLx
Vclamp_fit	LOADx clamp detection filter time	Guaranteed by scan	3.5	5	7	µs	LOAD_SOLx
Eclamp	Energy clamp single pulse	I <sub>load</sub> = 1 A, T <sub>j</sub> = 100 °C	–	–	25	mJ	LOAD_SOLx
Eclamp	Energy clamp single pulse	I <sub>load</sub> = 1 A, T <sub>j</sub> = 175 °C	–	–	18	mJ	LOAD_SOLx

**Table 19. Valve driver LS off state diagnostics parameters**

Symbol	Parameter	Test condition	Min	Typ	Max	Unit	Pin
<b>Off state diagnostic – LS configuration</b>							
VTGND	Short to GND threshold voltage	LS mode, driver tristate, diagnostic on	1.9	2.1	2.3	V	LOAD_SOLx
VTOPEN	Open load threshold voltage	LS mode, driver tristate, diagnostic on	2.7	2.9	3.1	V	LOAD_SOLx
VOUTOPEN	Open load voltage	LS mode, driver tristate, diagnostic on	2.35	2.5	2.65	V	LOAD_SOLx
I_LS_THOPEN	Open load threshold current	–	40	60	80	µA	LOAD_SOLx
I_LS_PD	Diagnostic pull down current	–	50	70	90	µA	LOAD_SOLx
I_LS_PU	Diagnostic pull up current	–	55	75	95	µA	LOAD_SOLx
td_blank_0	Blank time 0	Bit_blank_x = 0, Guaranteed by scan	5	–	7.5	ms	LOAD_SOLx
td_blank_1	Blank time 1	Bit_blank_x = 1, Guaranteed by scan	2.5	–	3.75	ms	LOAD_SOLx
tflt_diagoff	Filter time	Guaranteed by scan	55	–	80	µs	LOAD_SOLx
	Minimum OFF time for correct diagnostic (Blank time 0)	Application note (esd cap < 12 nF, Bit_blank = 0)	7.58	–		ms	LOAD_SOLx
	Minimum OFF time for correct diagnostic (Blank time 1)	Application note (esd cap < 6 nF, Bit_blank = 1)	3.83	–		ms	LOAD_SOLx

**Table 20. Valve Driver HS Off State Diagnostic Parameters**

Symbol	Parameter	Test condition	Min	Typ	Max	Unit	Pin
<b>Off State Diagnostic – HS Configuration</b>							
VTVBAT	Short to battery threshold voltage	HS mode, driver tristate, diagnostic on	2.7	2.9	3.1	V	LOAD_SOLx
VTOPEN	Open load threshold voltage	HS mode, driver tristate, diagnostic on	1.9	2.1	2.3	V	LOAD_SOLx
VOUTOPEN	Open load voltage	HS mode, driver tristate, diagnostic on	2.35	2.5	2.65	V	LOAD_SOLx
I_HS_THOPEN	Open load threshold current	–	30	60	90	µA	LOAD_SOLx
I_HS_PU	Diagnostic pull up current	–	55	70	95	µA	LOAD_SOLx
I_HS_PD	Diagnostic pull down current	–	60	70	100	µA	LOAD_SOLx
td_blank_0	Blank time 0	Bit_blank_x = 0, Guaranteed by scan	5	–	7.5	ms	LOAD_SOLx
td_blank_1	Blank time 1	Bit_blank_x = 1, Guaranteed by scan	2.5	–	3.75	ms	LOAD_SOLx
tflt_diagoff	Filter time	Guaranteed by scan	55	–	80	µs	LOAD_SOLx
	Minimum OFF time for correct diagnostic (Blank time 0)	Application note (esd cap < 12nF, Bit_blank = 0)	7.58	–		ms	LOAD_SOLx
	Minimum OFF time for correct diagnostic (Blank time 1)	Application note (esd cap < 6nF, Bit_blank = 1)	3.83	–		ms	LOAD_SOLx

## 7 High side fail safe pre-driver

For safety purpose the solenoid loads must be connected to battery line through an external fail safe switch driven by L9305: in case of fault the device must be always able to disconnect external fail safe switch to avoid unwanted energization of solenoid loads. The device provides also diagnostic for external switch, by means of VDS comparator, to detect overcurrent/short conditions and prevent FET from overheating.

In PWSSO36 package, L9305 provides one fail safe pre-driver channel to control an external high side N-channel safety switch. In TQFP48 package, L9305 provides 4 fail safe pre-driver channels to control 4 external high side N-channel safety switches. The pre-driver protects the external N-channel Mosfet by monitoring the drain to source voltage drop across the Mosfet. The threshold for this diagnostic is programmable by the user in the FSCONF register, bits D[1:0]. To enable the output driver, set bit D[2]=1 in the FSCONF register. Upon enabling the output driver, fault monitoring is masked for a period of  $T_{FS\_VDS\_blank}$  and filtered for  $T_{FS\_VDS\_flt}$ . Should a fault be detected, the VDS fault flag is set in the SERVFLT1 register, bit D[10]. The fault bit is latched and is clear on read. To re-enable the failsafe pre-driver, the fault must be cleared and the enable bit must be set again through the SPI (FSCONF register).

An external microcontroller can inhibit pre-driver activation by means of the EN\_DR input pin: if this pin is driven low the failsafe gate is pulled to ground by an internal switch-off path parallel to the digital one. The internal switch off path is triggered also in case of safety relevant internal faults such as stuck of main clock or overvoltage of the logic core supply voltage.

While the device is in either IDLE or RUNNING mode, EN\_DR is set high and FS\_EN is set high through an SPI command, the user can set EN\_DR low and verify that the fail-safe switch is disabled thru the parallel safety switch off path by reading the PINSTATUS register SAFETY echo (bit D[7]). The user can also verify the EN\_DR status reading the PINSTATUS register, bit D[0].

**Figure 17. Fail safe concept**

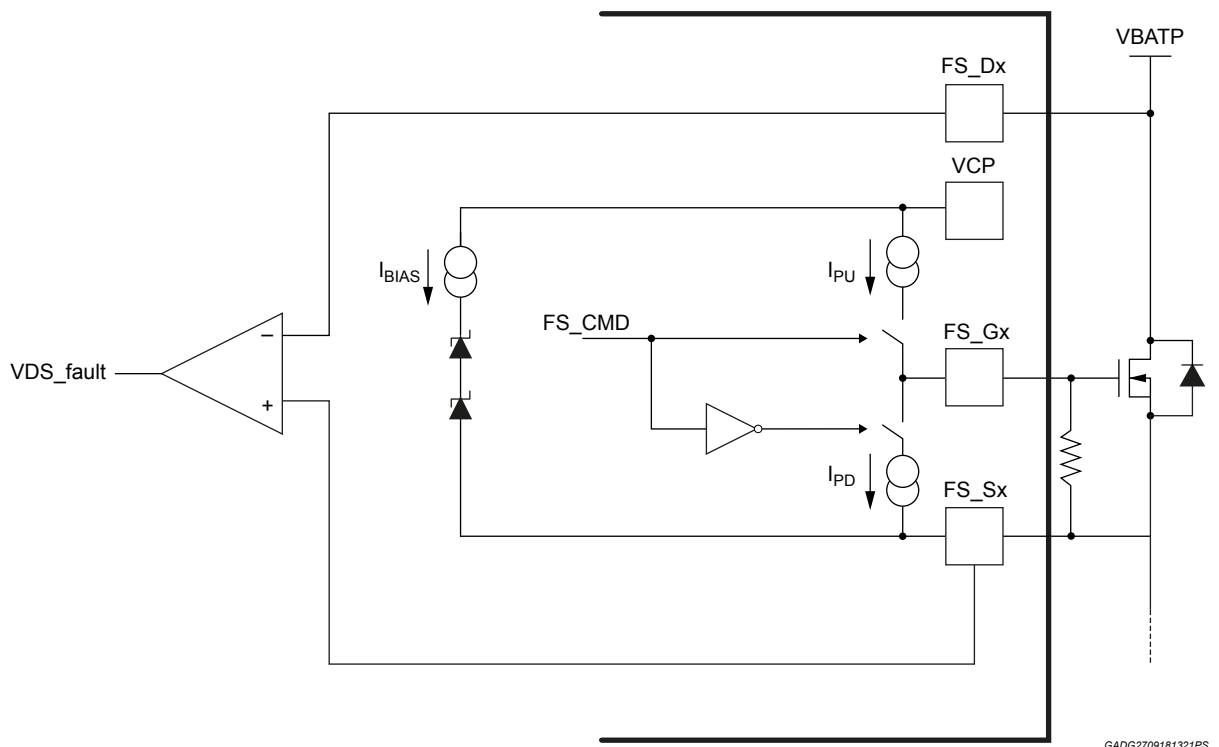

The Fail Safe pre-driver can be in the following states:

- **FS OFF:** Device in Idle State. Fail Safe related registers at their default state. Internal reset state
- **FS IDLE:** Fail safe disabled. Fail safe related registers preserved but Enable Low. Two cases:
  - EN\_DR low. Echo on SPI
  - Error on FS present. Error on SPI and on FAULT pin, if not masked.

- **RUNNING:** Fail Safe enabled and running with gate status depending on SPI command register value

The package option codification is stored inside NVM and verified at power up, in case the package option will not allow for multiple fail safe pre-drivers the unused drivers will be kept disabled.

In case of CRC fault during NVM download the default configuration with only one pre-driver enabled will be applied.

## 7.1 Fail safe predriver diagnostic

The Fail Safe pre-driver has a VDS monitoring that is used to protect the external FET in case of short circuit to ground. Through SPI registers four different VDS thresholds are programmable (FSCONF register, bits D[1:0]). Once FS\_G0 is driven high, after a blanking time ( $T_{FS\_VDS\_blank}$ ) to allow full turn-on of the external FET, the device starts monitoring the falling differential voltage between FS\_D0 and FS\_S0: if the differential voltage does not drop below the VDS voltage threshold within the over-current filter time ( $T_{FS\_VDS\_flt}$ ), the device disables the Fail Safe pre-driver and sets the VDS fault flag in the SERVFLT1 register, bit D[10].

The fault SPI bit is latched until read; once the fault condition disappears to re-enable the Fail Safe pre-driver, the fault has to be cleared and the enable bit must be set again via SPI. The Fail Safe operation is inhibited until the fault register is cleared.

## 7.2 Fail safe predriver electrical characteristics

$4.75 \leq VDD \leq 5.5$ ;  $5.5 \text{ V} \leq VBATP \leq 19 \text{ V}$ ;  $VBATP - 1 \text{ V} \leq FS\_Dx \leq VBATP + 1 \text{ V}$ ;  $-40 \text{ }^\circ\text{C} \leq T_j \leq 175 \text{ }^\circ\text{C}$  unless otherwise noticed. All voltages refer to AGND pin.

**Table 21. Fail safe predriver electrical parameters**

Symbol	Parameter	Test condition	Min	Typ	Max	Unit	Pin
FS_ON	External FET gate driving for ON state	FS_G – FS_S	7	–	10	V	FS_Gx, FS_Sx
FS_OFF	External FET gate driving for OFF state	FS_G – FS_S		–	1	V	FS_Gx, FS_Sx
FS_Isource	FS current source capability	FS_G = 0 V	0.5	1	1.5	mA	FS_Gx
FS_Isink	FS current sink capability	FS_G = VBATP	3	5	7	mA	FS_Gx
FS_S_Ibias_IDLE	FS_S bias current from CP supply in IDLE state	Fail safe Pre-driver enabled, CMD off, FS_Dx = VBATP = 13V, VDD = 5V	-450	-400	-200	$\mu\text{A}$	FS_Sx
FS_S_Ibias_RUNNING	FS_S bias current from CP supply in RUNNING state	Fail safe Pre-driver enabled, CMD on, VDD = 5 V, FS_Dx = VBATP = 13 V	-300	-200	-100	$\mu\text{A}$	FS_Sx
FS_D_Ileak_dis	FS_D leakage current with device in IDLE state	Fail safe Pre-driver disabled, FS_Dx = VBATP = 13 V, FS_Sx = open, VDD = 0 V	-1	–	1	$\mu\text{A}$	FS_Dx
FS_Dx_Rpd	FS_Dx resistor toward FS_Sx pin for VDS threshold generation	Fail safe Pre-driver disabled, FS_Dx = VBATP = 13 V, FS_Sx = 0 V, VDD = 0V	50	140	250	k $\Omega$	FS_Dx, FSx
FS_D_Ileak_idle	FS_D leakage current in IDLE mode	Fail safe Pre-driver disabled, CMD on, FS_Dx = VBATP = 13 V, VDD = 5 V	250	370	500	$\mu\text{A}$	FS_Dx
FS_D_Ileak_en_on	FS_D leakage current in ON state	Fail safe Pre-driver enabled, CMD on, FS_Dx = VBATP = 13 V, VDD = 5 V	140	250	340	$\mu\text{A}$	FS_Dx
FS_D_Ileak_en_on	FS_D leakage current in ON state	Fail safe Pre-driver enabled, CMD off, FS_D = VBATP = 13 V, VDD = 5 V	250	360	550	$\mu\text{A}$	FS_Dx
FS_VDS_00	VDS_threshold_0	FS_PREDRIVER_TH = 00	0.15	0.25	0.35	V	FS_Dx, FS_Sx
FS_VDS_01	VDS_threshold_1	FS_PREDRIVER_TH = 01	0.4	0.5	0.6	V	FS_Dx, FS_Sx
FS_VDS_10	VDS_threshold_2	FS_PREDRIVER_TH = 10	0.65	0.75	0.85	V	FS_Dx, FS_Sx

Symbol	Parameter	Test condition	Min	Typ	Max	Unit	Pin
FS_VDS_11	VDS_threshold_3	FS_PREDRIVER_TH = 11	0.9	1	1.1	V	FS_Dx, FS_Sx
T_FS_VDS_blank	VDS blank time	Guaranteed by scan	90	110	120	µs	FS_Dx, FS_Sx
T_FS_VDS_fit	VDS filter time	EMI filter, guaranteed by design	100	600	1000	ns	FS_Dx, FS_Sx

## 8 Safety features

The L9305 has several integrated features to enable a reliable functional safety system implementation. A complete list of all monitoring and self-test functions is shown in the next table. The following sections detail these features.

**Table 22. Safety monitors and self test summary**

	Function	Primary monitor	Self test
<b>Supply monitors</b>	Vbat	OV	POR
	VCP	UV	POR
	VDD	OV & UV	POR
	GNDA	LOSS	POR
	GNDD	LOSS	POR
<b>Global functions internal monitors</b>	V3V3AN	OV & UV	POR
	V3V3Dig	OV & UV	POR
	Trimming Data Error	CRC	None
	Global Register Error	Mismatch	None
	SPI	Timeout	None
	SPI	n * Timeout Latch	None
	Core Temperature	Over Temperature	None
	Oscillator	Diag Clk stuck-at	None
	Oscillator	Clock Mismatch + Main Clk stuck-at	None
<b>Solenoid channel internal monitor</b>	GND_SOLx	LOSS	POR & On Demand
	HS (On state)	OC	None
	LS (On State)	OC	None
	LS Clamp, On State (Only in LS conf)	OV (dis. for VB > 27V)	None
	STG, Off State (Only in LS conf)		On Demand Only
	Open Load, Off State		On Demand Only
	STB, Off State (Only in HS conf)		On Demand Only
	ADC Mismatch	ADC Compare	Channel on Only
	EPROM Calibration Data Error	CRC & Data Compare	None
	Trim Data Error	CRC	None
	RAM Calibration Data Error	CRC	None
	Driver Temperature	Over Temperature	None
	Driver Status	Command vs. Actual	On Demand Only
	Solenoid Register Error	Mismatch	None
	Out of regulation		On Demand Only
	HS/LS compare		Channel on Only
Solenoid Driver Control Loop	Logic Bist	On Demand Only	
<b>Fail safe</b>	VDS protection	OV	None

## 8.1 Power supply monitoring and diagnostics

### 8.1.1 VDD over and under voltage diagnostics

The VDD power supply input pin is continuously monitored for over and under voltage conditions by comparing the input voltage with an independent reference. In addition to the static voltage monitoring function, the L9305 includes a self-test to verify the proper operation of the comparator and fault logic thus preventing latent faults from influencing device operation. The self-test is run automatically after a power on reset event. Upon detecting a fault, the corresponding fault bits are set as summarized below.

**Table 23. VDD Fault Summary**

Register	Location	Bit Name
SERVFLT1	D4	VDD Under Voltage
SERVFLT1	D5	VDD Over Voltage
SERVFLT2	D6	VDD UV Self Test
SERVFLT2	D7	VDD OV Self Test

A VDD under voltage fault will disable all solenoid drivers and the fail-safe pre-driver. The fault is clear on SPI read but solenoid and fail safe operation must be re-enabled through the SPI.

In case of overvoltage on VDD, fault information is available on SPI, but no action is executed on the solenoid drivers and the fail-safe pre-driver. The fault is clear on SPI read.

### 8.1.2 VBATP supply over voltage

The VBATP power supply input pin is continuously monitored for an over voltage condition by comparing the input voltage with an independent reference. In addition to the static voltage monitoring function, the L9305 includes a self-test to verify the proper operation of the comparator and fault logic thus preventing latent faults from influencing device operation. The self-test is run automatically after a power on reset event. Upon detecting a fault, the corresponding fault bits are set as summarized below.

**Table 24. VBATP Fault Summary**

Register	Location	Bit Name
SERVFLT1	D1	VBATP over voltage
SERVFLT2	D4	VBATP over voltage self-test

A VBATP over voltage fault will disable all solenoid drivers and the failsafe pre-driver. The fault is clear on SPI read but solenoid and fail safe operation must be re-enabled through the SPI.

### 8.1.3 VCP supply under voltage

The VCP charge pump power supply is continuously monitored for an under voltage condition by comparing the input voltage with an independent reference. Upon detecting a fault, the corresponding fault bit is set as summarized below.

**Table 25. Charge pump fault summary**

Register	Location	Bit Name
SERVFLT1	D3	CP under voltage

A VCP under voltage fault will disable all solenoid drivers and the failsafe pre-driver. The fault is cleared on SPI read but solenoid and fail safe operation must be re-enabled through the SPI.

### 8.1.4 Bandgap regulators, internal analog and digital supply monitoring

There are two internal bandgap regulators, main and auxiliary and two internal low voltage regulators, V3VA and V3VD. These regulators are monitored for over and under voltage conditions and a fault on any regulator regardless of the type of the result in a Power On Reset (POR). There are no flags dedicated to these fault conditions other than the POR flag. A POR event resets all registers and disables all solenoids and fail safe. The POR flag is available as shown below.

**Table 26. POR fault summary**

Register	Location	Bit Name
SERVFLT1	D9	POR Flag

In addition to the static voltage monitoring function, the L9305 includes a self-test to verify the proper operation of all comparators and fault logic thus preventing latent faults from influencing the device operation. The self-test function verifies the voltage comparison and logic to ensure the entire path is verified. The self-test is run on demand by setting the ODTEST [D0]. The sequence for initiating the self-test and reading the response is shown below:

- In ODTEST register set bit D[0] = 1
- Monitor ODTEST register bit D[0] for test status, 1 = test in process, 0 = test complete.
- If ODTEST register bit D[0] = 1 the test has succeeded; if the test fails device executes a POR and the related bit will be set on SPI register.

### 8.1.5 GND loss detection

GNDA and GNDD are continuously monitored for loss of ground connection. Ground loss comparators and fault logic are monitored for latent faults using a self-test function. The self-test is automatically performed upon a POR event. Should a ground loss or self-test fault be detected, the corresponding fault bits are set and are summarized below.

**Table 27. GNDA and GNDD fault summary**

Register	Location	Bit Name
SERVFLT1	D15	GNDD Loss
SERVFLT1	D14	GNDA Loss
SERVFLT2	D2	GNDA Loss Self Test
SERVFLT2	D3	GNDD Loss Self Test

A GNDA or GNDD Loss fault will disable all solenoid drivers and the fail-safe pre-driver. The fault is cleared on SPI read but solenoid and fail-safe operation must be re-enabled through the SPI.

Each solenoid driver channel has a dedicated ground connection, GND\_SOL0, GND\_SOL1, GND\_SOL2 and GND\_SOL3. Should a fault be detected, the faulted channel will be disabled and fault flag set as shown below:

**Table 28. Solenoid GND fault summary**

Register	Location	Bit Name
EXCEPTIONS2	D3	Ground Loss

Each solenoid ground connection is continuously monitored for loss of connection. Each loss of ground monitoring circuit also contains a self-test function that must be requested by the user. The sequence for initiating the self-test and reading the response is shown below:

- For the desired channel, in CONFIGURATION2 register set bit D[0] = 1
- Monitor EXCEPTIONS2 register, bit D[5] for test status, 1 = test in process, 0 = test complete.
- Read EXCEPTIONS2 register, bit D[3]; 0 = no fault; 1 = fault



As stated previously, a fault will disable the associated channel and it must be re-enabled by the user. Solenoid ground loss faults do not disable fail safe and are cleared on SPI read.

### 8.1.6 Power supply monitoring and diagnostics electrical characteristics

4.75 V ≤ VDD ≤ 5.5 V; 5.5 V ≤ VBATP ≤ 19 V; -40 °C ≤ T<sub>j</sub> ≤ 175 °C unless otherwise noted. All voltages refer to GNDA pin.

**Table 29. Power supply monitoring electrical performance**

Symbol	Parameter	Test condition	Min	Typ	Max	Unit	Pin
VDD_UV	VDD under voltage detection	–	3.6	–	3.9	V	VDD
VDD_UV_hyst	VDD under voltage hysteresis	–	VDD_UV+0.1	–	VDD_UV+0.5	V	VDD
VDD_UV_deglitch	Digital filter time	Guaranteed by scan	9	–	12	µs	VDD
VDD_OV	VDD over voltage detection	–	5.5	–	7	V	VDD
VDD_OV_hyst	VDD over voltage hysteresis	–	VDD_OV-0.1	–	VDD_OV-0.5	V	VDD
VDD_OV_deglitch	Digital filter time	Guaranteed by scan	90	–	120	µs	VDD
VBATP_OV <sup>(1)</sup>	VBATP over voltage detection	–	36	–	–	V	VBATP
VBATP_OV_hyst	VBATP over voltage hysteresis	–	VBATP_OV-1	–	VBATP_OV-3	V	VBATP
VBATP_OV_deglitch	Digital filter time	Guaranteed by scan	90	–	120	µs	VBATP
CP_UV	Charge Pump under voltage detection	–	VBATP+5	–	–	V	CP
CP_UV_deglitch	Charge Pump Under Voltage Filter time	Guaranteed by scan	9	–	12	µs	CP
V3V3A_uv	Internal Analog supply under voltage monitor	Design info, not tested	2.6	–	–	V	V3V3A
V3V3A_uv_hys	Internal Analog supply under voltage hysteresis	–	V3V3A_uv +0.1	–	V3V3A_uv +0.5	V	V3V3A
V3V3A_ov	Internal Analog supply over voltage monitor	Design info, not tested	3.6	–	4.6	V	V3V3A
V3V3A_ov_hys	Internal Analog supply over voltage hysteresis	–	V3V3A_ov -0.1	–	V3V3A_ov -0.5	V	V3V3A
V3V3D_uv	Internal Digital supply under voltage monitor	Design info, not tested	2.6	–	–	V	V3V3D
V3V3D_uv_hys	Internal Digital supply under voltage hysteresis	–	V3V3D_uv +0.1	–	V3V3D_uv +0.5	V	V3V3D
V3V3D_ov	Internal Digital supply over voltage monitor	Design info, not tested	3.6	–	4.6	V	V3V3D
V3V3D_ov_hys	Internal Digital supply over voltage hysteresis	–	V3V3D_ov -0.1	–	V3V3D_ov -0.5	V	V3V3D
GNDA_lost	Analog ground lost detection	Design info, not tested	0.1	–	0.6	V	GNDA
GNDA_lost_deglitch	GNDA deglitch	Guaranteed by scan	14	–	22	µs	GNDA
GNDD_lost	Digital ground lost detection	Design info, not tested	0.1	–	0.6	V	GNDD
GNDD_lost_deglitch	GNDD deglitch	Guaranteed by scan	14	–	22	µs	GNDD
GND_SOLx_lost	Power ground lost detection	Design info, not tested	0.3	–	1	V	GND_SOLx
GND_SOLx_lost_deglitch	Power ground deglitch	Guaranteed by scan	35	–	50	µs	GND_SOLx

1. LS clamp circuitry automatically disabled, see Section 6.4.3

## 8.2 Main & reference oscillators

The L9305 has two internal clock oscillators, main and reference. The main clock oscillator provides the timing and control for all device operating functions. The reference clock oscillator provides the monitoring reference to verify the main oscillator. The monitor is able to check if one of the two oscillators is stuck and if there is a strong frequency mismatch between them. In case the main oscillator isn't toggling or there is a strong frequency mismatch on it, the monitor will generate an asynchronous activation of a safety switch off path to disable the fail-safe pre-driver: this disable condition will last until fault is recovered.

If a stuck fault on diagnostic oscillator is detected, the device keeps working but reports the corresponding fault through SPI Service Fault 2 register.

Basic implementation of clock monitor is shown in the next figure.

Oscillator monitor is able to detect either stuck condition of one of the two clocks or frequency error of one clock respect the other.

**Figure 18. Oscillator monitor**

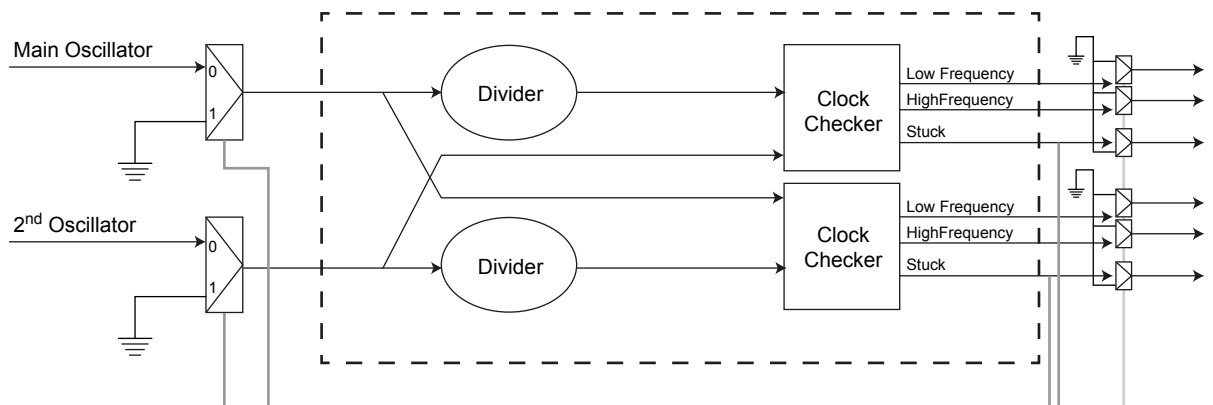

GADG2709181324PS.png

### 8.2.1 Main and reference oscillators electrical characteristics

$4.75\text{ V} \leq \text{VDD} \leq 5.5\text{ V}$ ;  $5.5\text{ V} \leq \text{VBATP} \leq 19\text{ V}$ ;  $-40\text{ }^\circ\text{C} \leq \text{T}_j \leq 175\text{ }^\circ\text{C}$  unless otherwise noted. All voltages refer to GNDA pin.

**Table 30. Main and reference oscillator safety parameters**

Symbol	Parameter	Test condition	Min	Typ	Max	Unit
OSCMON_timeout	Timeout for stuck detection	Guaranteed by scan	–	–	60	$\mu\text{s}$
OSC_freq_error	Max tolerable delta between oscillators	Guaranteed by scan	-15	–	15	%

## 8.3 Safety switch-off path

In case an over voltage condition is detected on either internal analog or digital supply lines a safety switch-off path is triggered in parallel to the main diagnostic functions. The meaning of this safety path is to ensure a safe state for the system even in case the over voltage condition, caused by overshoot, latent fault, etc., will lead to absolute violation for the internal circuitry: in this catastrophic event the functionality of the device cannot be guaranteed so a high voltage protected circuitry is needed to guarantee the switch-off of the external fail safe transistor(s) and disconnect the safety relevant loads from the main supply line. The safety circuitry is placed in an isolated layout area where no top routing is allowed and a safe distance from other circuits is kept to avoid cross-talk.

The safety off-path is triggered by POR event, main oscillator fault and EN\_DR pin low voltage too; safety\_fault trigger signal is the asynchronous combination of the main oscillator fault, EN\_DR monitor and digital supply overvoltage detection, i.e. the faults that cannot be directly managed by the digital core.

An echo of safety off path activation is fed back to the digital core and mapped on the SPI registers: in this way at power up it is always possible to test the safety off path functionality through EN\_DR pin actuation.

### 8.3.1 Safety switch-off path electrical characteristics

4.75 V ≤ VDD ≤ 5.5 V; 5.5 V ≤ VBATP ≤ 19 V; -40 °C ≤ Tj ≤ 175 °C unless otherwise noted. All voltages refer to GNDA pin.

Table 31. Oscillator safety switch-off path parameter

Symbol	Parameter	Test condition	Min	Typ	Max	Unit
tSAFETYn echo_deglitch	Digital deglitch of safetyn echo	Guaranteed by scan	0.2	–	1	µs

## 8.4 Valve drivers

To verify current control integrity, various diagnostic tests are integrated throughout the control path and are explained in the following sections.

### 8.4.1 High side – low side current sense compare

Load current is monitored in both the high side and low side solenoid drivers. The current sensing circuits are independent. The current sense output is multiplexed into an analog to digital converter to close the control loop. To verify the correct current sense functionality, an automatic check between the high and low side current measurements can be made. In the Measured H/L Delta Current register is stored the actual difference between the current sensed from HS and LS circuits, this measured delta current value can be read at power-on by the microcontroller and its value can be written into the Base H/L Delta Current Register, in order to compensate known systematic offsets or delta induced by asymmetrical load transient response and to improve check accuracy. Once the device has the Base H/L Delta Current value recorded, it will continuously monitor the high and low side current values and should the difference exceed the Base H/L Current value, the HS/LS compare fault bit is set (EXCEPTIONS2 register, D[1]). The microcontroller may also perform the same test by simply reading the Measured H/L Delta Current value on a continuous basis and check for deviations.

The current step value is 2 mA per bit. The HS/LS compare fault bit, ie D[1] in the EXCEPTIONS2 register is set high in case the measured current delta exceed the value ± (25 mA + 12.5%\*Isetpoint). An example waveform is shown below in Figure 19.

The current step value is measured and sensed. Delta values are stored in SPI registers with two's complement format:

$$\text{MeasuredDeltaCurrent} = 2\text{Complement}(\text{MeasDeltaCurrent}[7:0]) * 2[\text{mA}] \quad (3)$$

Figure 19. HS/LS current compare example

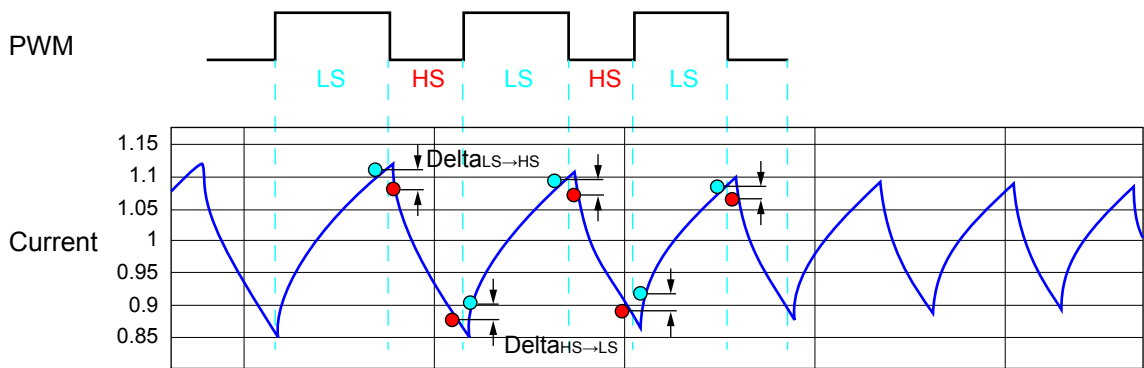

$$\Delta(I) = \text{average}(\Delta_{LS \rightarrow HS}, \Delta_{HS \rightarrow LS})$$

GADG2709181329PS

### 8.4.2 Solenoid current control ADC check

Each solenoid current control channel uses two independent current sense circuits, one for each HS and LS power stage. The current sense outputs are multiplexed into the ADC for digital processing and load current control. Each channel has a dedicated current measurement ADC and a redundant verification ADC. The verification is continuous during run time operation and requires no activation by the user. The comparison is done independently for each channel. Should the comparison check result in a difference of more than ADC\_CHECK, the Solenoid ADC Mismatch Monitor bit, D[4] in the EXCEPTIONS1 register is set high. The fault is cleared upon reading. A simplified block diagram is shown in the figure below.

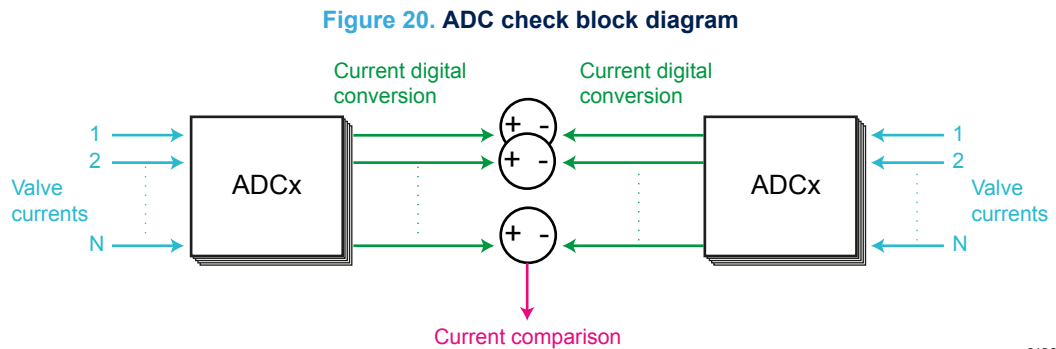

### 8.4.3 Digital control loop logic BIST

Digital control loop logic test verifies the logic controlling solenoid A/D data calibration and the current control loop. The test is performed independently on each channel. This self-test can be activated only if the channel is in tri-state mode as the control loop is disabled during this test. The sequence for initiating the self-test and reading the response is shown below:

- In CONFIGURATION1 register, set Solenoid Logic Bist, bit D[10] =1
- Test status and results are available in the EXCEPTIONS1 register, bits D[10:9]

Test results are cleared on register read. If test is running and channel is activated, result is unpredictable since CONFIGURATION1 register becomes write protected and test cannot be put back in IDLE. In this case it is better to de-activate the test before activating the channel.

### 8.4.4 Calibration data check

Calibration and trimming data are used to compensate solenoid current control and internal reference circuitry. Data is stored in internal 8K bit NVM made of 256-bit sectors with the following architecture:

**Table 32. NVM memory map**

256-bit calibration data field			
120 bits data	8 bits CRC	120 bits data	8 bits CRC

Upon Power on Reset (POR), the L9305 downloads calibration data from non-volatile memory into the appropriate local registers. During this process, the data is verified using the 8-bit CRC field. If a CRC failure is detected in data corresponding to analog trim data, the CRC error on CSA Compensation data bit, D[14] is set in the EXCEPTIONS 1 fault register. If a failure is detected in data corresponding to ADC compensation, the CRC error on A2D trimming data bit, D[13] is set in the EXCEPTIONS 1 fault register. In all cases, the register(s) affected by the faulty data are loaded to "0" to avoid unpredictable operation. Registers loaded with "0" due to a CRC fault will operate uncalibrated thus having reduced performance.

### 8.4.5 Diagnostic comparators

All solenoid diagnostic comparators (overcurrent, off-state diagnostic, ground loss) have analog self-tests implemented to detect latent faults. The self-test must be enabled by the user with the channel in tri-state. The self-test is independent for each channel. Should the test fail, a diagnostic fault flag is set and is cleared upon reading the register. Should actuation be requested while the self-test is in process, the self-test will be terminated with an error (EXCEPTIONS1 register, bits D[10:9]) and actuation will be permitted.

The typical procedure for running the diagnostic comparator self-test is outlined below:

- Disable off-state diagnostics, set CONFIGURATION1 register, D[5] = 0
- Enable diagnostics self-test, CONFIGURATION2 register, D[1] = 1
- Read results in EXCEPTIONS1 register, D[10:9]

#### 8.4.6 PWM check

The L9305 can verify output driver status with respect to the PWM input signal. This function can only be performed when the channel is enabled and controlling load current. Should a mismatch be detected, the PWM Check Fault, D[12] is set in the EXCEPTIONS1 register.

#### 8.4.7 Valve driver safety electrical characteristics

$5.5\text{ V} \leq \text{VBATP} \leq 19\text{ V}$ ;  $5.5\text{ V} \leq \text{VSx} \leq 19\text{ V}$ ;  $-40\text{ }^\circ\text{C} \leq \text{T}_j \leq 175\text{ }^\circ\text{C}$  unless otherwise noticed. All voltages refer to GNDA pin.

**Table 33. Valve driver safety parameters**

Symbol	Parameter	Test condition	Min	Typ	Max	Unit	Pin
Delta_curr_sense	Tolerable mismatch between high side and low side current sense	Guaranteed by scan, $I_{\text{load}} = 0.8\text{ A}$	-15	–	15	%	LOAD_SOLx
ADC_checkHILOAD=0	Tolerable mismatch between functional and safety ADCs	Guaranteed by scan	-32	–	32	mA	
ADC_checkHILOAD=1	Tolerable mismatch between functional and safety ADCs		-42.7	–	42.7	mA	
t_ADC_blank	Self test blanking time	Guaranteed by scan	3	–	4	$\mu\text{s}$	
t_BIST	Solenoid digital BIST duration	Guaranteed by scan	–	–	5	ms	
t_BIST	Analog BIST duration	Guaranteed by scan	0.9	1.7	1.8	ms	
t_EEPROM	EEPROM download time	Guaranteed by scan	–	–	4	ms	
t_PWM_check	PWM check masking time	SR = 00 Guaranteed by scan	$13 \cdot 64 / f_{\text{OSCINT}}$	–	$14 \cdot 64 / f_{\text{OSCINT}}$	–	LOAD_SOLx
t_PWM_check	PWM check masking time	SR = 01 Guaranteed by scan	$9 \cdot 64 / f_{\text{OSCINT}}$	–	$10 \cdot 64 / f_{\text{OSCINT}}$	–	LOAD_SOLx
t_PWM_check	PWM check masking time	SR = 10/11 Guaranteed by scan	$5 \cdot 64 / f_{\text{OSCINT}}$	–	$6 \cdot 64 / f_{\text{OSCINT}}$	–	LOAD_SOLx
PWM_check_deglitch	PWM check fault deglitch time	Guaranteed by scan	0.2	–	1	$\mu\text{s}$	LOAD_SOLx
I_safe_pd	Safety switch off pull down current capability	Design info not tested	1	–	–	mA	FS_Gx
Vgs_off_safed	Residual voltage at FS_G pins with safe off path active	Design info not tested in production	–	–	2	V	FS_Gx

## 8.5 Core over temperature

The device internal temperature is monitored against overheating. If an over temperature event is detected, all solenoid driver outputs are disabled, their enable bit is cleared and their configuration registers are reset, a fault bit cleared on read is set in the SPI registers (Core Over Temperature D[0] bit in SERVFLT1 register). Once the over temperature condition is removed the fault information must be cleared to restart the outputs. Core over temperature is provided with a hysteresis in order to avoid power-on/power-off oscillations when temperature is around over temperature threshold.

### 8.5.1 Core over temperature electrical characteristics

5.5 V ≤ VBATP ≤ 19 V; 5.5 V ≤ VSx ≤ 19 V; -40 °C ≤ T<sub>j</sub> ≤ 175 °C unless otherwise noticed. All voltages refer to GNDA pin.

**Table 34. Core thermal monitoring electrical performance**

Symbol	Parameter	Test condition	Min	Typ	Max	Unit
CORE_ot	CORE over temperature shut down threshold		175	–	185	°C
CORE_ot_hyst	CORE over temperature hysteresis	–	4	7	10	°C
CORE_ot_filt	Digital deglitch	Guaranteed by scan	9	10	12	µs

### 8.6 IC data verification

All read/write registers are mirrored thus resulting in a main register and a mirror register. The contents of each register's main and mirror are verified for consistency. Should a data mismatch between a main read/write register and its mirror register occur, an associated fault bit is set as described below :

- A global register mismatch flag (SERVFLT1, D[2]) is associated to the global registers
  - SERVENA
  - SOLENDR
  - TIMEOUTSPICFG
  - FSCONF
  - SERVFLTMASK1
  - SERVFLTMASK2
- A channel register mismatch flag (EXCEPTIONS2, D[0]) is dedicated to each channel register bank
  - CONFIGURATION1
  - CONFIGURATION2
  - DITHPGM1
  - DITHPGM2
  - SETPOINT
  - CTRLCFG
  - KFREQCTRL
  - KGAINS
  - INTGLIM
  - DRVFLTMASK1
  - DRVFLTMASK2
  - BASEHDELTAACURR

All the flags are cleared-on-read and refer to the entire register bank. No action is taken when a mismatch arises. Data mismatch flags can also be mapped to FAULTn pin using SERVFLTMASK1, D[2] for global register and DRVFLTMASK2, D[0] for channel registers. These flags are masked by default and must be enabled by the users as per their system needs.

## 9 SPI

The SPI interface is used to configure the device, control the outputs and read diagnostic and status registers.

### 9.1 SPI protocol

The SPI protocol is defined by 32-bit frames with 5 bits of CRC (Cyclic Redundancy Check) for transmit and receive. MOSI frame consists of an 8-bit address, 16-bit data, 5-bit CRC field and a one-bit frame counter. MISO frame consists of SPI error and IC status information, address feedback, 16-bit data and 5-bit CRC field. SPI communication uses various safety mechanisms to ensure high safety level coverage as defined in ISO26262 table D.8:

- 5-bit CRC check (Hamming distance of 3 over 26 bits data)
- Frame Counter and Address Feedback
- Timeout Monitoring
- Short and Long Frame Length

All R/W registers are mirrored (i.e., simultaneously written with the same value) and the content of each main register is verified with its related mirror register. Should a mismatch be detected, a fault flag is set. Details of this safety feature are summarized in [Section 8.6](#). The SPI frame format is shown in [Figure 21](#).

**Figure 21. SPI Frame Format**

BIT	31	30	29	28	27	26	25	24	23	22	21	20	19	18	17	16	15	14	13	12	11	10	9	8	7	6	5	4	3	2	1	0
MOSI	RW	Page			Idx				0	cnt	Data[n]																CRC					
MISO	E	IERR	PageFdbk		IdxFdbk				Data[n-1]																CRC							

The protocol implements Out of Frame response meaning the MISO output frame is related to the previous transmitted MOSI frame as shown in [Figure 22](#). The First SPI transfer after power on reset will have a fixed MISO response consisting in the device ID.

**Figure 22. Out of frame response**

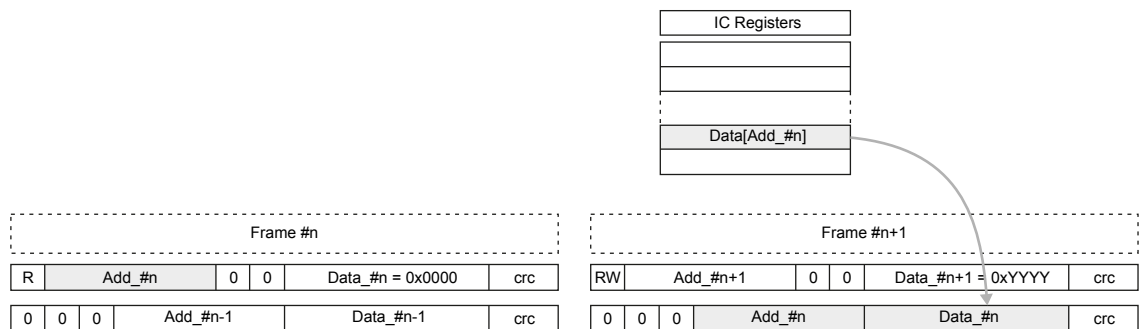

Upon power on reset, the first SPI Frame will set all SPI fault bits and address bits to "0" and the data field will contain the device ID as shown in [Figure 23](#).

Figure 23. SPI frame after Power On Reset

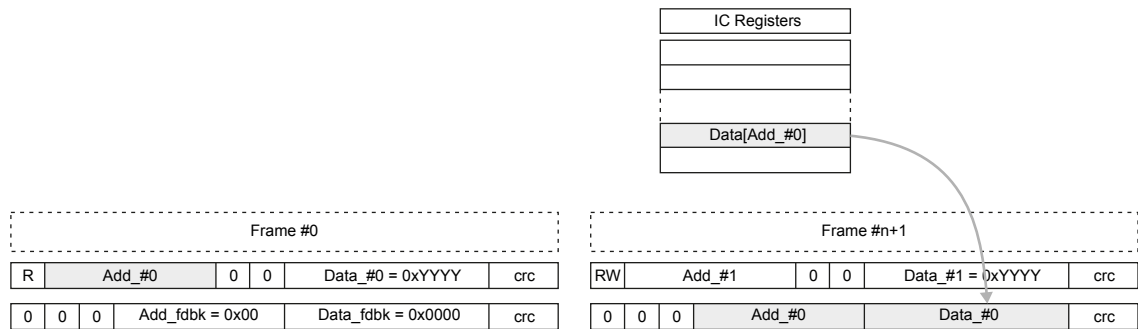

Upon reading a register with Clear on Read fields, the related bits will be cleared only when data has been completely moved on the next SPI access as shown in Figure 24.

Figure 24. Clear on Read SPI sequence

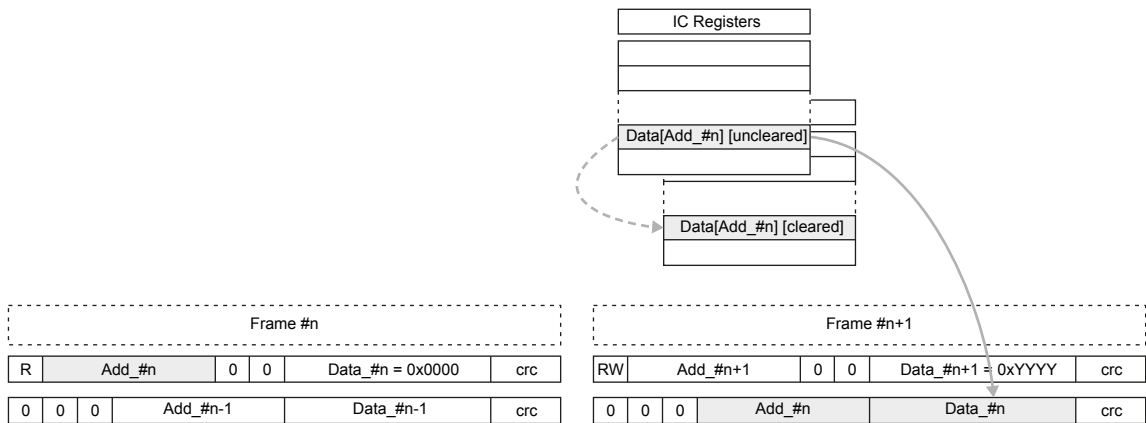

Upon register write, data is updated after the frame is completely received and no error has been detected (CRC, frame sequence, frame length). On the next SPI access, MISO data field will contain updated data content from the written register as shown in Figure 25.

Figure 25. SPI write sequence

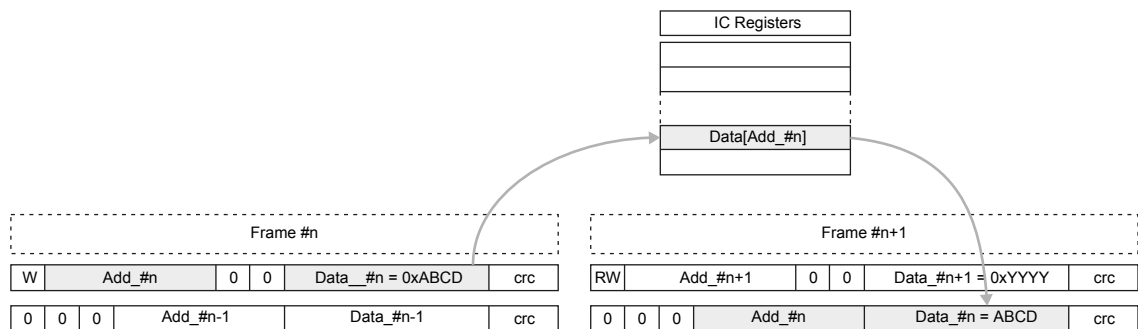

The SPI interface is supplied by VDDIO pin and consists of the following pins and definitions:





**Table 35. SPI time out values**

Dec	Bin	SPI Time Out 63 x 8 x 2N [µs]
0	000	504
1	001	1008
2	010	2016
3	011	4032
4	100	8064
5	101	16128
6	110	32256
7	111	64512

Reset latch function can reset the device to IDLE state if a certain number of timeout events occur. Enable of this function (TIMEOUTSPICFG register, D[1:0] ) and the number of timeout events (TIMEOUTSPICFG register, D[6:5]) is programmed through SPI.

**Table 36. Reset latch enable state**

En_Res_Latch[1] (Reset Latch enable)	Dis_Res_Latch[0] (Reset latch disable)	Reset Latch
0	0	Disabled
0	1	Disabled
1	0	Enabled
1	1	Disabled

**Table 37. Time out reset latch counter values**

Dec	Bin	Time Out Reset Latch Counter [2N+1]
0	00	2
1	01	4
2	10	8
3	11	16

## 9.5 SPI channel exception field

MISO frame has 2 bits (IERR) reserved for solenoid channel exceptions. MISO[29] is the OR of all the exceptions related to Channel 0 and Channel 1, while MISO[30] is the OR of all the exceptions related to Channel 2 and Channel 3.

$$\text{MISO}[29] = (\text{Ch0.Exception1} \& 0xF87F) | (\text{Ch1.Exception1} \& 0xF87F) | \text{Ch0.Exception2} | \text{Ch1.Exception2}$$

$$\text{MISO}[30] = (\text{Ch2.Exception1} \& 0xF87F) | (\text{Ch3.Exception1} \& 0xF87F) | \text{Ch2.Exception2} | \text{Ch3.Exception2}$$

In this way, it is always possible to detect a failure happening on solenoid channel during every SPI communication. Details and clearing of the channel exception can be retrieved by reading the dedicated SPI registers.

## 9.6 SPI electrical specification

4.75 V ≤ VDD ≤ 5.5 V; 5.5 V ≤ VBATP ≤ 19 V; -40 °C ≤ T<sub>j</sub> ≤ 175 °C unless otherwise noted. All voltages refer to GNDA pin.

**Table 38. SPI electrical parameters**

Symbol	Parameter	Test condition	Min	Typ	Max	Unit	Pin
SPI_in_low	Logic input low detection	–	–	–	0.75	V	CS, MOSI, SCLK
SPI_in_high	Logic input high detection	–	1.75	–	–	V	CS, MOSI, SCLK
SPI_in_hyst	Input hysteresis voltage	–	0.1	–	–	V	CS, MOSI, SCLK
SPI_in_pd	Internal pull down resistance	V <sub>IN</sub> < 2.5 V	20	40	80	kΩ	MOSI, SCLK
SPI_in_pu	Internal pull up resistance	V <sub>IN</sub> < 2.5 V	40	90	180	kΩ	CS
MISO_ileak	Leakage current in tri-state condition	–	–	–	10	μA	MISO
MISO_low	Logic low level	I <sub>sink</sub> = 1 mA	–	–	0.4	V	MISO
MISO_high	Logic high level	I <sub>source</sub> = 1 mA	VDDIO-0.4	–	–	V	MISO
MISO_trise	MISO rise time	C <sub>load</sub> = 200 pF	–	–	50	ns	MISO
MISO_tfall	MISO fall time	C <sub>load</sub> = 200 pF	–	–	50	ns	MISO
fclk	Transfer Frequency	Design info 50% duty cycle, not tested <sup>(1)</sup>	–	–	8	MHz	SCLK, MOSI, MISO
tpcld+tsdo_trans	Propagation delay	SCLK to data at SDO is valid C <sub>load_max</sub> = 200 pF including parasitics	–	–	100	ns	SCLK, MISO
tcsdv	NCS=LOW to data at SDO active	C <sub>load_max</sub> = 200 pF including parasitics	–	–	200	ns	CS, MISO
tpchdz	NCS L/H to SDO at high impedance	C <sub>load_max</sub> = 200 pF including parasitics	–	–	200	ns	CS, MISO
tsclch	SCLK before NCS low	Design info, not tested	50	–	–	ns	CS, SCLK
thclcl	SCLK change L/H after NCS=LOW	Design info, not tested	130	–	–	ns	CS, SCLK
tsclcl	SCLK low before NCS high	Design info, not tested	50	–	–	ns	CS, SCLK
thclch	SCLK high after NCS high	Design info, not tested	50	–	–	ns	CS, SCLK
tsclcl	SDI input setup time	Design info, not tested	20	–	–	ns	MOSI
thclcl	SDI input hold time	Design info, not tested	–	–	20	ns	MOSI
tonNCS	NCS min. high time	Design info, not tested	650	–	–	ns	CS
tclh	Minimum Time SCLK=HIGH	Design info, not tested	45	–	–	ns	SCLK
tcll	Minimum Time SCLK=LOW	Design info, not tested	45	–	–	ns	SCLK
Cin	Input pin capacitance	Design info, not tested	–	–	30	pF	MOSI, CS, SCLK
Cout_hiz	MISO output pin capacitance in tri-state	Design info, not tested	–	–	50	pF	MISO

1. SPI max frequency may be less depending on the total capacitive load and MCU timing requirements



## SERVENA

Service enable

15	14	13	12	11	10	9	8	7	6	5	4	3	2	1	0
Parallel mode selection for ch2-ch3	Parallel mode selection for ch0-ch1	Unused				RAM retrigger	Spread Spectrum Disable	Unused						Stagger Enable	
		R						RW	RW	R					

**Address:** Global Base Address + 0x00  
**Type:** RW  
**Reset:** 0x0000  
**Description:** General SERVICE Enable bits

- [15] Parallel mode selection for ch2-ch3
  - [14] Parallel mode selection for ch0-ch1
  - [13:10] Unused
  - [9] RAM retrigger
    - 1: Download calibration data from EEPROM.
    - 0: Download complete or inactive
  - [8] Spread Spectrum Disable:
    - 0: Main Clock Spread Spectrum Enabled
    - 1: Main Clock Spread Spectrum Disabled
  - [7:1] Unused
  - [0] Stagger Enable:
    - 1: Stagger Enabled.
    - 0: Stagger Disabled.
- Valid only when channel is in Fixed Frequency mode

## SOLENDR

Solenoid drivers enable

15	14	13	12	11	10	9	8	7	6	5	4	3	2	1	0
Unused								Solenoid Driver State_3	Solenoid Driver State_2	Solenoid Driver State_1	Solenoid Driver State_0				
R								RW	RW	RW	RW				

**Address:** Global Base Address + 0x01  
**Type:** RW  
**Reset:** 0x0055  
**Description:** Solenoid Driver Configuration

- [15:8] Unused
- [7:6] Solenoid Driver State, Channel 3
  - 00: Driver Off, OFF State Diagnostics disabled and masked
  - 01 : Driver tristate. OFF DIAG depending on bit on config reg
  - 10: Drives on in PWM. OFF DIAG off and masked
  - 11: Drives on in full-on. OFF DIAG off and masked
- [5:4] Solenoid Driver State, Channel 2
  - 00: Driver Off, OFF State Diagnostics disabled and masked
  - 01 : Drives tristate. OFF DIAG depending on bit on config reg
  - 10: Drives on in PWM. OFF DIAG off and masked
  - 11: Drives on in full-on. OFF DIAG off and masked
- [3:2] Solenoid Driver State, Channel 1
  - 00: Driver Off, OFF State Diagnostics disabled and masked
  - 01 : Drives tristate. OFF DIAG depending on bit on config reg
  - 10: Drives on in PWM. OFF DIAG off and masked
  - 11: Drives on in full-on. OFF DIAG off and masked
- [1:0] Solenoid Driver State, Channel 0
  - 00: Driver Off, OFF State Diagnostics disabled and masked
  - 01: Drives tristate. OFF DIAG depending on bit on config reg
  - 10: Drives on in PWM. OFF DIAG off and masked
  - 11: Drives on in full-on. OFF DIAG off and masked

## TIMEOUTSPICFG

### Timeout SPI configuration

15	14	13	12	11	10	9	8	7	6	5	4	3	2	1	0
unused									Timeout NR Reset	Timeout Configuration			Enable Reset Latch	Disable Reset Latch	
R									RW	RW			RW	RW	

**Address:** Global Base Address + 0x02  
**Type:** RW  
**Reset:** 0x0028  
**Description:** SPI TIMEOUT Configuration Register

- [15:7] Unused
- [6:5] Number of SPI timeout events to force an internal reset  
 Timeout NR Reset [1:0]; Calculated as  $2^{(N+1)}$  (e.g., default N= "01", Timeout Events = 4)
- [4:2] Maximum time between valid SPI frames before SPI time-out fault flag is set. Timeout Configuration [2:0]: Calculated as follows:  
 $504 \times 2^N$  [ $\mu$ s] (e.g., default N="010" means 2016 [ $\mu$ s])
- [1] Enable Reset Latch - En\_Res\_Latch[1]:  
 0: Reset Latch Disabled  
 1: Reset Latch Enabled
- [0] Disable Reset Latch - Dis\_Res\_Latch[0]  
 0: Reset Latch Enabled  
 1: Reset Latch Disabled

## FSCONF

## Fail safe pre-driver configuration

15	14	13	12	11	10	9	8	7	6	5	4	3	2	1	0
Unused				FS_3_EN (only TQFP48)	FS3 Predriver Fault Threshold (only TQFP48)		FS_2_EN (only TQFP48)	FS2 Predriver Fault Threshold (only TQFP48)		FS_1_EN (only TQFP48)	FS1 Predriver Fault Threshold (only TQFP48)		FS_EN/FS_0_EN		FS/FS0 Predriver Fault Threshold
R				RW	RW		RW	RW		RW	RW		RW		RW

**Address:** Global Base Address + 0x03  
**Type:** RW  
**Reset:** 0x0000  
**Description:** Fail Safe Configuration and Enable

- [15:12] Unused
- [11] FS3 Predriver Enable – FS\_3\_EN (only TQFP48)
  - 0: Fail Safe Predriver Disabled
  - 1: Fail Safe Predriver Enabled
- [10:9] FS3 Predriver Fault Threshold (only TQFP48)
  - 00: 0.25V VDS Threshold
  - 01: 0.5V VDS Threshold
  - 10: 0.75V VDS Threshold
  - 11: 1.0V VDS Threshold
- [8] FS2 Predriver Enable – FS\_2\_EN (only TQFP48)
  - 0: Fail Safe Predriver Disabled
  - 1: Fail Safe Predriver Enabled
- [7:6] FS2 Predriver Fault Threshold (only TQFP48)
  - 00: 0.25V VDS Threshold
  - 01: 0.5V VDS Threshold
  - 10: 0.75V VDS Threshold
  - 11: 1.0V VDS Threshold



- [5] FS1 Predriver Enable – FS\_1\_EN (only TQFP48)
  - 0: Fail Safe Predriver Disabled
  - 1: Fail Safe Predriver Enabled
- [4:3] FS1 Predriver Fault Threshold (only TQFP48)
  - 00: 0.25V VDS Threshold
  - 01: 0.5V VDS Threshold
  - 10: 0.75V VDS Threshold
  - 11: 1.0V VDS Threshold
- [2] FS/FS0 Predriver Enable – FS\_EN/FS\_0\_EN
  - 0: Fail Safe Predriver Disabled
  - 1: Fail Safe Predriver Enabled
- [1:0] FS/FS0 Predriver Fault Threshold
  - 00: 0.25V VDS Threshold
  - 01: 0.5V VDS Threshold
  - 10: 0.75V VDS Threshold
  - 11: 1.0V VDS Threshold

## CHIPID

Chip ID

15	14	13	12	11	10	9	8	7	6	5	4	3	2	1	0
Unused									Reserved	CHIP ID Version			CHIP ID SubVersion		

**Address:** Global Base Address + 0x1F

**Type:** Read Only

**Description:** Chip Identification Information

Register Bit	Field name/description	Default values	Type
[15:7]	Unused	All "0"	Read
[6]	Reserved	0	Read
[5:3]	CHIP ID Version	001	Read
[2:0]	CHIP ID SubVersion	011	Read

**Note:** *Reserved bit [6] should not be used by customer.*

## 9.9 Fault and test page summary

**Table 41. SPI fault and test page register address mapping**

Idx [hex]	Register
0x00	Pin Status
0x01	On Demand Tests
0x03	Service Fault 1
0x04	Service Fault 2
0x05	Service Fault Mask 1
0x06	Service Fault Mask 2
0x1D	Communication Faults

**PINSTATUS**
**Pin status**

15	14	13	12	11	10	9	8	7	6	5	4	3	2	1	0
Unused							BUSY echo	SAFETYn echo	FAULTn echo	RES echo	IN 3 echo	IN 2 echo	IN 1 echo	IN 0 echo	EN_DR echo

**Address:** Fault Test Base Address + 0x00  
**Type:** R  
**Reset:** 0b0000000X1XXXXXXXXX  
**Description:** Echo Input Status & Internal Settings

- [15:9] Unused
- [8] Busy Echo - Internal signal set high when device is downloading data from EEPROM to various system control registers
- [7] SAFETY echo - internal signal set low when the device has disabled the failsafe pre-driver using the parallel shutdown path
- [6] FAULTn Pin echo - FAULTn pin status feedback
- [5] RES Echo
  - 1: RESn pin is Low
  - 0: RESn pin is high
- [4] IN 3 echo: IN3 Pin Status when in HW mode
  - 0: Solenoid Channel 3 Enabled
  - 1: Solenoid Channel 3 Disabled or SW mode selected
- [3] IN 2 echo: IN2 Pin Status when in HW mode
  - 0: Solenoid Channel 2 Enabled
  - 1: Solenoid Channel 2 Disabled or SW mode selected
- [2] IN 1 echo: IN1 Pin Status when in HW mode
  - 0: Solenoid Channel 1 Enabled
  - 1: Solenoid Channel 1 Disabled or SW mode selected
- [1] IN 0 echo: IN0 Pin Status when in HW mode
  - 0: Solenoid Channel 0 Enabled
  - 1: Solenoid Channel 0 Disabled or SW mode selected
- [0] EN\_DR echo: EN\_DR pin status
  - 0: Driver Disabled
  - 1: Driver Enabled

**ODTESTS**
**On demand self tests**

15	14	13	12	11	10	9	8	7	6	5	4	3	2	1	0
Unused															V3V3 Self Tests
R															RW

**Address:** Fault Test Base Address + 0x01  
**Type:** RW  
**Reset:** 0x0000  
**Description:** Global On Demand Self Tests

[15:1] Unused

[0] V3V3 Self Tests:

1: Start test

0: Test completeShould test fail, POR fault will be latched (SERVFLT1 register).

**SERVFLT1**
**Service Fault 1**

15	14	13	12	11	10	9	8	7	6	5	4	3	2	1	0
Digital Ground Loss	Analog Ground Loss	Unused			Fail Safe VDS Fault	POR flag	EEPROM Trimming Data CRC error	SPI Timeout Latch	SPI Timeout	VDD Over Voltage	VDD Under Voltage	CP Under Voltage	Configuration Register Monitor	VBATP Over Voltage	Core Over temperature
RH	RH	R			RH	RH	R	RH	RH	RH	RH	RH	RH	RH	RH

**Address:** Fault Test Base Address + 0x03

**Type:** R

**Type:** 0x200

**Description:** Service Fault register stores Diagnostic flags of enabled services (i.e., Monitors)

[15] Digital Ground Loss (GNDD Loss)

0: No Fault  
 1: GND\_D Loss  
 Clear on Read

[14] Analog Ground Loss (GNDA Loss)

0: No Fault  
 1: GND\_A Loss  
 Clear on Read

[13:11] Unused

[10] Fail Safe Pre-driver VDS Fault:

0: No Fault  
 1: VDS fault detected  
 Clear on Read

[9] Power On Reset (POR) flag:

0: POR released and flag read  
 1: POR detected  
 Clear on Read

[8] EEPROM Trimming data CRC error:

0: No CRC error  
 1: CRC error

[7] SPI Timeout Latch:

0: No fault  
 1: SPI Communication Timeout Latch Set

- Clear on Read
- [6] SPI Timeout:
  - 0: No fault
  - 1: SPI Communication TimeoutClear on Read
- [5] VDD Over Voltage:
  - 0: No Fault
  - 1: Over Voltage FaultClear on Read
- [4] VDD Under Voltage:
  - 0: No Fault
  - 1: Under Voltage FaultClear on Read
- [3] Charge Pump Under Voltage:
  - 0: No Fault
  - 1: Under Voltage FaultClear on Read
- [2] Configuration Register Monitor Solenoid Drivers Enable, Timeout SPI Config, FS Predriver Config
  - 0: No Fault
  - 1: Register FaultClear on Read
- [1] VBATP Over Voltage:
  - 0: No Fault
  - 1: Over Voltage FaultClear on Read
- [0] Core Over Temperature:
  - 0: No Fault
  - 1: Thermal ShutdownClear on Read

**SERVFLT2**
**Service Fault 2**

15	14	13	12	11	10	9	8	7	6	5	4	3	2	1	0
Clamp inhibit self-test	Clamp inhibit monitor				Unused			VDD OV Self-test	VDD UV Self-test	Unused	VBAT OV Self-test	GNDLOSS D Self-test	GNDLOSS A Self-test	Diag Oscillator Stuck-at Monitor	Main Oscillator Monitor
RH	R				R			RH	RH	R	RH	RH	RH	RH	RH

**Address:** Fault\_Test\_BaseAddress + 0x04

**Type:** R

**Reset:** 0x0000

**Description:** Service Fault register stores Diagnostic flags of enabled services (i.e., Monitors & Self Tests)

- [15] Clamp Diode Inhibit Selftest  
Clear on Read
- [14] Clamp Diode Inhibit Monitor
- [13:8] Unused
- [7] VDD OV Selftest  
0: No Fault  
1: Fault Detected  
Clear on Read
- [6] VDD UV Selftest  
0: No Fault  
1: Fault Detected  
Clear on Read
- [5] Unused
- [4] VBAT OV Selftest  
0: No Fault  
1: Fault Detected  
Clear on Read
- [3] GNDLOSS D Selftest:  
0: No Fault  
1: Fault Detected  
Clear on Read
- [2] GNDLOSS A Selftest:



0: No Fault

1: Fault Detected

Clear on Read

[1] Diag Oscillator Stuck-at Monitor:

0: No Fault

1: Fault Detected

Clear on Read

[0] Main Oscillator Monitor:

0: No Fault

1: Fault Detected

Clear on Read

**SERVFLTMSK1**
**Service Fault Mask 1**

15	14	13	12	11	10	9	8	7	6	5	4	3	2	1	0
Digital Ground Loss	Analog Ground Loss	Unused			Fail Safe VDS Fault	Unused	EEPROM Trimming data CRC error	SPI Timeout Latch	SPI Timeout	Unused	VDD Under Voltage	CP Under Voltage	Configuration Register	VBATP Over Voltage	Core Over Temperature
RW	RW	R			RW	R	RW	RW	RW	R	RW	RW	RW	RW	RW

**Address:** Fault\_Test\_BaseAddress + 0x05

**Type:** RW

**Reset:** 0xFFFF

**Description:** Service Fault Mask register allows the user to map specific fault flags to the FAULTn pin. Setting mask bit high disables (masks) fault from setting FAULTn pin.

[15] Digital Ground Loss:

0: Mask Disabled

1: Mask Enabled

[14] Analog Ground Loss:

0: Mask Disabled

1: Mask Enabled

[13:11] Unused

[10] Fail Safe VDS Fault:

0: Mask Disabled

1: Mask Enabled

[9] Unused

[8] EEPROM Trimming data CRC error:

0: Mask Disabled

1: Mask Enabled

[7] SPI Timeout Latch:

0: Mask Disabled

1: Mask Enabled

[6] SPI Timeout:

0: Mask Disabled

1: Mask Enabled

[5] Unused

[4] VDD Under Voltage:

0: Mask Disabled

1: Mask Enabled

[3] CP Under Voltage:

0: Mask Disabled

1: Mask Enabled

[2] Configuration Register

0: Mask Disabled

1: Mask Enabled

[1] VBATP Over Voltage:

0: Mask Disabled

1: Mask Enabled

[0] Core Over Temperature:

0: Mask Disabled

1: Mask Enabled

**SERVFLTMSK2**
**Service fault mask 2**

15	14	13	12	11	10	9	8	7	6	5	4	3	2	1	0
Unused	Clamp Inhibit Monitor	Unused					SPI Protocol Error		Unused	IN 3 echo	IN 2 echo	IN 1 echo	IN 0 echo	EN_DR echo	
R	RW	R					RW		R	RW	RW	RW	RW	RW	RW

**Address:** Fault Test Base Address + 0x06

**Type:** RW

**Reset:** 0xFFFF

**Description:** Service Fault Mask register allows the user to map specific fault flags to the FAULTn pin. Setting mask bit high disables (masks) fault from setting FAULTn pin.

[15] Unused

[14] Clamp Inhibit Monitor

0: Mask Disabled

1: Mask Enabled

[13:8] Unused

[7] SPI Protocol Error

0: Mask Disabled

1: Mask Enabled

[6:5] Unused

[4] IN3

0: Mask Disabled

1: Mask Enabled

[3] IN2

0: Mask Disabled

1: Mask Enabled

[2] IN1

0: Mask Disabled

1: Mask Enabled

[1] IN0

0: Mask Disabled

1: Mask Enabled

[0] EN\_DR

0: Mask Disabled

1: Mask Enabled

**COMMUNICATIONFLTS**
**SPI communications faults**

15	14	13	12	11	10	9	8	7	6	5	4	3	2	1	0
Unused			Frame Counter Error Flag	CRC Error Flag	Short Frame Flag	Loong Frame Flag	Unused								

**Address:** Fault\_Test\_BaseAddress + 0x1D  
**Type:** R  
**Reset:** 0x0000  
**Description:** SPI communication faults monitors

- [15:13] Unused
- [12] Frame Counter Error Flag
  - 0: No Fault
  - 1: Wrong Counter Value
- [11] CRC Error Flag
  - 0: No Fault
  - 1: CRC Check Fault
- [10] Short Frame Flag
  - 0: No Fault
  - 1: Frame bits received < 16
- [9] Long Frame Flag
  - 0: No Fault
  - 1: Frame bits received > 16
- [8:0] Unused

## 9.10 Channel page registers

**Table 42. SPI channel page register address mapping**

Idx [hex]	Register
0x00	Exceptions 1
0x01	Exceptions 2
0x02	Configuration 1
0x03	Configuration 2
0x04	Dither Programming 1
0x05	Dither Programming 2
0x06	Current Set Point
0x07	Control Configuration
0x08	Frequency Control
0x09	Gains Configuration
0x0A	Integrator Limit
0x0B	Average Current
0x0C	PWM Sense
0x0D	Driver Fault Mask 1
0x0E	Driver Fault Mask 2
0x0F	Base H/L Delta Current
0x10	Measured H/L Delta Current
0x11	Temperature Monitor
0x14	Integrator Output

**EXCEPTIONS1**
**Exceptions 1**

15	14	13	12	11	10	9	8	7	6	5	4	3	2	1	0
T_WARN	EEPROM CRC error on CSA Calibration data	EEPROM CRC error on A2D trimming bits	PWM check fault	PWM check comp mismatch	Solenoid Logic BIST Status		Solenoid Diag Self Test		Open Load	Short Detection	Solenoid ADC mismatch Monitor	LS clamp active	HS over current	LS over current	T_SD
RH	R	R	RH	RH	R		RH		RH	RH	RH	RH	RH	RH	RH

**Address:** Channel\_X\_BaseAddress + 0x00

**Reset** 0x0000

**Description:** Solenoid Driver Fault Status

[15] Thermal Warning (T\_WARN):

0: No Fault  
1: Thermal Warning Present  
Clear on Read

[14] EEPROM CRC Error on CSA Calibration Data:

0: No Fault  
1: CRC Error  
Read

[13] EEPROM CRC error on A2D trimming bits:

0: No Fault  
1: CRC Error  
Read

[12] PWM Check Fault (ON State):

0: No Fault  
1: Fault  
Clear on Read

[11] PWM Check Comp Mismatch (ON State):

0: No Fault  
1: Fault  
Clear on Read

[10:9] Solenoid Logic BIST Status: (ADC mismatch, out of regulation, Solenoid driver control loop)

00: Idle

- 01: BIST running
- 10: BIST passed
- 11: BIST failed
- Read
- [8:7] Solenoid Diag Self Test (OFF State):
  - 00: Self Test pass
  - 01: DIAG\_LV comparator fail
  - 10: DIAG OL comparator fail
  - 11: Self Test fail
  - Clear on Read
- [6] Open Load (OFF State):
  - 0: No Fault
  - 1: Open load
  - Clear on Read
- [5] Short Detection (OFF State):
  - 0: No Fault
  - 1: Short Detected
  - Clear on Read
- [4] Solenoid ADC Mismatch monitor:
  - 0: No Fault
  - 1: Mismatch Fault Detected
  - Clear on Read
- [3] LS Clamp Active (ON state):
  - 0: No Fault
  - 1: LS Clamp Activated
  - Clear on Read
- [2] HS Over Current (ON State)
  - 0: No Fault
  - 1: HS Over Current
  - Clear on Read
- [1] LS Over Current (ON State)
  - 0: No Fault
  - 1: LS Over Current
  - Clear on Read
- [0] T\_SD: (Thermal Shutdown)
  - 0: No Fault
  - 1: Thermal Shutdown Fault
  - Clear on Read



**EXCEPTIONS2**
**Exceptions 2**

15	14	13	12	11	10	9	8	7	6	5	4	3	2	1	0
unused										GND_SOL loss self test	Out of regulation	GND_SOL loss fault	RAM CRC error	HS/LS compare Fault	Configuration Register Monitor
R										RH	RH	RH	RH	RH	RH

**Address:** Channel\_X\_BaseAddress + 0x01

**Type:** RH

**Reset:** 0x0000

**Description:** Solenoid Driver Fault Status

[15:6] Unused

[5] GND\_SOL Loss Self Test Status

0: Test Complete

1: Test Running

Clear on Read

[4] Out of regulation

0: No Fault

1: Out of Regulation After 8 PWM Cycles

Clear on Read

[3] GND\_SOL loss fault

0: No Fault

1: Solenoid Ground Loss Detected

Clear on Read

[2] RAM CRC error

0: No Fault

1: CRC Fault Detected on RAM Read

Clear on Read

[1] HS/LS compare Fault:

0: No Fault

1: Fault Detected

Clear on Read

[0] Configuration Register Monitor:

0: No Fault

1: Fault Detected  
Clear on Read

**CONFIGURATION1**
**Configuration 1**

15	14	13	12	11	10	9	8	7	6	5	4	3	2	1	0
unused	OFS_CMP_DIS	CALIBRATION_DIS	unused		Solenoid Logic BIST	Td_Blank	HILOAD	unused	Overcurrent threshold selection	Enable OFF Diagnosis	unused	Solenoid Load Configuration	Current Feedback Control Mode		Output Slew Rate
R	RW	RW	R		RW	RW	RW	RW	RW	RW	R	RW	RW		RW

**Address:** Channel\_X\_BaseAddress + 0x02

**Type:** RW

**Reset:** 0x0000

**Description:** Configuration Register provides information related to channel configuration

[15] Unused

[14] OFS\_CMP\_DIS:

0: Current Sense Offset Compensation Active

1: Current Sense Offset Compensation disabled

[13] CALIBRATION\_DIS:

0: Digital Current Sense Calibration Active

1: Digital Current Sense Calibration Disabled

[12:11] Unused

[10] Solenoid Logic BIST:

0: Logic BIST Reset

1: Logic BIST Enabled

[9] Td\_Blank:

0: Long Blanking Time

1: Short Blanking Time

[8] HILOAD: Current Sense Scale

0: 1.5A Max Current Range

1: 2.0A Max Current Range

[7] Unused

[6] Overcurrent threshold selection:

0: 4A Theshold

1: 5A Threshold

[5] Enable OFF Diagnosis:

- 0: Disabled (OFF)
- 1: Enabled
- [4] Unused
- [3] Solenoid Load Configuration:
  - 0: Low Side
  - 1: High Side
- [2] Current Feedback Control Mode:
  - 0: HW Feedback
  - 1: SW Feedback
- [1:0] Output Slew Rate:
  - 00: 0.4V/ $\mu$ s
  - 01: 1.0V/ $\mu$ s
  - 10: 4.0V/ $\mu$ s
  - 11: 8.0V/ $\mu$ s

## CONFIGURATION2

## Configuration 2

	15	14	13	12	11	10	9	8	7	6	5	4	3	2	1	0
	Unused														Solenoid Diag Self Test	GND_SOL loss self test
	R														RW	RW

**Address:** Channel\_X\_BaseAddress + 0x03

**Type:** RW

**Reset:** 0x0000

**Description:** Configuration Register for channel configuration self-tests. Before restarting any tests, wait for the register to return to "0"

[15:2] Unused

[1] Solenoid Diag Self Test: Short, Open Load and PWM Check

0: Self Test Disabled

1: Self Test Enabled

[0] GND\_SOL loss self test

0: Self TestDisabled

1: Self Test Enabled

**DITHPGM1**
**Dither programming 1**

15	14	13	12	11	10	9	8	7	6	5	4	3	2	1	0
Dither Enable	DITHER_SYNC_EN	SYNC TYPE	Unused					Istep							
RW	RW	RW	R					RW							

**Address:** Channel\_X\_BaseAddress + 0x04

**Type:** RW

**Reset:** 0x0050

**Description:** Dither Generator Configuration

[15] Dither Enable:

0: Disabled

1: Enabled

[14] DITHER\_SYNC\_EN:

0: Disabled

1: Enabled

[13] SYNC TYPE:

0: Dither Synchronization at each Dither Step

1: Dither Synchronization at each dither Period

[12:8] Unused

[7:0] Istep: Current step Value

**DITHPGM2**
**Dither programming 2**

15	14	13	12	11	10	9	8	7	6	5	4	3	2	1	0
Unused		Nstep						Unused		Tstep					
R		RW						R		RW					

**Address:** Channel\_X\_BaseAddress + 0x05  
**Type:** RW  
**Reset:** 0x028A  
**Description:** Dither Generator Configuration

- [15:13] Unused
- [12:8] Nstep: Number of steps in a quarter of dither period
- [7:6] Unused
- [5:0] Tstep: Number of PWM cycles for each dither step

**SETPOINT**
**Current set point**

15	14	13	12	11	10	9	8	7	6	5	4	3	2	1	0
Auto Limit	unused		Current Set Point code												
RW	R		RW												

**Address:** Channel\_X\_BaseAddress + 0x06  
**Type:** RW  
**Reset:** 0x0000  
**Description:** Register stores current setpoint code (HW mode current control). Current Control SETPOINT is coded into 13 bits. Current value depends on HILOAD bit.

- [15] Auto Limit: Activates the transient mode on set point change
  - 0: Inactive
  - 1: Active
- [14:13] Unused
- [12:0] Current Set Point Code

**CTRLCFG**
**Control configuration**

15	14	13	12	11	10	9	8	7	6	5	4	3	2	1	0		
Transition Time		Unused		HW Feedback Frequency Mode												Target PWM Period Code	
RW		R		RW												RW	

**Address:** Channel\_X\_BaseAddress + 0x07

**Type:** RW

**Reset:** 0x0000

**Description:**

[15:14] Transition Time: Too long period detection (if the current PWM time exceeds this threshold, the controller enters the transient state):

00: 2.5 \* Tpwm

01 : 4.5 \* Tpwm

10: 8.5 \* Tpwm

11 : 16.5 \* Tpwm

[13:12] Unused

[11] HW feedback Frequency Mode:

0: Fixed Frequency

1: Variable Frequency

[10:0] Target PWM Period Code



**KFREQCTRL**
**Frequency control**

15	14	13	12	11	10	9	8	7	6	5	4	3	2	1	0
Unused										KFI			FINT_START		
R										RW			RW		

**Address:** Channel\_X\_BaseAddress + 0x08  
**Type:** RW  
**Reset:** 0x002F  
**Description:** Register stores KF, FCIL (Variable frequency forward gain: HW mode current control)

- [15:6] unused
- [5:3] KFI: Integral Gain of Frequency Control Loop
- [2:0] FINT\_START: Start value for frequency integrator upon exiting transient mode

**KGAINS**
**Gains configuration**

15	14	13	12	11	10	9	8	7	6	5	4	3	2	1	0
Unused										KI		KP			
R										RW		RW			

**Address:** Channel\_X\_BaseAddress + 0x09  
**Type:** RW  
**Reset:** 0x0024  
**Description:** Register stores KI (Integral error gain: HW mode current control) and KP (Proportional error gain: HW mode current control).

- [15:6] unused
- [5:3] KI: Integral Gain of HW current control loop (fixed & variable freq.)
- [2:0] KP: Proportional Gain of HW current control loop (fixed freq. only)

**INTGLIM**

Integrator limit

15	14	13	12	11	10	9	8	7	6	5	4	3	2	1	0
INT_OUT_SEL	unused					NEGINTLIM					POSINTLIM				
RW	R					RW					RW				

**Address:** Channel\_X\_BaseAddress + 0x0A

**Type:** RW

**Reset:** 0x0000

**Description:** --

[15:14] INT\_OUT\_SEL:  
 00: Integrator Low Threshold  
 01: Integrator High Threshold  
 10: Integrator Min Level  
 11: Integrator Max Level

[13:8] Unused

[7:4] NEGINTLIM

[3:0] POSINTLIM

**AVGCUR**

Average current

15	14	13	12	11	10	9	8	7	6	5	4	3	2	1	0
Unused		AVGCUR													

**Address:** Channel\_X\_BaseAddress + 0x0B

**Type:** R

**Reset:** 0x0000

**Description:** Stores Average Current Code in 1 PWM period

[15:14] Unused

[13:0] AVGCUR: Average current code (signed) in 1 PWM period

## PWMSENSE

PWM sense

	15	14	13	12	11	10	9	8	7	6	5	4	3	2	1	0	
TMOUT									PWM Code								
RH									R								

**Address:** Channel\_X\_BaseAddress + 0x0C

**Type:** RH

**Reset:** 0x0000

**Description:** PWM period out of range flag (TMOUT). PWM code: measured effective PWM period

[15] TMOUT

0: No Fault

1: Fault Detected

Clear on Read

[14:0] PWM Code

**DRVFLTMASK1**
**Driver fault mask 1**

15	14	13	12	11	10	9	8	7	6	5	4	3	2	1	0
E_SOL_TW	EEPROM CRC Error on CSA Calibration Data Mask	EEPROM CRC Error on A2D Trimming Bits Mask	PWM check fault	PWM Check Comp Mismatch	Unused				E_SOL_OL	E_SOL_SHORT	E_SOL_A2D	E_LSCLAMP	E_SOL_HSOVC	E_SOL_LSOVC	E_SOL_OT
RW	RW	RW	RW	RW			R		RW	RW	RW	RW	RW	RW	RW

**Address:** Channel\_X\_BaseAddress + 0x0D

**Type:** RW

**Reset:** 0xFFFF

**Description:** Driver Fault Mask register is an active High Mask register for Driver Faults. Setting mask bit disables corresponding fault from generating interrupt on FAULT pin.

- [15] E\_SOL\_TW: Solenoid Driver Thermal Warning  
0: NOT Masked  
1: MASKED
- [14] EEPROM CRC error on CSA Calibration data Mask:  
0: NOT Masked  
1: MASKED
- [13] EEPROM CRC error on A2D trimming bits Mask:  
0: NOT Masked  
1: MASKED
- [12] PWM Check Fault:  
0: NOT Masked  
1: MASKED
- [11] PWM Check Comp Mismatch:  
0: NOT Masked  
1: MASKED
- [10:7] Unused

- [6] E\_SOL\_OL: Open Load Fault Mask
  - 0: NOT Masked
  - 1: MASKED
- [5] E\_SOL\_SHORT: Solenoid Short Fault Mask
  - 0: NOT Masked
  - 1: MASKED
- [4] E\_SOL\_A2D: Solenoid ADC Mismatch Fault Mask
  - 0: NOT Masked
  - 1: MASKED
- [3] E\_LSCLAMP: Low Side Clamp Active Fault Mask
  - 0: NOT Masked
  - 1: MASKED
- [2] E\_SOL\_HSOVC: High Side Over Current Fault Mask
  - 0: NOT Masked
  - 1: MASKED
- [1] E\_SOL\_LSOVC: Low Side Over Current Fault Mask
  - 0: NOT Masked
  - 1: MASKED
- [0] E\_SOL\_OT: Solenoid Driver Over Temperature Fault Mask
  - 0: NOT Masked
  - 1: MASKED

**DRVFLTMASK2**
**Driver fault mask 2**

15	14	13	12	11	10	9	8	7	6	5	4	3	2	1	0
Unused											Out of regulation	GND_SOL loss fault	E_RAM_CRC_ERR	E_SOL_HS/LS	E_CFG_REG_FAIL
R											RW	RW	RW	RW	RW

**Address:** Channel\_X\_BaseAddress + 0x0E

**Type:** RW

**Reset:** 0xFFFF

**Description:** Driver Fault Mask register is an active Hi Mask register for Driver Faults. Setting mask bit disables corresponding fault from generating interrupt on FAULT pin

[15:5] unused

[4] Out of regulation

0: NOT Masked

1: MASKED

[3] GND\_SOL loss fault

0: NOT Masked

1: MASKED

[2] RAM CRC error

0: NOT Masked

1: MASKED

[1] E\_SOL\_HS/LS:

0: NOT Masked

1: MASKED

[0] E\_CFG\_REG\_FAIL:

0: NOT Masked

1: MASKED

**BSHLDELTA Curr**
**Base H/L delta current**

15	14	13	12	11	10	9	8	7	6	5	4	3	2	1	0
Unused								Base Delta Current							
R								RW							

**Address:** Channel\_X\_BaseAddress + 0x0F  
**Type:** RW  
**Reset:** 0x0000  
**Description:** Base High Side/Low Side Delta Current

- [15:8] Unused
- [7:0] Base Delta Current: Base High Side/Low Side Delta Current

## MEASHLDELTA Curr

Measure H/L delta current

15	14	13	12	11	10	9	8	7	6	5	4	3	2	1	0
unused								Meas Delta Current							
R								RW							

**Address:** Channel\_X\_BaseAddress + 0x10

**Type:** R

**Reset:** 0x0000

**Description:** Measured H/L Delta current

[15:8] Unused

[7:0] Measured Base Delta Current Between High & Low Side



## TEMPMON

Temperature monitor

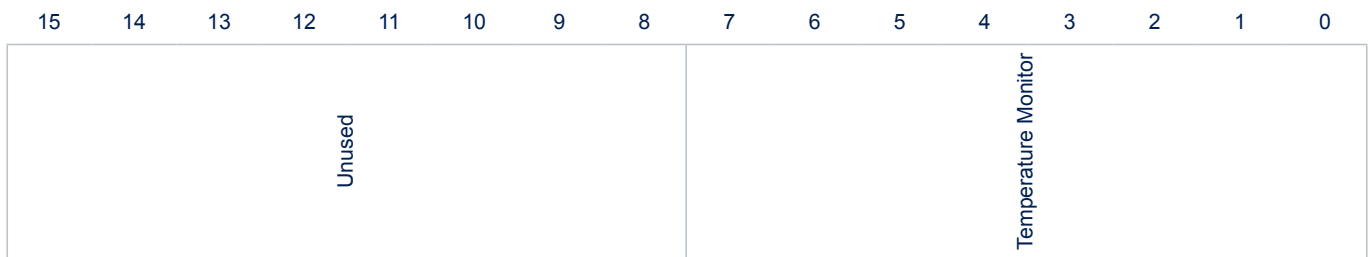

**Address:** Channel\_X\_BaseAddress + 0x11  
**Type:** R  
**Reset:** 0x0000  
**Description:** Temperature Monitor

[15:8] Unused  
 [7:0] Temperature Monitor: Unsigned

## INTOUT

Integrator output



**Address:** Channel\_X\_BaseAddress + 0x14  
**Type:** R  
**Reset:** 0x0000  
**Description:** Integrator Output Monitor

[15:0] Integrator Output Monitor: Unsigned

## 10 Package information

In order to meet environmental requirements, ST offers these devices in different grades of **ECOPACK** packages, depending on their level of environmental compliance. ECOPACK specifications, grade definitions and product status are available at: [www.st.com](http://www.st.com). ECOPACK is an ST trademark.

### 10.1 TQFP48 (7x7x1 mm exp. pad down 5.0x5.0) package information

Figure 28. TQFP48 (7x7x1 mm exp. pad down 5.0x5.0) package outline

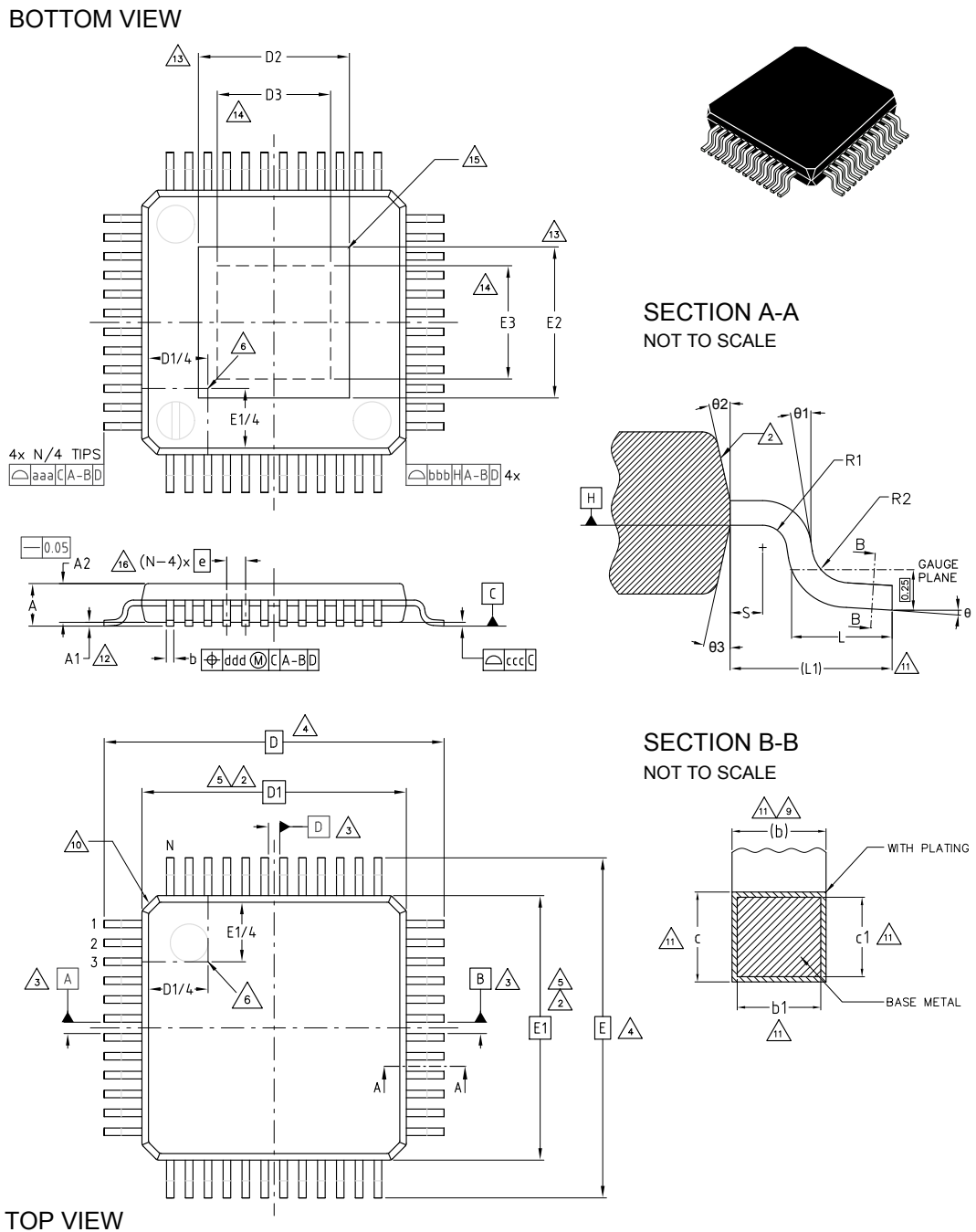

**Table 43. TQFP48 (7x7x1 mm exp. pad down 5.0x5.0) package mechanical data**

Symbol	Dimensions			Note
	Min.	Typ.	Max.	
Θ	0°	3.5°	7°	
Θ1	0°			
Θ2	11°	12°	13°	
Θ3	11°	12°	13°	
A			1.20	15
A1	0.05		0.15	12
A2	0.95	1.00	1.05	15
b	0.17	0.22	0.27	9, 11
b1	0.17	0.20	0.23	11
c	0.09		0.20	11
c1	0.09		0.16	11
D	9.00 BSC			4
D1	7.00 BSC			2, 5
D2			5.37	13
D3	3.4			14
e	0.50 BSC			
E	9.00 BSC			4
E1	7.00 BSC			2, 5
E2			5.37	13
E3	3.4			14
L	0.45	0.60	0.75	
L1	1.00 REF			
N	48			16
R1	0.08			
R2	0.08		0.20	
S	0.20			
<b>Tolerance of form and position</b>				
aaa	0.20			1, 7
bbb	0.20			
ccc	0.08			
ddd	0.08			

**Notes:**

1. Dimensioning and tolerancing schemes conform to ASME Y14.5M-1994.
2. The top package body size may be smaller than the bottom package size up to 0.15 mm.
3. Datum A-B and D to be determined at datum plane H.
4. To be determined at seating datum plane C.
5. Dimensions D1 and E1 do not include mold flash or protrusions. Allowable mold flash or protrusions is "0.25 mm" per side. D1 and E1 are maximum plastic body size dimensions including mold mismatch.
6. Details of pin 1 identifier are optional but must be located within the zone indicated.
7. All dimensions are in millimeters.

8. No intrusion allowed inwards the leads.
9. Dimension "b" does not include dambar protrusion. Allowable dambar protrusion shall not cause the lead width to exceed the maximum "b" dimension by more than 0.08 mm. Dambar cannot be located on the lower radius or the foot. Minimum space between protrusion and an adjacent lead is 0.07 mm for 0.4 mm and 0.5 mm pitch packages.
10. Exact shape of each corner is optional.
11. These dimensions apply to the flat section of the lead between 0.10 mm and 0.25 mm from the lead tip.
12. A1 is defined as the distance from the seating plane to the lowest point on the package body.
13. Dimensions D2 and E2 show the maximum exposed metal area on the package surface where the exposed pad is located (if present). It includes all metal protrusions from exposed pad itself.
14. Dimensions D3 and E3 show the minimum solderable area, defined as the portion of exposed pad which is guaranteed to be free from resin flashes/bleeds, bordered by internal edge of inner groove.
15. The optional exposed pad is generally coincident with the top or bottom side of the package and not allowed to protrude beyond that surface.
16. "N" is the number of terminal positions for the specified body size.

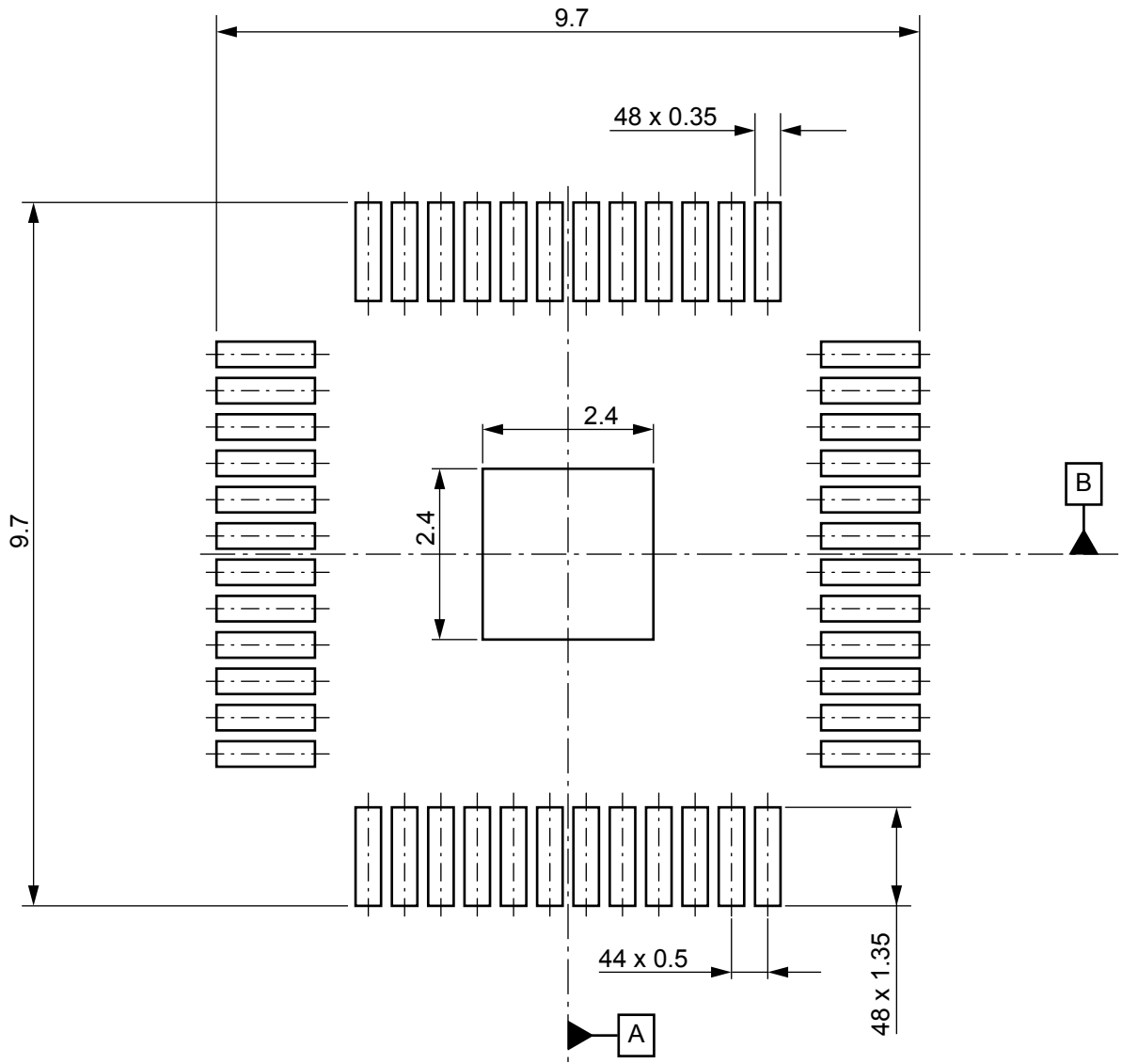
**10.2 TQFP48 (7x7x1.0 exposed pad down) footprint**
**Figure 29. TQFP48 (7x7x1.0 exposed pad down) footprint**

**Notes:**

- 1) This footprint is able to ensure insulation up to 20 Vrms (according to CEI IEC 664-1)
- 2) The device must be positioned within  $\oplus 0.02$  A B

GADG0810180810PS

### 10.3 TQFP48 marking information

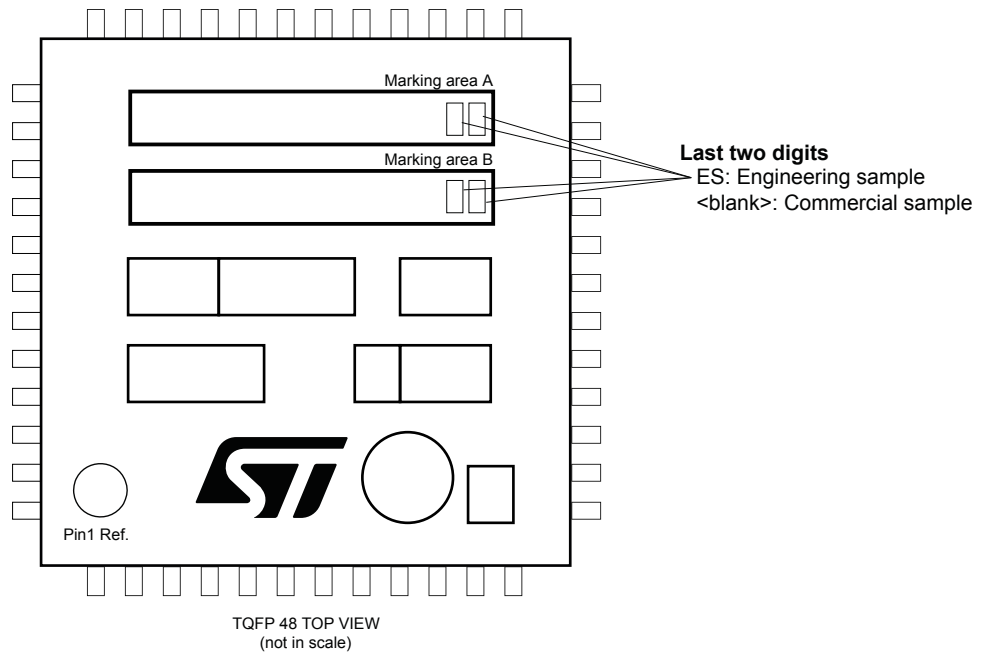
Figure 30. TQFP48 marking information



GADG0810181047PS\_ES

Parts marked as 'ES' are not yet qualified and therefore not approved for use in production. ST is not responsible for any consequences resulting from such use. In no event will ST be liable for the customer using any of these engineering samples in production. ST's Quality department must be contacted prior to any decision to use these engineering samples to run a qualification activity.

## 10.4 PowerSSO-36 (7.2x4.75 mm option C exposed pad down) package information

**Figure 31. PowerSSO-36 (7.2x4.75 mm option C exposed pad down) package outline**

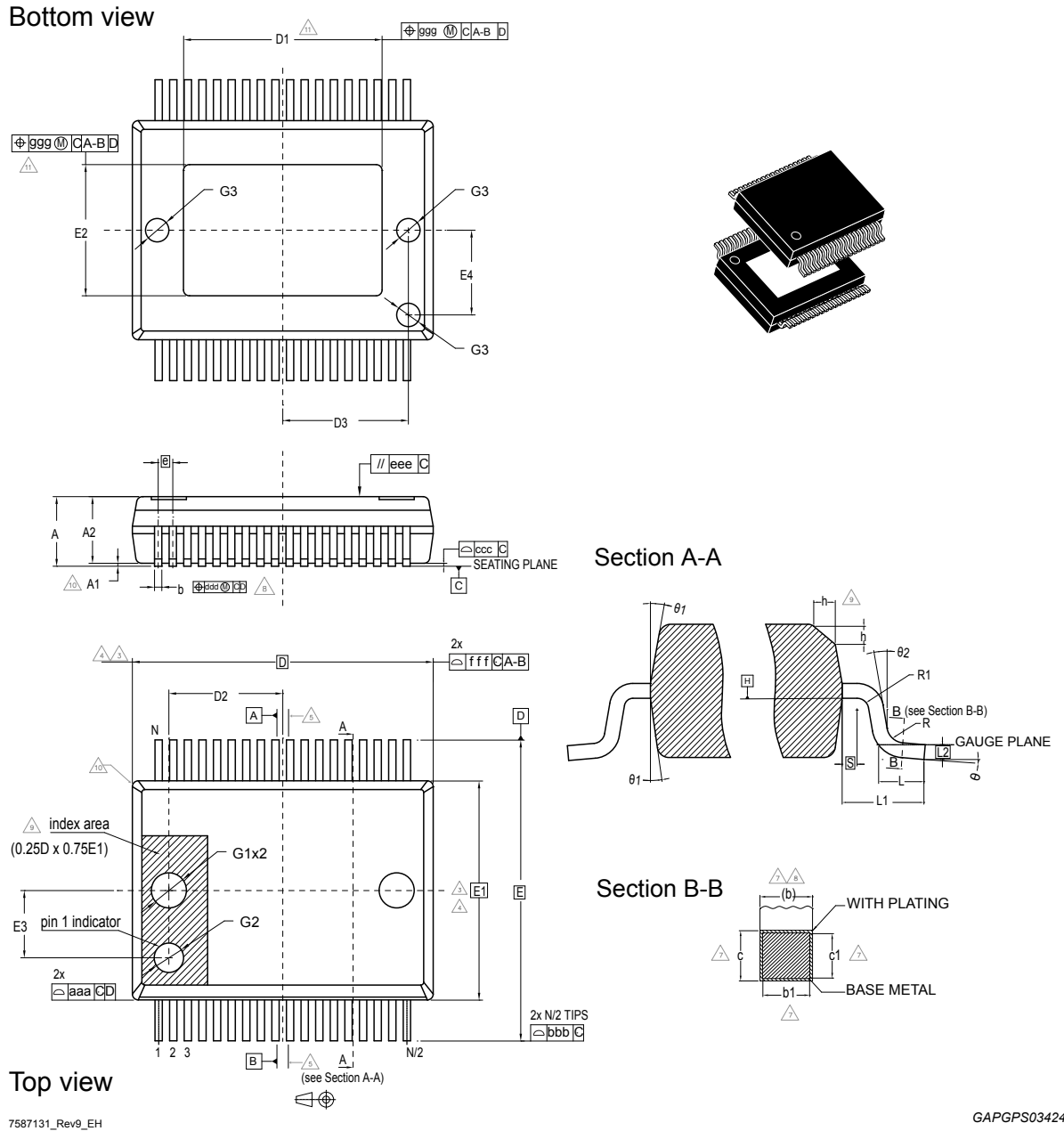

**Table 44. PowerSSO-36 (exposed pad down) package mechanical data**

Symbol	Dimensions			Note
	Min.	Typ.	Max.	
$\Theta$	0°	-	8°	
$\Theta 1$	5°	-	10	
$\Theta 2$	0°	-	-	
A	2.15	-	2.45	



Symbol	Dimensions			Note
	Min.	Typ.	Max.	
A1	0.00	-	0.10	10
A2	2.15	-	2.35	
b	0.18	-	0.32	7, 8
b1	0.13	0.2	0.30	7, 8
c	0.23	-	0.32	7
c1	0.20	0.20	0.30	7
D	10.30 BSC			3, 4
D1	<b>VARIATION</b>			11
D2	-	3.65	-	
D3	-	4.30	-	
e	0.50 BSC			
E	10.30 BSC			
E1	7.50 BSC			3, 4
E2	<b>VARIATION</b>			11
E3	-	2.30	-	
E4	-	2.90	-	
G1	-	1.20	-	
G2	-	1.00	-	
G3	-	0.80	-	
h	0.30	-	0.40	9
L	0.55	0.70	0.85	
L1	1.40 REF			
L2	0.20 BSC			
N	36			6
R1	0.30	-	-	
R2	0.20	-	-	
S	0.25	-	-	
<b>Tolerance of form and position</b>				
aaa	0.20			1, 2
bbb	0.20			
ccc	0.08			
ddd	0.08			
eee	0.10			
fff	0.20			
ggg	0.15			
<b>VARIATIONS</b>				
D1	6.50	-	7.10	A
E2	4.10	-	4.70	
D1	4.90	-	5.50	B
E2	4.10	-	4.70	

Symbol	Dimensions			Note
	Min.	Typ.	Max.	
D1	6.90	-	7.50	C
E2	4.30	-	5.20	

**Notes:**

1. Dimensioning and tolerancing schemes conform to ASME Y14.5M-1994.
2. All dimensions are in millimeters.
3. Dimensions D and E1 do not include mold flash or protrusions. Allowable mold flash or protrusions is "0.25 mm" per side D and "0.15 mm" per side E1. D and E1 are Maximum plastic body size dimensions including mold mismatch.
4. The top package body size may be smaller than the bottom package size.
5. Datum A-B and D to be determined at datum plane H.
6. "N" is the max number of terminal positions for the specified body size.
7. The dimensions apply to the flat section of the lead between 0.10 to 0.25 mm from the lead tip.
8. Dimension "b" does not include dambar protrusion. Allowable dambar protrusion shall be 0.10 mm total in exceed of the "b" dimension at maximum material condition. The dambar cannot be located on the lower radius of the foot.
9. This Chamfer feature is optional. If it is not present, then a PIN 1 identifier must be located within the index area indicated.
10. A1 is defined as the vertical distance from the seating plane to the lowest point on the package body.
11. Dimension D1 and E2 show the minimum allowed for the optional exposed pad. The size of exposed pad is variable depending of leadframe design pad size. End user should verify "D1" and "E2" dimensions for each device application.

## 10.5 PowerSSO-36 marking information

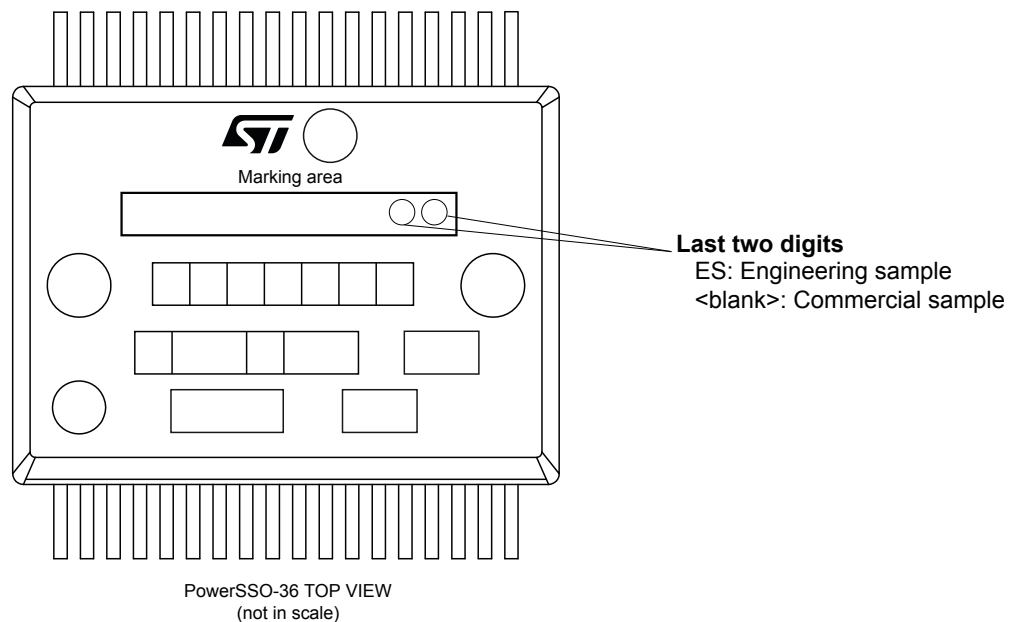
**Figure 32. PowerSSO-36 marking information**

GAPG2904151300PS\_ES

Parts marked as 'ES' are not yet qualified and therefore not approved for use in production. ST is not responsible for any consequences resulting from such use. In no event will ST be liable for the customer using any of these engineering samples in production. ST's Quality department must be contacted prior to any decision to use these engineering samples to run a qualification activity.

## Revision history

**Table 45. Document revision history**

Date	Version	Changes
12-Dec-2018	1	Initial release.
29-Mar-2019	2	Updated: Section Product status / summary; Section Features.
17-Jul-2019	3	The confidentiality level is changed from "Restricted" to "Public".
12-Feb-2020	4	Updated: Section Features and Product summary; Section 5.7 GND (GNDD, GNDA, GND_SOLx); Table 4. Device operating temperature; Table 33. Valve driver safety parameters.
06-Jul-2020	5	Updated Table 4. Device operating temperature; Minor text changes in Features.
17-Dec-2020	6	Updated: Section 9.8.5 CHIPID; Section 9.10.3 CONFIGURATION1. Minor text changes in Section 8.4.1 High side – low side current sense compare.
11-May-2021	7	Minor text changes in Section 6.1.8 Parallel mode.
25-Nov-2021	8	Typo corrections.

## Contents

<b>1</b>	<b>Block diagram</b> .....	<b>3</b>
<b>2</b>	<b>Pins description</b> .....	<b>6</b>
<b>3</b>	<b>Product Characteristics</b> .....	<b>9</b>
3.1	Absolute maximum ratings .....	9
3.2	Latchup trials .....	9
3.3	ESD performance .....	10
3.4	Temperature range .....	10
<b>4</b>	<b>Input / Output</b> .....	<b>11</b>
4.1	Reset (RESn) .....	11
4.2	Enable (EN_DR) .....	11
4.3	Channel inputs (INx/NDISx) .....	11
4.4	Fault (FAULTn) .....	11
4.5	SPI communications (CS, SCLK, MOSI & MISO) .....	12
4.6	Input / output electrical specifications .....	13
<b>5</b>	<b>Power supply</b> .....	<b>14</b>
5.1	Overview .....	14
5.2	Battery supply (VBATP) .....	14
5.3	Load supplies (VSOL1, VSOL2, VSOL3 & VSOL4) .....	14
5.4	Analog and digital supply (VDD) .....	15
5.5	I/O supply (VDDIO) .....	15
5.6	Power-On reset .....	15
5.7	GND (GNDD, GNDA, GND_SOLx) .....	15
5.8	Charge pump .....	15
5.9	Startup & power down sequence .....	16
5.10	Power supply electrical specifications .....	17
<b>6</b>	<b>Current control drivers</b> .....	<b>18</b>
6.1	Hardware current control .....	18
6.1.1	Current set point programming .....	20
6.1.2	PWM switching period programming .....	20

6.1.3	Current control loop configuration . . . . .	20
6.1.4	Fixed frequency control . . . . .	21
6.1.5	Variable frequency control . . . . .	22
6.1.6	Chopper offset compensation of current sense amplifier . . . . .	24
6.1.7	Staggered channel activation . . . . .	24
6.1.8	Parallel mode . . . . .	24
6.1.9	Dither programming . . . . .	25
6.1.10	Dither synchronization . . . . .	26
<b>6.2</b>	<b>Software current control . . . . .</b>	<b>26</b>
<b>6.3</b>	<b>Solenoid current control feedback . . . . .</b>	<b>27</b>
6.3.1	Average current . . . . .	27
6.3.2	Integrator feedback . . . . .	28
6.3.3	Solenoid PWM period feedback . . . . .	28
6.3.4	Out of regulation flag . . . . .	28
<b>6.4</b>	<b>Solenoid driver and load diagnostic . . . . .</b>	<b>29</b>
6.4.1	Thermal protection . . . . .	29
6.4.2	Overcurrent protection . . . . .	29
6.4.3	Supply disconnection . . . . .	29
6.4.4	Off state solenoid diagnostics . . . . .	29
<b>6.5</b>	<b>Valve driver electrical specifications . . . . .</b>	<b>31</b>
<b>7</b>	<b>High side fail safe pre-driver . . . . .</b>	<b>35</b>
7.1	Fail safe predriver diagnostic . . . . .	36
7.2	Fail safe predriver electrical characteristics . . . . .	36
<b>8</b>	<b>Safety features . . . . .</b>	<b>38</b>
8.1	Power supply monitoring and diagnostics . . . . .	39
8.1.1	VDD over and under voltage diagnostics . . . . .	39
8.1.2	VBATP supply over voltage . . . . .	39
8.1.3	VCP supply under voltage . . . . .	39
8.1.4	Bandgap regulators, internal analog and digital supply monitoring . . . . .	40
8.1.5	GND loss detection . . . . .	40
8.1.6	Power supply monitoring and diagnostics electrical characteristics . . . . .	41
8.2	Main & reference oscillators . . . . .	42

8.2.1	Main and reference oscillators electrical characteristics .....	42
<b>8.3</b>	<b>Safety switch-off path .....</b>	<b>42</b>
8.3.1	Safety switch-off path electrical characteristics .....	43
<b>8.4</b>	<b>Valve drivers .....</b>	<b>43</b>
8.4.1	High side – low side current sense compare .....	43
8.4.2	Solenoid current control ADC check .....	44
8.4.3	Digital control loop logic BIST .....	44
8.4.4	Calibration data check .....	44
8.4.5	Diagnostic comparators .....	44
8.4.6	PWM check .....	45
8.4.7	Valve driver safety electrical characteristics .....	45
<b>8.5</b>	<b>Core over temperature .....</b>	<b>45</b>
8.5.1	Core over temperature electrical characteristics .....	46
<b>8.6</b>	<b>IC data verification .....</b>	<b>46</b>
<b>9</b>	<b>SPI .....</b>	<b>47</b>
9.1	SPI protocol .....	47
9.2	CRC .....	49
9.3	SPI errors management .....	49
9.4	SPI timeout monitoring function .....	49
9.5	SPI channel exception field .....	50
9.6	SPI electrical specification .....	51
9.7	SPI registers map table .....	52
9.8	Global page .....	52
9.9	Fault and test page summary .....	59
9.10	Channel page registers .....	70
<b>10</b>	<b>Package information .....</b>	<b>91</b>
10.1	TQFP48 (7x7x1 mm exp. pad down 5.0x5.0) package information .....	91
10.2	TQFP48 (7x7x1.0 exposed pad down) footprint .....	94
10.3	TQFP48 marking information .....	95
10.4	PowerSSO-36 (7.2x4.75 mm option C exposed pad down) package information .....	96
10.5	PowerSSO-36 marking information .....	98

Revision history ..... 100



## List of tables

<b>Table 1.</b>	PowerSSO-36 and TQFP48 pins list . . . . .	7
<b>Table 2.</b>	Absolute maximum ratings . . . . .	9
<b>Table 3.</b>	ESD Performance . . . . .	10
<b>Table 4.</b>	Device operating temperature . . . . .	10
<b>Table 5.</b>	Global and external supply fault pin error masking . . . . .	11
<b>Table 6.</b>	Solenoid channel and fail safe fault pin error masking . . . . .	12
<b>Table 7.</b>	Digital input/output electrical performance . . . . .	13
<b>Table 8.</b>	VBATP electrical performance . . . . .	14
<b>Table 9.</b>	Power supply electrical performance . . . . .	17
<b>Table 10.</b>	Solenoid driver status in hardware mode . . . . .	19
<b>Table 11.</b>	PWM period and Frequency Programming . . . . .	20
<b>Table 12.</b>	Solenoid driver channel status in hardware mode . . . . .	26
<b>Table 13.</b>	INx polarity . . . . .	27
<b>Table 14.</b>	LS diagnostic truth table . . . . .	31
<b>Table 15.</b>	HS diagnostic truth table . . . . .	31
<b>Table 16.</b>	Valve driver power stage electrical parameters . . . . .	31
<b>Table 17.</b>	Current control electrical parameters . . . . .	32
<b>Table 18.</b>	Valve driver on state diagnostics parameters . . . . .	33
<b>Table 19.</b>	Valve driver LS off state diagnostics parameters . . . . .	34
<b>Table 20.</b>	Valve Driver HS Off State Diagnostic Parameters . . . . .	34
<b>Table 21.</b>	Fail safe predriver electrical parameters . . . . .	36
<b>Table 22.</b>	Safety monitors and self test summary . . . . .	38
<b>Table 23.</b>	VDD Fault Summary . . . . .	39
<b>Table 24.</b>	VBATP Fault Summary . . . . .	39
<b>Table 25.</b>	Charge pump fault summary . . . . .	39
<b>Table 26.</b>	POR fault summary . . . . .	40
<b>Table 27.</b>	GNDA and GNDD fault summary . . . . .	40
<b>Table 28.</b>	Solenoid GND fault summary . . . . .	40
<b>Table 29.</b>	Power supply monitoring electrical performance . . . . .	41
<b>Table 30.</b>	Main and reference oscillator safety parameters . . . . .	42
<b>Table 31.</b>	Oscillator safety switch-off path parameter . . . . .	43
<b>Table 32.</b>	NVM memory map . . . . .	44
<b>Table 33.</b>	Valve driver safety parameters . . . . .	45
<b>Table 34.</b>	Core thermal monitoring electrical performance . . . . .	46
<b>Table 35.</b>	SPI time out values . . . . .	50
<b>Table 36.</b>	Reset latch enable state . . . . .	50
<b>Table 37.</b>	Time out reset latch counter values . . . . .	50
<b>Table 38.</b>	SPI electrical parameters . . . . .	51
<b>Table 39.</b>	SPI page address mapping . . . . .	52
<b>Table 40.</b>	SPI global page register address mapping . . . . .	52
<b>Table 41.</b>	SPI fault and test page register address mapping . . . . .	59
<b>Table 42.</b>	SPI channel page register address mapping . . . . .	70
<b>Table 43.</b>	TQFP48 (7x7x1 mm exp. pad down 5.0x5.0) package mechanical data . . . . .	92
<b>Table 44.</b>	PowerSSO-36 (exposed pad down) package mechanical data . . . . .	96
<b>Table 45.</b>	Document revision history . . . . .	100

## List of figures

<b>Figure 1.</b>	Block diagram . . . . .	3
<b>Figure 2.</b>	PWSSO36 application schematic . . . . .	4
<b>Figure 3.</b>	TQFP48 application schematic . . . . .	5
<b>Figure 4.</b>	PowerSSO-36 pinout diagram . . . . .	6
<b>Figure 5.</b>	TQFP48 pinout diagram . . . . .	6
<b>Figure 6.</b>	Charge pump mechanization . . . . .	16
<b>Figure 7.</b>	Startup procedure example . . . . .	16
<b>Figure 8.</b>	HS driver (left) and LS driver (right) configuration . . . . .	18
<b>Figure 9.</b>	Hardware control configuration . . . . .	19
<b>Figure 10.</b>	Fixed frequency algorithm . . . . .	21
<b>Figure 11.</b>	Fixed frequency signals . . . . .	22
<b>Figure 12.</b>	Variable frequency algorithm . . . . .	23
<b>Figure 13.</b>	Dither waveforms definitions . . . . .	25
<b>Figure 14.</b>	Software control configuration . . . . .	26
<b>Figure 15.</b>	Low side configuration diagnostic . . . . .	30
<b>Figure 16.</b>	High side configuration diagnostic . . . . .	30
<b>Figure 17.</b>	Fail safe concept . . . . .	35
<b>Figure 18.</b>	Oscillator monitor . . . . .	42
<b>Figure 19.</b>	HS/LS current compare example . . . . .	43
<b>Figure 20.</b>	ADC check block diagram . . . . .	44
<b>Figure 21.</b>	SPI Frame Format . . . . .	47
<b>Figure 22.</b>	Out of frame response . . . . .	47
<b>Figure 23.</b>	SPI frame after Power On Reset . . . . .	48
<b>Figure 24.</b>	Clear on Read SPI sequence . . . . .	48
<b>Figure 25.</b>	SPI write sequence . . . . .	48
<b>Figure 26.</b>	SPI frame with error on previous SPI frame . . . . .	49
<b>Figure 27.</b>	SPI timings, thresholds 20% to 80% and viceversa . . . . .	52
<b>Figure 28.</b>	TQFP48 (7x7x1 mm exp. pad down 5.0x5.0) package outline . . . . .	91
<b>Figure 29.</b>	TQFP48 (7x7x1.0 exposed pad down) footprint . . . . .	94
<b>Figure 30.</b>	TQFP48 marking information . . . . .	95
<b>Figure 31.</b>	PowerSSO-36 (7.2x4.75 mm option C exposed pad down) package outline . . . . .	96
<b>Figure 32.</b>	PowerSSO-36 marking information . . . . .	98

**IMPORTANT NOTICE – PLEASE READ CAREFULLY**

STMicroelectronics NV and its subsidiaries (“ST”) reserve the right to make changes, corrections, enhancements, modifications, and improvements to ST products and/or to this document at any time without notice. Purchasers should obtain the latest relevant information on ST products before placing orders. ST products are sold pursuant to ST’s terms and conditions of sale in place at the time of order acknowledgement.

Purchasers are solely responsible for the choice, selection, and use of ST products and ST assumes no liability for application assistance or the design of Purchasers’ products.

No license, express or implied, to any intellectual property right is granted by ST herein.

Resale of ST products with provisions different from the information set forth herein shall void any warranty granted by ST for such product.

ST and the ST logo are trademarks of ST. For additional information about ST trademarks, please refer to [www.st.com/trademarks](http://www.st.com/trademarks). All other product or service names are the property of their respective owners.

Information in this document supersedes and replaces information previously supplied in any prior versions of this document.

© 2021 STMicroelectronics – All rights reserved

## X-ON Electronics

Largest Supplier of Electrical and Electronic Components

*Click to view similar products for [Gate Drivers](#) category:*

*Click to view products by [STMicroelectronics](#) manufacturer:*

Other Similar products are found below :

[00053P0231](#) [56956](#) [57.404.7355.5](#) [LT4936](#) [57.904.0755.0](#) [5882900001](#) [00600P0005](#) [00-9050-LRPP](#) [00-9090-RDPP](#) [5951900000](#) [01-1003W-10/32-15](#) [0131700000](#) [00-2240](#) [LTP70N06](#) [LVP640](#) [5J0-1000LG-SIL](#) [LY1D-2-5S-AC120](#) [LY2-US-AC240](#) [LY3-UA-DC24](#) [00576P0020](#) [00600P0010](#) [LZN4-UA-DC12](#) [LZNQ2M-US-DC5](#) [LZNQ2-US-DC12](#) [LZP40N10](#) [00-8196-RDPP](#) [00-8274-RDPP](#) [00-8275-RDNP](#) [00-8609-RDPP](#) [00-8722-RDPP](#) [00-8728-WHPP](#) [00-8869-RDPP](#) [00-9051-RDPP](#) [00-9091-LRPP](#) [00-9291-RDPP](#) [0207100000](#) [0207400000](#) [60100564](#) [01312](#) [0134220000](#) [60713816](#) [M15730061](#) [61161-90](#) [61278-0020](#) [6131-204-23149P](#) [6131-205-17149P](#) [6131-209-15149P](#) [6131-218-17149P](#) [6131-220-21149P](#) [6131-260-2358P](#)