

All silicon voltage regulator

Datasheet - production data

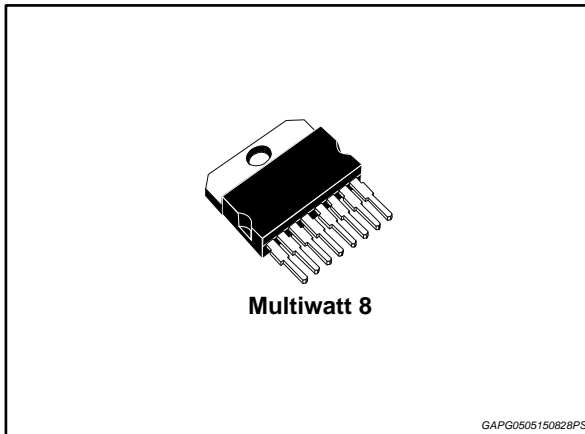

- Overvoltage protection
- Complex diagnostics
- Load Response Control

Description

The L9474N is a monolithic multifunction generator voltage regulator intended for use in automotive applications.

This device regulates the output of an automotive generator by controlling the field winding current by means of a variable frequency PWM high side driver.

The setpoint voltage reference is selected by the ENGINE CONTROL UNIT via RVC protocol.

Features

- High side field driver
- Thermal protection
- Field driver short circuit protection
- RVC interface

Table 1: Device summary

Order code	Package	Packing
L9474N	Multiwatt 8	Tube

Contents

- 1 Schematic diagram and pin description 5**
 - 1.1 Schematic diagram 5
 - 1.2 Pin description..... 5
- 2 Electrical specification..... 6**
 - 2.1 Absolute maximum ratings 6
 - 2.2 Thermal data 6
 - 2.3 Electrical characteristic 6
 - 2.4 Diagnostic 8
 - 2.5 Fault 8
 - 2.6 Regulation features 8
- 3 Package information 10**
 - 3.1 Multiwatt 8 (pin 5 GND) package information..... 10
- 4 Revision history 12**

List of tables

Table 1: Device summary	1
Table 2: Pin description	5
Table 3: Absolute maximum ratings	6
Table 4: Thermal data.....	6
Table 5: Electrical characteristic	6
Table 6: Diagnostic	8
Table 7: Fault driver to function list condition	8
Table 8: Regulation features.....	8
Table 9: Multiwatt 8 (pin 5GND) package mechanical drawing.....	11
Table 10: Document revision history	12

List of figures

Figure 1: Schematic diagram	5
Figure 2: Pin connection diagram (top view)	5
Figure 3: Reverse B+ test circuit.....	7
Figure 4: Setpoint voltage vs. L terminal signal	7
Figure 5: Multiwatt 8 (pin 5GND) package outline	10

1 Schematic diagram and pin description

1.1 Schematic diagram

Figure 1: Schematic diagram

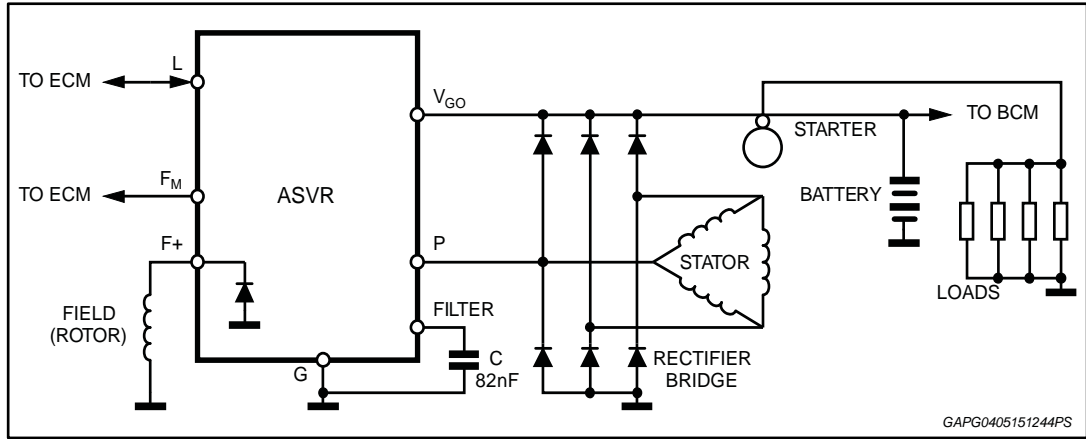

1.2 Pin description

Figure 2: Pin connection diagram (top view)

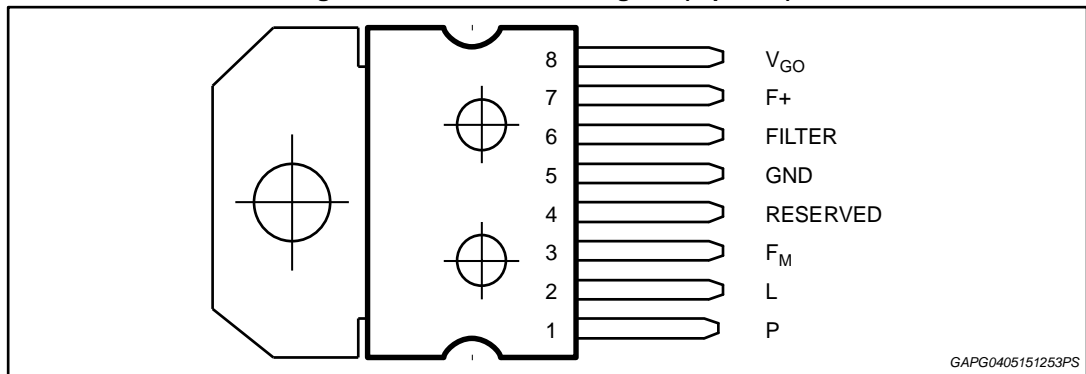

Table 2: Pin description

N°	Pin	Function
1	P	Phase sense input
2	L	Warning terminal output and ECM PWM input
3	F _M	Field monitor output
4	RESERVE D	Reserved
5	GND	Ground
6	FILTER	Regulation loop filter
7	F+	Field high side driver output
8	V _{GO}	Generator output sense and voltage supply to L9474N

2 Electrical specification

2.1 Absolute maximum ratings

Table 3: Absolute maximum ratings

Symbol	Parameter	Value	Unit
V _S	Transient supply voltage (load dump)	40	V
I _O	Output current capability	Internally limited	A
P _{tot}	Power dissipation (@T _j = 150 °C, I _{Field} = 6 A)	6	W
V _{REV}	Reverse voltage (see fig.1)	-2.5 to -6	V

2.2 Thermal data

Table 4: Thermal data

Symbol	Parameter	Value	Unit
T _j	Junction temperature	-40 to 150	°C
T _{stg}	Storage temperature	-50 to 150	°C
T _{sd}	Thermal shut down	175 ±15	°C
R _{th-j-case}	Thermal Resistance Junction-to-case	1.5	°C/W

2.3 Electrical characteristic

T_j-35 °C to +150 °C unless otherwise specified.

Table 5: Electrical characteristic

Symbol	Parameter	Test condition	Min.	Typ.	Max.	Unit
V _{OS}	Operating supply voltage	-	8	-	16 ⁽¹⁾	V
I _{SB}	Standby Current ⁽²⁾	V _{GO} = 12.6 V, T _{case} =-35 to +80 °C	-	-	400	µA
		V _{GO} = 12.6 V, 80 < T _{case} < +150 °C	-	-	1	mA
V _{SF}	Regulator Set-Point in Fault	PWM signal loss	13.6	13.8	14.0	V
V _{NB}	Generator output, no battery	No battery, I _{OUT} = 2 A to 50% max load	V _S -2	-	V _S +2	V
T _C	Thermal compensation	Driven by ECM	RVC or FLAT			V
V _{LR}	Load regulation	6500 grpm, 10% to 95% load	-	-	300	mV
V _{SR}	Speed regulation	15A load, 2,000 to 10,000 grpm	-	-	100	mV
V _{FON}	Output saturation voltage	I _F = 9 A, T _{case} ≤ 25 °C	-	-	750	mV
		I _F = 6 A, T _{case} > 25 °C	-	-	850	mV
I _{FLIM}	Field limit current	F shorted to GND, T _{case} ≤ 25 °C	9	-	-	A
		F shorted to GND, T _{case} = 150 °C	6	-	-	A
V _F	Field discharge rectifier	I _F = 6 A, T _{case} = 25 °C	-	-	1.85	V
I _R	Diode reverse current	V _R = 16 V	-	-	1	mA
f _{OSC}	Oscillation frequency	During LRC operation	340	400	460	Hz

Symbol	Parameter	Test condition	Min.	Typ.	Max.	Unit
MFDC	Minimum field duty-cycle	$V(V_{GO}) < V_{OV}^{(3)}$	-	6.25	-	%
R_{FM}	Impedance @ F_{Mpin}	Impedance between FM and F+	0.8	-	2.5	k Ω

Notes:

⁽¹⁾16 V is the maximum operating voltage.

⁽²⁾Standby current measured with L, FM open; F connected to GND; P open or tied to GND.

⁽³⁾When the voltage sensed at V_{GO} terminal is above V_{OV} the Minimum Field Duty-Cycle will be 0%.

Figure 3: Reverse B+ test circuit

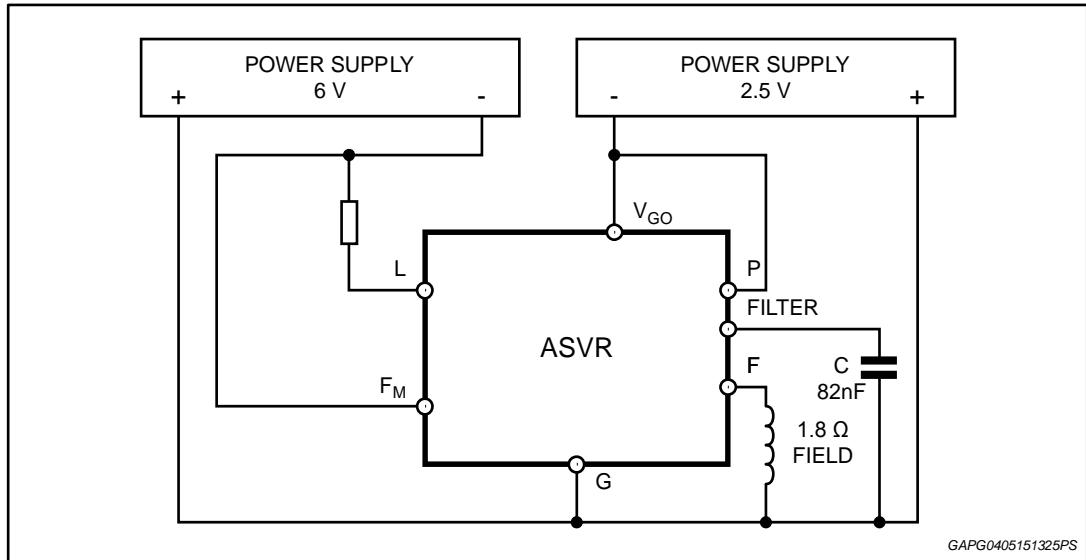
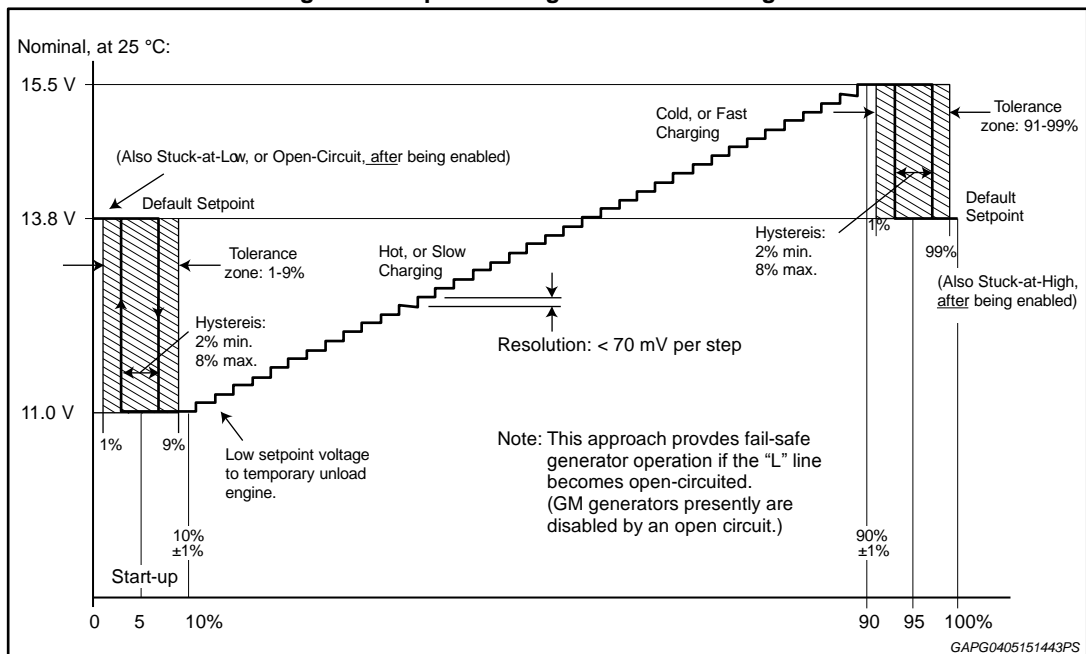

Figure 4: Setpoint voltage vs. L terminal signal



2.4 Diagnostic

T_j -35 °C to +150 °C unless otherwise specified.

Table 6: Diagnostic

Symbol	Parameter	Test condition	Min.	Typ.	Max.	Unit
V_{OV}	Overvoltage ⁽¹⁾	-	16.5	-	22	V
V_{LSAT}	L saturation voltage	$I_L = 50$ mA	-	-	1.35	V
T_{DELAY}	Fault indication delay time		0.935	1.1	1.265	s

Notes:

⁽¹⁾When the V_{GO} voltage overcomes this value the MFDC is deleted.

2.5 Fault

The following table lists the conditions that cause the fault driver to function L terminal now switching between 0 V and V_{LSAT} . To prevent L flicker, specific faults are required to be present for T_{DELAY} seconds before the fault driver is activated. This delay is indicated in the table.

Table 7: Fault driver to function list condition

Conditions	Delay
1. Key-on (RVC PWM signal acknowledgment)	No
2. Phase Voltage < $VP2$ AND V_{GO} < setpoint	Yes

2.6 Regulation features

Table 8: Regulation features

Symbol	Parameter	Test Condition	Min.	Typ.	Max.	Unit
V_{LON}	Lamp term turn on threshold ⁽¹⁾	$f_L = 128$ Hz $\pm 5\%$	0.65	0.9	1.15	V
I_{LON}	Lamp term turn on current	$V_L = 0.65$ V	0.3	-	1.5	mA
V_{P1}	Initiation of regulation detection phase voltage threshold ⁽²⁾	$I_P = 1$ mA (sinking current)	-	0.35	-	V
V_{P2}	Fault detection phase voltage threshold ⁽³⁾	-	7	8	9	V
I_P	Sinking current @ P terminal	$V_P = 1.5$ V	0.5	1	1.8	mA
f_{IFR}	Initiation of field regulation frequency	-	-	72	-	Hz
FSDF	Field Strobe Duty Factor	@ 'power up' with $f_{PHASE} < f_{IFR}$	-	12.5	-	%
LRC	Load response control rate ⁽⁴⁾	-	2.125	2.5	2.875	s
f_{LRC}	LRC transition frequency	LRC disabled above this value	263	310	357	Hz
Δgnd	Difference between ECM & alternator ground	-	-0.2	-	0.2	V

Notes:

⁽¹⁾A 128 Hz PWM signal applied to L input, higher than this threshold, will turn on the device.

⁽²⁾This threshold on the phase signal is used to detect the phase frequency, f_{IFR} , for the Initiation of field regulation.

⁽³⁾This threshold on the phase signal is used to sense the presence of the phase for fault detection purposes. Furthermore, to prevent the loss of phase signal, a 31.25% duty cycle is applied to field output when phase drops below V_{p2} and V_{GO} is above setpoint.

⁽⁴⁾This is the time duration the L9474N takes to ramp up from 0% to 100% duty cycle in response to an increased load on the generator. The LRC ratio is set 1:4 and the V_{reg} comparator status is latched at fundamental frequency rate.

3 Package information

In order to meet environmental requirements, ST offers these devices in different grades of ECOPACK® packages, depending on their level of environmental compliance. ECOPACK® specifications, grade definitions and product status are available at: www.st.com. ECOPACK® is an ST trademark.

3.1 Multiwatt 8 (pin 5 GND) package information

Figure 5: Multiwatt 8 (pin 5GND) package outline

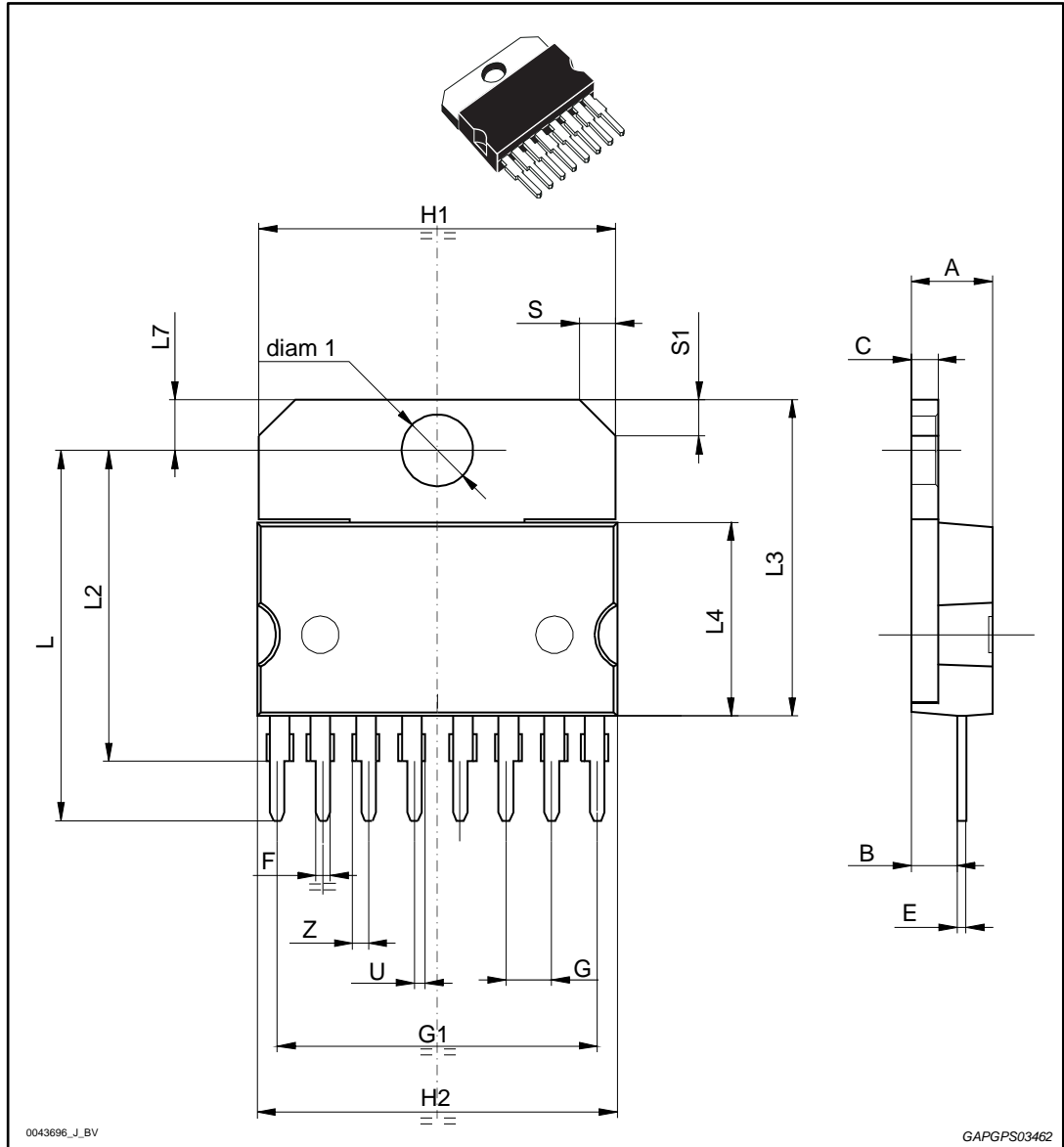

Table 9: Multiwatt 8 (pin 5GND) package mechanical drawing

Ref	Dimensions					
	Millimeters			Inches ⁽¹⁾		
	Min.	Typ.	Max.	Min.	Typ.	Max.
A	-	-	5	-	-	0.1969
B	-	-	2.65	-	-	0.1043
C	-	-	1.6	-	-	0.0630
E	0.49	-	0.55	0.0193	-	0.0217
F	0.78	-	0.85	0.0307	-	0.0335
G	2.40	2.54	2.68	0.0945	0.1000	0.1055
G1	17.64	17.78	17.92	0.6945	0.7000	0.7055
H1	19.6	-	-	0.7717	-	-
H2	-	-	20.2	-	-	0.7953
L	20.35		20.65	0.8012		0.8130
L2	17.05	17.20	17.35	0.6713	0.6772	0.6831
L3	17.25	17.5	17.75	0.6791	0.6890	0.6988
L4	10.3	10.7	10.9	0.4055	0.4213	0.4291
L7	2.65	-	2.9	0.1043	-	0.1142
S	1.9	-	2.6	0.0748	-	0.1024
S1	1.9	-	2.6	0.0748	-	0.1024
U	0.40	-	0.55	0.0157	-	0.0217
Z	0.70	-	0.85	0.0276	-	0.0335
diam1	3.65	-	3.85	0.1437	-	0.1516

Notes:

⁽¹⁾Values in inches are converted from mm and rounded to 4 decimal digits.

4 Revision history

Table 10: Document revision history

Date	Revision	Changes
05-May-2015	1	Initial release.

IMPORTANT NOTICE – PLEASE READ CAREFULLY

STMicroelectronics NV and its subsidiaries ("ST") reserve the right to make changes, corrections, enhancements, modifications, and improvements to ST products and/or to this document at any time without notice. Purchasers should obtain the latest relevant information on ST products before placing orders. ST products are sold pursuant to ST's terms and conditions of sale in place at the time of order acknowledgement.

Purchasers are solely responsible for the choice, selection, and use of ST products and ST assumes no liability for application assistance or the design of Purchasers' products.

No license, express or implied, to any intellectual property right is granted by ST herein.

Resale of ST products with provisions different from the information set forth herein shall void any warranty granted by ST for such product.

ST and the ST logo are trademarks of ST. All other product or service names are the property of their respective owners.

Information in this document supersedes and replaces information previously supplied in any prior versions of this document.

© 2015 STMicroelectronics – All rights reserved

X-ON Electronics

Largest Supplier of Electrical and Electronic Components

Click to view similar products for [Linear Voltage Regulators](#) category:

Click to view products by [STMicroelectronics](#) manufacturer:

Other Similar products are found below :

[LV56831P-E](#) [LV5684PVD-XH](#) [MCDTSA6-2R](#) [L7815ACV-DG](#) [LV56801P-E](#) [TCR3DF13,LM\(CT](#) [TCR3DF39,LM\(CT](#) [TLE42794G](#)
[L78L05CZ/1SX](#) [L78LR05DL-MA-E](#) [LM317T](#) [636416C](#) [714954EB](#) [LV5680P-E](#) [L78M15CV-DG](#) [L79M05T-E](#) [TLS202A1MBVHTSA1](#)
[L78LR05D-MA-E](#) [NCV317MBTG](#) [NTE7227](#) [NCV78M09BDTRKG](#) [LV5680NPVC-XH](#) [LT1054CN8](#) [ME6208A50M3G](#) [SL7533-8](#)
[ME6231A50M3G](#) [ME6231A50PG](#) [ME6231C50M5G](#) [AMS1117S-3.3](#) [AMS1117-5.0](#) [AMS1117S-5.0](#) [AMS1117-3.3](#) [MD5118](#) [MD5121](#)
[MD5127](#) [MD5128](#) [MD5130](#) [MD5144](#) [MD5150](#) [MD5115](#) [MD5125](#) [MD5133](#) [MD5136](#) [MD5140](#) [MD5110](#) [MD52E18WB6](#) [MD52E33WB6](#)
[MD52E15QA3](#) [MD52E21QA3](#) [MD52E25QA3](#)