

All silicon automotive voltage regulator

Datasheet - production data

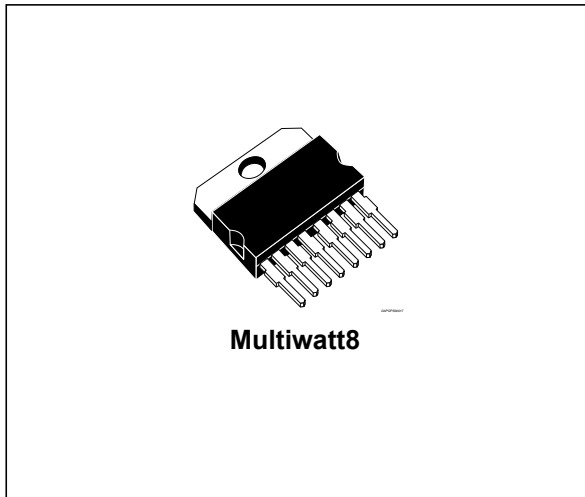

- Field driver short circuit protection
- RVC interface
- Overvoltage protection
- Complex diagnostics
- Load response control
 - LRC rate 2.5 s (L9914A, L9914C)
 - LRC rate 5.0 s (L9914B)

Description

The L9914 is a monolithic multifunction generator voltage regulator intended for use in automotive applications.

This device regulates the output of an automotive generator by controlling the field winding current by means of a variable frequency PWM high side driver.

The setpoint voltage reference is selected by the engine control unit (ECU) via RVC protocol.

Features

- AEC-Q100 qualified
- High side field driver
- Thermal protection



Table 1. Device summary

Order code	Temp range, °C	Package	Packing
L9914A	$T_j = -40$ to $+150$	Multiwatt8	Tube
L9914B	$T_j = -40$ to $+150$	Multiwatt8	Tube
L9914C	$T_j = -40$ to $+150$	Multiwatt8	Tube

Contents

- 1 Schematic diagram and pin description 5**
 - 1.1 Schematic diagram 5
 - 1.2 Pin description 5

- 2 Electrical specifications 6**
 - 2.1 Absolute maximum ratings 6
 - 2.2 Absolute maximum ratings and operative range by pin 6
 - 2.3 Thermal data 6
 - 2.4 Electrical characteristics 7
 - 2.5 Diagnostic 8
 - 2.5.1 Fault 8
 - 2.5.2 Regulation feature 9

- 3 Package information 10**
 - 3.1 Multiwatt 8 (pin 5 GND) package information 10

- 4 Revision history 12**

List of tables

Table 1.	Device summary	1
Table 2.	Pin description	5
Table 3.	Absolute maximum ratings	6
Table 4.	Absolute maximum ratings and operative range by pin	6
Table 5.	Thermal data	6
Table 6.	Electrical characteristics	7
Table 7.	Diagnostic	8
Table 8.	Fault	8
Table 9.	Regulation feature characteristics	9
Table 10.	Multiwatt 8 (pin 5GND) package mechanical drawing	11
Table 11.	Document revision history	12

List of figures

Figure 1.	Schematic diagram	5
Figure 2.	Pin connection (top view)	5
Figure 3.	Reverse B+ test circuit	7
Figure 4.	Setpoint voltage vs. L terminal signal	8
Figure 5.	Multiwatt 8 (pin 5GND) package outline	10

1 Schematic diagram and pin description

1.1 Schematic diagram

Figure 1. Schematic diagram

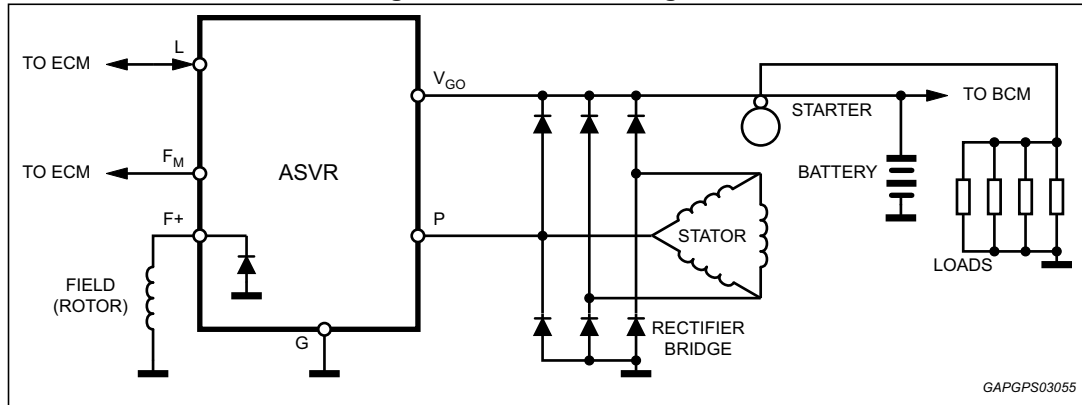

GAPGPS03055

1.2 Pin description

Figure 2. Pin connection (top view)

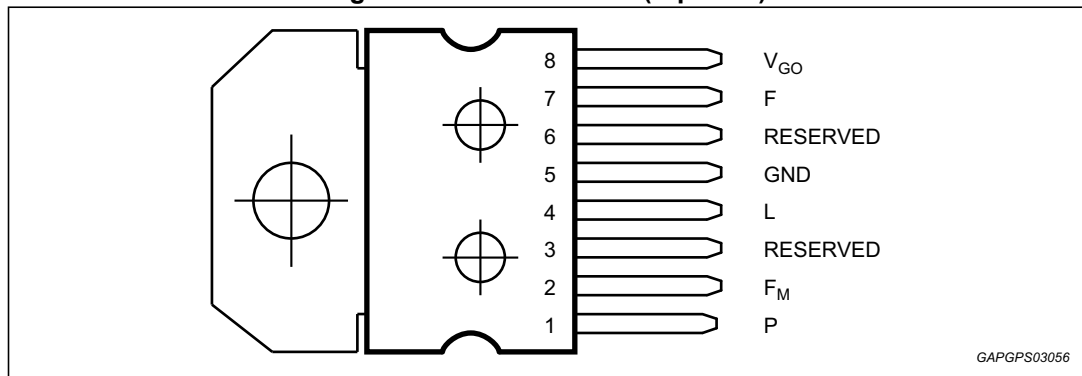

GAPGPS03056

Table 2. Pin description

N°	Pin	Function
1	P	Phase sense input
2	F _M	Field monitor output
3	RESERVED	Reserved
4	L	Warning terminal output and ECM PWM input
5	GND	Ground
6	RESERVED	Reserved
7	F	Field high side driver output
8	V _{Go}	Generator output sense and voltage supply to L9914

2 Electrical specifications

2.1 Absolute maximum ratings

Table 3. Absolute maximum ratings

Symbol	Parameter	Value	Unit
V_S	Transient supply voltage (load dump)	40	V
I_O	Output current capability	Internally limited	A
P_{tot}	Power dissipation (@ $T_j = 150^\circ\text{C}$, $I_{Field} = 6\text{ A}$)	6	W
V_{REV}	Reverse voltage (see <i>Figure 1.</i>)	-2.5 to -6	V

2.2 Absolute maximum ratings and operative range by pin

Table 4. Absolute maximum ratings and operative range by pin

Pin #	Name	Absolute maximum rating		Operative range		Unit
		Min.	Max.	Min.	Max.	
1	P	-5	VGO+3V	-1.5	20	V
2	FM	-1.5	50	-1.5	18	V
3	RESERVED	-0.3	7	must be connect to GND		V
4	L	-0.3	50	-0.3	18	V
5	GND	-	-	-	-	-
6	RESERVED	-0.3	7	must be connect to GND		V
7	F	-1.5	VGO	-1.5	VGO	V
8	VGO	-2.5	50	8	18	V

2.3 Thermal data

Table 5. Thermal data

Symbol	Parameter	Value	Unit
T_j	Junction temperature	-40 to 150	$^\circ\text{C}$
T_{stg}	Storage temperature	-50 to 150	$^\circ\text{C}$
T_{sd}	Thermal shut down	175 \pm 15	$^\circ\text{C}$
$R_{th\ j-case}$	Thermal resistance junction to case	1.5	$^\circ\text{C/W}$

2.4 Electrical characteristics

T_j -35 °C to +150 °C unless otherwise specified.

Table 6. Electrical characteristics

Symbol	Parameter	Test conditions	Min.	Typ.	Max.	Unit
V_{OS}	Operating supply voltage	-	8	-	16 ⁽¹⁾	V
I_{SB}	Standby current ⁽²⁾	$V_{GO} = 12.6$ V, $T_{case} -35$ to $+80$ °C	-	-	400	μ A
		$V_{GO} = 12.6$ V, $80 < T_{case} < +150$ °C	-	-	1	mA
V_{SF}	Regulator set-point in fault	PWM signal loss	-	13.8	-	V
V_{NB}	Generator output, no battery	No battery, $I_{OUT} = 2$ A to 50 % max load	$V_S^{(3)}-2$	-	V_S+2	V
T_C	Thermal compensation	Driven by ECM	RVC or FLAT			V
V_{LR}	Load regulation - L9914A,C	6500 grpm, 10 % to 95 % load	-	-	300	mV
	Load regulation - L9914B		-	-	400	
V_{SR}	Speed regulation	15 A load, 2,000 to 10,000 grpm	-	-	100	mV
V_{FON}	Output saturation voltage	$I_F = 9$ A, $T_{case} \leq 25$ °C	-	-	750	mV
V_{FON}	Output saturation voltage	$I_F = 6$ A, $T_{case} > 25$ °C	-	-	850	mV
I_{FLIM}	Field limit current	F shorted to GND, $T_{case} \leq 25$ °C	9	-	-	A
		F shorted to GND, $T_{case} = 150$ °C	6	-	-	A
V_F	Field discharge rectifier	$I_F = 6$ A, $T_{case} = 25$ °C	-	-	1.85	V
I_R	Diode reverse current	$V_R = 16$ V	-	-	1	mA
f_{OSC}	Oscillation frequency	During LRC operation	340	400	460	Hz
MFDC	Minimum field duty-cycle	$V(V_{GO}) < V_{OV}$ ⁽⁴⁾	-	6.25	-	%
R_{FM}	Impedance @ F_M pin	Impedance between FM and F+	5	-	15	K Ω

- 16 V is the maximum operating voltage.
- Standby current measured with L, FM open; F connected to GND; P open or tied to GND.
- $V_S = V_{set}$ point (with or without protocol).
- When the voltage sensed at V_{GO} terminal is above V_{OV} the minimum field duty-cycle will be 0%.

Figure 3. Reverse B+ test circuit

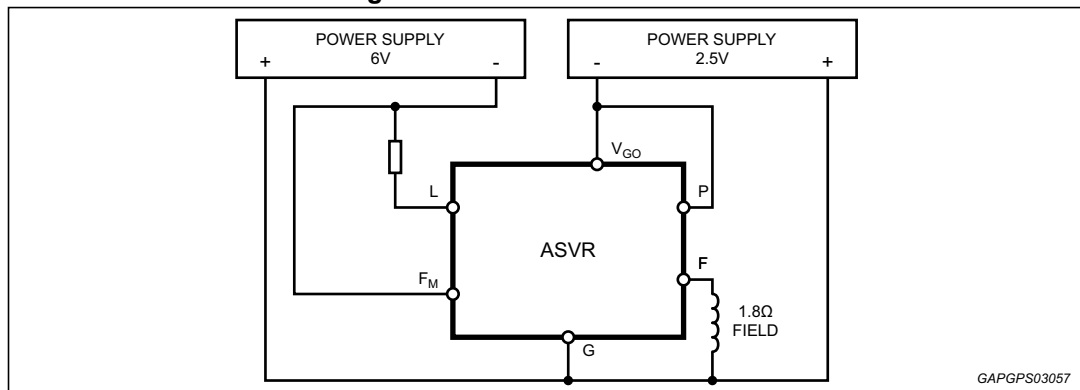
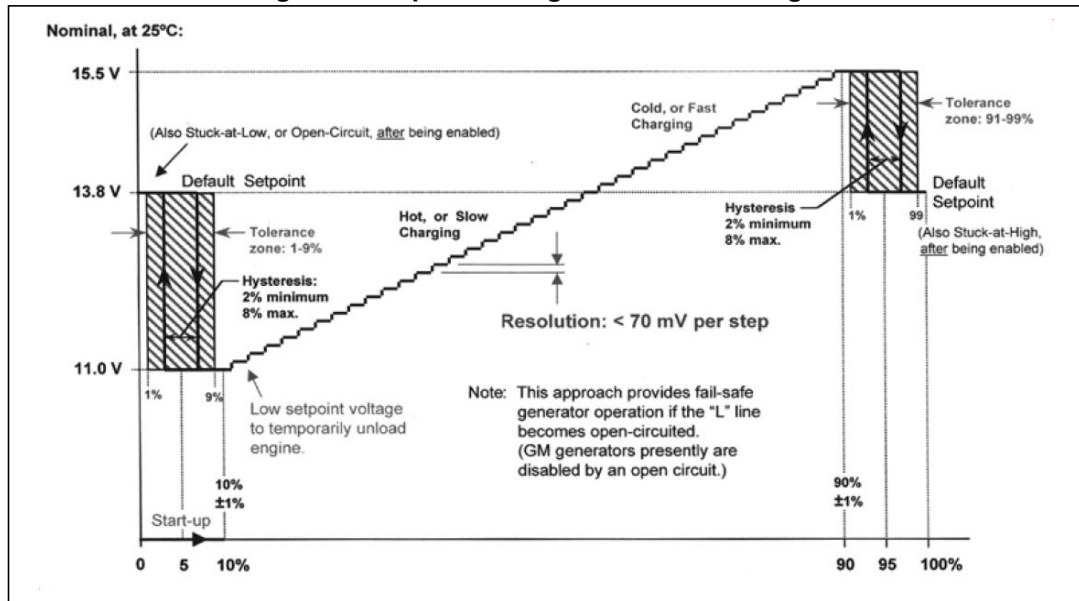

Figure 4. Setpoint voltage vs. L terminal signal



2.5 Diagnostic

T_j -35 °C to +150 °C unless otherwise specified.

Table 7. Diagnostic

Symbol	Parameter	Test conditions	Min.	Typ.	Max.	Unit
V_{OV}	Overvoltage ⁽¹⁾	-	16.5	-	22	V
T_{DELAY}	Fault indication delay time	-	0.935	1.1	1.265	s

1. When the V_{GO} voltage overcomes this value the MFDC is cancelled.

2.5.1 Fault

The following table lists the conditions that cause the fault driver to function (L terminal now switching between 0 V and V_{LSAT}). To prevent L flicker, specific faults are required to be present for T_{DELAY} seconds before the fault driver is activated. This delay is indicated in the following table.

Table 8. Fault

Conditions	Delay
1. Key-on (RVC PWM signal acknowledgement)	No
2. Phase voltage < V_{P2} and V_{GO} < setpoint	Yes

2.5.2 Regulation feature

Table 9. Regulation feature characteristics

Symbol	Parameter	Test conditions	Min.	Typ.	Max.	Unit
V_{LON}	Lamp term turn on ⁽¹⁾ threshold	$f_L = 128 \text{ Hz} \pm 5 \%$	0.65	0.9	1.15	V
I_{LON}		$V_L = 0.65 \text{ V}$	0.3	-	1.5	mA
V_{P1}	Initiation of regulation detection phase voltage threshold ⁽²⁾	$I_P = 1 \text{ mA}$ (sinking current)	-	0.4	-	V
V_{P2}	Fault detection phase voltage threshold ⁽³⁾	-	7	8	9	V
I_P	Sinking current @ P terminal	$V_P = 1.5 \text{ V}$	0.5	1	1.8	mA
f_{IFR}	Initiation of field regulation frequency	for L9914A,B	61	72	83	Hz
		for L9914C	103	122	141	Hz
FSDF	Field strobe duty factor	@ "power up" with $f_{PHASE} < f_{IFR}$ for L9914B	-	18.75	-	%
		@ "power up" with $f_{PHASE} < f_{IFR}$ for L9914A, L9914C	-	13.5	-	%
LRC	Load response control rate ⁽⁴⁾	for L9914A, L9914C for L9914B	2.125 4.25	2.5 5.0	2.875 5.75	s
f_{LRC}	LRC transition frequency	LRC disabled above this value for L9914A,B	263	310	357	Hz
		LRC disabled above this value for L9914C	297	350	403	Hz
Δgnd	Difference between ECM & alternator ground	-	-0.2	-	0.2	V
V_{OV}	Overvoltage	-	16.5	-	22	V
V_{LSAT}	L saturation voltage	$I_L = 10 \text{ mA}$	-	-	1.55	V
T_{DELAY}	Fault indication delay time	-	0.935	1.1	1.265	s

1. A 128 Hz PWM signal applied to L input, higher than this threshold, will turn on the device.
2. This threshold on the phase signal is used to detect the phase frequency, f_{IFR} , for the Initiation of field regulation.
3. This threshold on the phase signal is used to sense the presence of the phase for fault detection purposes. Furthermore, to prevent the loss of phase signal, a 31.25% duty cycle is applied to field output when phase drops below V_{P2} and V_{GO} is above setpoint.
4. This is the time duration the L9914 takes to ramp up from 0% to 100% duty cycle in response to an increased load on the generator. The LRC ratio is set 1:4 and the V_{REG} comparator status is latched at fundamental frequency rate.

3 Package information

In order to meet environmental requirements, ST offers these devices in different grades of ECOPACK[®] packages, depending on their level of environmental compliance. ECOPACK[®] specifications, grade definitions and product status are available at: www.st.com.

ECOPACK[®] is an ST trademark.

3.1 Multiwatt 8 (pin 5 GND) package information

Figure 5. Multiwatt 8 (pin 5 GND) package outline

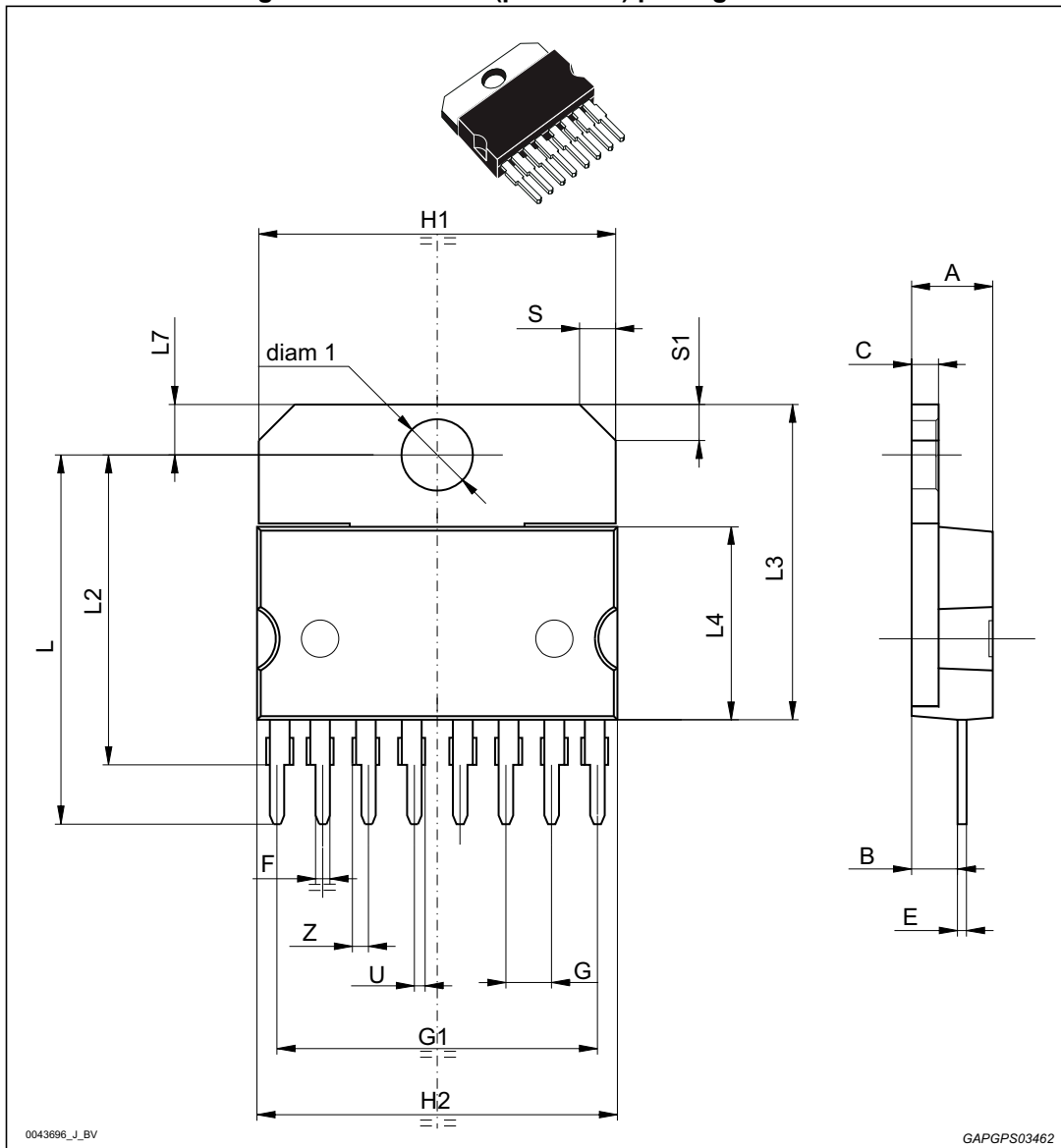

Table 10. Multiwatt 8 (pin 5GND) package mechanical drawing

Ref	Dimensions					
	Millimeters			Inches ⁽¹⁾		
	Min.	Typ.	Max.	Min.	Typ.	Max.
A	-	-	5	-	-	0.1969
B	-	-	2.65	-	-	0.1043
C	-	-	1.6	-	-	0.0630
E	0.49	-	0.55	0.0193	-	0.0217
F	0.78	-	0.85	0.0307	-	0.0335
G	2.40	2.54	2.68	0.0945	0.1000	0.1055
G1	17.64	17.78	17.92	0.6945	0.7000	0.7055
H1	19.6	-	-	0.7717	-	-
H2	-	-	20.2	-	-	0.7953
L	20.35		20.65	0.8012		0.8130
L2	17.05	17.20	17.35	0.6713	0.6772	0.6831
L3	17.25	17.5	17.75	0.6791	0.6890	0.6988
L4	10.3	10.7	10.9	0.4055	0.4213	0.4291
L7	2.65	-	2.9	0.1043	-	0.1142
S	1.9	-	2.6	0.0748	-	0.1024
S1	1.9	-	2.6	0.0748	-	0.1024
U	0.40	-	0.55	0.0157	-	0.0217
Z	0.70	-	0.85	0.0276	-	0.0335
diam1	3.65	-	3.85	0.1437	-	0.1516

1. Values in inches are converted from mm and rounded to 4 decimal digits.

4 Revision history

Table 11. Document revision history

Date	Revision	Changes
22-May-2006	1	Initial release.
20-Nov-2008	2	Document status promoted from preliminary data to production.
19-Sep-2013	3	Updated disclaimer.
09-Apr-2014	4	Updated: <i>Features and Description on page 1;</i> <i>Table 1: Device summary on page 1;</i> <i>Table 6: Electrical characteristics on page 7;</i> <i>Table 9: Regulation feature characteristics on page 9.</i>
04-Sep-2014	5	Added <i>Table 4: Absolute maximum ratings and operative range by pin on page 6.</i>
16-Apr-2018	6	Added in cover page “automotive” in the title and a new feature “AEC-Q100 qualified”. Updated in <i>Table 9 on page 9</i> the “Field strobe duty factor” parameter. Reformatted <i>Section 3: Package information</i> , no content change.

IMPORTANT NOTICE – PLEASE READ CAREFULLY

STMicroelectronics NV and its subsidiaries ("ST") reserve the right to make changes, corrections, enhancements, modifications, and improvements to ST products and/or to this document at any time without notice. Purchasers should obtain the latest relevant information on ST products before placing orders. ST products are sold pursuant to ST's terms and conditions of sale in place at the time of order acknowledgement.

Purchasers are solely responsible for the choice, selection, and use of ST products and ST assumes no liability for application assistance or the design of Purchasers' products.

No license, express or implied, to any intellectual property right is granted by ST herein.

Resale of ST products with provisions different from the information set forth herein shall void any warranty granted by ST for such product.

ST and the ST logo are trademarks of ST. All other product or service names are the property of their respective owners.

Information in this document supersedes and replaces information previously supplied in any prior versions of this document.

© 2018 STMicroelectronics – All rights reserved

X-ON Electronics

Largest Supplier of Electrical and Electronic Components

Click to view similar products for [Power Management Specialized category](#):

Click to view products by [STMicroelectronics manufacturer](#):

Other Similar products are found below :

[LV5685PV-XH](#) [LV5686PVC-XH](#) [NCP51400MNTXG](#) [L5956](#) [SLG7NT4081VTR](#) [PD-POE EXTENDER](#) [MC34FS6408NAE](#)

[KIT33908LAEEVB](#) [L5959](#) [PM6764TR](#) [MAX1856EUBT](#) [LV56841PVD-XH](#) [MIC5167YML-TR](#) [STLUX383A](#) [PM6766TR](#)

[LP2996AMRENOPB](#) [STM6600BQ24DM6F](#) [MIC5166YML-TR](#) [FAN4149M6X](#) [FAN41501SX](#) [AD8436ACPZ-R7](#) [BD3539NUX-TR](#)

[BA5810FP-E2](#) [BD3925FP-CE2](#) [BD7602GUL-E2](#) [BD8163EFV-E2](#) [BD83854MUV-E2](#) [BD95820N-LB](#) [BD95850F-LBE2](#) [MAX17811GTL+](#)

[MAX17113ETL+](#) [NCP51190MNTAG](#) [L6759DTR](#) [L6788ATR](#) [L9911P](#) [AD8436JCPZ-R7](#) [L9911F](#) [L9911V](#) [ATPL230A-AKU-Y](#) [LP2995M](#)

[MAX20751EKX+](#) [MAX17021GTL+](#) [MAX20751EKX+T](#) [HF81GS](#) [TL7726CPG4](#) [PS5171](#) [AS8650B-ZQFM-01](#) [AD536AKHZ](#)

[AD5560JBCZ](#) [AD636JDZ](#)