

Features

- Bidirectional device: LBP01-0810B
- Unidirectional device: LBP01-0803SC5
- RoHS compliant

Benefits

- Keep LED strings on in case of LED open mode failure
- Reduced maintenance cost
- Increase lifetime of the lighting system

Complies with the following standards:

- IEC61000-4-2 level 4
 - ±15 kV (air discharge)
 - ±8 kV (contact discharge)
- IEC 61000-4-5
 - ±1kV / 24 A

Applications

This device shunts failed LEDs in applications where LED strings can not be turned-off for safety reason due to a LED failure. Main applications are:

- Automotive headlights
- Traffic lights
- Aircraft runaway lights
- Emergency lighting systems
- Display panel backlighting
- Street lighting

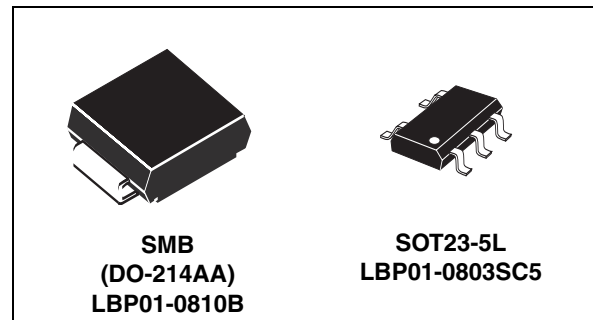
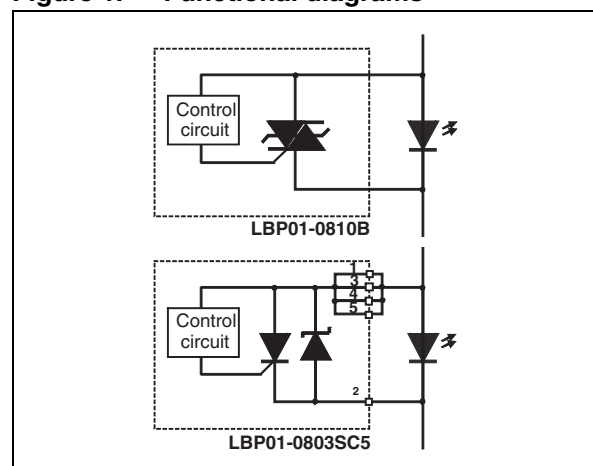

Figure 1. Functional diagrams



Description

The LBP01 series are bypass switches to be connected in parallel with 1 or 2 LEDs. In case of LED failure, this allows the current to flow through the other LEDs.

It also provides an overvoltage protection against surges defined in IEC 61000-4-2 and IEC 61000-4-5

Their robust dice also protect LEDs against surge.

These devices are compatible with LEDs up to 1 A.

LBP01 are packaged either in SMB or SOT23-5L

1 Characteristics

Table 1. Absolute maximum ratings ($T_{amb} = 25\text{ °C}$)

Symbol	Parameter		Value	Unit
V_{PP}	Peak pulse voltage	IEC 61000-4-2 contact discharge	30	kV
I_{PP}	Repetitive peak pulse current (8/20 μ s)		24	A
I_F	On-state DC current	SOT23-5L	0.35	A
		SMB	1	A
T_j	Operating junction temperature range		-55 to 150	$^{\circ}\text{C}$
T_{stg}	Storage temperature range		-65 to 150	$^{\circ}\text{C}$
T_L	Maximum lead temperature for soldering during 10 s		260	$^{\circ}\text{C}$

Table 2. Electrical characteristics ($T_{amb} = 25\text{ °C}$)

Symbol	Test conditions		Min.	Typ.	Max.	Unit
I_{RM}	$V_{RM} = 3\text{ V}$				100	nA
V_{BO}			8		15	V
I_H		SOT23-5L			200	mA
		SMB			200	
V_{on}	$I_{on} = 0.35\text{ A}^{(1)}$	SOT23-5L			2	V
	$I_{on} = 0.35\text{ A}$	SMB			1.3	V
	$I_{on} = 1\text{ A}$	SMB			1.5	V
dV/dt			300			V/ μ s
$R_{th(j-a)}$	On recommended pad layout with copper area of 1 cm^2	SOT23-5L		140		$^{\circ}\text{C/W}$
		SMB		100		$^{\circ}\text{C/W}$

1. Measured between pin 1, 3, 4, or 5 and pin 2

Figure 2. Thermal resistance, junction to ambient, versus copper area under each lead (SMB)

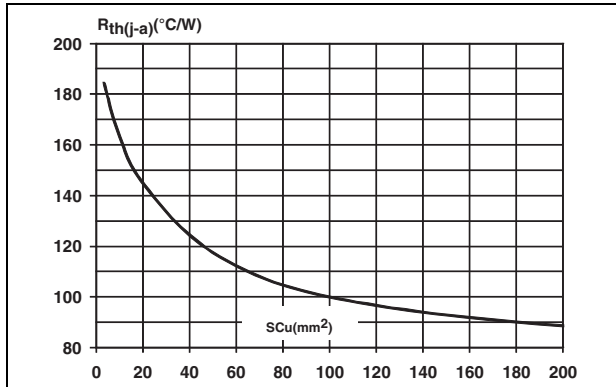
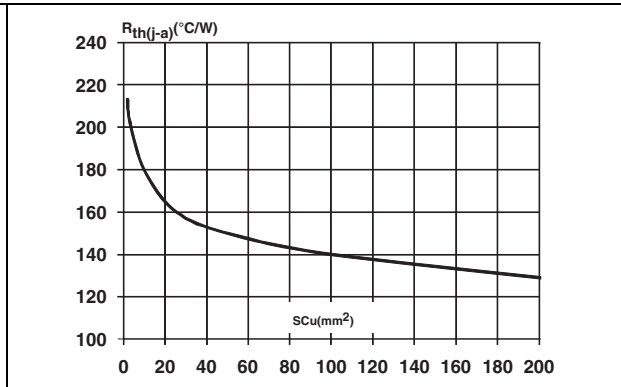
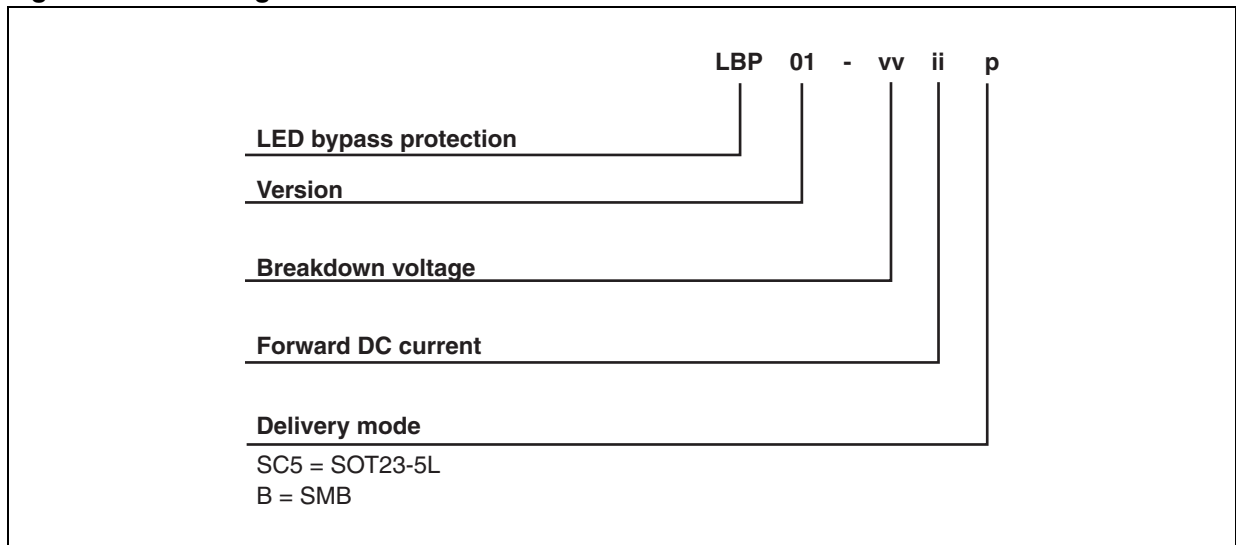

Figure 3. Thermal resistance, junction to ambient, versus copper area under each lead (SOT23-5L)



2 Ordering information scheme

Figure 4. Ordering information scheme



3 Package information

- Epoxy meets UL94, V0
- Lead-free package

In order to meet environmental requirements, ST offers these devices in different grades of ECOPACK® packages, depending on their level of environmental compliance. ECOPACK® specifications, grade definitions and product status are available at: www.st.com. ECOPACK® is an ST trademark.

Table 3. SMB dimensions

Ref.	Dimensions			
	Millimeters		Inches	
	Min.	Max.	Min.	Max.
A1	1.90	2.45	0.075	0.096
A2	0.05	0.20	0.002	0.008
b	1.95	2.20	0.077	0.087
c	0.15	0.40	0.006	0.016
D	3.30	3.95	0.130	0.156
E	5.10	5.60	0.201	0.220
E1	4.05	4.60	0.159	0.181
L	0.75	1.50	0.030	0.059

Figure 5. Footprint, dimensions in mm **Figure 6. Marking⁽¹⁾ (inches)**

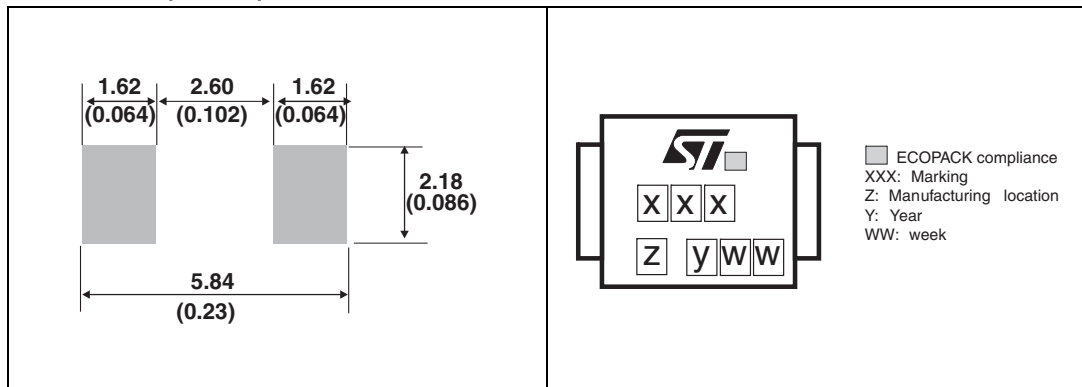

1. Product marking may be rotated by 90° for assembly plant differentiation. In no case should this product marking be used to orient the component for its placement on a PCB. Only pin 1 mark is to be used for this purpose.

Table 4. SOT23-5L dimensions

Ref.	Dimensions					
	Millimeters			Inches		
	Min.	Typ.	Max.	Min.	Typ.	Max.
A	0.90		1.45	0.035		0.057
A1	0		0.10	0		0.004
A2	0.90		1.30	0.035		0.051
b	0.35		0.50	0.014		0.020
c	0.09		0.20	0.004		0.008
D	2.80		3.05	0.11		0.118
E	1.50		1.75	0.059		0.069
e		0.95			0.037	
H	2.60		3.00	0.102		0.118
L	0.10		0.60	0.004		0.024
M	0°		10°	0°		10°

Figure 7. Footprint, dimensions in mm **Figure 8. Marking (inches)**

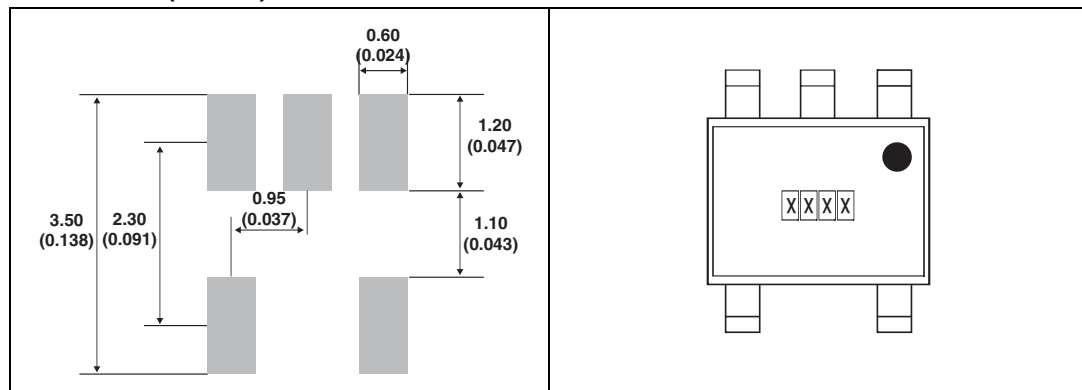

4 Recommendations on PCB assembly

4.1 PCB design

1. To control the solder paste amount, the closed via is recommended instead of open vias.
2. The position of tracks and open vias in the solder area should be well balanced. The symmetrical layout is recommended, in case any tilt phenomena caused by asymmetrical solder paste amount due to the solder flow away.

Figure 9. Printed circuit board layout

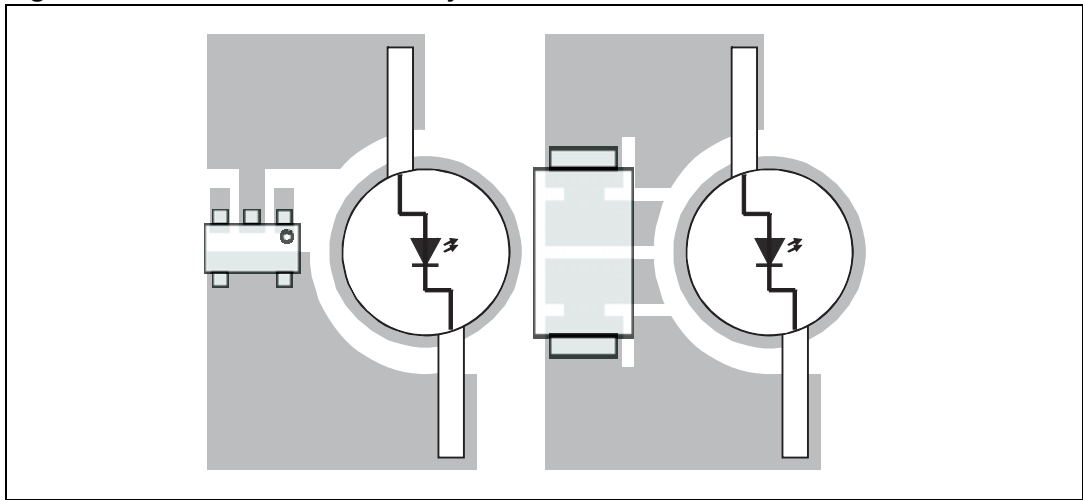

4.2 Reflow profile

Figure 10. ST ECOPACK[®] recommended soldering reflow profile for PCB mounting

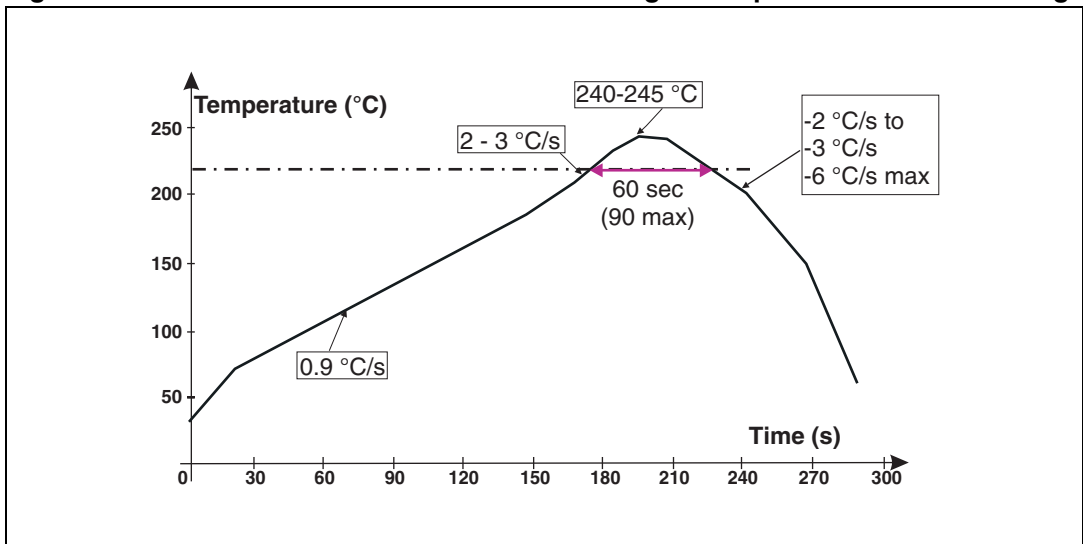

Note: Minimize air convection currents in the reflow oven to avoid component movement.

5 Ordering information

Table 5. Ordering information

Order code	Marking	Package	Weight	Base qty	Delivery mode
LBP01-0803SC5	XT08	SOT23-5L	16 mg	3000	Tape and reel
LBP01-0810B	L08 ⁽¹⁾	SMB	0.11 g	2500	Tape and reel

1. The marking can be rotated by 90° to differentiate assembly location.

6 Revision history

Table 6. Document revision history

Date	Revision	Changes
20-Mar-2012	1	Initial release.

Please Read Carefully:

Information in this document is provided solely in connection with ST products. STMicroelectronics NV and its subsidiaries ("ST") reserve the right to make changes, corrections, modifications or improvements, to this document, and the products and services described herein at any time, without notice.

All ST products are sold pursuant to ST's terms and conditions of sale.

Purchasers are solely responsible for the choice, selection and use of the ST products and services described herein, and ST assumes no liability whatsoever relating to the choice, selection or use of the ST products and services described herein.

No license, express or implied, by estoppel or otherwise, to any intellectual property rights is granted under this document. If any part of this document refers to any third party products or services it shall not be deemed a license grant by ST for the use of such third party products or services, or any intellectual property contained therein or considered as a warranty covering the use in any manner whatsoever of such third party products or services or any intellectual property contained therein.

UNLESS OTHERWISE SET FORTH IN ST'S TERMS AND CONDITIONS OF SALE ST DISCLAIMS ANY EXPRESS OR IMPLIED WARRANTY WITH RESPECT TO THE USE AND/OR SALE OF ST PRODUCTS INCLUDING WITHOUT LIMITATION IMPLIED WARRANTIES OF MERCHANTABILITY, FITNESS FOR A PARTICULAR PURPOSE (AND THEIR EQUIVALENTS UNDER THE LAWS OF ANY JURISDICTION), OR INFRINGEMENT OF ANY PATENT, COPYRIGHT OR OTHER INTELLECTUAL PROPERTY RIGHT.

UNLESS EXPRESSLY APPROVED IN WRITING BY TWO AUTHORIZED ST REPRESENTATIVES, ST PRODUCTS ARE NOT RECOMMENDED, AUTHORIZED OR WARRANTED FOR USE IN MILITARY, AIR CRAFT, SPACE, LIFE SAVING, OR LIFE SUSTAINING APPLICATIONS, NOR IN PRODUCTS OR SYSTEMS WHERE FAILURE OR MALFUNCTION MAY RESULT IN PERSONAL INJURY, DEATH, OR SEVERE PROPERTY OR ENVIRONMENTAL DAMAGE. ST PRODUCTS WHICH ARE NOT SPECIFIED AS "AUTOMOTIVE GRADE" MAY ONLY BE USED IN AUTOMOTIVE APPLICATIONS AT USER'S OWN RISK.

Resale of ST products with provisions different from the statements and/or technical features set forth in this document shall immediately void any warranty granted by ST for the ST product or service described herein and shall not create or extend in any manner whatsoever, any liability of ST.

ST and the ST logo are trademarks or registered trademarks of ST in various countries.

Information in this document supersedes and replaces all information previously supplied.

The ST logo is a registered trademark of STMicroelectronics. All other names are the property of their respective owners.

© 2012 STMicroelectronics - All rights reserved

STMicroelectronics group of companies

Australia - Belgium - Brazil - Canada - China - Czech Republic - Finland - France - Germany - Hong Kong - India - Israel - Italy - Japan - Malaysia - Malta - Morocco - Philippines - Singapore - Spain - Sweden - Switzerland - United Kingdom - United States of America

www.st.com

X-ON Electronics

Largest Supplier of Electrical and Electronic Components

Click to view similar products for [LED Protection Devices](#) category:

Click to view products by [STMicroelectronics](#) manufacturer:

Other Similar products are found below :

[HBL1025T1G](#) [SZHBL5006XV2T1G](#) [SZHBL5006HT1G](#) [LSP10277PX3373](#) [LSP3-20L-480](#) [LSP3-20-UNV](#) [LSP4-480](#) [LSP4-UNV](#)
[LSP05347P](#) [LSP05347PM](#) [LSP05480PM](#) [LSP05G240PX3316](#) [LSP05G240S](#) [LSP05G240SX3316](#) [LSP05G277P](#) [LSP05G277PX3316](#)
[LSP05G277PX3333](#) [LSP05G277S](#) [LSP05GI240S](#) [LSP05GI277P](#) [LSP05GI120S](#) [LSP05GI277PHX3333](#) [LSP05GI277S](#) [LSP10120P](#)
[LSP10120S](#) [LSP10277S](#) [LSP10347P](#) [LSP10480LLP](#) [LSP10480S](#) [LSP10480PX3334](#) [PLED9Q12](#) [PLED13Q12](#) [PLED13S](#) [PLED13UQ12](#)
[PLED180S](#) [PLED18Q12](#) [PLED18S](#) [PLED18UQ12](#) [PLED18US](#) [PLED230S](#) [PLED260S](#) [PLED310S](#) [PLED350S](#) [PLED6SW](#) [PLED6UQ12](#)
[PLED6US](#) [PLED9S](#) [PLED9UQ12](#) [SPD-10-320S](#) [SPD-10S-277S](#)