

## Programmable transient voltage suppressor for SLIC protection

Datasheet - production data

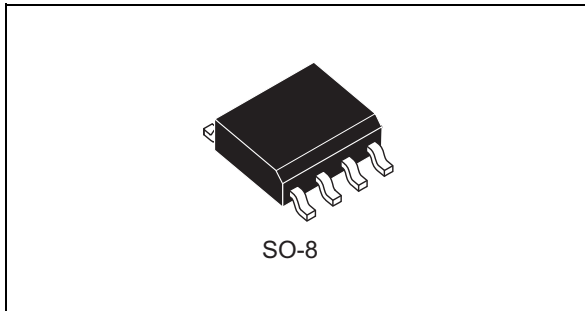
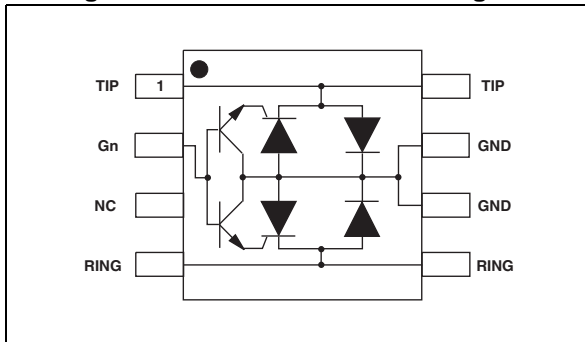

Figure 1. LCP1531 functional diagram



### Features

- Dual programmable transient suppressor
- Wide negative firing voltage range:  
 $V_{Gn} = -175 \text{ V max.}$
- Low dynamic switching voltages:  
 $V_{FP}$  and  $V_{DGL}$
- Low gate triggering current:  $I_{GT} = 5 \text{ mA max}$
- Peak pulse current:  $I_{PP} = 37.5 \text{ A (5/310 } \mu\text{s)}$
- Holding current:  $I_H = 150 \text{ mA min.}$
- Low space consuming package

### Benefits

- A Trisil™ is not subject to ageing and provides a fail-safe mode in short circuit for better protection.
- Trisils are used to help equipment to meet various standards such as YDT695, GR-1089 and ITU-T K20/21.
- Trisils are UL94 V0 resin approved and are UL497B approved [file: E136224]).

### Description

These devices are ideally suited to meet the protection requirement of VoIP SLICs located in next generation residential gateways. They can be used for protecting any ringing SLIC since they meet the protection standard requirements.

Positive overvoltages are clamped by 2 diodes. Negative surges are suppressed by 2 thyristors, their breakdown voltage being referenced to  $-V_{BAT}$  through the gate.

These components present a very low gate triggering current ( $I_{GT}$ ) to reduce the current consumption on printed circuit board during the firing phase.

TM: Trisil is a trademark of STMicroelectronics

# 1 Characteristics

**Table 1. Standards compliance**

Standard	Peak surge voltage (V)	Voltage waveform	Required peak current (A)	Current waveform	Minimum serial resistor to meet standard ( $\Omega$ )
GR-1089 Core First level	2500	2/10 $\mu$ s	500	2/10 $\mu$ s	20
	1000	10/1000 $\mu$ s	100	10/1000 $\mu$ s	30
GR-1089 Core Second level	5000	2/10 $\mu$ s	500	2/10 $\mu$ s	40
GR-1089 Core Intra-building	1500	2/10 $\mu$ s	100	2/10 $\mu$ s	0
ITU-T-K20/K21	6000	10/700 $\mu$ s	150	5/310 $\mu$ s	120
	1500		37.5		0
ITU-T-K20 (IEC 61000-4-2)	8000	1/60 ns	ESD contact discharge		0
	15000		ESD air discharge		0
IEC 61000-4-5	4000	10/700 $\mu$ s	100	5/310 $\mu$ s	67
	4000	1.2/50 $\mu$ s	100	8/20 $\mu$ s	22
TIA-968-A, lightning surge type A	1500	10/160 $\mu$ s	200	10/160 $\mu$ s	26
	800	10/560 $\mu$ s	100	10/560 $\mu$ s	17
TIA-968-A, lightning surge type B	1500	9/720 $\mu$ s	37.5	5/320 $\mu$ s	0

**Table 2. Thermal resistance**

Symbol	Parameter	Value	Unit
$R_{th(j-a)}$	Junction to ambient	120	$^{\circ}\text{C}/\text{W}$

**Table 3. Absolute ratings ( $T_{amb} = 25\text{ }^{\circ}\text{C}$ , unless otherwise specified)**

Symbol	Parameter	Value	Unit
$I_{PP}$	Peak pulse current	10/1000 $\mu\text{s}$	25
		8/20 $\mu\text{s}$	65
		10/560 $\mu\text{s}$	32
		5/310 $\mu\text{s}$	37.5
		10/160 $\mu\text{s}$	45
		1/20 $\mu\text{s}$	60
		2/10 $\mu\text{s}$	100
$I_{TSM}$	Non-repetitive surge peak on-state current (50 Hz sinusoidal)	t = 20 ms	16
		t = 200 ms	9
		t = 1 s	6
$I_{GSM}$	Maximum gate current (50 Hz sinusoidal)	t = 10 ms	2
$V_{Gn}$	Negative battery voltage range	-175	V
$T_{stg}$	Storage temperature range	-55 to +150	$^{\circ}\text{C}$
$T_j$	Operating junction temperature range	-40 to +150	
$T_L$	Maximum lead temperature for soldering during 10 s.	260	$^{\circ}\text{C}$

**Figure 2. Electrical characteristics (definitions)**

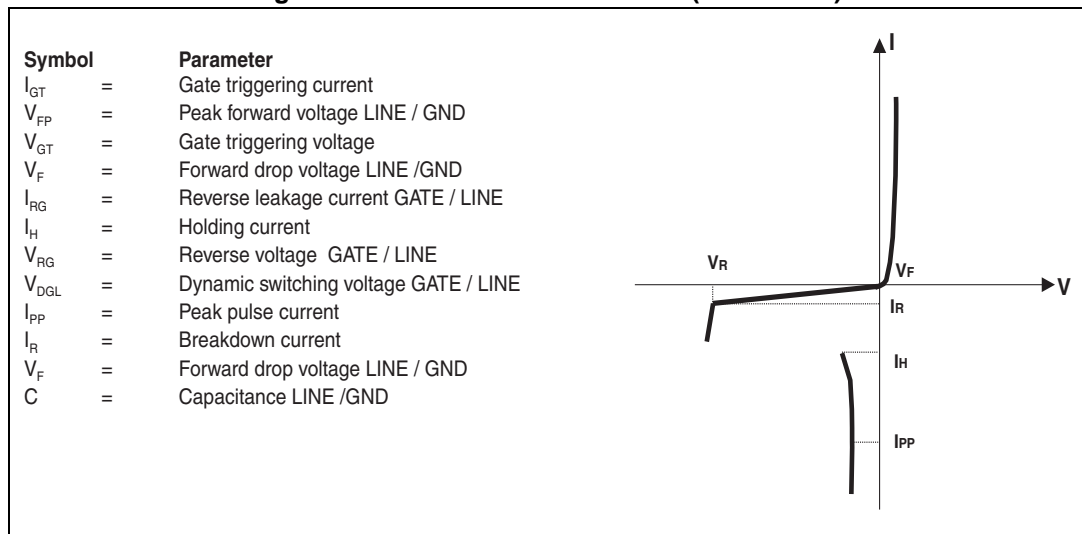

**Figure 3. Pulse waveform**

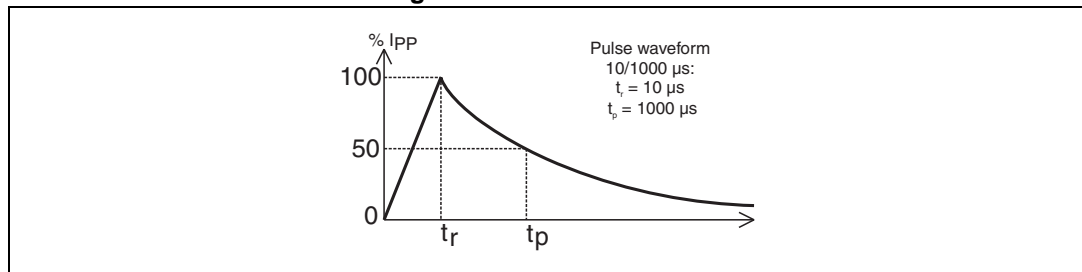

**Table 4. Parameters related to the diode LINE / GND (T<sub>amb</sub> = 25 °C)**

Symbol	Test conditions		Max.	Unit
V <sub>F</sub>	I <sub>F</sub> = 5 A	t = 500 μs	3	V
V <sub>FP</sub>	10/700 μs	V <sub>PP</sub> = 1.5 kV R <sub>S</sub> = 15 Ω	5	V

**Table 5. Parameters related to the protection thyristors (T<sub>amb</sub> = 25 °C)**

Symbol	Test conditions	Min.	Max.	Unit
I <sub>GT</sub>	V <sub>LINE</sub> = -48 V	0.1	5	mA
I <sub>H</sub>	V <sub>Gn</sub> = -48 V	150		mA
I <sub>RG</sub>	V <sub>RG</sub> = -75 V		5	μA
V <sub>DGL</sub>	V <sub>Gn</sub> = -48 V <sup>(1)</sup> 10/700 μs V <sub>PP</sub> = 1.5 kV R <sub>S</sub> = 15 Ω I <sub>PP</sub> = 27.5 A		7	V

1. The oscillations with a time duration lower than 50 ns are not taken into account.

**Table 6. Parameters related to diode and protection thyristors (T<sub>amb</sub> = 25 °C,)**

Symbol	Test conditions	Typ.	Max.	Unit
I <sub>R</sub>	V <sub>Gn / LINE</sub> = -1 V V <sub>RM</sub> = -75 V T <sub>j</sub> = 25 °C		5	μA
C	V <sub>LINE</sub> = -50 V, V <sub>RMS</sub> = 1 V, F = 1 MHz V <sub>LINE</sub> = -2 V, V <sub>RMS</sub> = 1 V, F = 1 MHz	15 35		pF

**Table 7. Recommended gate capacitance**

Symbol	Component	Min.	Typ.	Max.	Unit
C <sub>G</sub>	Gate decoupling capacitance	100	220		nF

## 2 Technical information

Figure 4. LCP1531 concept behavior

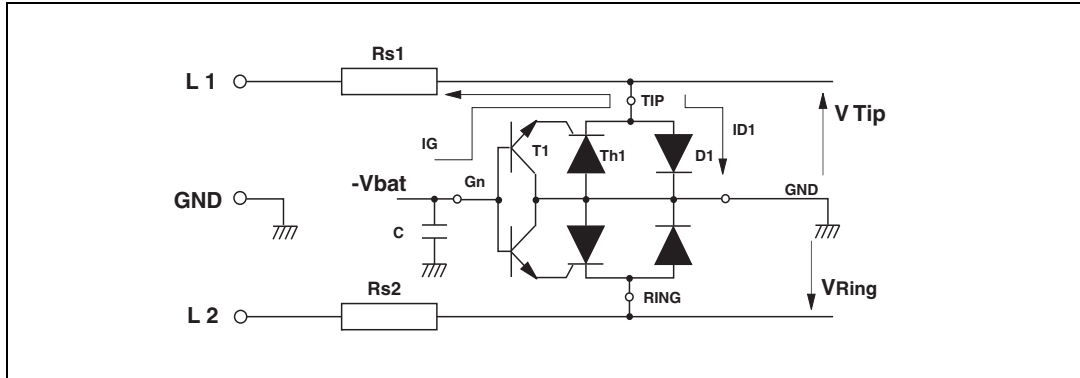

Figure 4. shows the classical protection circuit using the LCP1531 crowbar concept. This topology has been developed to protect the new high voltage SLICs. It allows to program the negative firing threshold while the positive clamping value is fixed at GND.

When a negative surge occurs on one wire (L1 for example) a current  $I_G$  flows through the base of the transistor T1 and then injects a current in the gate of the thyristor Th1. Th1 fires and all the surge current flows through the ground. After the surge when the current flowing through Th1 becomes less negative than the holding current  $I_H$ , then Th1 switches off.

When a positive surge occurs on one wire (L1 for example) the diode D1 conducts and the surge current flows through the ground.

Figure 5. Example of PCB layout based on LCP1531 protection

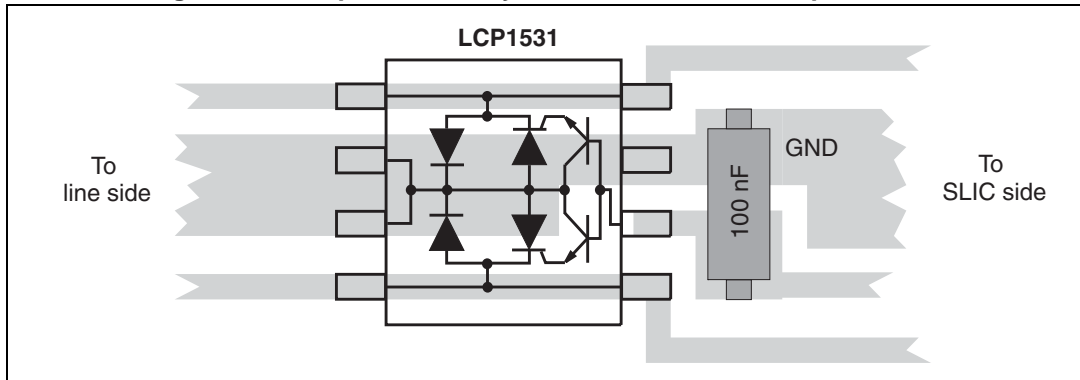

Figure 5. shows the classical PCB layout used to optimize line protection.

The capacitor C is used to speed up the crowbar structure firing during the fast surge edges.

This allows minimization of the dynamic breakover voltage at the SLIC Tip and Ring inputs during fast strikes. Note that this capacitor is generally present around the SLIC -  $V_{bat}$  pin.

So to be efficient it has to be as close as possible from the LCP1531 Gate pin and from the reference ground track (or plan) (see Figure 5.). The optimized value for C is 100 nF.

The series resistors Rs1 and Rs2 designed in *Figure 4*. represent the fuse resistors or the PTC which are mandatory to withstand the power contact or the power induction tests imposed by the various country standards. Taking into account this fact the actual lightning surge current flowing through the LCP1531 is equal to:

$$I_{surge} = V_{surge} / (R_g + R_s)$$

With:

$V_{surge}$  = peak surge voltage imposed by the standard.

$R_g$  = series resistor of the surge generator

$R_s$  = series resistor of the line card (e.g. PTC)

The LCP1531 is particularly optimized for the new telecom applications such as the fiber in the loop, the WLL, the remote central office. In this case, the operating voltages are smaller than in the classical system. This makes the high voltage SLICs particularly suitable.

The schematics of *Figure 6*. gives the most frequent topology used for these applications.

**Figure 6. Protection of high voltage SLIC**

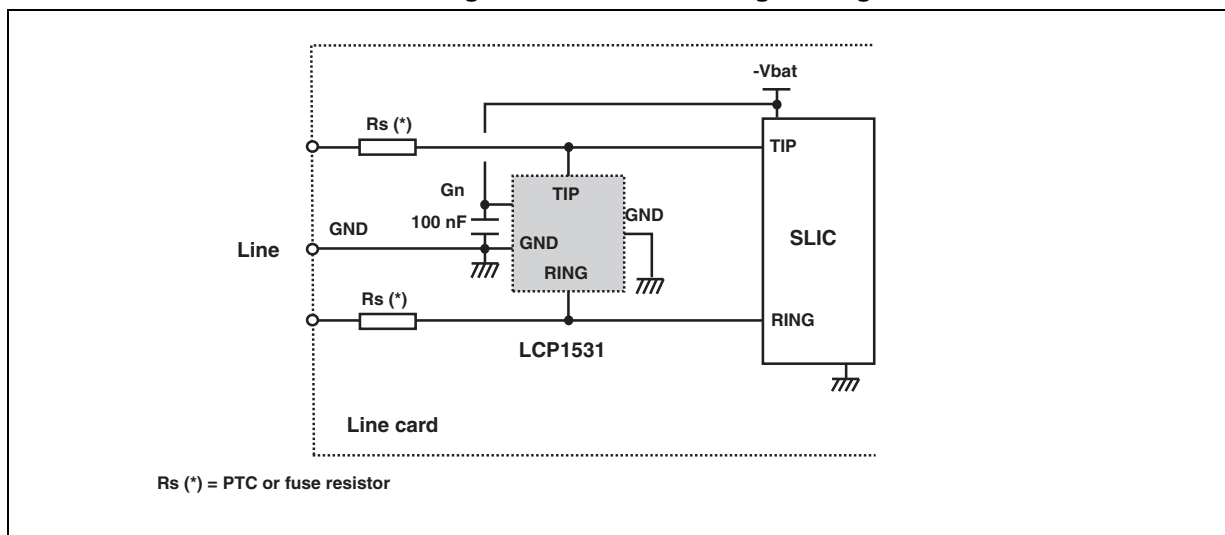

**Figure 7. Surge peak current versus overload duration**

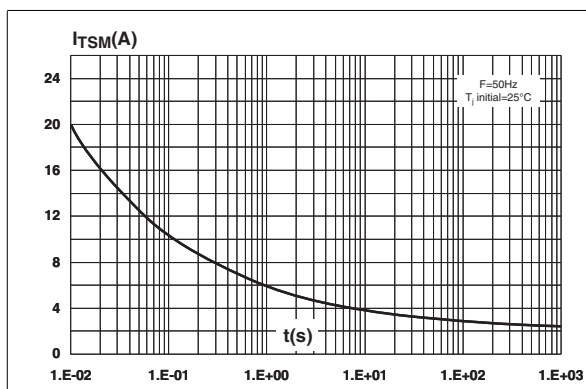

**Figure 8. Relative variation of holding current versus junction temperature**

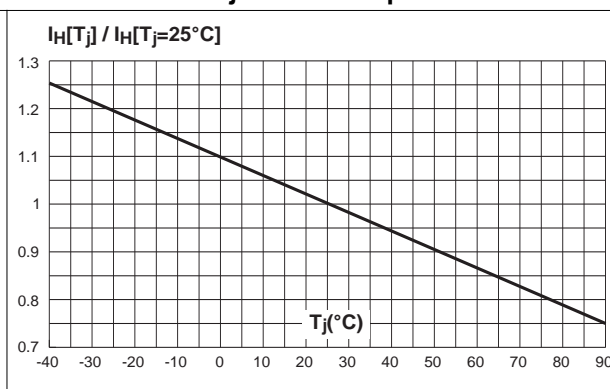

### 3 Package information

- Epoxy meets UL94, V0
- Lead-free packages

In order to meet environmental requirements, ST offers these devices in different grades of ECOPACK<sup>®</sup> packages, depending on their level of environmental compliance. ECOPACK<sup>®</sup> specifications, grade definitions and product status are available at: [www.st.com](http://www.st.com). ECOPACK<sup>®</sup> is an ST trademark.

Figure 9. SO-8 dimension definitions

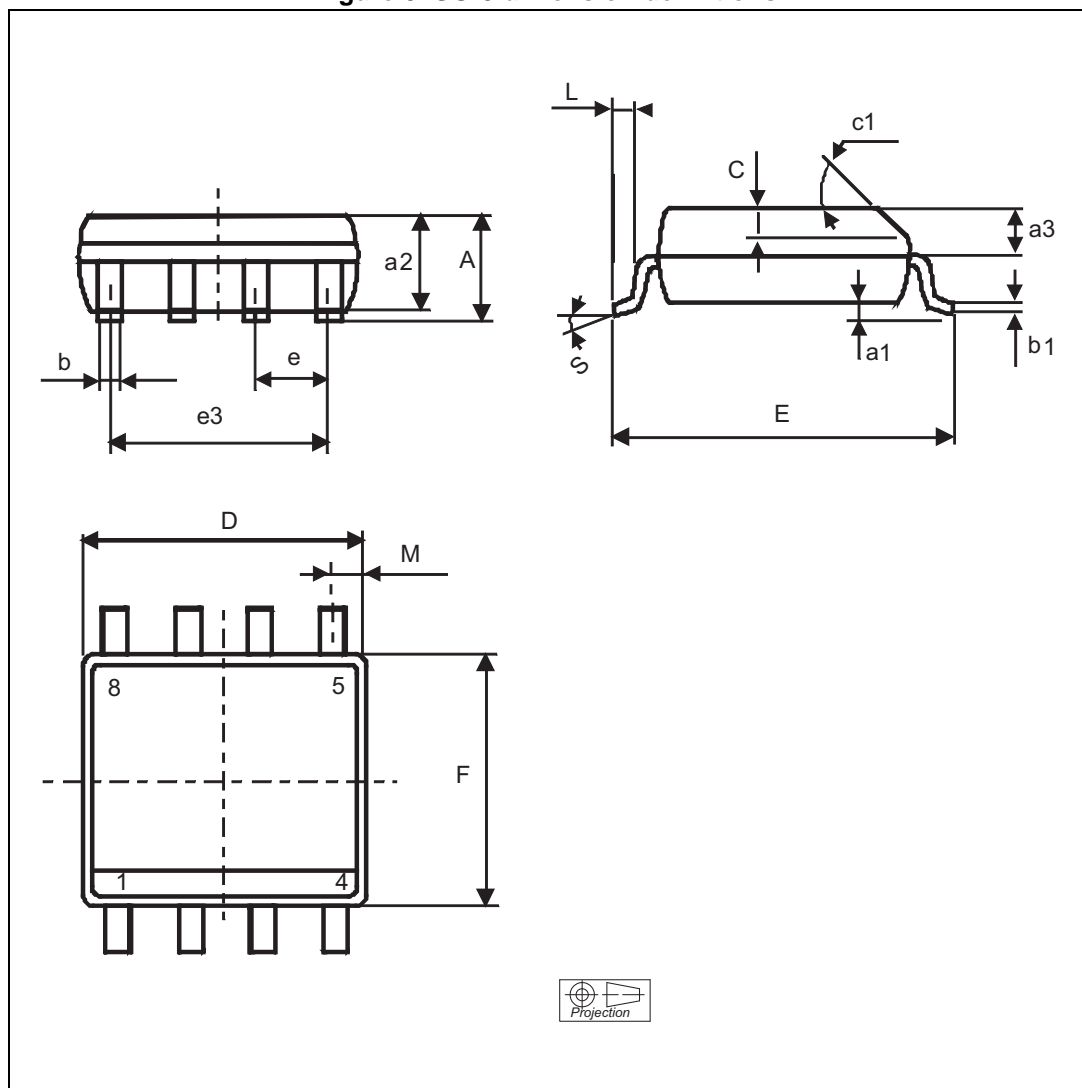
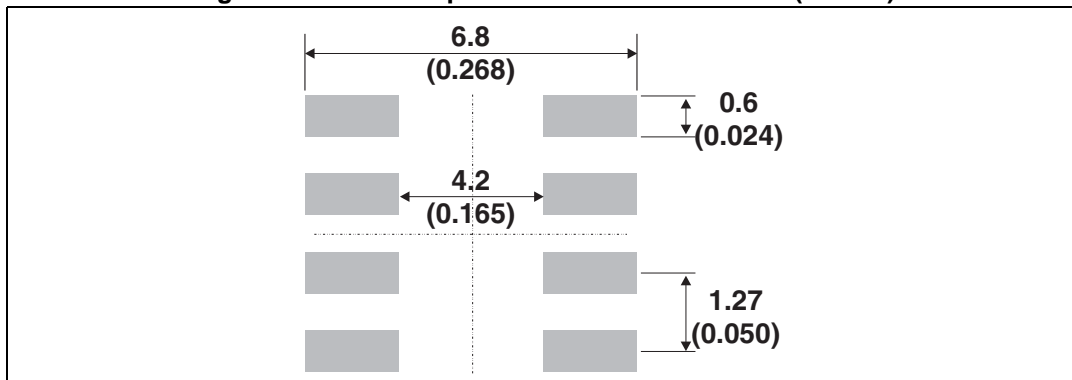

Table 8. SO-8 dimension values

Ref.	Dimensions					
	Millimeters			Inches		
	Min.	Typ.	Max.	Min.	Typ.	Max.
A			1.75			0.069
A1	0.1		0.25	0.004		0.010
A2	1.25			0.049		
b	0.28		0.48	0.011		0.019
C	0.17		0.23	0.007		0.009
D	4.80	4.90	5.00	0.189	0.193	0.197
E	5.80	6.00	6.20	0.228	0.236	0.244
E1	3.80	3.90	4.00	0.150	0.154	0.157
e		1.27			0.050	
h	0.25		0.50	0.010		0.020
L	0.40		1.27	0.016		0.050
L1		1.04			0.041	
k°	0		8	0		8
ccc			0.10			0.004

Figure 10. SO-8 footprint measurements in mm (inches)





## 4 Ordering information

**Table 9. Ordering information**

Order code	Marking	Package	Weight	Base qty	Delivery mode
LCP1531RL	CP153	SO-8	0.08 g	2500	Tape and reel

## 5 Revision history

**Table 10. Document revision history**

Date	Revision	Changes
23-Mar-2007	1	First issue.
10-Apr-2008	2	Reformatted for current standards. Changed gate capacitance from 220 nF to 100 nF.
10-Aug-2011	3	Updated standards in <a href="#">Table 1</a> .
23-Feb-2012	4	Standardized nomenclature for Gn.
27-Aug-2013	5	Updated <a href="#">Table 1</a> , <a href="#">Table 3</a> , <a href="#">Figure 9</a> and <a href="#">Figure 10</a> .

**Please Read Carefully:**

Information in this document is provided solely in connection with ST products. STMicroelectronics NV and its subsidiaries ("ST") reserve the right to make changes, corrections, modifications or improvements, to this document, and the products and services described herein at any time, without notice.

All ST products are sold pursuant to ST's terms and conditions of sale.

Purchasers are solely responsible for the choice, selection and use of the ST products and services described herein, and ST assumes no liability whatsoever relating to the choice, selection or use of the ST products and services described herein.

No license, express or implied, by estoppel or otherwise, to any intellectual property rights is granted under this document. If any part of this document refers to any third party products or services it shall not be deemed a license grant by ST for the use of such third party products or services, or any intellectual property contained therein or considered as a warranty covering the use in any manner whatsoever of such third party products or services or any intellectual property contained therein.

**UNLESS OTHERWISE SET FORTH IN ST'S TERMS AND CONDITIONS OF SALE ST DISCLAIMS ANY EXPRESS OR IMPLIED WARRANTY WITH RESPECT TO THE USE AND/OR SALE OF ST PRODUCTS INCLUDING WITHOUT LIMITATION IMPLIED WARRANTIES OF MERCHANTABILITY, FITNESS FOR A PARTICULAR PURPOSE (AND THEIR EQUIVALENTS UNDER THE LAWS OF ANY JURISDICTION), OR INFRINGEMENT OF ANY PATENT, COPYRIGHT OR OTHER INTELLECTUAL PROPERTY RIGHT.**

**ST PRODUCTS ARE NOT AUTHORIZED FOR USE IN WEAPONS. NOR ARE ST PRODUCTS DESIGNED OR AUTHORIZED FOR USE IN: (A) SAFETY CRITICAL APPLICATIONS SUCH AS LIFE SUPPORTING, ACTIVE IMPLANTED DEVICES OR SYSTEMS WITH PRODUCT FUNCTIONAL SAFETY REQUIREMENTS; (B) AERONAUTIC APPLICATIONS; (C) AUTOMOTIVE APPLICATIONS OR ENVIRONMENTS, AND/OR (D) AEROSPACE APPLICATIONS OR ENVIRONMENTS. WHERE ST PRODUCTS ARE NOT DESIGNED FOR SUCH USE, THE PURCHASER SHALL USE PRODUCTS AT PURCHASER'S SOLE RISK, EVEN IF ST HAS BEEN INFORMED IN WRITING OF SUCH USAGE, UNLESS A PRODUCT IS EXPRESSLY DESIGNATED BY ST AS BEING INTENDED FOR "AUTOMOTIVE, AUTOMOTIVE SAFETY OR MEDICAL" INDUSTRY DOMAINS ACCORDING TO ST PRODUCT DESIGN SPECIFICATIONS. PRODUCTS FORMALLY ESCC, QML OR JAN QUALIFIED ARE DEEMED SUITABLE FOR USE IN AEROSPACE BY THE CORRESPONDING GOVERNMENTAL AGENCY.**

Resale of ST products with provisions different from the statements and/or technical features set forth in this document shall immediately void any warranty granted by ST for the ST product or service described herein and shall not create or extend in any manner whatsoever, any liability of ST.

ST and the ST logo are trademarks or registered trademarks of ST in various countries.

Information in this document supersedes and replaces all information previously supplied.

The ST logo is a registered trademark of STMicroelectronics. All other names are the property of their respective owners.

© 2013 STMicroelectronics - All rights reserved

STMicroelectronics group of companies

Australia - Belgium - Brazil - Canada - China - Czech Republic - Finland - France - Germany - Hong Kong - India - Israel - Italy - Japan - Malaysia - Malta - Morocco - Philippines - Singapore - Spain - Sweden - Switzerland - United Kingdom - United States of America

[www.st.com](http://www.st.com)

## X-ON Electronics

Largest Supplier of Electrical and Electronic Components

*Click to view similar products for [Triacs](#) category:*

*Click to view products by [STMicroelectronics](#) manufacturer:*

Other Similar products are found below :

[CTA08-1000CW](#) [CTB24-800BW](#) [CTA08-1000C](#) [CTA12-800BWPT](#) [CTA16-1000B](#) [CTB24-800B](#) [BT137-600-0Q](#) [5615](#) [OT415Q](#) [2N6075A](#)  
[NTE5629](#) [NTE5688](#) [CTB08-400CW](#) [D31410](#) [T2535T-8I](#) [BTA425Z-800BTQ](#) [KS100N12](#) [TOPT16-800C0,127](#) [OT408,135](#) [BT134-800E](#)  
[BT136D](#) [BTB16Q-600BW](#) [Z0409MF](#) [BTA04-600B](#) [BTA06-600BRG](#) [BTA06-800BWRG](#) [BTA08-600BRG](#) [BTA08-800B](#) [BT136-600,127](#)  
[MAC97A6,116](#) [BT137-600E,127](#) [BTB16-600CW3G](#) [BTB16-600CW3G](#) [Z0109MN,135](#) [T825T-6I](#) [T1220T-6I](#) [NTE5638](#) [ACST1235-8FP](#)  
[BT136X-600E,127](#) [BT134-600D,127](#) [BTA08-600BW3G](#) [NTE56008](#) [NTE56017](#) [NTE56018](#) [NTE56059](#) [NTE5608](#) [NTE5609](#) [NTE5656](#)  
[NTE56020](#) [NTE56022](#)