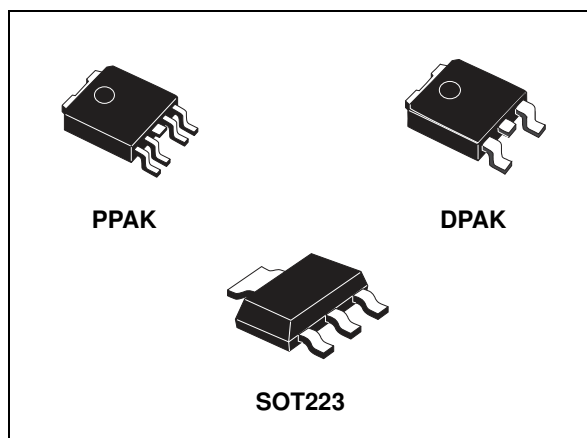

800 mA fixed and adjustable output very low drop voltage regulator

Datasheet - production data

Description

The LD29080 is a medium current, high accuracy, low-dropout voltage regulators series. These regulators feature 400 mV dropout voltage and very low ground current. Designed for medium current loads, these devices also find applications in lower current, extremely low dropout-critical systems, where their tiny dropout voltage and ground current values are important attributes. Typical application are in power supply switching post regulation, series power supply for monitors, series power supply for VCRs and TVs, computer systems and battery powered systems.

Features

- Very low dropout voltage (typ. 0.4 at 800 mA)
- Guaranteed output current up to 800 mA
- Fixed and adjustable output voltage ($\pm 1\%$ at 25 °C)
- Internal current and thermal limit
- Logic controlled electronic shutdown

Table 1. Device summary

Order codes			Output voltages
DPAK (tape and reel)	PPAK (tape and reel)	SOT223	
LD29080DT15R	LD29080PT15R		1.5 V
LD29080DT18R	LD29080PT18R		1.8 V
LD29080DT25R	LD29080PT25R		2.5 V
LD29080DT33R	LD29080PT33R	LD29080S33R	3.3 V
LD29080DT50R	LD29080PT50R		5.0 V
LD29080DT90R	LD29080PT90R		9.0 V
	LD29080PTR		ADJ

Contents

1	Diagram	3
2	Pin configuration	4
3	Maximum ratings	5
4	Electrical characteristics	6
5	Typical characteristics	14
6	Package mechanical data	17
7	Packaging mechanical data	23
8	Revision history	25

1 Diagram

Figure 1. Schematic diagram for adjustable version

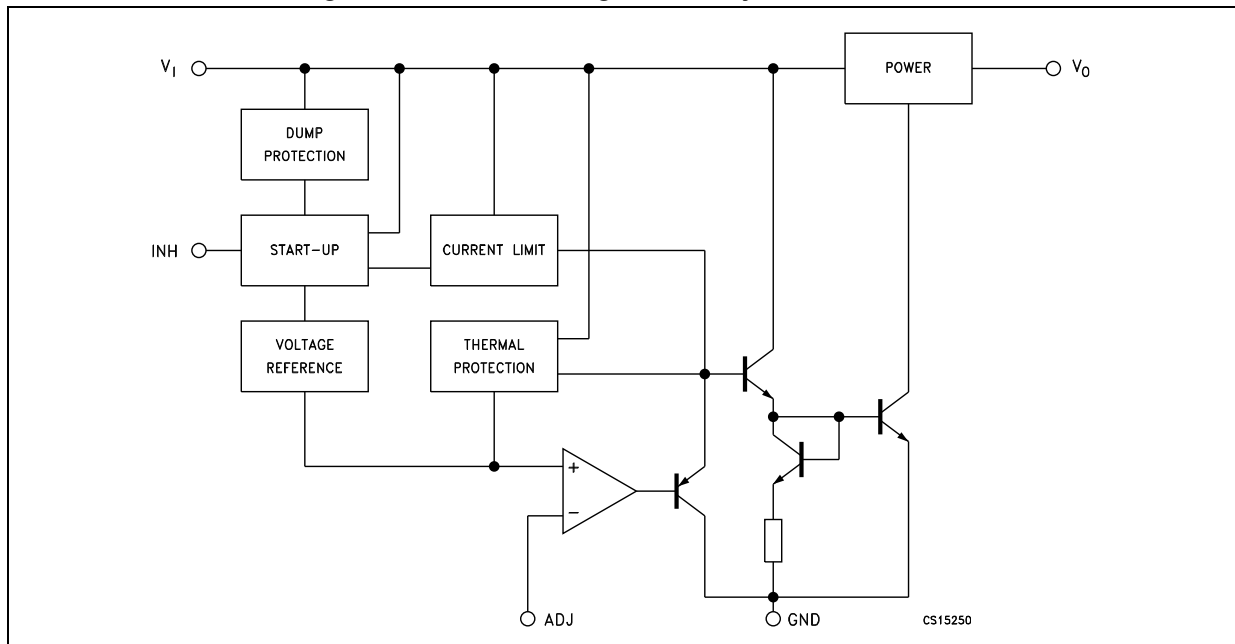
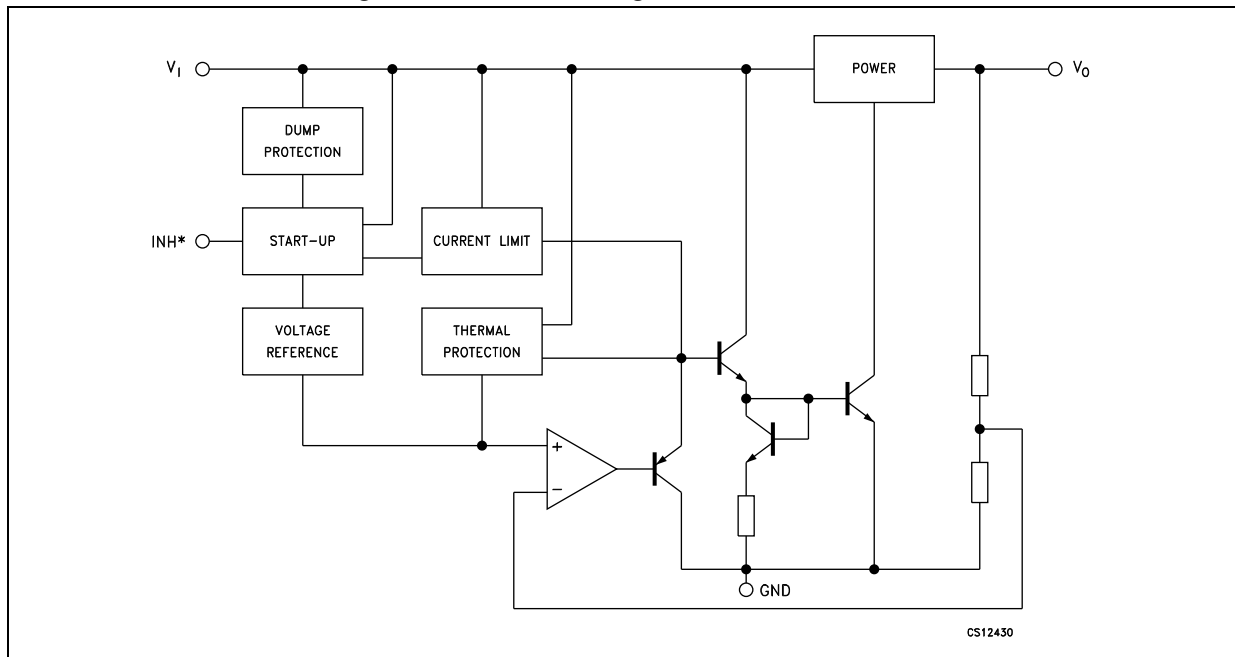

Figure 2. Schematic diagram for fixed version



* Only for version with inhibit function.

2 Pin configuration

Figure 3. Pin connections (top view)

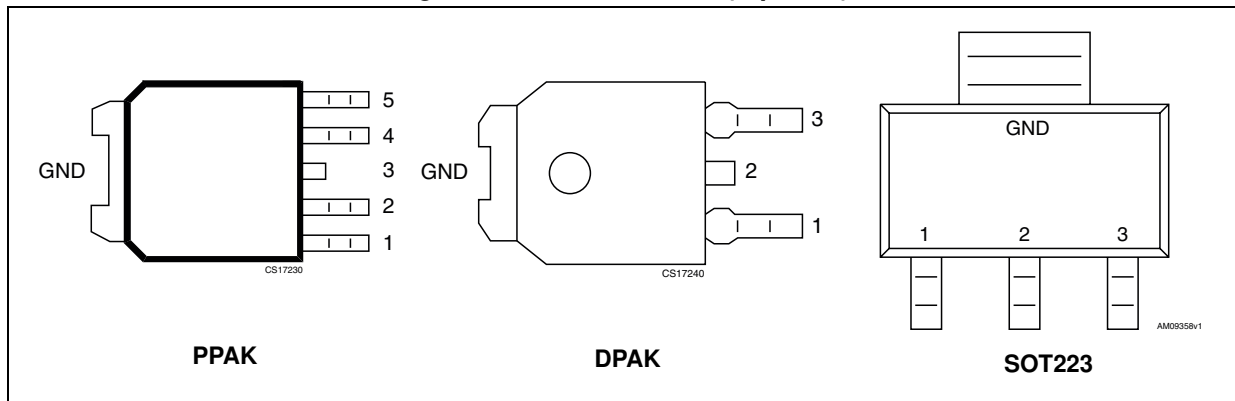
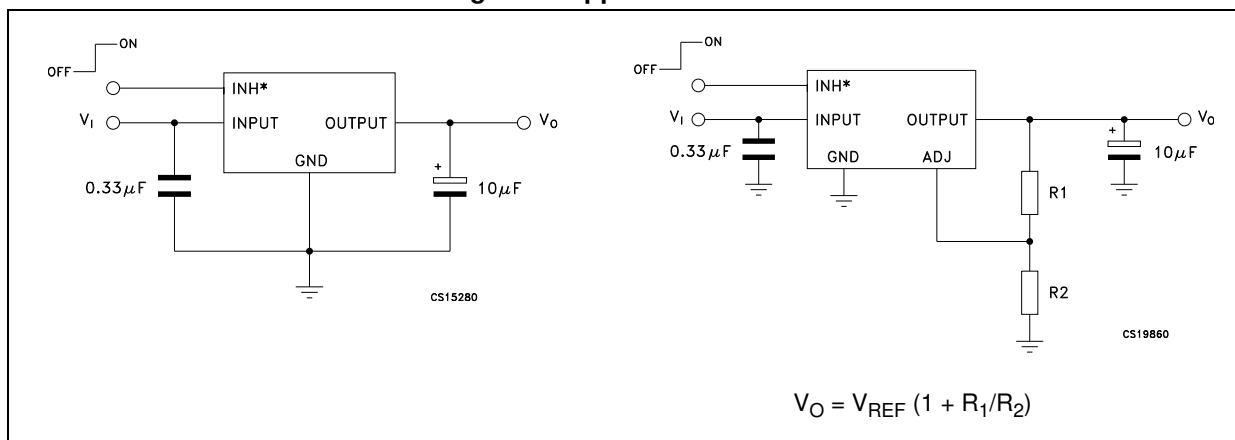

Table 2. Pin description

Symbol	PPAK	DPAK	SOT223
V_I	2	1	1
GND	3	2	2
V_O	4	3	3
ADJ/N.C. ⁽¹⁾	5		
INHIBIT ⁽²⁾	1		

1. Not connected for fixed version.
2. Not internally pulled up; in order to assure the operating condition (device in ON mode), it must be connected to a positive voltage higher than 2 V.

Figure 4. Application circuit



* Only for version with inhibit function.

3 Maximum ratings

Table 3. Absolute maximum ratings

Symbol	Parameter	Value	Unit
V_I	DC input voltage	30 ⁽¹⁾	V
V_{INH}	Inhibit input voltage	14	V
I_O	Output current	Internally limited	mA
P_D	Power dissipation	Internally limited	mW
T_{STG}	Storage temperature range	- 55 to 150	°C
T_{OP}	Operating temperature range	- 40 to 125	°C

1. Above 14 V the device is automatically in shut-down.

Note: Absolute maximum ratings are those values beyond which damage to the device may occur. Functional operation under these conditions is not implied.

Table 4. Thermal data

Symbol	Parameter	DPAK	PPAK	SOT223	Unit
R_{thJC}	Thermal resistance junction-case	8	8	25	°C/W
R_{thJA}	Thermal resistance junction-ambient	100	100	110	°C/W

4 Electrical characteristics

$I_O = 10 \text{ mA}$, (*Note 4*) $T_J = 25 \text{ }^\circ\text{C}$, $V_I = 3.5 \text{ V}$, $V_{INH} = 2\text{V}$, $C_I = 330 \text{ nF}$, $C_O = 10 \text{ } \mu\text{F}$, unless otherwise specified.

Table 5. Electrical characteristics of LD29080#15

Symbol	Parameter	Test conditions	Min.	Typ.	Max.	Unit
V_I	Operating input voltage	$I_O = 10 \text{ mA to } 800 \text{ mA}$	2.5		13	V
V_O	Output voltage	$I_O = 10 \text{ mA to } 800 \text{ mA}$, $V_I = 3 \text{ to } 7 \text{ V}$ $T_J = -40 \text{ to } 125 \text{ }^\circ\text{C}$	1.485	1.5	1.515	V
			1.463		1.537	
ΔV_O	Load regulation	$I_O = 10 \text{ mA to } 800 \text{ mA}$		0.2	1.0	%
ΔV_O	Line regulation	$V_I = 3 \text{ to } 13 \text{ V}$		0.06	0.5	%
SVR	Supply voltage rejection	$f = 120 \text{ Hz}$, $V_I = 3.8 \pm 1 \text{ V}$, $I_O = 400 \text{ mA}$ (<i>Note 1</i>)	65	75		dB
I_q	Quiescent current	$I_O = 10 \text{ mA}$, $T_J = -40 \text{ to } 125 \text{ }^\circ\text{C}$		2	5	mA
		$I_O = 400 \text{ mA}$, $T_J = -40 \text{ to } 125 \text{ }^\circ\text{C}$		8	20	
		$I_O = 800 \text{ mA}$, $T_J = -40 \text{ to } 125 \text{ }^\circ\text{C}$		14	35	
		$V_I = 13 \text{ V}$, $V_{INH} = \text{GND}$, $T_J = -40 \text{ to } 125 \text{ }^\circ\text{C}$		130	180	μA
I_{sc}	Short circuit current	$R_L = 0$		1.2		A
V_{IL}	Control input logic low	OFF MODE, $T_J = -40 \text{ to } 125 \text{ }^\circ\text{C}$			0.8	V
V_{IH}	Control input logic high	ON MODE, $T_J = -40 \text{ to } 125 \text{ }^\circ\text{C}$	2			V
I_{INH}	Control input current	$V_{INH} = 13\text{V}$, $T_J = -40 \text{ to } 125 \text{ }^\circ\text{C}$		5	10	μA
eN	Output noise voltage	$B_P = 10 \text{ Hz to } 100 \text{ kHz}$, $I_O = 100 \text{ mA}$ (<i>Note 1</i>)		60		μV_{RMS}

- Note:*
- 1 Guaranteed by design.
 - 2 Dropout voltage is defined as the input-to-output differential when the output voltage drops to 99% of its nominal value with $V_O + 1 \text{ V}$ applied to V_I .
 - 3 Reference voltage is measured between output and GND pins, with ADJ PIN tied to V_O .
 - 4 In order to avoid any output voltage rise within the whole operating temperature range, due to output leakage current, a minimum load current of 2 mA is required.

$I_O = 10 \text{ mA}$, (*Note 4*) $T_J = 25 \text{ }^\circ\text{C}$, $V_I = 3.5 \text{ V}$, $V_{INH} = 2 \text{ V}$, $C_I = 330 \text{ nF}$, $C_O = 10 \text{ } \mu\text{F}$, unless otherwise specified.

Table 6. Electrical characteristics of LD29080#18

Symbol	Parameter	Test conditions	Min.	Typ.	Max.	Unit
V_I	Operating input voltage	$I_O = 10 \text{ mA to } 800 \text{ mA}$	2.5		13	V
V_O	Output voltage	$I_O = 10 \text{ mA to } 800 \text{ mA}$, $V_I = 3 \text{ to } 7.3 \text{ V}$ $T_J = -40 \text{ to } 125 \text{ }^\circ\text{C}$	1.782	1.8	1.818	V
			1.755		1.845	
ΔV_O	Load regulation	$I_O = 10 \text{ mA to } 800 \text{ mA}$		0.2	1.0	%
ΔV_O	Line regulation	$V_I = 3 \text{ to } 13 \text{ V}$		0.06	0.5	%
SVR	Supply voltage rejection	$f = 120 \text{ Hz}$, $V_I = 3.8 \pm 1 \text{ V}$, $I_O = 400 \text{ mA}$ (<i>Note 1</i>)	62	72		dB
V_{DROPO}	Dropout voltage	$I_O = 150 \text{ mA}$, $T_J = -40 \text{ to } 125 \text{ }^\circ\text{C}$ (<i>Note 2</i>)		0.1		V
		$I_O = 400 \text{ mA}$, $T_J = -40 \text{ to } 125 \text{ }^\circ\text{C}$ (<i>Note 2</i>)		0.2		
		$I_O = 800 \text{ mA}$, $T_J = -40 \text{ to } 125 \text{ }^\circ\text{C}$ (<i>Note 2</i>)		0.4	0.7	
I_q	Quiescent current	$I_O = 10 \text{ mA}$, $T_J = -40 \text{ to } 125 \text{ }^\circ\text{C}$		2	5	mA
		$I_O = 400 \text{ mA}$, $T_J = -40 \text{ to } 125 \text{ }^\circ\text{C}$		8	20	
		$I_O = 800 \text{ mA}$, $T_J = -40 \text{ to } 125 \text{ }^\circ\text{C}$		14	35	
		$V_I = 13 \text{ V}$, $V_{INH} = \text{GND}$, $T_J = -40 \text{ to } 125 \text{ }^\circ\text{C}$		130	180	μA
I_{sc}	Short circuit current	$R_L = 0$		1.2		A
V_{IL}	Control input logic low	OFF MODE, $T_J = -40 \text{ to } 125 \text{ }^\circ\text{C}$			0.8	V
V_{IH}	Control input logic high	ON MODE, $T_J = -40 \text{ to } 125 \text{ }^\circ\text{C}$	2			V
I_{INH}	Control input current	$V_{INH} = 13 \text{ V}$, $T_J = -40 \text{ to } 125 \text{ }^\circ\text{C}$		5	10	μA
eN	Output noise voltage	$B_p = 10 \text{ Hz to } 100 \text{ kHz}$, $I_O = 100 \text{ mA}$ (<i>Note 1</i>)		72		μV_{RMS}

- Note:*
- 1 Guaranteed by design.
 - 2 Dropout voltage is defined as the input-to-output differential when the output voltage drops to 99% of its nominal value with $V_O + 1 \text{ V}$ applied to V_I .
 - 3 Reference voltage is measured between output and GND pins, with ADJ PIN tied to V_O .
 - 4 In order to avoid any output voltage rise within the whole operating temperature range, due to output leakage current, a minimum load current of 2 mA is required.

$I_O = 10 \text{ mA}$, (*Note 4*) $T_J = 25 \text{ }^\circ\text{C}$, $V_I = 4.5 \text{ V}$, $V_{INH} = 2 \text{ V}$, $C_I = 330 \text{ nF}$, $C_O = 10 \text{ } \mu\text{F}$, unless otherwise specified.

Table 7. Electrical characteristics of LD29080#25

Symbol	Parameter	Test conditions	Min.	Typ.	Max.	Unit
V_I	Operating input voltage	$I_O = 10 \text{ mA}$ to 800 mA			13	V
V_O	Output voltage	$I_O = 10 \text{ mA}$ to 800 mA , $V_I = 3.5$ to 8 V $T_J = -40$ to $125 \text{ }^\circ\text{C}$	2.475	2.5	2.525	V
			2.438		2.562	
ΔV_O	Load regulation	$I_O = 10 \text{ mA}$ to 800 mA		0.2	1.0	%
ΔV_O	Line regulation	$V_I = 3.5$ to 13 V		0.06	0.5	%
SVR	Supply voltage rejection	$f = 120 \text{ Hz}$, $V_I = 4.5 \pm 1 \text{ V}$, $I_O = 400 \text{ mA}$ (<i>Note 1</i>)	55	70		dB
V_{DROPO}	Dropout voltage	$I_O = 150 \text{ mA}$, $T_J = -40$ to $125 \text{ }^\circ\text{C}$ (<i>Note 2</i>)		0.1		V
		$I_O = 400 \text{ mA}$, $T_J = -40$ to $125 \text{ }^\circ\text{C}$ (<i>Note 2</i>)		0.2		
		$I_O = 800 \text{ mA}$, $T_J = -40$ to $125 \text{ }^\circ\text{C}$ (<i>Note 2</i>)		0.4	0.7	
I_q	Quiescent current	$I_O = 10 \text{ mA}$, $T_J = -40$ to $125 \text{ }^\circ\text{C}$		2	5	mA
		$I_O = 400 \text{ mA}$, $T_J = -40$ to $125 \text{ }^\circ\text{C}$		8	20	
		$I_O = 800 \text{ mA}$, $T_J = -40$ to $125 \text{ }^\circ\text{C}$		14	35	
		$V_I = 13 \text{ V}$, $V_{INH} = \text{GND}$, $T_J = -40$ to $125 \text{ }^\circ\text{C}$		130	180	μA
I_{sc}	Short circuit current	$R_L = 0$		1.2		A
V_{IL}	Control input logic low	OFF MODE, $T_J = -40$ to $125 \text{ }^\circ\text{C}$			0.8	V
V_{IH}	Control input logic high	ON MODE, $T_J = -40$ to $125 \text{ }^\circ\text{C}$	2			V
I_{INH}	Control input current	$V_{INH} = 13 \text{ V}$, $T_J = -40$ to $125 \text{ }^\circ\text{C}$		5	10	μA
eN	Output noise voltage	$B_p = 10 \text{ Hz}$ to 100 kHz , $I_O = 100 \text{ mA}$ (<i>Note 1</i>)		100		μV_{RMS}

- Note:*
- 1 Guaranteed by design.
 - 2 Dropout voltage is defined as the input-to-output differential when the output voltage drops to 99% of its nominal value with $V_O + 1 \text{ V}$ applied to V_I .
 - 3 Reference voltage is measured between output and GND pins, with ADJ PIN tied to V_O .
 - 4 In order to avoid any output voltage rise within the whole operating temperature range, due to output leakage current, a minimum load current of 2 mA is required.

$I_O = 10 \text{ mA}$, (*Note 4*) $T_J = 25 \text{ }^\circ\text{C}$, $V_I = 5.3 \text{ V}$, $V_{INH} = 2 \text{ V}$, $C_I = 330 \text{ nF}$, $C_O = 10 \text{ } \mu\text{F}$, unless otherwise specified.

Table 8. Electrical characteristics of LD29080#33

Symbol	Parameter	Test conditions	Min.	Typ.	Max.	Unit
V_I	Operating input voltage	$I_O = 10\text{mA}$ to 800mA			13	V
V_O	Output voltage	$I_O = 10 \text{ mA}$ to 800 mA , $V_I = 4.3$ to 8.8 V $T_J = -40$ to $125 \text{ }^\circ\text{C}$	3.267	3.3	3.333	V
			3.218		3.382	
ΔV_O	Load regulation	$I_O = 10 \text{ mA}$ to 800 mA		0.2	1.0	%
ΔV_O	Line regulation	$V_I = 4.3$ to 13 V		0.06	0.5	%
SVR	Supply voltage rejection	$f = 120 \text{ Hz}$, $V_I = 5.3 \pm 1 \text{ V}$, $I_O = 400 \text{ mA}$ (<i>Note 1</i>)	52	67		dB
V_{DROPP}	Dropout voltage	$I_O = 150 \text{ mA}$, $T_J = -40$ to $125 \text{ }^\circ\text{C}$ (<i>Note 2</i>)		0.1		V
		$I_O = 400 \text{ mA}$, $T_J = -40$ to $125 \text{ }^\circ\text{C}$ (<i>Note 2</i>)		0.2		
		$I_O = 800 \text{ mA}$, $T_J = -40$ to $125 \text{ }^\circ\text{C}$ (<i>Note 2</i>)		0.4	0.7	
I_q	Quiescent current	$I_O = 10 \text{ mA}$, $T_J = -40$ to $125 \text{ }^\circ\text{C}$		2	5	mA
		$I_O = 400 \text{ mA}$, $T_J = -40$ to $125 \text{ }^\circ\text{C}$		8	20	
		$I_O = 800 \text{ mA}$, $T_J = -40$ to $125 \text{ }^\circ\text{C}$		14	35	
		$V_I = 13 \text{ V}$, $V_{INH} = \text{GND}$, $T_J = -40$ to $125 \text{ }^\circ\text{C}$		130	180	μA
I_{sc}	Short circuit current	$R_L = 0$		1.2		A
V_{IL}	Control input logic low	OFF MODE, $T_J = -40$ to $125 \text{ }^\circ\text{C}$			0.8	V
V_{IH}	Control input logic high	ON MODE, $T_J = -40$ to $125 \text{ }^\circ\text{C}$	2			V
I_{INH}	Control input current	$V_{INH} = 13 \text{ V}$, $T_J = -40$ to $125 \text{ }^\circ\text{C}$		5	10	μA
eN	Output noise voltage	$B_p = 10 \text{ Hz}$ to 100 kHz , $I_O = 100 \text{ mA}$ (<i>Note 1</i>)		132		μV_{RMS}

- Note:*
- 1 Guaranteed by design.
 - 2 Dropout voltage is defined as the input-to-output differential when the output voltage drops to 99% of its nominal value with $V_O + 1 \text{ V}$ applied to V_I .
 - 3 Reference voltage is measured between output and GND pins, with ADJ PIN tied to V_O .
 - 4 In order to avoid any output voltage rise within the whole operating temperature range, due to output leakage current, a minimum load current of 2 mA is required.

$I_O = 10 \text{ mA}$, (*Note 4*) $T_J = 25 \text{ }^\circ\text{C}$, $V_I = 7 \text{ V}$, $V_{INH} = 2 \text{ V}$, $C_I = 330 \text{ nF}$, $C_O = 10 \text{ } \mu\text{F}$, unless otherwise specified.

Table 9. Electrical characteristics of LD29080#50

Symbol	Parameter	Test conditions	Min.	Typ.	Max.	Unit
V_I	Operating input voltage	$I_O = 10 \text{ mA to } 800 \text{ mA}$			13	V
V_O	Output voltage	$I_O = 10 \text{ mA to } 800 \text{ mA}$, $V_I = 6 \text{ to } 10.5 \text{ V}$ $T_J = -40 \text{ to } 125 \text{ }^\circ\text{C}$	4.95	5	5.05	V
			4.875		5.125	
ΔV_O	Load regulation	$I_O = 10 \text{ mA to } 800 \text{ mA}$		0.2	1.0	%
ΔV_O	Line regulation	$V_I = 6 \text{ to } 13 \text{ V}$		0.06	0.5	%
SVR	Supply voltage rejection	$f = 120 \text{ Hz}$, $V_I = 7 \pm 1 \text{ V}$, $I_O = 400 \text{ mA}$ (<i>Note 1</i>)	49	64		dB
V_{DROPO}	Dropout voltage	$I_O = 150 \text{ mA}$, $T_J = -40 \text{ to } 125 \text{ }^\circ\text{C}$ (<i>Note 2</i>)		0.1		V
		$I_O = 400 \text{ mA}$, $T_J = -40 \text{ to } 125 \text{ }^\circ\text{C}$ (<i>Note 2</i>)		0.2		
		$I_O = 800 \text{ mA}$, $T_J = -40 \text{ to } 125 \text{ }^\circ\text{C}$ (<i>Note 2</i>)		0.4	0.7	
I_q	Quiescent current	$I_O = 10 \text{ mA}$, $T_J = -40 \text{ to } 125 \text{ }^\circ\text{C}$		2	5	mA
		$I_O = 400 \text{ mA}$, $T_J = -40 \text{ to } 125 \text{ }^\circ\text{C}$		8	20	
		$I_O = 800 \text{ mA}$, $T_J = -40 \text{ to } 125 \text{ }^\circ\text{C}$		14	35	
		$V_I = 13 \text{ V}$, $V_{INH} = \text{GND}$, $T_J = -40 \text{ to } 125 \text{ }^\circ\text{C}$		130	180	μA
I_{sc}	Short circuit current	$R_L = 0$		1.2		A
V_{IL}	Control input logic low	OFF MODE, $T_J = -40 \text{ to } 125 \text{ }^\circ\text{C}$			0.8	V
V_{IH}	Control input logic high	ON MODE, $T_J = -40 \text{ to } 125 \text{ }^\circ\text{C}$	2			V
I_{INH}	Control input current	$V_{INH} = 13 \text{ V}$, $T_J = -40 \text{ to } 125 \text{ }^\circ\text{C}$		5	10	μA
eN	Output noise voltage	$B_p = 10 \text{ Hz to } 100 \text{ kHz}$, $I_O = 100 \text{ mA}$ (<i>Note 1</i>)		180		μV_{RMS}

- Note:*
- 1 Guaranteed by design.
 - 2 Dropout voltage is defined as the input-to-output differential when the output voltage drops to 99% of its nominal value with $V_O + 1 \text{ V}$ applied to V_I .
 - 3 Reference voltage is measured between output and GND pins, with ADJ PIN tied to V_O .
 - 4 In order to avoid any output voltage rise within the whole operating temperature range, due to output leakage current, a minimum load current of 2 mA is required.

$I_O = 10 \text{ mA}$, (*Note 4*) $T_J = 25 \text{ }^\circ\text{C}$, $V_I = 10 \text{ V}$, $V_{INH} = 2 \text{ V}$, $C_I = 330 \text{ nF}$, $C_O = 10 \text{ } \mu\text{F}$, unless otherwise specified)

Table 10. Electrical characteristics of LD29080#80

Symbol	Parameter	Test conditions	Min.	Typ.	Max.	Unit
V_I	Operating input voltage	$I_O = 10 \text{ mA to } 800 \text{ mA}$			13	V
V_O	Output voltage	$I_O = 10 \text{ mA to } 800 \text{ mA}$, $V_I = 9 \text{ to } 13 \text{ V}$ $T_J = -40 \text{ to } 125 \text{ }^\circ\text{C}$	7.92	8	8.08	V
			7.80		8.20	
ΔV_O	Load regulation	$I_O = 10 \text{ mA to } 800 \text{ mA}$		0.2	1.0	%
ΔV_O	Line regulation	$V_I = 9 \text{ to } 13 \text{ V}$		0.06	0.5	%
SVR	Supply voltage rejection	$f = 120 \text{ Hz}$, $V_I = 10 \pm 1 \text{ V}$, $I_O = 400 \text{ mA}$ (<i>Note 1</i>)	45	59		dB
V_{DROPP}	Dropout voltage	$I_O = 150 \text{ mA}$, $T_J = -40 \text{ to } 125 \text{ }^\circ\text{C}$ (<i>Note 2</i>)		0.1		V
		$I_O = 400 \text{ mA}$, $T_J = -40 \text{ to } 125 \text{ }^\circ\text{C}$ (<i>Note 2</i>)		0.2		
		$I_O = 800 \text{ mA}$, $T_J = -40 \text{ to } 125 \text{ }^\circ\text{C}$ (<i>Note 2</i>)		0.4	0.7	
I_q	Quiescent current	$I_O = 10 \text{ mA}$, $T_J = -40 \text{ to } 125 \text{ }^\circ\text{C}$		2	5	mA
		$I_O = 400 \text{ mA}$, $T_J = -40 \text{ to } 125 \text{ }^\circ\text{C}$		8	20	
		$I_O = 800 \text{ mA}$, $T_J = -40 \text{ to } 125 \text{ }^\circ\text{C}$		14	35	
		$V_I = 13 \text{ V}$, $V_{INH} = \text{GND}$, $T_J = -40 \text{ to } 125 \text{ }^\circ\text{C}$		130	180	μA
I_{sc}	Short circuit current	$R_L = 0$		1.2		A
V_{IL}	Control input logic low	OFF MODE, $T_J = -40 \text{ to } 125 \text{ }^\circ\text{C}$			0.8	V
V_{IH}	Control input logic high	ON MODE, $T_J = -40 \text{ to } 125 \text{ }^\circ\text{C}$	2			V
I_{INH}	Control input current	$V_{INH} = 13 \text{ V}$, $T_J = -40 \text{ to } 125 \text{ }^\circ\text{C}$		5	10	μA
eN	Output noise voltage	$B_p = 10 \text{ Hz to } 100 \text{ kHz}$, $I_O = 100 \text{ mA}$ (<i>Note 1</i>)		320		μV_{RMS}

- Note:*
- 1 Guaranteed by design.
 - 2 Dropout voltage is defined as the input-to-output differential when the output voltage drops to 99% of its nominal value with $V_O + 1 \text{ V}$ applied to V_I .
 - 3 Reference voltage is measured between output and GND pins, with ADJ PIN tied to V_O .
 - 4 In order to avoid any output voltage rise within the whole operating temperature range, due to output leakage current, a minimum load current of 2 mA is required.

$I_O = 10 \text{ mA}$, (*Note 4*) $T_J = 25 \text{ }^\circ\text{C}$, $V_I = 11 \text{ V}$, $V_{INH} = 2 \text{ V}$, $C_I = 330 \text{ nF}$, $C_O = 10 \text{ } \mu\text{F}$, unless otherwise specified.

Table 11. Electrical characteristics of LD29080#90

Symbol	Parameter	Test conditions	Min.	Typ.	Max.	Unit
V_I	Operating input voltage	$I_O = 10 \text{ mA}$ to 800 mA			13	V
V_O	Output voltage	$I_O = 10 \text{ mA}$ to 800 mA , $V_I = 9$ to 13 V $T_J = -40$ to $125 \text{ }^\circ\text{C}$	8.91	9	9.09	V
			8.775		9.225	
ΔV_O	Load regulation	$I_O = 10 \text{ mA}$ to 800 mA		0.2	1.0	%
ΔV_O	Line regulation	$V_I = 10$ to 13 V		0.06	0.5	%
SVR	Supply voltage rejection	$f = 120 \text{ Hz}$, $V_I = 11 \pm 1 \text{ V}$, $I_O = 400 \text{ mA}$ (<i>Note 1</i>)	43	57		dB
V_{DROPP}	Dropout voltage	$I_O = 150 \text{ mA}$, $T_J = -40$ to $125 \text{ }^\circ\text{C}$ (<i>Note 2</i>)		0.1		V
		$I_O = 400 \text{ mA}$, $T_J = -40$ to $125 \text{ }^\circ\text{C}$ (<i>Note 2</i>)		0.2		
		$I_O = 800 \text{ mA}$, $T_J = -40$ to $125 \text{ }^\circ\text{C}$ (<i>Note 2</i>)		0.4	0.7	
I_q	Quiescent current	$I_O = 10 \text{ mA}$, $T_J = -40$ to $125 \text{ }^\circ\text{C}$		2	5	mA
		$I_O = 400 \text{ mA}$, $T_J = -40$ to $125 \text{ }^\circ\text{C}$		8	20	
		$I_O = 800 \text{ mA}$, $T_J = -40$ to $125 \text{ }^\circ\text{C}$		14	35	
		$V_I = 13 \text{ V}$, $V_{INH} = \text{GND}$, $T_J = -40$ to $125 \text{ }^\circ\text{C}$		130	180	μA
I_{sc}	Short circuit current	$R_L = 0$		1.2		A
V_{IL}	Control input logic low	OFF MODE, $T_J = -40$ to $125 \text{ }^\circ\text{C}$			0.8	V
V_{IH}	Control input logic high	ON MODE, $T_J = -40$ to $125 \text{ }^\circ\text{C}$	2			V
I_{INH}	Control input current	$V_{INH} = 13 \text{ V}$, $T_J = -40$ to $125 \text{ }^\circ\text{C}$		5	10	μA
eN	Output noise voltage	$B_p = 10 \text{ Hz}$ to 100 kHz , $I_O = 100 \text{ mA}$ (<i>Note 1</i>)		330		μV_{RMS}

- Note:*
- 1 Guaranteed by design.
 - 2 Dropout voltage is defined as the input-to-output differential when the output voltage drops to 99% of its nominal value with $V_O + 1 \text{ V}$ applied to V_I .
 - 3 Reference voltage is measured between output and GND pins, with ADJ PIN tied to V_O .
 - 4 In order to avoid any output voltage rise within the whole operating temperature range, due to output leakage current, a minimum load current of 2 mA is required.

$I_O = 10$ mA, (*Note 4*) $T_J = 25$ °C, $V_I = 10$ V, $V_{INH} = 2$ V, $C_I = 330$ nF, $C_O = 10$ μ F, unless otherwise specified.

Table 12. Electrical characteristics of LD29080#ADJ

Symbol	Parameter	Test conditions	Min.	Typ.	Max.	Unit
V_I	Operating input voltage	$I_O = 10$ mA to 800 mA	2.5		13	V
ΔV_O	Load regulation	$I_O = 10$ mA to 800 mA		0.2	1.0	%
ΔV_O	Line regulation	$V_I = 2.5$ to 13 V, $I_O = 10$ mA		0.06	0.5	%
V_{REF}	Reference voltage	$I_O = 10$ mA to 800 mA, $V_I = 2.5$ to 6.73 V $T_J = -40$ to 125 °C (<i>Note 3</i>)	1.2177	1.23	1.2423	V
			1.1993		1.2607	
SVR	Supply voltage rejection	$f = 120$ Hz, $V_I = 3.23 \pm 1$ V, $I_O = 400$ mA (<i>Note 1</i>)	45	75		dB
I_q	Quiescent current	$I_O = 10$ mA, $T_J = -40$ to 125 °C		2	5	mA
		$I_O = 400$ mA, $T_J = -40$ to 125 °C		8	20	
		$I_O = 800$ mA, $T_J = -40$ to 125 °C		14	35	
		$V_I = 13$ V, $V_{INH} = GND$, $T_J = -40$ to 125 °C		130	180	μ A
I_{ADJ}	Adjust pin current	$T_J = -40$ to 125 °C			1	μ A
I_{sc}	Short circuit current	$R_L = 0$		1.2		A
V_{IL}	Control input logic low	OFF MODE, $T_J = -40$ to 125 °C			0.8	V
V_{IH}	Control input logic high	ON MODE, $T_J = -40$ to 125 °C	2			V
I_{INH}	Control input current	$V_{INH} = 13$ V, $T_J = -40$ to 125 °C		5	10	μ A
eN	Output noise voltage	$B_P = 10$ Hz to 100 kHz, $I_O = 100$ mA (<i>Note 1</i>)		50		μ V _{RMS}

Note: 1 Guaranteed by design.

2 Dropout voltage is defined as the input-to-output differential when the output voltage drops to 99% of its nominal value with $V_O + 1$ V applied to V_I .

3 Reference voltage is measured between output and GND pins, with ADJ PIN tied to V_O .

4 In order to avoid any output voltage rise within the whole operating temperature range, due to output leakage current, a minimum load current of 2 mA is required.

5 Typical characteristics

Figure 5. Output voltage vs. temperature

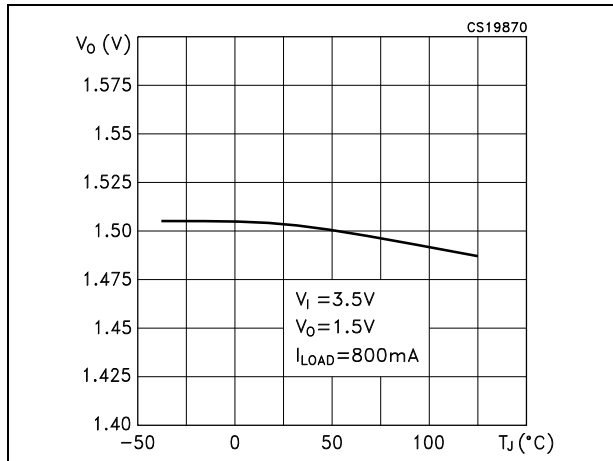

Figure 6. Reference voltage vs. temperature

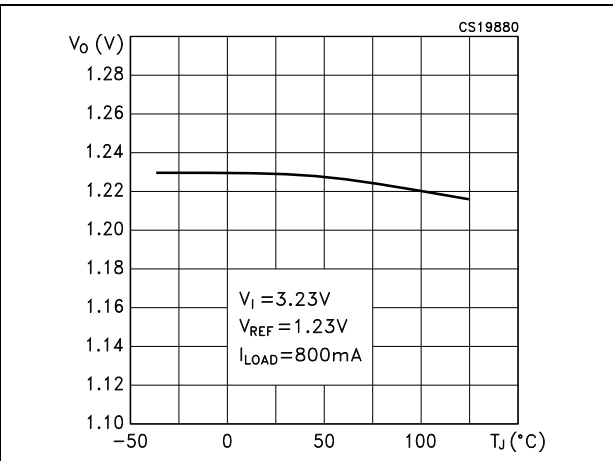

Figure 7. Dropout voltage vs. temperature

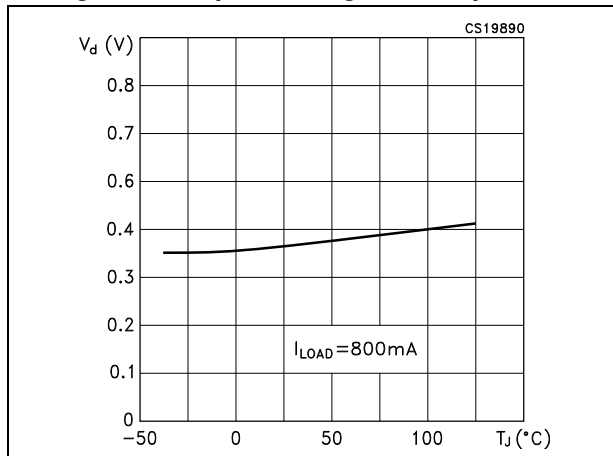

Figure 8. Dropout voltage vs. output current

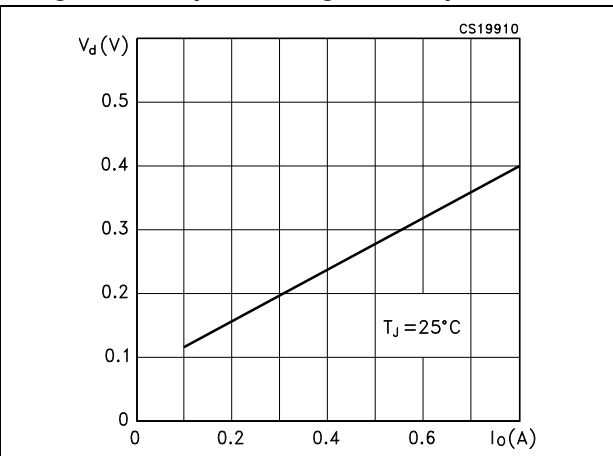

Figure 9. Quiescent current vs. output current

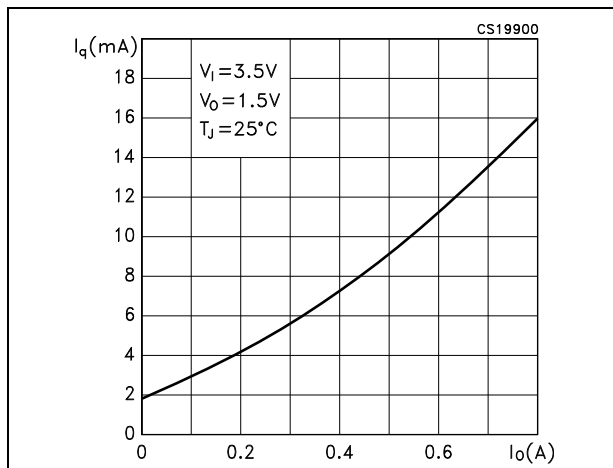

Figure 10. Quiescent current vs. temperature ($I_o = 10$ mA)

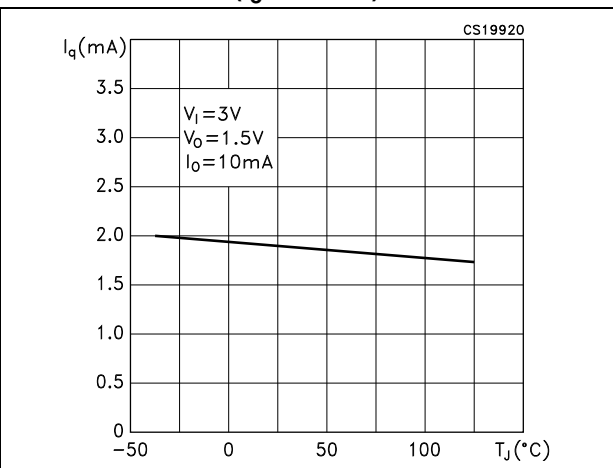

Figure 11. Quiescent current vs. supply voltage

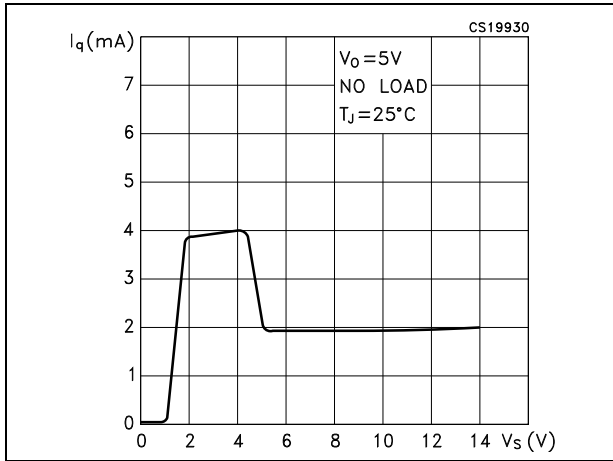

Figure 12. Quiescent current vs. temperature ($I_o = 800\text{ mA}$)

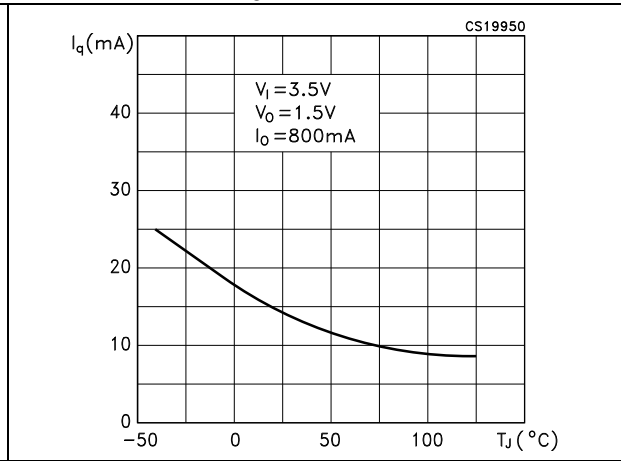

Figure 13. Short circuit current vs. temperature

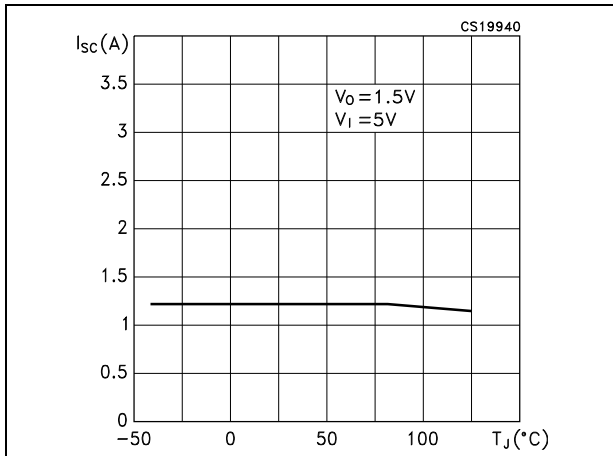

Figure 14. Adjust pin current vs. temperature

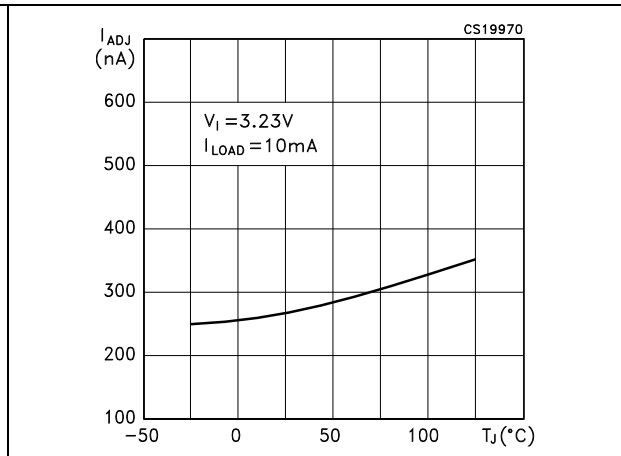

Figure 15. Supply voltage rejection vs. temperature

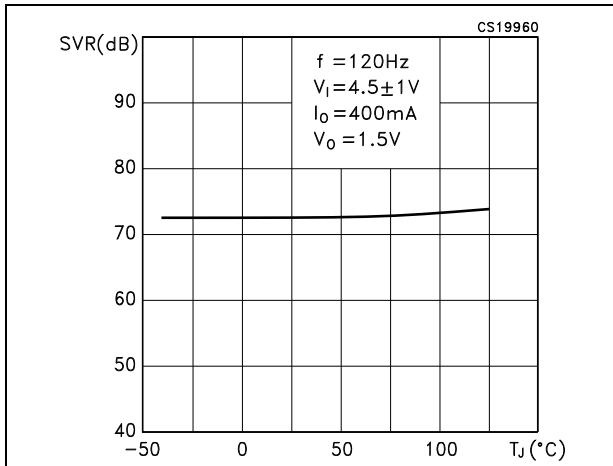

Figure 16. Output voltage vs. input voltage

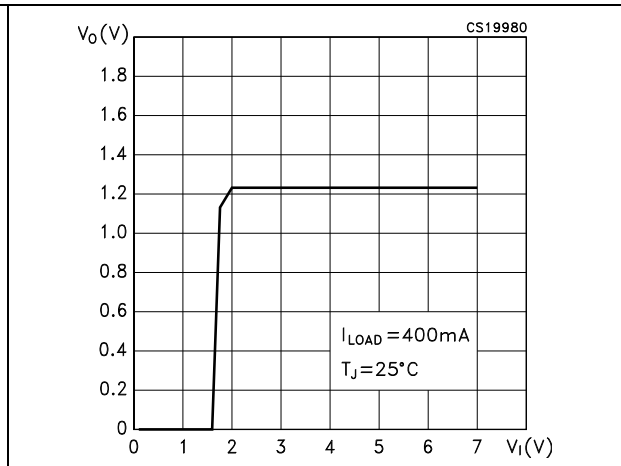

Figure 17. Stability vs. C_O

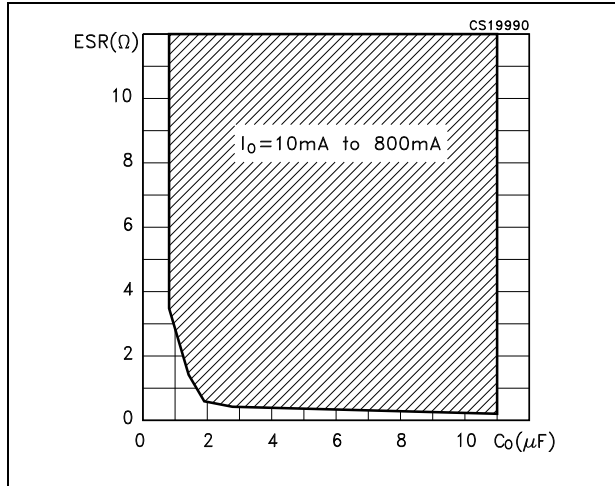

Figure 18. Line transient

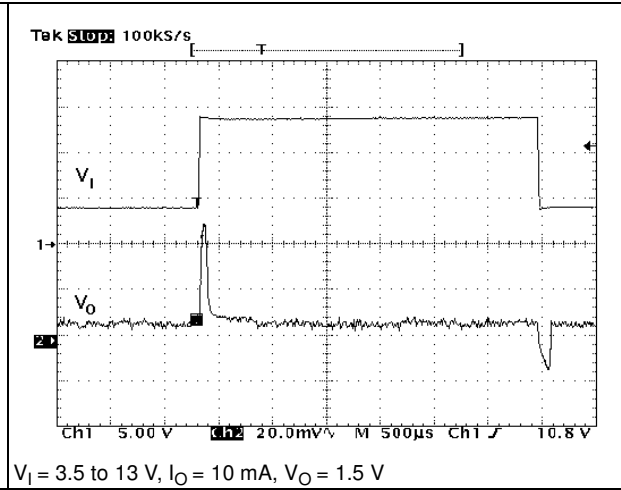
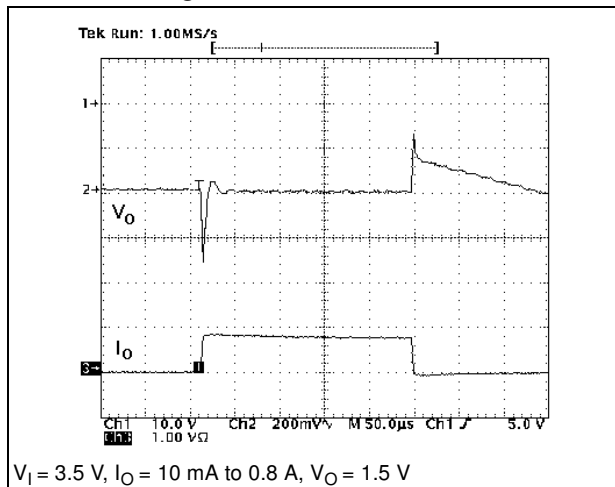

Figure 19. Load transient



6 Package mechanical data

In order to meet environmental requirements, ST offers these devices in different grades of ECOPACK packages, depending on their level of environmental compliance. ECOPACK specifications, grade definitions and product status are available at: www.st.com. ECOPACK is an ST trademark.

Table 13. PPAK mechanical data

Dim.	mm		
	Min.	Typ.	Max.
A	2.2		2.4
A1	0.9		1.1
A2	0.03		0.23
B	0.4		0.6
B2	5.2		5.4
C	0.45		0.6
C2	0.48		0.6
D	6		6.2
D1		5.1	
E	6.4		6.6
E1		4.7	
e		1.27	
G	4.9		5.25
G1	2.38		2.7
H	9.35		10.1
L2		0.8	1
L4	0.6		1
L5	1		
L6		2.8	
R		0.20	
V2	0°		8°

Figure 20. PPAK drawing

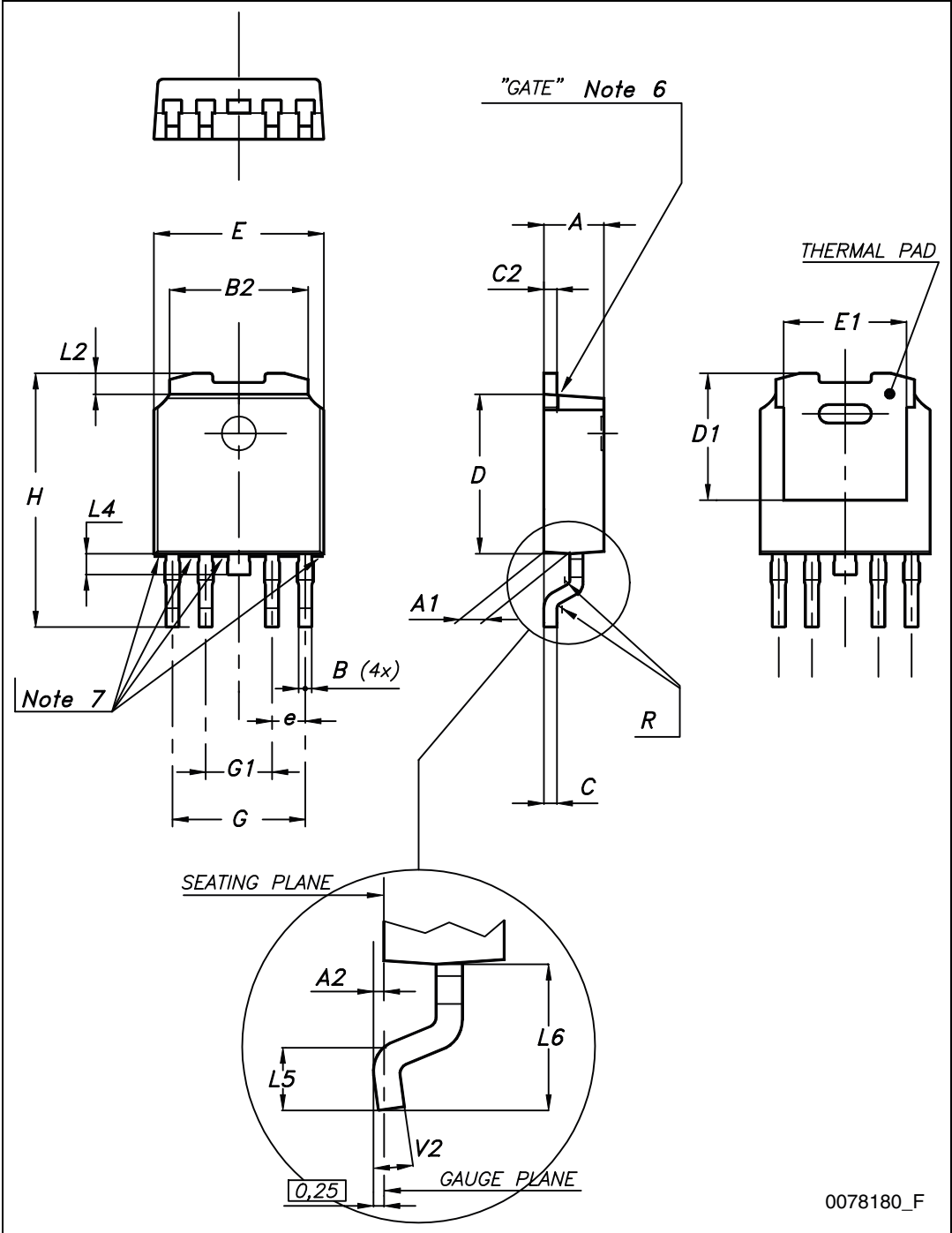
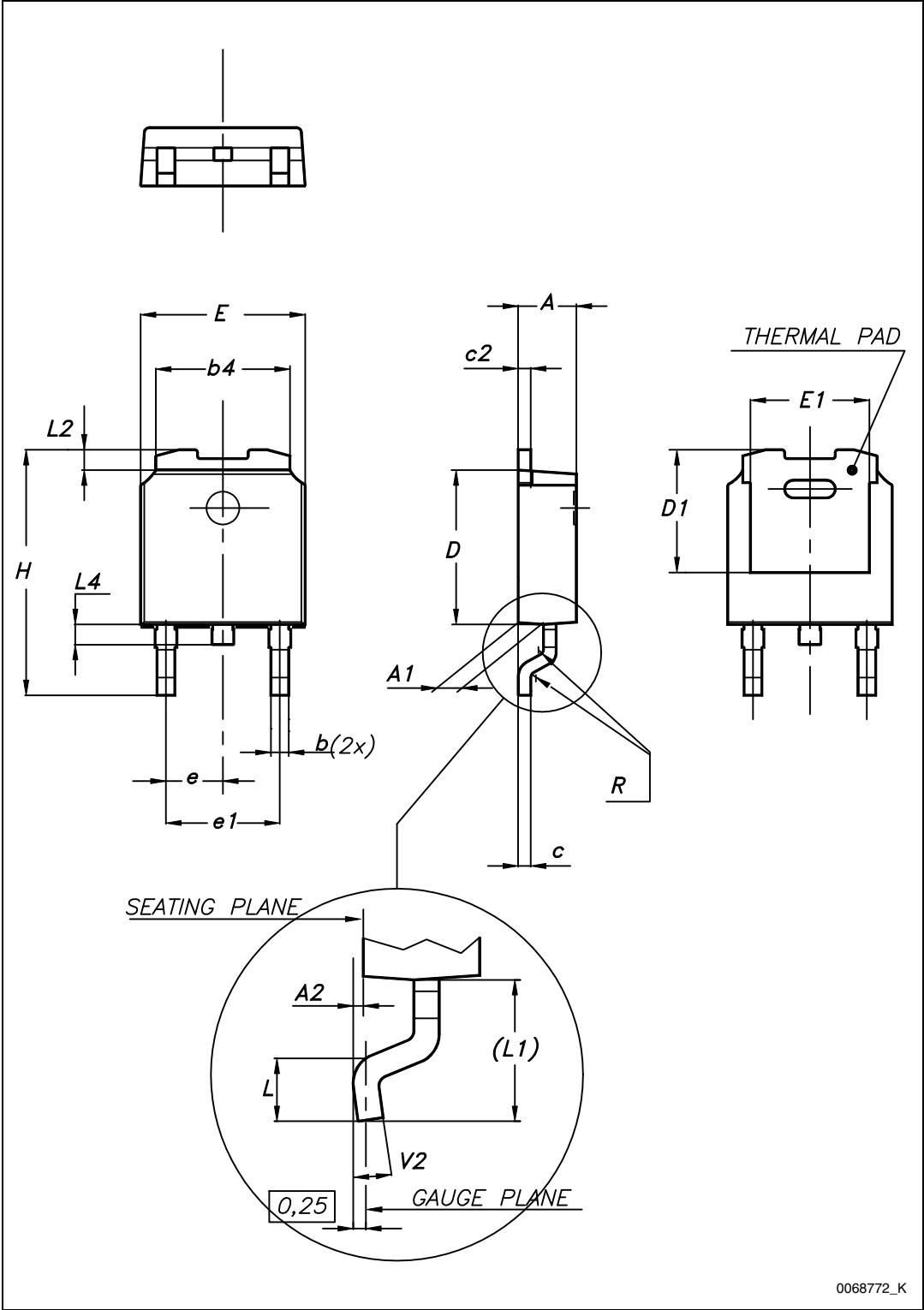

Table 14. DPAK mechanical data

Dim.	mm		
	Min.	Typ.	Max.
A	2.20		2.40
A1	0.90		1.10
A2	0.03		0.23
b	0.64		0.90
b4	5.20		5.40
c	0.45		0.60
c2	0.48		0.60
D	6.00		6.20
D1		5.10	
E	6.40		6.60
E1		4.70	
e		2.28	
e1	4.40		4.60
H	9.35		10.10
L	1.00		1.50
(L1)		2.80	
L2		0.80	
L4	0.60		1.00
R		0.20	
V2	0°		8°

Figure 21. DPAK drawing



0068772_K



Figure 22. DPAK footprint (a)

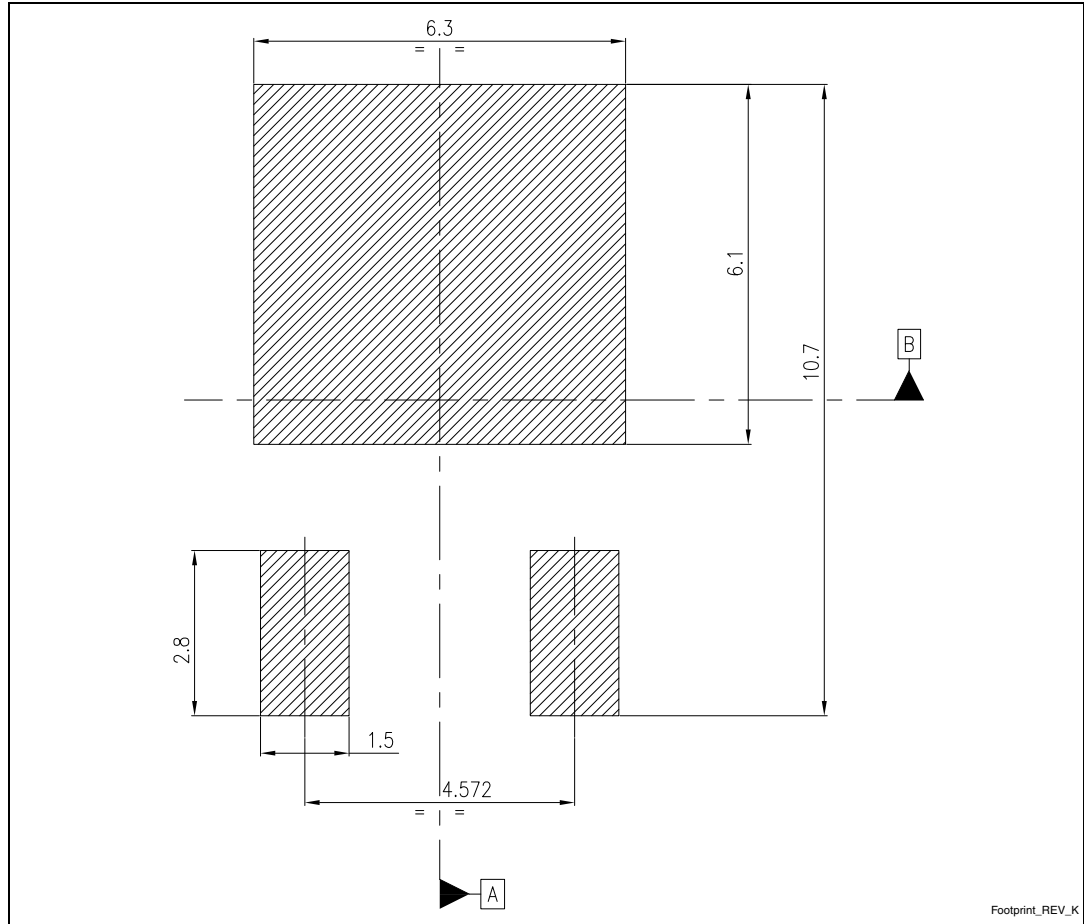

a. All dimensions are in millimeters

Table 15. SOT-223 mechanical data

Dim.	mm		
	Min.	Typ.	Max.
A			1.80
A1	0.02		0.1
B	0.60	0.70	0.85
B1	2.90	3.00	3.15
c	0.24	0.26	0.35
D	6.30	6.50	6.70
e		2.30	
e1		4.60	
E	3.30	3.50	3.70
H	6.70	7.00	7.30
V			10°

Figure 23. SOT-223 mechanical data drawing

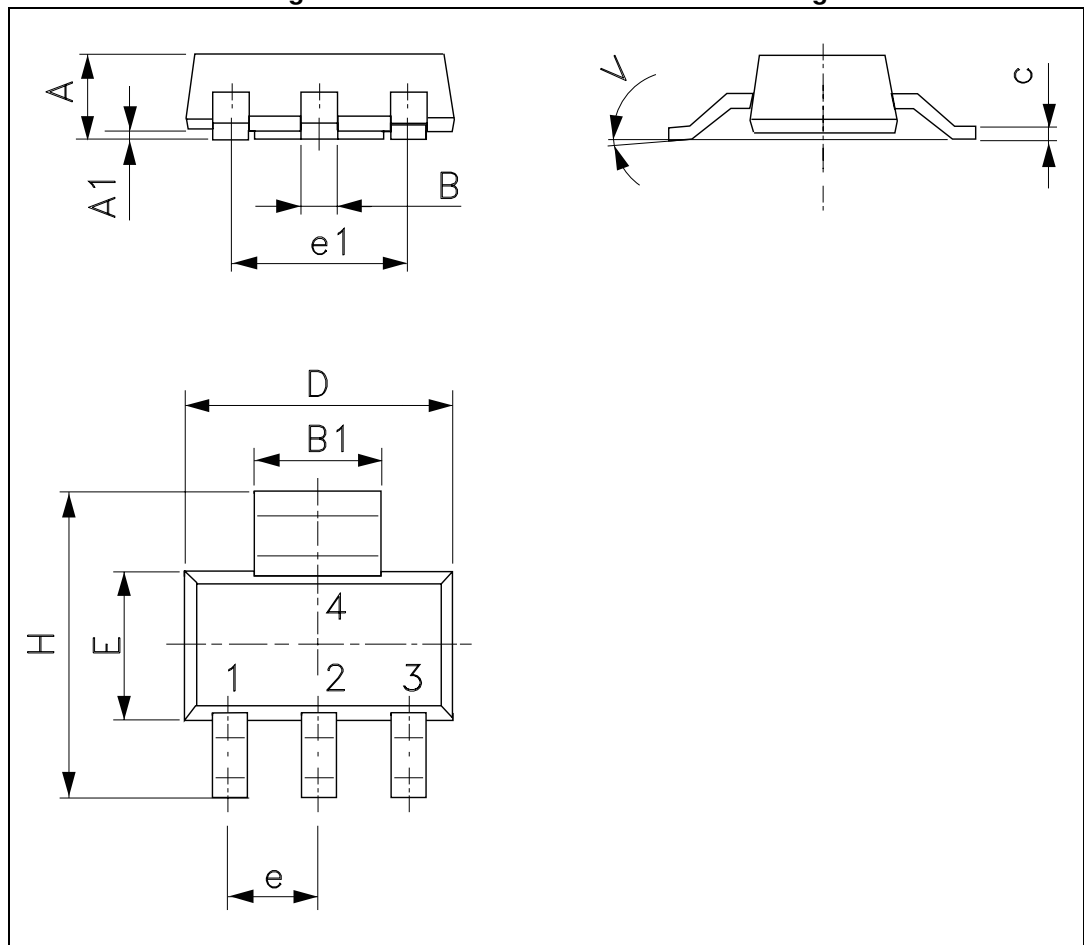

7 Packaging mechanical data

Table 16. PPAK and DPAK tape and reel mechanical data

Tape			Reel		
Dim.	mm		Dim.	mm	
	Min.	Max.		Min.	Max.
A0	6.8	7	A		330
B0	10.4	10.6	B	1.5	
B1		12.1	C	12.8	13.2
D	1.5	1.6	D	20.2	
D1	1.5		G	16.4	18.4
E	1.65	1.85	N	50	
F	7.4	7.6	T		22.4
K0	2.55	2.75			
P0	3.9	4.1	Base qty.		2500
P1	7.9	8.1	Bulk qty.		2500
P2	1.9	2.1			
R	40				
T	0.25	0.35			
W	15.7	16.3			

Figure 24. Tape for PPAK and DPAK

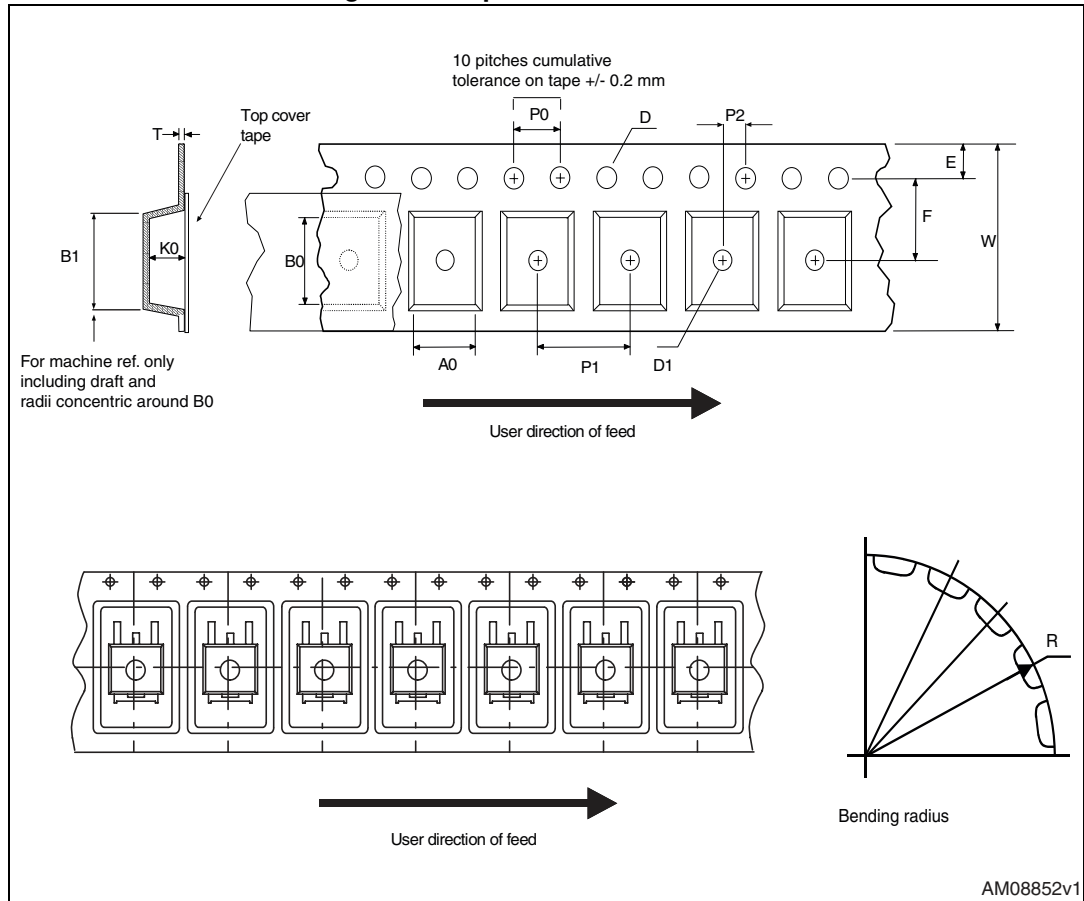
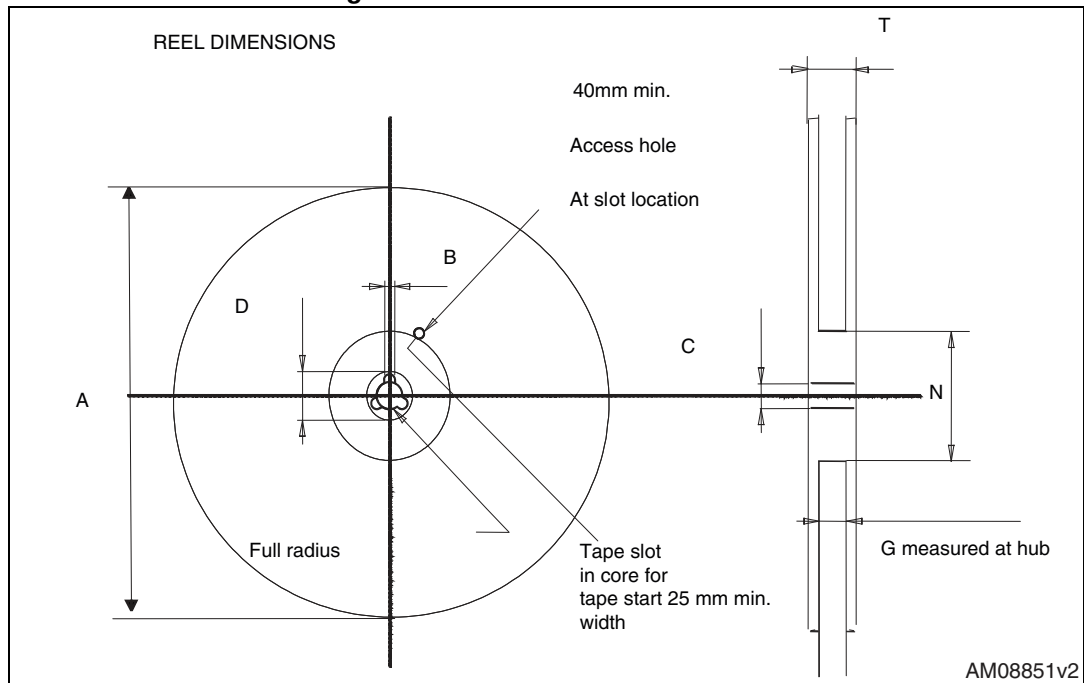

Figure 25. Reel for PPAK and DPAK



8 Revision history

Table 17. Document revision history

Date	Revision	Changes
15-Oct-2004	1	First release.
20-Oct-2005	2	Order codes updated.
14-May-2007	3	Order codes updated.
26-Jan-2009	4	Modified: eN value in Table 9 on page 10.
22-Feb-2011	5	Added: new order code Table 1 on page 1 and mechanical data.
12-Jan-2012	6	Modified: R_{thJA} and R_{thJC} value for SOT223 Table 4 on page 5.
08-May-2012	7	Modified: pin connections for PPAK, DPAK and SOT223 Figure 3 on page 4.
22-Nov-2013	8	Part number LD29080xx changed to LD29080. Updated the Description in cover page, Table 1: Device summary. Updated Section 5: Typical characteristics and Section 6: Package mechanical data. Added Section 7: Packaging mechanical data. Minor text changes.
13-Feb-2020	9	Updated Figure 23: SOT-223 mechanical data drawing .

IMPORTANT NOTICE – PLEASE READ CAREFULLY

STMicroelectronics NV and its subsidiaries (“ST”) reserve the right to make changes, corrections, enhancements, modifications, and improvements to ST products and/or to this document at any time without notice. Purchasers should obtain the latest relevant information on ST products before placing orders. ST products are sold pursuant to ST’s terms and conditions of sale in place at the time of order acknowledgement.

Purchasers are solely responsible for the choice, selection, and use of ST products and ST assumes no liability for application assistance or the design of Purchasers’ products.

No license, express or implied, to any intellectual property right is granted by ST herein.

Resale of ST products with provisions different from the information set forth herein shall void any warranty granted by ST for such product.

ST and the ST logo are trademarks of ST. For additional information about ST trademarks, please refer to www.st.com/trademarks. All other product or service names are the property of their respective owners.

Information in this document supersedes and replaces information previously supplied in any prior versions of this document.

© 2020 STMicroelectronics – All rights reserved

X-ON Electronics

Largest Supplier of Electrical and Electronic Components

Click to view similar products for [LDO Voltage Regulators](#) category:

Click to view products by [STMicroelectronics](#) manufacturer:

Other Similar products are found below :

[M38D29FFHP#U1](#) [702103A](#) [717726C](#) [742457H](#) [MP20051DN-LF-Z](#) [R5F111PGGFB#30](#) [AP7363-SP-13](#) [NCP103AMX285TCG](#)
[NCV8664CST33T3G](#) [NCV8752AMX28TCG](#) [L9454](#) [AP7362-HA-7](#) [LX13043CLD](#) [TCR3DF185,LM\(CT](#) [TCR3DF24,LM\(CT](#)
[TCR3DF285,LM\(CT](#) [TCR3DF31,LM\(CT](#) [TCR3DF45,LM\(CT](#) [TLF4949EJ](#) [MP2013GQ-33-Z](#) [L9708](#) [L970813TR](#) [030014BB](#) [059985X](#)
[NCP121AMX173TCG](#) [NCP4687DH15T1G](#) [701326R](#) [702087BB](#) [755078E](#) [TCR2EN28,LF\(S](#) [LM1117DT-1.8/NO](#) [LT1086CM#TRPBF](#)
[AZ1085S2-1.5TRE1](#) [MAX15101EWL+T](#) [NCV8170AXV250T2G](#) [TCR3DF27,LM\(CT](#) [TCR3DF19,LM\(CT](#) [TCR3DF125,LM\(CT](#)
[TCR2EN18,LF\(S](#) [MAX15103EWL+T](#) [TS2937CZ-5.0 C0](#) [MAX8878EUK30-T](#) [MAX663CPA](#) [NCV4269CPD50R2G](#) [NCV8716MT30TBG](#)
[AZ1117IH-1.2TRG1](#) [MP2013GQ-P](#) [AP2112R5A-3.3TRG1](#) [AP7315-25W5-7](#) [MAX15102EWL+T](#)