

## 150 mA low noise high PSRR linear voltage regulator

Datasheet - production data

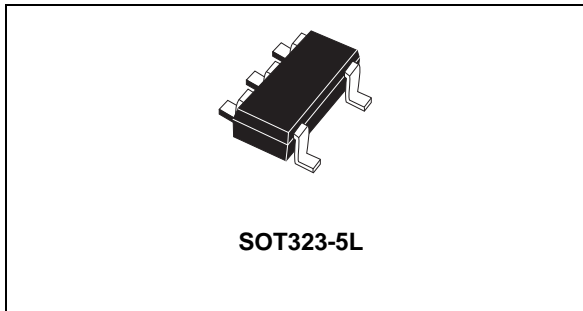

### Description

The LD59015 provides 150 mA maximum current with an input voltage range from 2.4 V to 5.5 V, and a typical dropout voltage of 150 mV. It is stable with ceramic capacitors. High PSRR, low quiescent current and low noise features make it suitable for low power battery-powered applications. Power supply rejection is 80 dB at low frequency and starts to roll off at 10 kHz. The enable logic control function puts the LD59015 in shutdown mode, allowing a total current consumption lower than 1  $\mu$ A. The device also includes short-circuit constant current limiting and thermal protection. Typical applications are mobile phones, personal digital assistants (PDAs), cordless phones and similar battery-powered systems.

### Features

- Input voltage from 2.4 to 5.5 V
- Very low quiescent current (31  $\mu$ A typ. at no-load, 75  $\mu$ A typ. at 150 mA load, 1  $\mu$ A max. in OFF mode)
- Very low noise (20  $\mu$ V<sub>RMS</sub> at  $V_{OUT} = 1.5$  V)
- Output voltage tolerance:  $\pm 1.8\%$  at 25  $^{\circ}$ C
- 150 mA guaranteed output current
- Wide range of output voltages available on request: 1.2 V to 3.3 V in 100 mV steps
- Logic-controlled electronic shutdown
- Compatible with ceramic capacitors
- Very high PSRR (80 dB @ 100 Hz, 76 @ 10 kHz, 54 @ 100 kHz)
- Internal current and thermal limit
- Package: SOT323-5L
- Temperature range: -40  $^{\circ}$ C to 125  $^{\circ}$ C

Table 1. Device summary

Order code	Output voltages
LD59015C12R	1.2 V
LD59015C15R	1.5 V
LD59015C18R	1.8 V
LD59015C25R	2.5 V
LD59015C30R	3.0 V
LD59015C33R	3.3 V

# Contents

<b>1</b>	<b>Block diagram</b> .....	<b>3</b>
<b>2</b>	<b>Pin configuration</b> .....	<b>4</b>
<b>3</b>	<b>Typical application</b> .....	<b>5</b>
<b>4</b>	<b>Maximum ratings</b> .....	<b>6</b>
<b>5</b>	<b>Electrical characteristics</b> .....	<b>7</b>
<b>6</b>	<b>Typical performance characteristics</b> .....	<b>9</b>
<b>7</b>	<b>Package information</b> .....	<b>13</b>
	7.1 SOT323-5L package information .....	13
	7.2 SOT323-5L packing information .....	15
<b>8</b>	<b>Revision history</b> .....	<b>17</b>



# 1 Block diagram

Figure 1. LD59015 block diagram

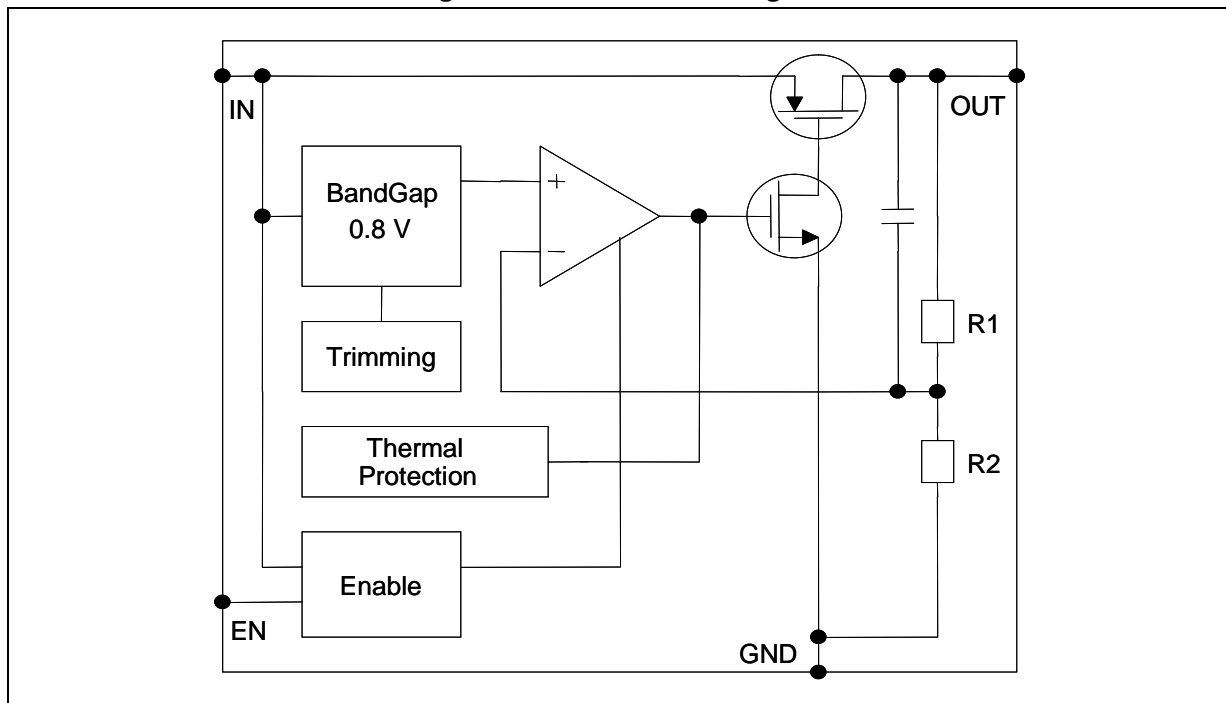

## 2 Pin configuration

Figure 2. Pin connection (top view)

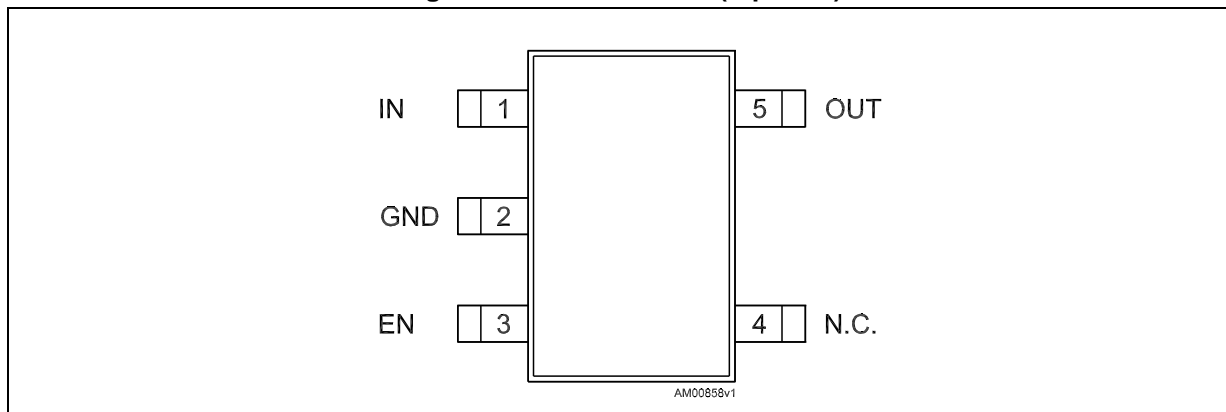
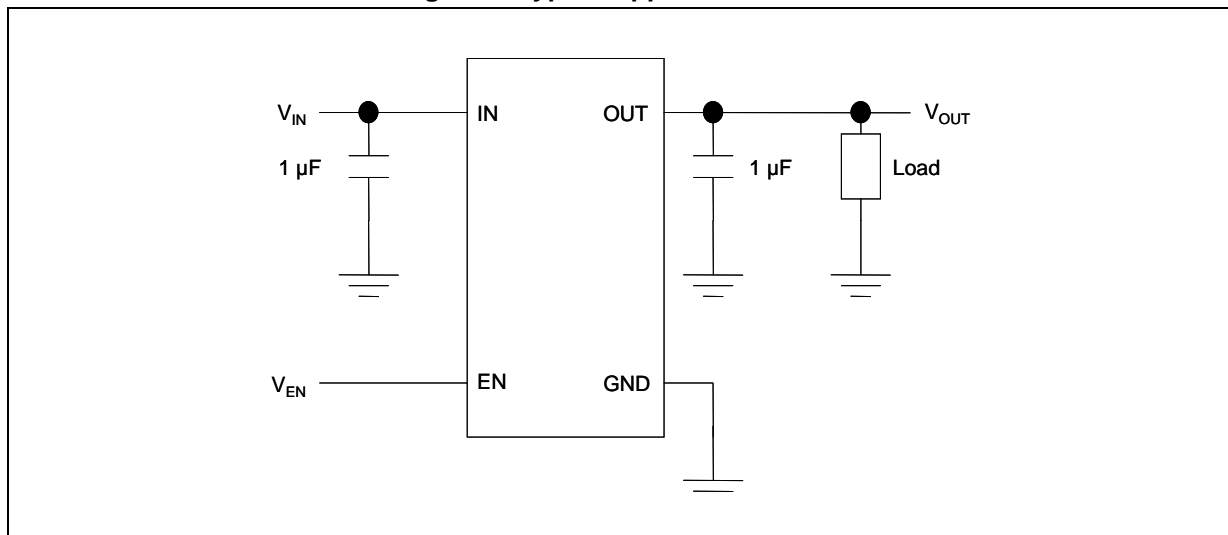

Table 2. Pin description

Pin	Symbol	Function
1	IN	Input voltage
2	GND	Ground
3	EN	Enable input Set $V_{EN} > 0.9$ to turn on the device Set $V_{EN} < 0.4$ to turn off the device
4	N.C.	Not connected
5	OUT	Output voltage

### 3 Typical application

Figure 3. Typical application circuit



## 4 Maximum ratings

**Table 3. Absolute maximum ratings**

Symbol	Parameter	Value	Unit
$V_{IN}$	DC input voltage	- 0.3 to 7	V
$V_{OUT}$	DC output voltage	- 0.3 to $V_I + 0.3$ (max. 7)	V
$V_{EN}$	Enable input voltage	- 0.3 to $V_I + 0.3$ (max. 7)	V
$I_{OUT}$	Output current	Internally limited	mA
$P_D$	Power dissipation	Internally limited	mW
ESD	Human body model	$\pm 3$	kV
	Machine model	$\pm 300$	V
$T_{STG}$	Storage temperature range	-65 to 150	°C
$T_{OP}$	Operating junction temperature range	-40 to 125	°C

*Note:* Absolute maximum ratings are those values beyond which damage to the device may occur. Functional operation under these conditions is not implied. All values are referred to GND.

**Table 4. Thermal data**

Symbol	Parameter	Value	Unit
$R_{thJA}$	Thermal resistance junction-ambient	645.69	°C/W
$R_{thJC}$	Thermal resistance junction-case	116	°C/W

## 5 Electrical characteristics

$T_J = 25\text{ °C}$ ,  $V_{IN} = V_{OUT(NOM)} + 1\text{ V}$ ,  $C_{IN} = C_{OUT} = 1\text{ }\mu\text{F}$ ,  $I_{OUT} = 1\text{ mA}$ ,  $V_{EN} = V_{IN}$ , unless otherwise specified.

**Table 5. Electrical characteristics (1)**

Symbol	Parameter	Test conditions	Min.	Typ.	Max.	Unit
$V_{IN}$	Operating input voltage		2.4		5.5	V
$V_{UVLO}$	Turn-on threshold			2.0	2.15	
	Turn-off threshold		1.90	1.95		
$V_{OUT}$	$V_{OUT}$ accuracy	$I_{OUT} = 1\text{ mA}$ , $-40\text{ °C} < T_J < 125\text{ °C}$	-1.8		1.8	%
$\Delta V_{OUT}$	Static line regulation	$V_{OUT} + 1\text{ V} \leq V_{IN} \leq 5.5\text{ V}$ , $I_{OUT} = 1\text{ mA}$		0.001		%/V
$\Delta V_{OUT}$	Static load regulation	$I_{OUT} = 1\text{ mA}$ to $150\text{ mA}$		0.001		%/mA
$V_{DROP}$	Dropout voltage (2)	$I_{OUT} = 150\text{ mA}$ , $V_{OUT} > 2.2\text{ V}$ $-40\text{ °C} < T_J < 125\text{ °C}$		150	210	mV
$e_N$	Output noise voltage	10 Hz to 100 kHz, $I_{OUT} = 10\text{ mA}$ , $V_{OUT} = 1.5\text{ V}$		20		$\mu\text{V}_{RMS}$ $/V_{OUT}$
SVR	Supply voltage rejection $V_{OUT} = 1.5\text{ V}$	$V_{IN} = V_{OUTNOM} + 1\text{ V} \pm V_{RIPPLE}$ $V_{RIPPLE} = 0.5\text{ V}$ , frequency = 1 kHz $I_{OUT} = 1\text{ mA}$		76		dB
		$V_{IN} = V_{OUTNOM} + 1\text{ V} \pm V_{RIPPLE}$ $V_{RIPPLE} = 0.5\text{ V}$ , frequency = 10 kHz $I_{OUT} = 1\text{ mA}$		76		
		$V_{IN} = V_{OUTNOM} + 1\text{ V} \pm V_{RIPPLE}$ $V_{RIPPLE} = 0.5\text{ V}$ , frequency = 100 kHz $I_{OUT} = 1\text{ mA}$		54		
$I_Q$	Quiescent current	$I_{OUT} = 0\text{ mA}$		31		$\mu\text{A}$
		$I_{OUT} = 0\text{ mA}$ , $-40\text{ °C} < T_J < 125\text{ °C}$			60	
		$I_{OUT} = 0$ to $150\text{ mA}$		75		
		$I_{OUT} = 0$ to $150\text{ mA}$ $-40\text{ °C} < T_J < 125\text{ °C}$			110	
		$V_{IN}$ input current in OFF mode: $V_{EN} = \text{GND}$		0.001	1	
$I_{SC}$	Short-circuit current	$R_L = 0$	200			mA
$V_{EN}$	Enable input logic low	$V_{IN} = 2.4\text{ V}$ to $5.5\text{ V}$ , $-40\text{ °C} < T_J < 85\text{ °C}$			0.4	V
	Enable input logic high	$V_{IN} = 2.4\text{ V}$ to $5.5\text{ V}$ , $-40\text{ °C} < T_J < 85\text{ °C}$	0.9			V

Table 5. Electrical characteristics (continued)<sup>(1)</sup>

Symbol	Parameter	Test conditions	Min.	Typ.	Max.	Unit
$I_{EN}$	Enable pin input current	$V_{SHDN} = 5.5V$		0.1	100	nA
$T_{ON}$	Turn-on time <sup>(3)</sup>			200		$\mu s$
$T_{SHDN}$	Thermal shutdown			160		°C
	Hysteresis			20		
$C_{OUT}$	Output capacitor	Capacitance (see <a href="#">Section 6</a> )	1		4.7	$\mu F$

1. For  $V_{OUT(NOM)} < 1.3 V$ ,  $V_{IN} = 2.4 V$ .
2. Dropout voltage is the input-to-output voltage difference at which the output voltage is 100 mV below its nominal value. This specification does not apply to output voltages below 1.7 V.
3. Turn-on time is time measured between the enable input just exceeding  $V_{EN}$  high value and the output voltage just reaching 95% of its nominal value.

*Note:* All transient values are guaranteed by design, not tested in production.



## 6 Typical performance characteristics

$$C_{IN} = C_{OUT} = 1 \mu F$$

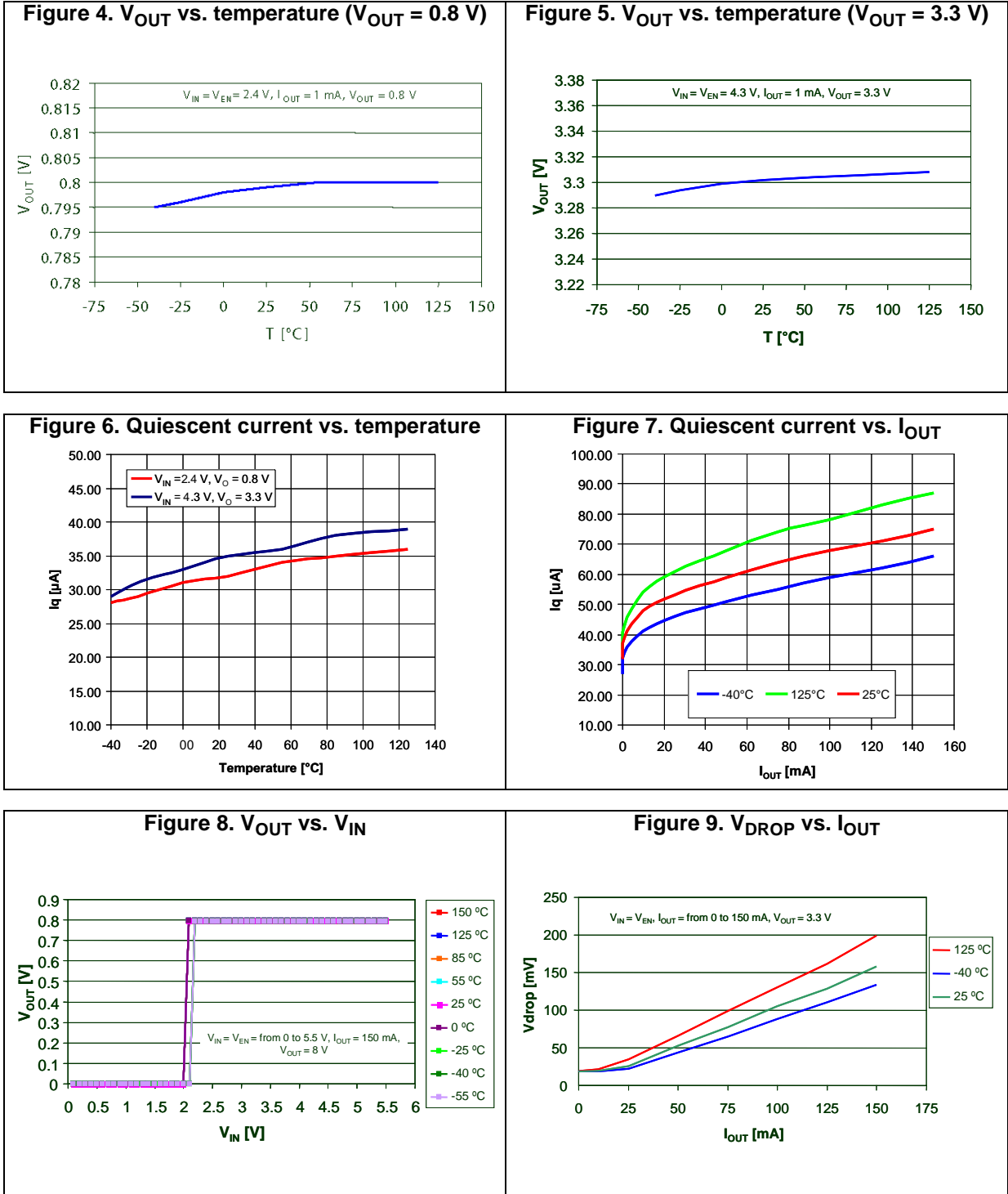

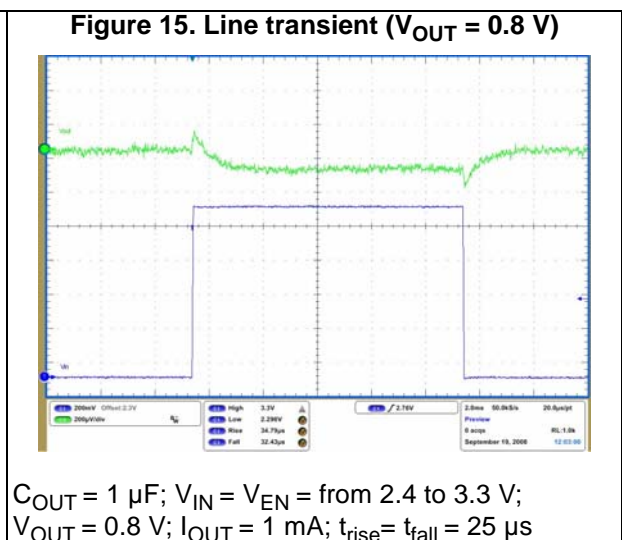
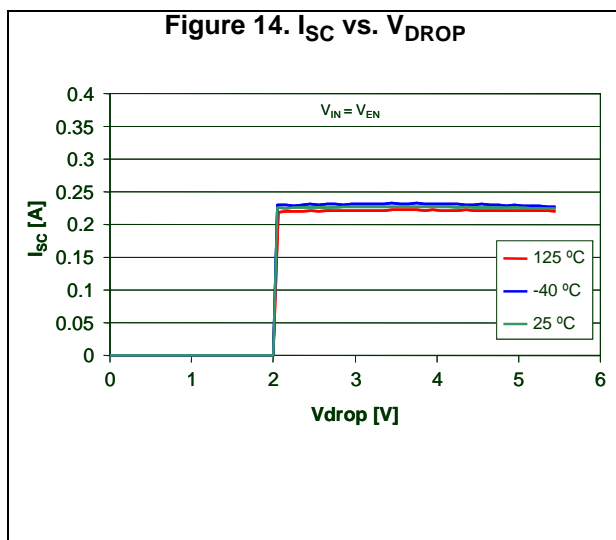
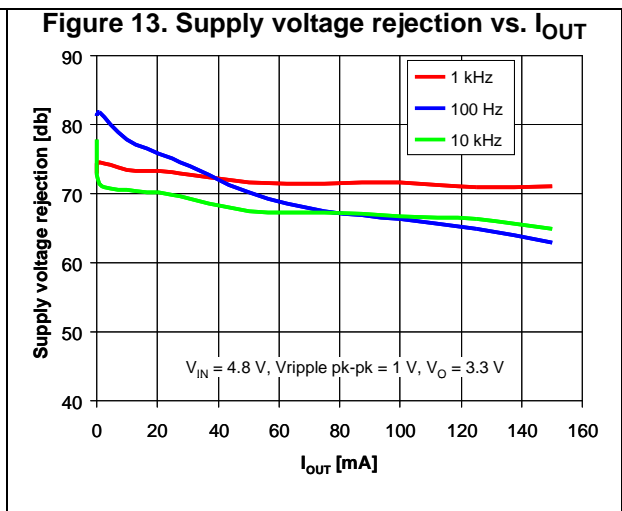
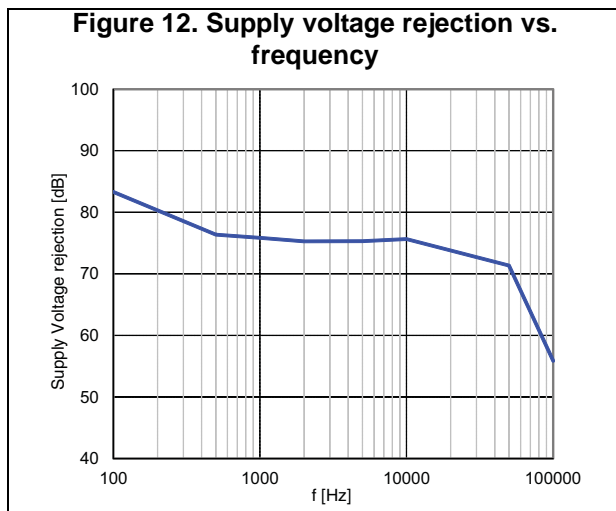
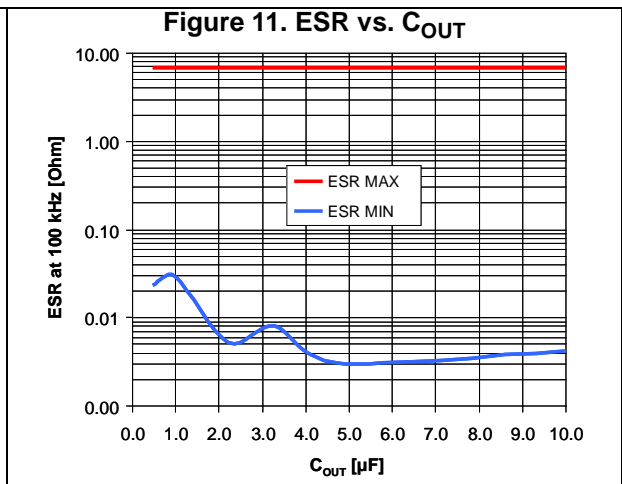
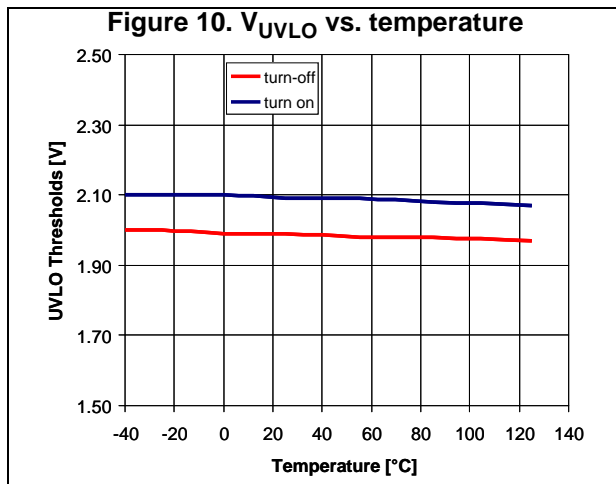
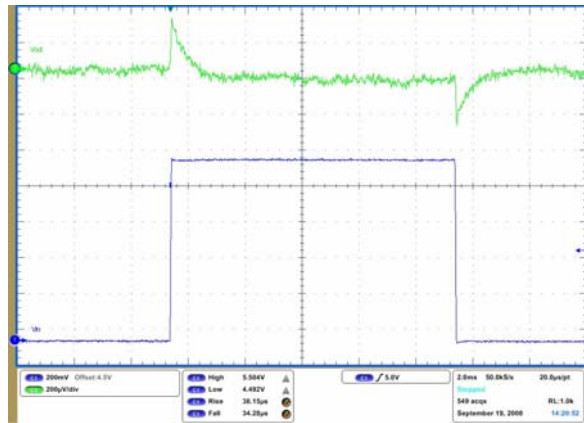
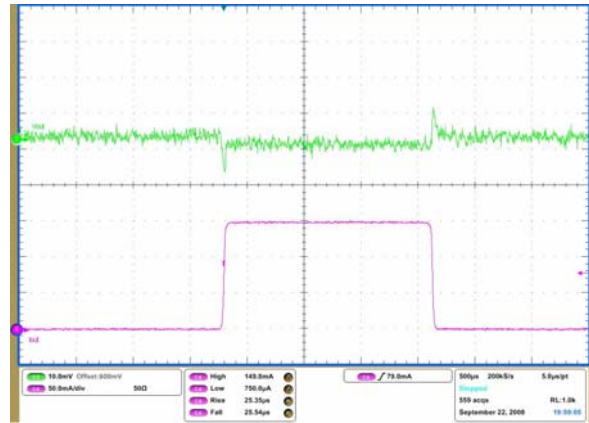

Figure 16. Line transient ( $V_{OUT} = 3.3\text{ V}$ )



$C_{OUT} = 1\ \mu\text{F}$ ;  $V_{IN} = V_{EN}$  = from 4.5 to 5.5 V;  $V_{OUT} = 3.3\text{ V}$ ;  $I_{OUT} = 1\text{ mA}$ ;  $t_{rise} = t_{fall} = 25\ \mu\text{s}$

Figure 17. Load transient ( $V_{OUT} = 0.8\text{ V}$ )



$C_{IN} = C_{OUT} = 1\ \mu\text{F}$ ;  $V_{IN} = V_{EN} = 2.4\text{ V}$ ;  $V_{OUT} = 0.8\text{ V}$ ;  $I_{OUT}$  from 0.1 to 150 mA;  $t_{rise} = t_{fall} = 25\ \mu\text{s}$

Figure 18. Load transient ( $V_{OUT} = 3.3\text{ V}$ )

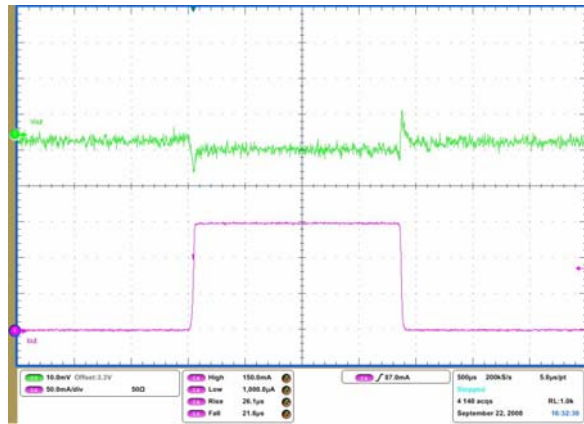

$C_{IN} = C_{OUT} = 1\ \mu\text{F}$ ;  $V_{IN} = V_{EN} = 4.3\text{ V}$ ;  $V_{OUT} = 3.3\text{ V}$ ;  $I_{OUT}$  from 0.1 to 150 mA;  $t_{rise} = t_{fall} = 25\ \mu\text{s}$

Figure 19. Start-up transient

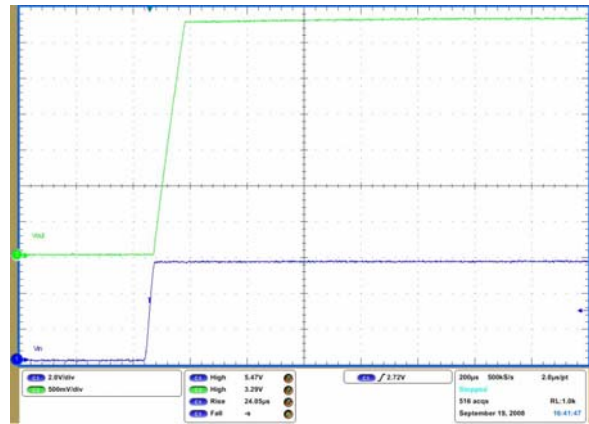

$C_{OUT} = 1\ \mu\text{F}$ ;  $V_{IN} = V_{EN}$  = from 0 to 5.5 V;  $V_{OUT} = 3.3\text{ V}$ ;  $I_{OUT} = 150\text{ mA}$

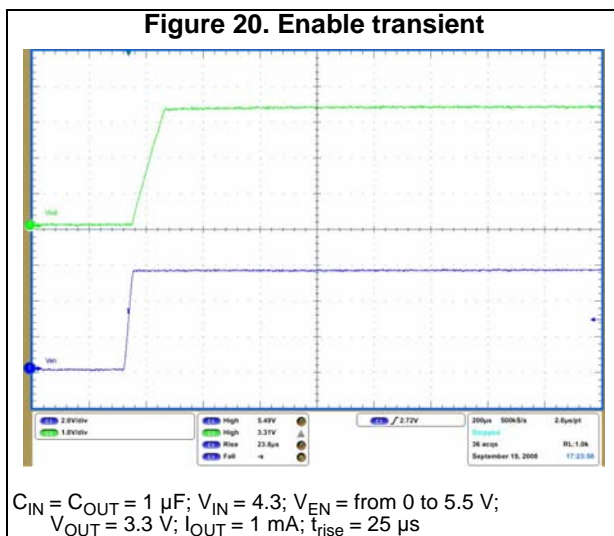

## 7 Package information

In order to meet environmental requirements, ST offers these devices in different grades of ECOPACK® packages, depending on their level of environmental compliance. ECOPACK® specifications, grade definitions and product status are available at: [www.st.com](http://www.st.com). ECOPACK® is an ST trademark.

### 7.1 SOT323-5L package information

Figure 21. SOT323-5L package outline

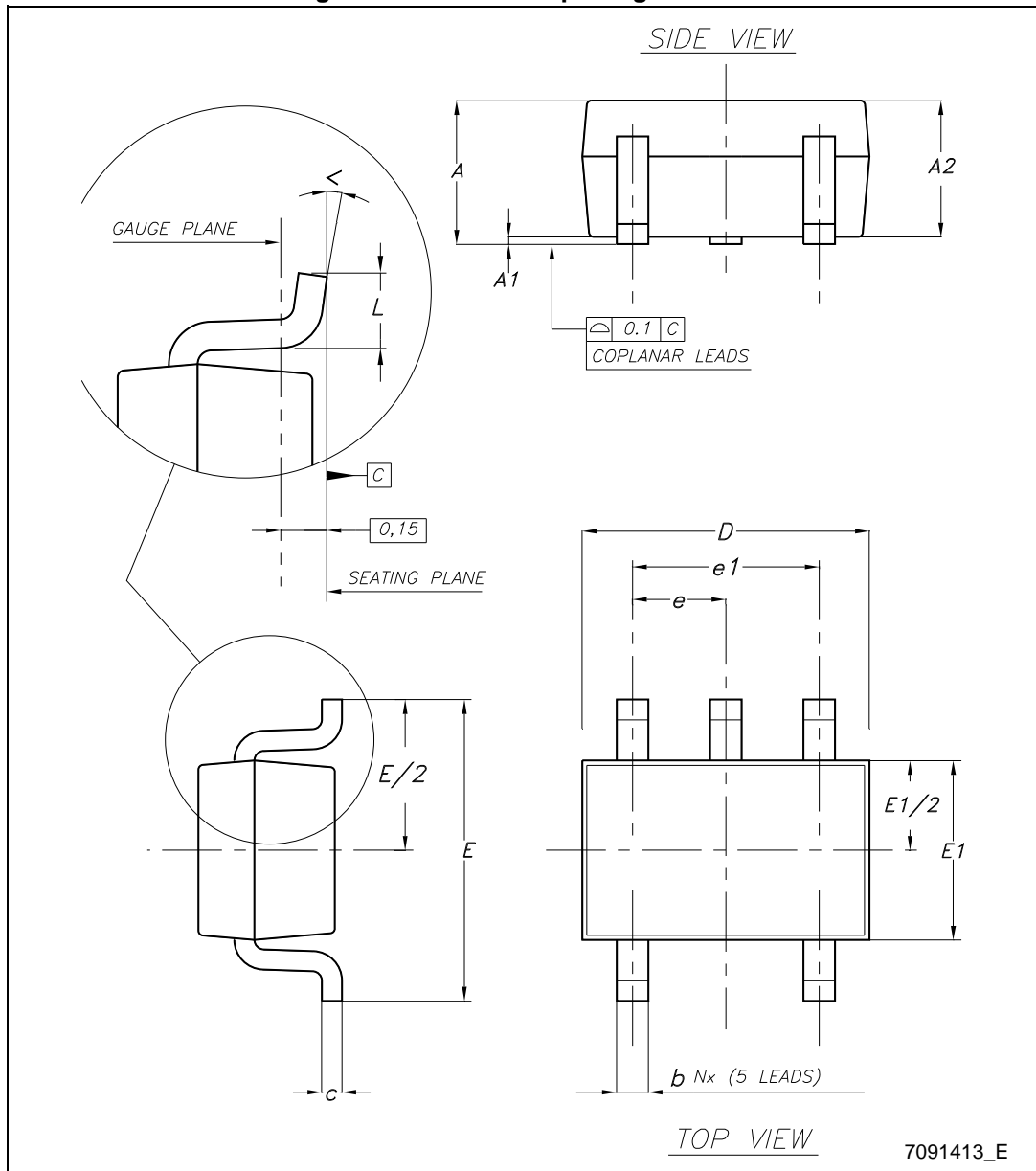

Table 6. SOT323-5L package mechanical data

Dim.	mm		
	Min.	Typ.	Max.
A	0.80		1.10
A1	0		0.10
A2	0.80	0.90	1
b	0.15		0.30
c	0.10		0.22
D	1.80	2	2.20
E	1.80	2.10	2.40
E1	1.15	1.25	1.35
e		0.65	
e1		1.30	
L	0.26	0.36	0.46
<	0°		8°

### 7.2 SOT323-5L packing information

Figure 22. SOT323-5L tape and reel outline

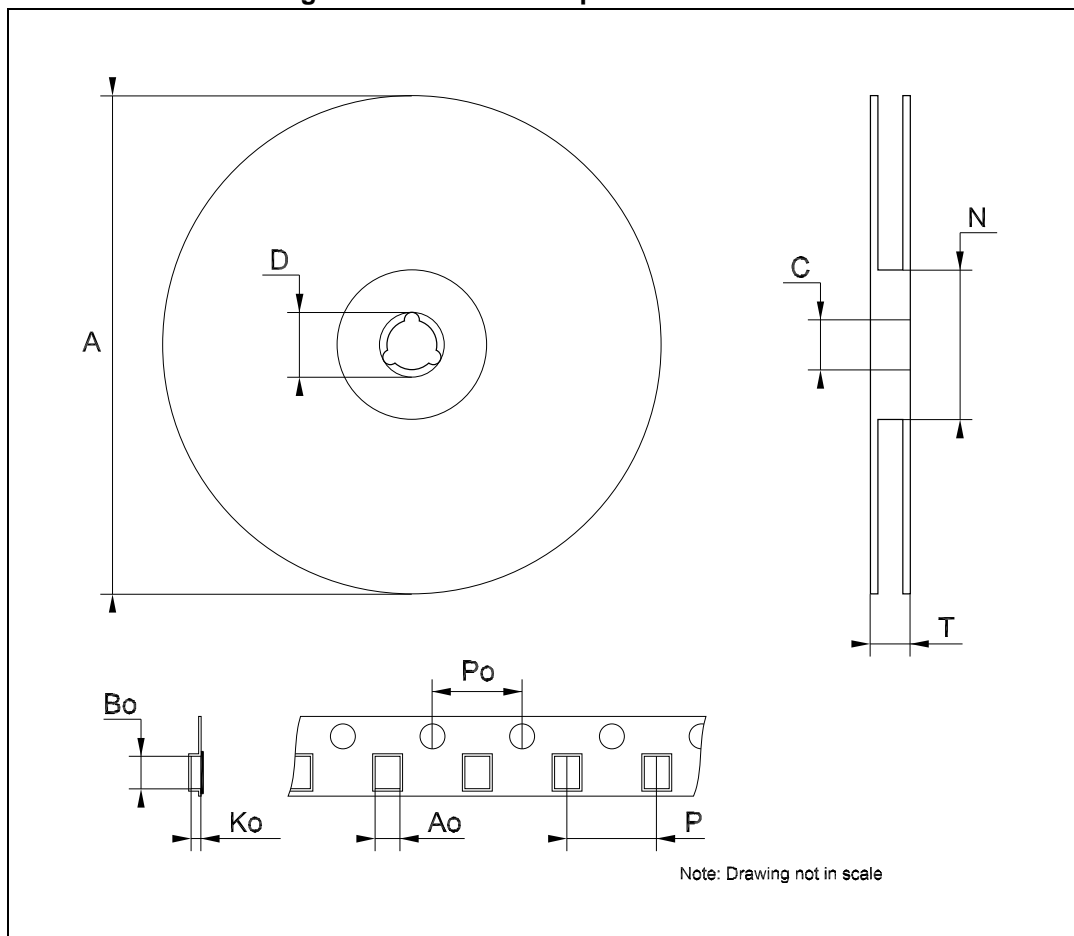

Table 7. SOT323-5L tape and reel mechanical data

Dim.	mm		
	Min.	Typ.	Max.
A	175	180	185
C	12.8	13	13.2
D	20.2		
N	59.5	60	60.5
T			14.4
Ao		2.25	
Bo		3.17	
Ko		1.2	
Po	3.9	4.0	4.1
P	3.9	4.0	4.2



## 8 Revision history

**Table 8. Document revision history**

Date	Revision	Changes
10-May-2010	1	Initial release.
21-Dec-2011	2	Modified: operating input voltage ( $V_{IN}$ ) min. value <i>Table 5 on page 7</i> . Availability LD59015C08R code <i>Table 1 on page 1</i> .
06-Jul-2012	3	Updated: <i>Table 1 on page 1</i> .
24-Apr-2014	4	Part number LD59015xx changed to LD59015. Updated the description in cover page and <i>Section 7: Package mechanical data</i> . Added <i>Section 8: Packaging mechanical data</i> . Minor text changes.
05-Jul-2017	5	Updated features and <a href="#">Table 1: Device summary</a> . Minor text changes.

**IMPORTANT NOTICE – PLEASE READ CAREFULLY**

STMicroelectronics NV and its subsidiaries ("ST") reserve the right to make changes, corrections, enhancements, modifications, and improvements to ST products and/or to this document at any time without notice. Purchasers should obtain the latest relevant information on ST products before placing orders. ST products are sold pursuant to ST's terms and conditions of sale in place at the time of order acknowledgement.

Purchasers are solely responsible for the choice, selection, and use of ST products and ST assumes no liability for application assistance or the design of Purchasers' products.

No license, express or implied, to any intellectual property right is granted by ST herein.

Resale of ST products with provisions different from the information set forth herein shall void any warranty granted by ST for such product.

ST and the ST logo are trademarks of ST. All other product or service names are the property of their respective owners.

Information in this document supersedes and replaces information previously supplied in any prior versions of this document.

© 2017 STMicroelectronics – All rights reserved

## X-ON Electronics

Largest Supplier of Electrical and Electronic Components

*Click to view similar products for [LDO Voltage Regulators](#) category:*

*Click to view products by [STMicroelectronics](#) manufacturer:*

Other Similar products are found below :

[AP7363-SP-13](#) [L79M05TL-E](#) [TCR3DF185,LM\(CT](#) [TCR3DF24,LM\(CT](#) [TCR3DF285,LM\(CT](#) [TCR3DF31,LM\(CT](#) [TCR3DF45,LM\(CT](#)  
[MP2013GQ-33-Z](#) [059985X](#) [NCP4687DH15T1G](#) [701326R](#) [TCR2EN28,LF\(S](#) [NCV8170AXV250T2G](#) [TCR3DF27,LM\(CT](#)  
[TCR3DF19,LM\(CT](#) [TCR3DF125,LM\(CT](#) [TCR2EN18,LF\(S](#) [AP2112R5A-3.3TRG1](#) [AP7315-25W5-7](#) [IFX30081LDVGRNXUMA1](#)  
[NCV47411PAAJR2G](#) [AP2113KTR-G1](#) [AP2111H-1.2TRG1](#) [ZLDO1117QK50TC](#) [AZ1117IH-1.8TRG1](#) [AZ1117ID-ADJTRG1](#)  
[TCR3DG12,LF](#) [MIC5514-3.3YMT-T5](#) [MIC5512-1.2YMT-T5](#) [MIC5317-2.8YM5-T5](#) [SCD7912BTG](#) [NCP154MX180270TAG](#) [SCD33269T-](#)  
[5.0G](#) [NCV8170BMX330TCG](#) [NCV8170AMX120TCG](#) [NCP706ABMX300TAG](#) [NCP153MX330180TCG](#) [NCP114BMX075TCG](#)  
[MC33269T-3.5G](#) [CAT6243-ADJCMT5T](#) [TCR3DG33,LF](#) [AP2127N-1.0TRG1](#) [TCR4DG35,LF](#) [LT1117CST-3.3](#) [TAR5S15U\(TE85L,F\)](#)  
[TAR5S18U\(TE85L,F\)](#) [TCR3UG19A,LF](#) [TCR4DG105,LF](#) [NCV8170AMX360TCG](#) [MIC94310-NYMT-T5](#)