

High input voltage 85 mA LDO linear regulator

Datasheet - production data

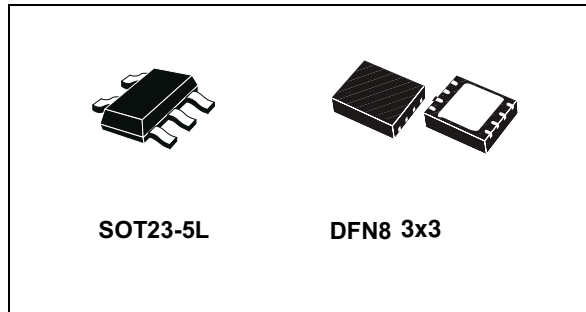

Features

- 4.3 V to 24 V input voltage
- Low-dropout voltage (500 mV typ. at 85 mA)
- Very low quiescent current (5 μ A typ. at full load)
- 85 mA guaranteed output current
- Output voltages 3.3 V, 4.2 V and 5.0 V (other versions available on request)
- Compatible with ceramic output capacitors from 0.47 μ F to 10 μ F
- Internal current limit
- Packages: SOT23-5L and DFN8 3x3
- Temperature range: from -40 °C to 125 °C

Applications

- Mobile phones
- Industrial
- battery-powered systems

Description

The LDK715 is a high voltage, ultra low quiescent current and low drop linear regulator capable of providing an output current in excess of 85 mA. The device operates over an input voltage range from 4.3 V to 24 V, and it is stable with output ceramic capacitors. Fault condition protection includes short-circuit current limitation. The ultra low quiescent current of 5 μ A at full load makes it highly suitable for low power applications and battery-powered systems. The wide input voltage range makes the LDK715 an ideal solution for low power industrial applications. The LDK715 is available in SOT23-5, or DFN8 3x3 - 8 leads.

Table 1. Device summary

Order codes		Output voltage
SOT23-5L	DFN8 3x3	
LDK715M33R	LDK715PU33R	3.3 V
LDK715M42R	LDK715PU42R	4.2 V
LDK715M50R	LDK715PU50R	5.0 V

Contents

1	Diagram	3
2	Pin configuration	4
3	Maximum ratings	5
4	Electrical characteristics	6
	4.1 External capacitor requirements	7
	4.2 Power dissipation and junction temperature	7
5	Typical application	8
6	Typical performance characteristics	9
7	Package information	11
	7.1 SOT23-5L package information	11
	7.2 DFN8 3x3 package information	13
8	Packaging information	15
	8.1 Tape and reel SOT23-5L	15
	8.2 Tape and reel DFN8 3x3	16
9	Revision history	18

1 Diagram

Figure 1. Block diagram

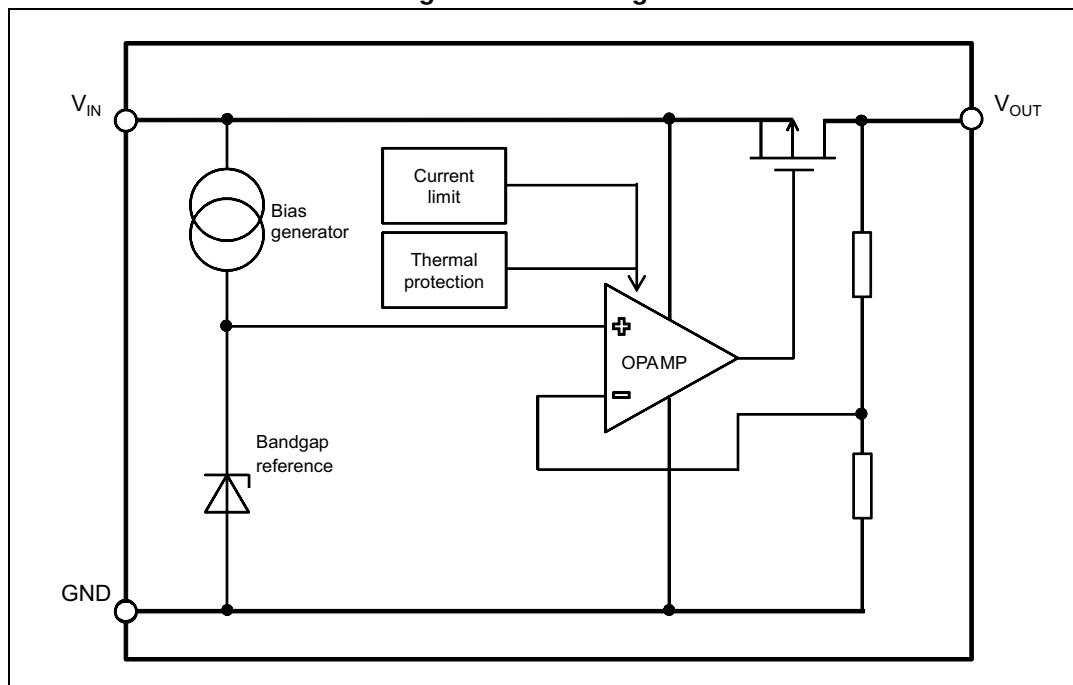

2 Pin configuration

Figure 2. Pin connection (top view)

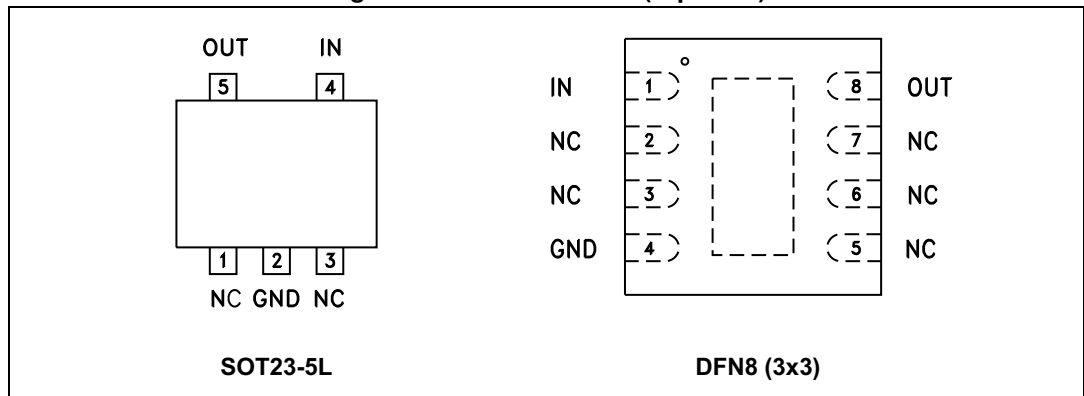

Table 2. Pin description for DFN8 3x3

Symbol	Pin number	Name and function
IN	1	Input voltage
NC	2, 3, 5, 6, 7	Not internally connected
GND	4	Common ground
OUT	8	Output voltage
Exp. pad		Leave floating or connect to GND

Table 3. Pin description for SOT23-5L

Symbol	Pin number	Name and function
IN	4	Input voltage
NC	1,3	Not internally connected
GND	2	Common ground
OUT	5	Output voltage

3 Maximum ratings

Table 4. Absolute maximum ratings

Symbol	Parameter	Value	Unit
V_{IN}	DC input voltage	From -0.3 to 26	V
V_{OUT}	DC output voltage	From -0.3 to $V_{IN} + 0.3$	V
I_{OUT}	Continuous output current	According to package power dissipation	A
$P_D^{(1), (2)}$	Maximum power dissipation, DFN package	2	W
	Maximum power dissipation, SOT23-5L package	0.45	
T_{STG}	Storage temperature range	-65 to 150	°C
T_{OP}	Operating junction temperature range	-40 to 125	°C

- P_D is based on an operating temperature of 25 °C or less. It must be derated according to the operating temperature.
- The LDK715 has an internal constant current limit feature. Take care not to exceed the power dissipation ratings of the package also during current limit and short-circuit events.

Note: Absolute maximum ratings are those values beyond which damage to the device may occur. Functional operation under these conditions is not implied.

Table 5. Thermal data

Symbol	Parameter	SOT23-5L	DFN8	Unit
R_{thJA}	Thermal resistance junction ambient	195	52	°C/W

4 Electrical characteristics

$T_J = 25\text{ °C}$, $V_{IN} = V_{OUT(NOM)} + 1\text{ V}$, $C_{IN} = 0.1\text{ }\mu\text{F}$, $C_{OUT} = 1\text{ }\mu\text{F}$, $I_{OUT} = 1\text{ mA}$, unless otherwise specified^(a).

Table 6. Electrical characteristics

Symbol	Parameter	Test conditions	Min.	Typ.	Max.	Unit	
V_{IN}	Operating input voltage	$I_{OUT} = 85\text{ mA}$, $T_J = -40\text{ °C to }125\text{ °C}$	4.3	-	24	V	
I_{OUT}	Output current	$V_{IN} = V_{OUT(NOM)} + 1$ to 24 V, $T_J = -40\text{ °C to }125\text{ °C}$	0	-	85	mA	
V_{OUT}	V_{OUT} accuracy ⁽¹⁾	$T_J = 25\text{ °C}$	-1	-	+1	%	
		$V_{IN} = V_{OUT(NOM)} + 1$ to 24 V, $T_J = -40\text{ °C to }125\text{ °C}$	-2	-	+2		
ΔV_{OUT}	Line regulation	$V_{IN} = V_{OUT(NOM)} + 1$ to 24 V to 24 V, $I_{OUT} = 1\text{ mA}$, $T_J = -40\text{ °C to }125\text{ °C}$	-	0.001	0.004	%/V	
ΔV_{OUT}	Load regulation	$I_{OUT} = 100\text{ }\mu\text{A to }85\text{ mA}$, $T_J = -40\text{ °C to }125\text{ °C}$	-	0.002	0.003	%/mA	
V_{DROP}	Drop output voltage ⁽²⁾	$I_{OUT} = 85\text{ mA}$, $T_J = -40\text{ °C to }125\text{ °C}$	-	500	1000	mV	
e_N	Output noise voltage ⁽³⁾	200 Hz to 100 kHz, $I_{OUT} = 50\text{ mA}$, $C_{OUT} = 10\text{ }\mu\text{F}$, $T_J = -40\text{ °C to }125\text{ °C}$	-	-	210	μV_{RMS}	
SVR	Supply voltage rejection	$V_{IN} = V_{OUT(NOM)} + 1\text{ V} \pm V_{RIPPLE}$, $V_{RIPPLE} = 0.2\text{ V}$, $I_{OUT} = 1\text{ mA}$, $C_{OUT} = 10\text{ }\mu\text{F}$	$f = 1\text{ kHz}$	-	38	-	dB
		$T_J = -40\text{ °C to }125\text{ °C}$	$f = 100\text{ kHz}$	-	57		
I_Q	Quiescent current	$I_{OUT} = 0\text{ mA to }85\text{ mA}$, $T_J = -40\text{ °C to }125\text{ °C}$		-	5	7	μA
			$V_{IN} = 24\text{ V}$	-	-	8.5	
I_{SC}	Short-circuit current	$V_{OUT} = 0$, $T_J = -40\text{ °C to }125\text{ °C}$ $V_{IN} = V_{OUT(NOM)} + 1$ to 24 V	120	-	-	mA	
T_{ON}	Turn on time ⁽⁴⁾	$V_{IN} = V_{OUT(NOM)} + 1$ to 24 V, $C_{OUT} = 10\text{ }\mu\text{F}$, $I_{OUT} = 60\text{ mA}$, $T_J = -40\text{ °C to }125\text{ °C}$	-	0.7	-	ms	
C_{OUT}	Output capacitor	Capacitance $f = 100\text{ kHz}$	0.47	-	-	μF	

1. For $V_{OUT(NOM)} < 3.3\text{ V}$, $V_{IN} = 4.3\text{ V}$.

2. Dropout voltage is the input-to-output voltage difference at which the output voltage is 100 mV below its nominal value.

3. Guaranteed by design.

4. Turn-on time is time measured between the input just exceeding 90% of its final value and the output voltage just reaching 95% of its nominal value.

a. For $V_{OUT(NOM)} < 3.3\text{ V}$, $V_{IN} = 4.3\text{ V}$.

4.1 External capacitor requirements

A 0.1 μF or a larger input bypass capacitor, connected between IN and GND and located close to the device, is recommended. In this manner, the transient response and noise rejection of the power supply, as a whole, improve. A higher value of the input capacitor may be necessary if large, fast-rise-time load transients are present in the application and if the device is several inches far from the power source.

The LDK715 requires an output capacitor connected between OUT and GND to stabilize the internal control loop. Please refer to [Figure 7](#) for the allowable output capacitance and ESR combinations.

4.2 Power dissipation and junction temperature

For a reliable operation, junction temperature should not exceed 125 °C. This limits the power dissipation the regulator can handle in any application. To guarantee that the junction temperature is within acceptable limits, calculate the maximum allowable dissipation, $P_{D(\text{max})}$, and the dissipation, P_D , which must be less than or equal to $P_{D(\text{max})}$.

The maximum power dissipation limit is given by the following equation:

Equation 1

$$P_{D(\text{max})} = (T_{J\text{MAX}} - T_A) / R_{\text{thJA}}$$

where:

$T_{J\text{MAX}}$ is the maximum allowable junction temperature

R_{thJA} is the thermal resistance junction to ambient for the package

T_A is the ambient temperature

The regulator dissipation is calculated by the following equation:

Equation 2

$$P_D = (V_{\text{IN}} - V_{\text{out}}) \times I_{\text{out}}$$

Power dissipation coming from quiescent current is negligible.

The ST715 features the internal current limit. During normal operation, it limits the output current to approximately 350 mA. When the current limit engages, the output voltage scales back linearly until the overcurrent condition ends. Do not exceed the power dissipation ratings of the package.

5 Typical application

Figure 3. Application circuit

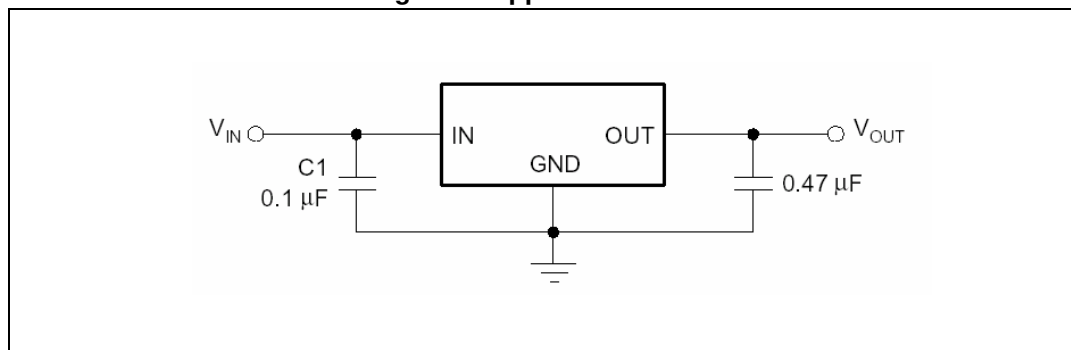

6 Typical performance characteristics

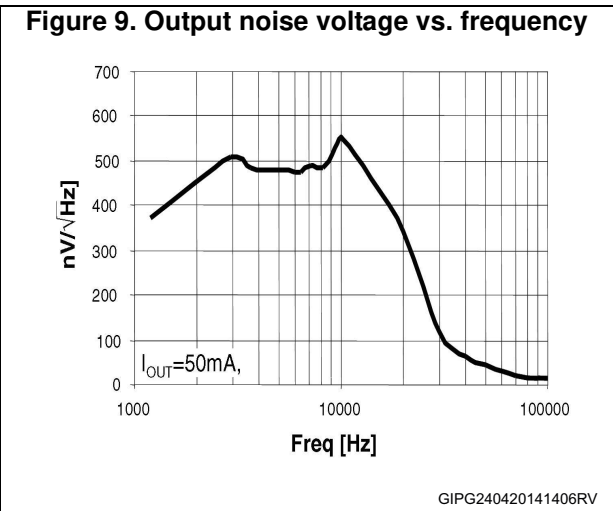
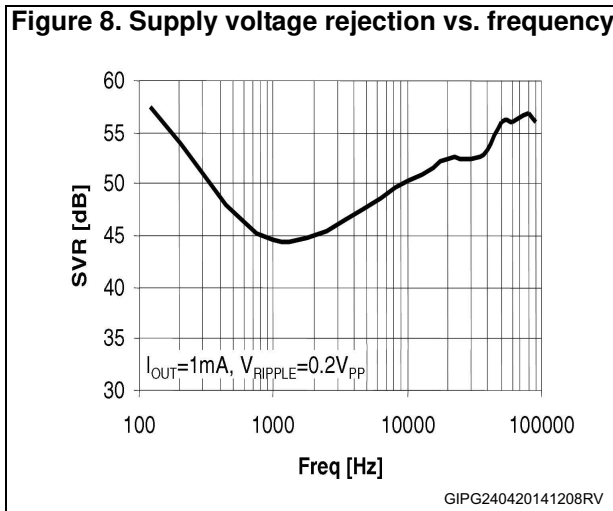
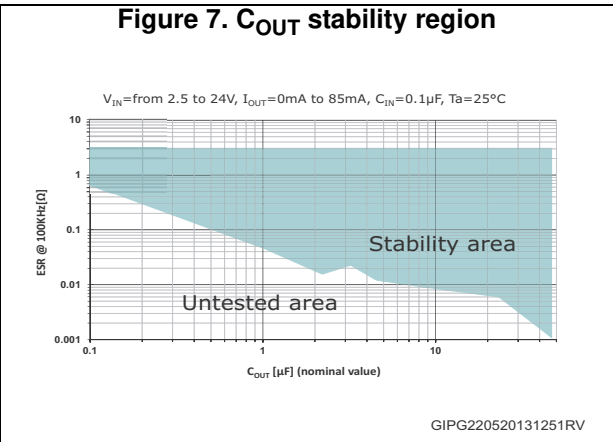
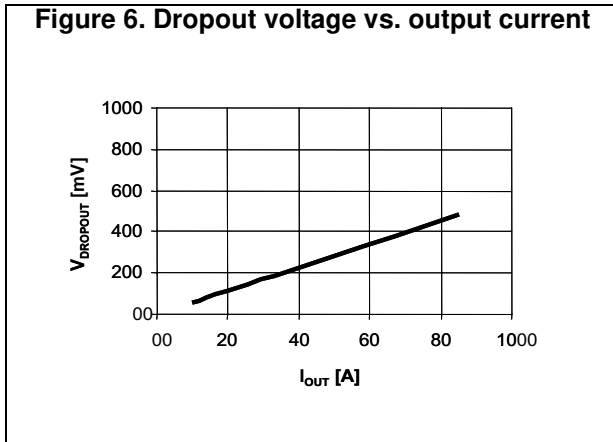
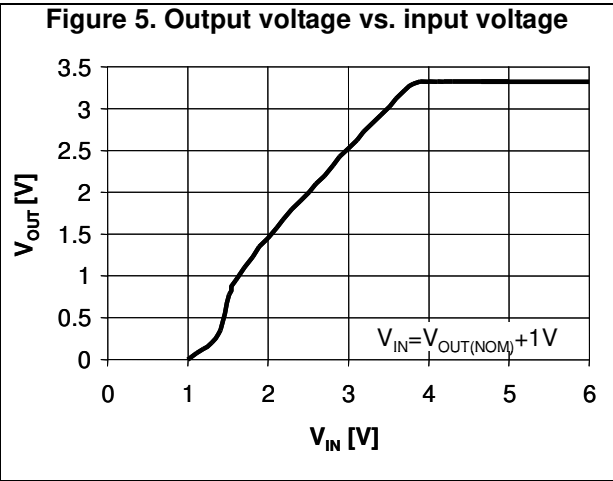
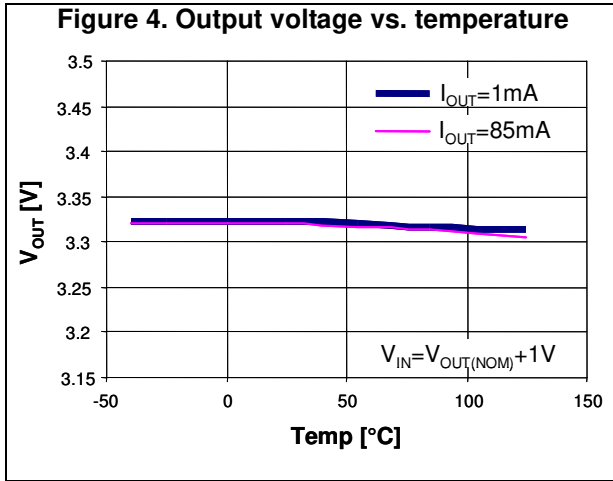
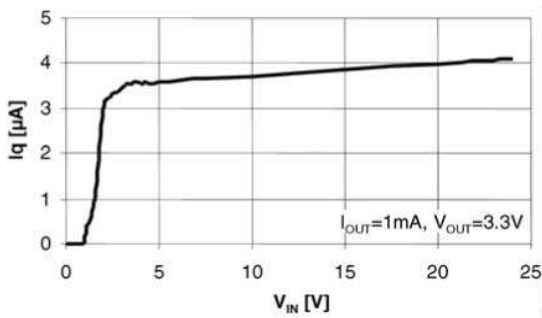
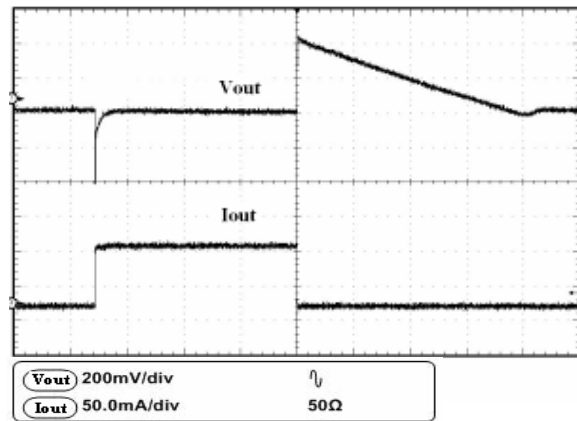

Figure 10. Quiescent current vs. input voltage



GIPG230420141425RV

Figure 11. Load transient



$C_{IN} = C_{OUT} = 1 \mu F$, $V_{EN} = V_{IN} = 24 V$, $I_{OUT} =$ from 1 mA to 85 mA, $t_R = t_F = 5 \mu S$

Figure 12. Line transient

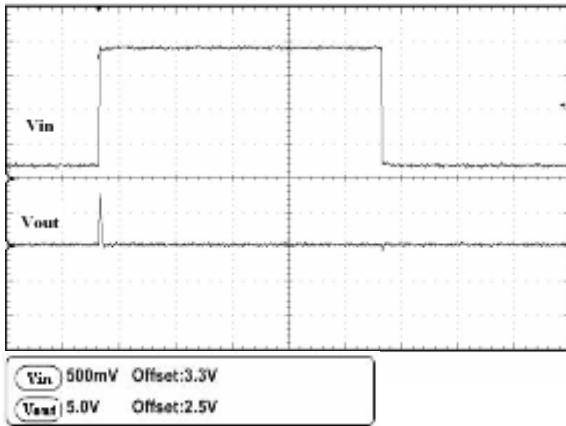

$C_{OUT} = 1 \mu F$; $V_{IN} = V_{EN} =$ from 4.3 to 22 V; $I_{OUT} = 1 mA$; $t_R = t_F = 5 \mu s$

Figure 13. Enable transient

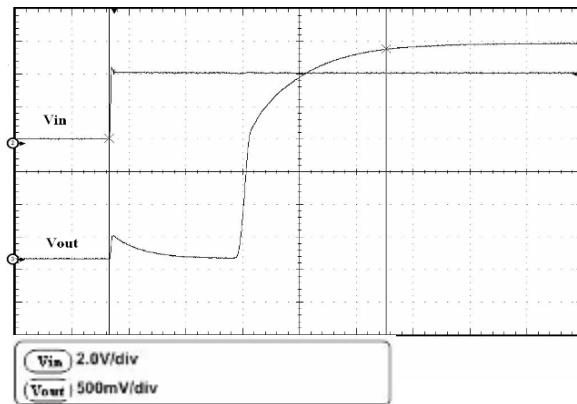

$C_{IN} = C_{OUT} = 1 \mu F$, $V_{EN} = V_{IN} = 0$ to 4.3 V, $I_{OUT} = 1 mA$

7 Package information

In order to meet environmental requirements, ST offers these devices in different grades of ECOPACK packages, depending on their level of environmental compliance. ECOPACK specifications, grade definitions and product status are available at: www.st.com. ECOPACK is an ST trademark.

7.1 SOT23-5L package information

Figure 14. SOT23-5L package outline

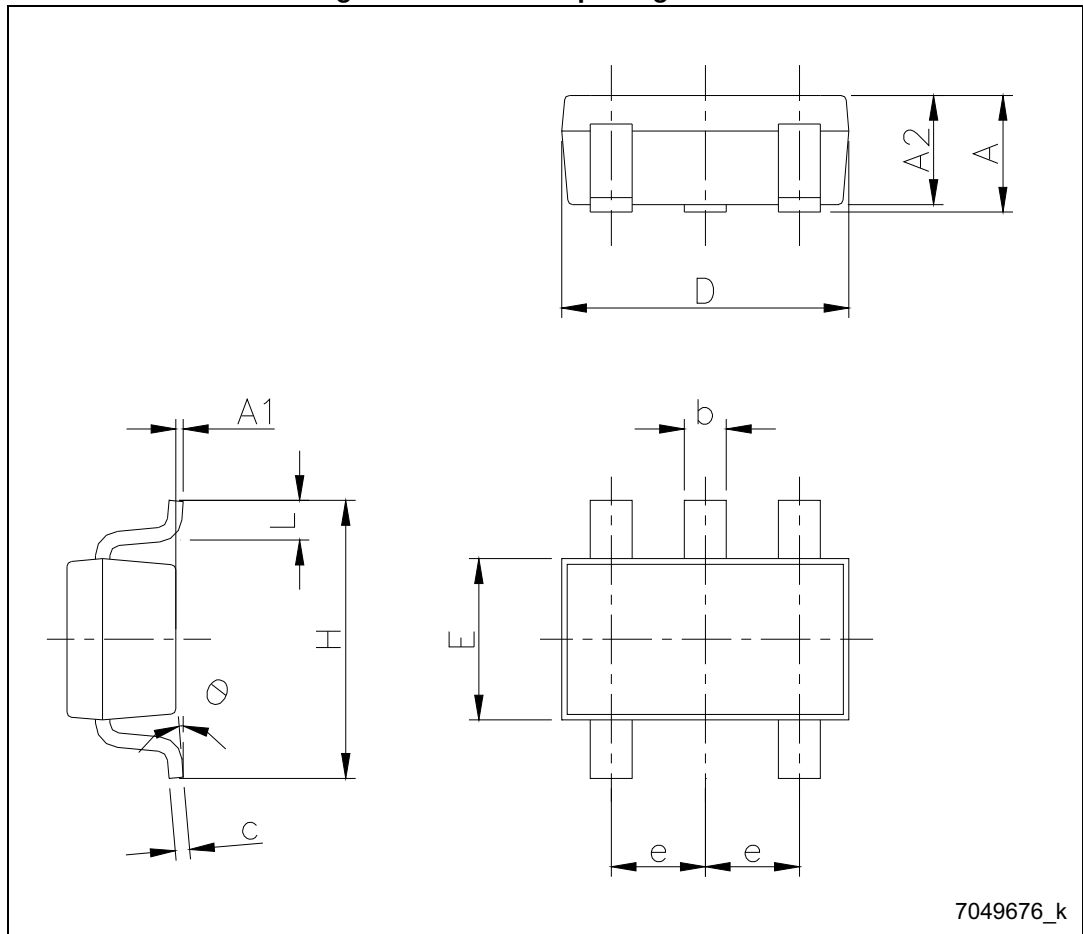
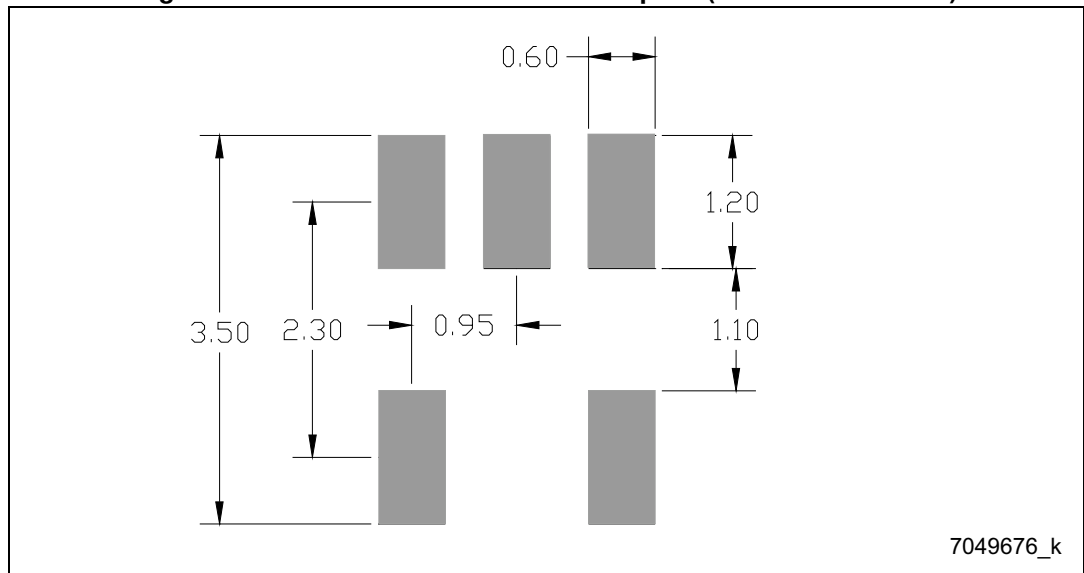

Table 7. SOT23-5L package mechanical data

Symbol	Dimensions (mm)		
	Min.	Typ.	Max.
A	0.90	-	1.45
A1	0.00	-	0.15
A2	0.90	-	1.30
b	0.30	-	0.50
c	0.009	-	0.20
D	2.80	2.95	3.05
E	1.50	1.60	1.75
e	-	0.95	-
H	2.60	2.80	3.00
L	0.30	-	0.60
q	0.00	-	8.00

Figure 15. SOT23-5L recommended footprint (dimensions in mm)



7.2 DFN8 3x3 package information

Figure 16. DFN8 3x3 package outline

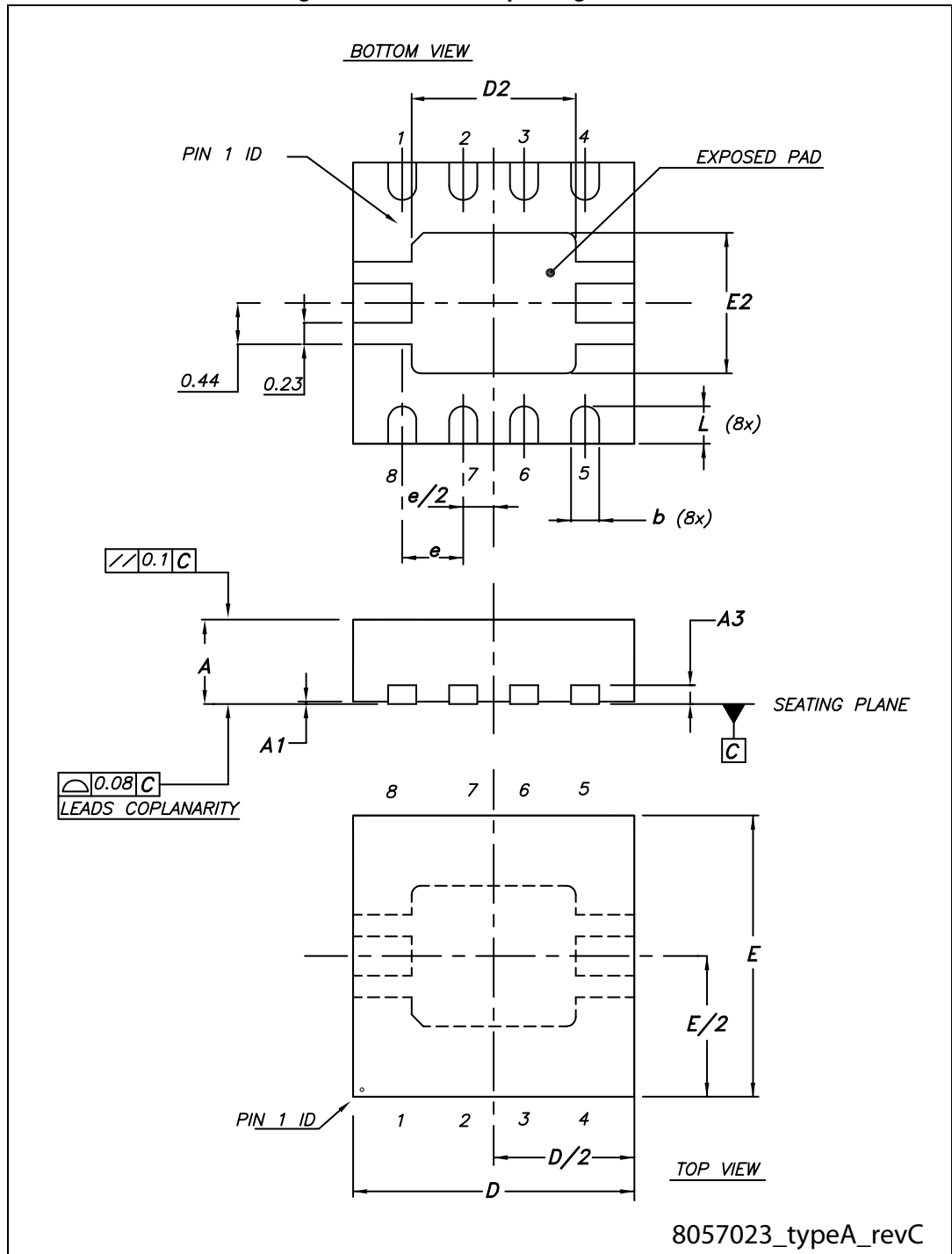
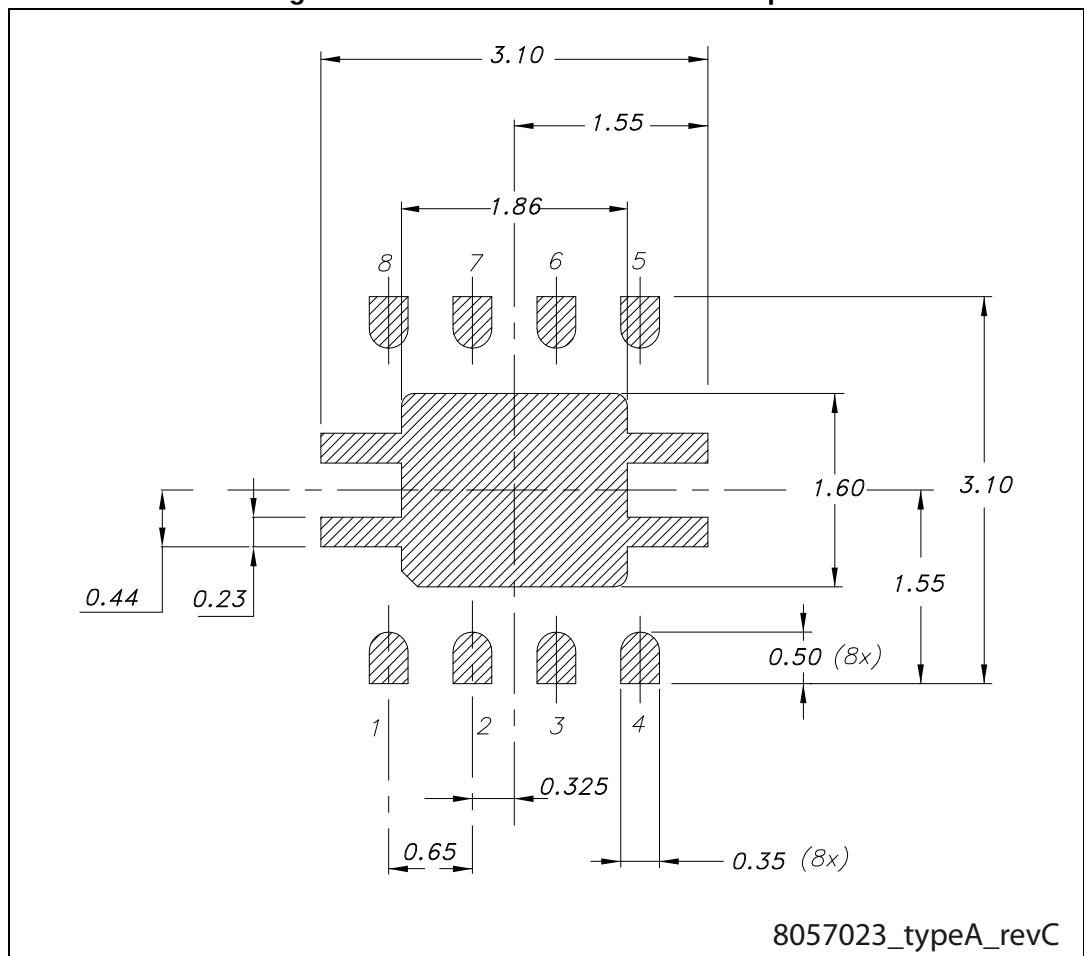

Table 8. DFN8 3x3 package mechanical data

Symbol	Dimensions (mm)		
	Min	Typ	Max.
A	0.80	0.90	1.00
A1	0.00	0.02	0.05
A3	-	0.20	-
b	0.25	0.30	0.35
D	2.85	3.00	3.15
D2	1.603	1.753	1.853
E	2.85	3.00	3.15
E2	1.345	1.495	1.595
e	0.00	0.65	-
L	0.30	0.40	0.50

Figure 17. DFN8 3x3 recommended footprint



8 Packaging information

8.1 Tape and reel SOT23-5L

Figure 18. SOT23-5L tape and reel drawing

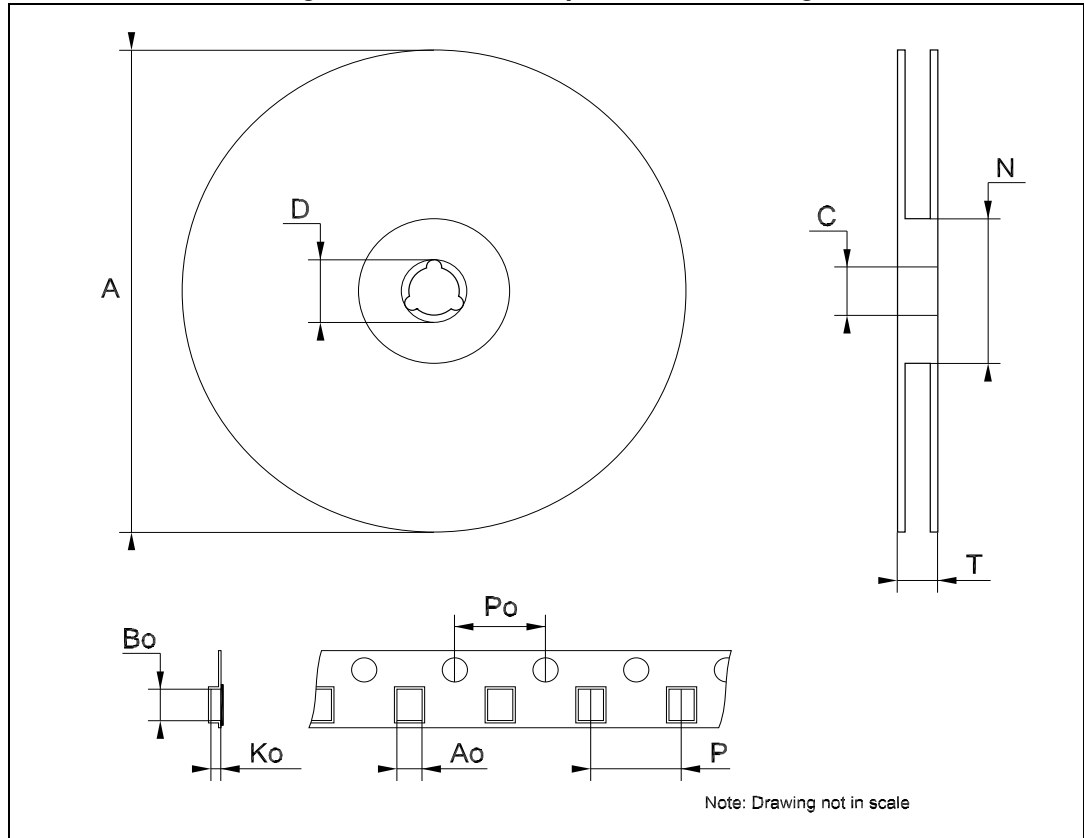
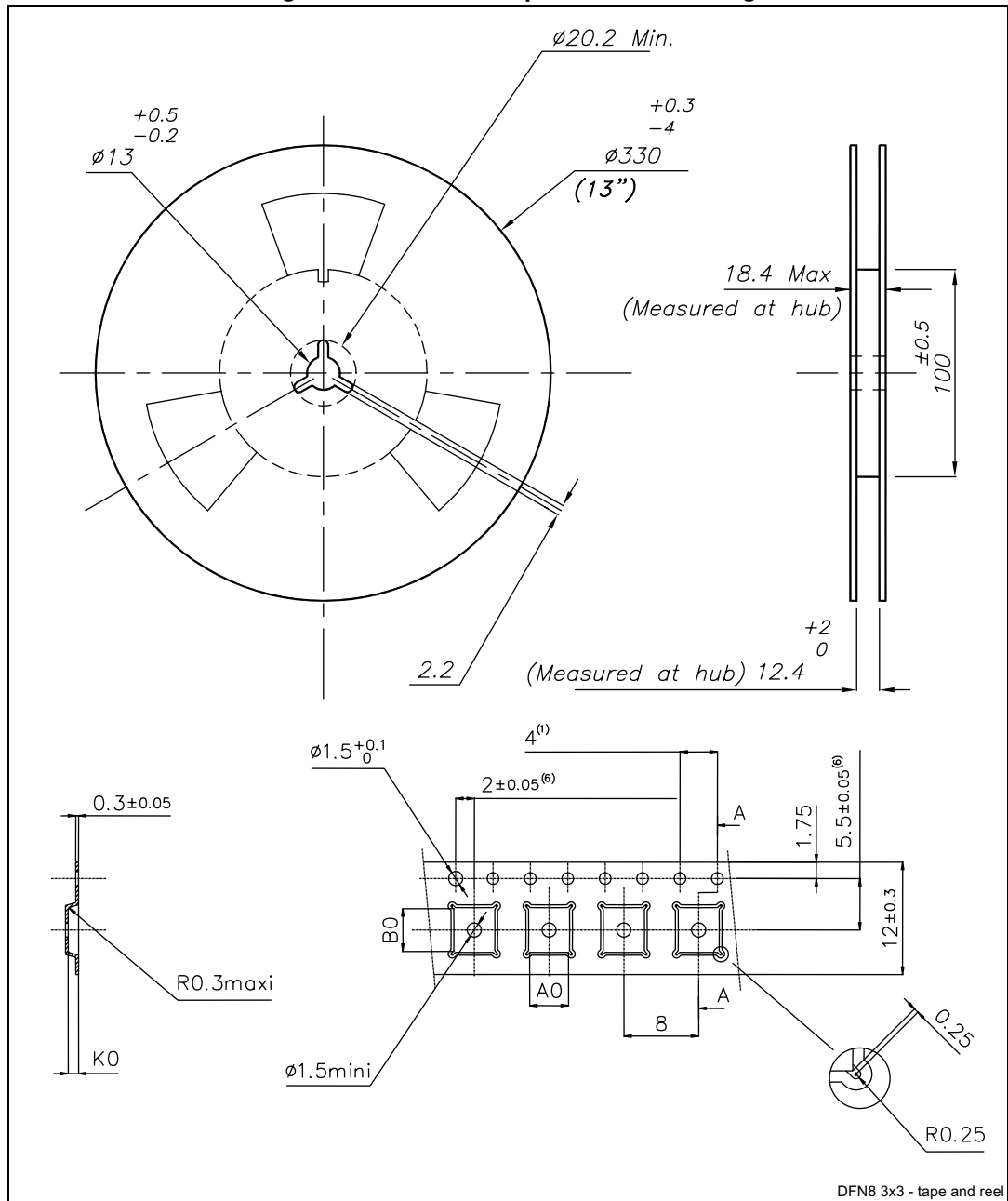

Table 9. SOT23-5L tape and reel mechanical data

Symbol	Dimensions (mm)		
	Min.	Typ.	Max.
A		-	180.00
C	12.80	13.00	13.20
D	20.20	-	-
N	60.00	-	-
T	-	-	14.40
Ao	3.13	3.23	3.33
Bo	3.07	3.17	3.27
Ko	1.27	1.37	1.47
Po	3.90	4.00	4.10
P	3.90	4.00	4.10

8.2 Tape and reel DFN8 3x3

Figure 19. DFN8 3x3 tape and reel drawing



1. 10 sprocket hole pitch cumulative tolerance ± 0.2 .
2. Camber not to exceed 1 mm in 100 mm.
3. Material: PS + C.
4. A0 and B0 measured as indicated.
5. K0 measured from a plane on the inside bottom of the pocket to the top surface of the carrier.
6. Pocked position relative to sprocket hole measured as true position of pocket, not pocket hole.

Table 10. DFN8 3x3 tape and reel mechanical data

Symbol	Dimensions (mm)		
	Min.	Typ.	Max.
A	-	-	180.00
C	12.80	-	13.20
D	20.20	-	-
N	60.00	-	-
T	-	-	14.40
Ao	-	3.30	-
Bo	-	3.30	-
Ko	-	1.10	-
Po	-	4.00	-
P	-	8.00	-

9 Revision history

Table 11. Document revision history

Date	Revision	Changes
09-Jul-2014	1	Initial release.
28-Nov-2017	2	Updated Table 1 on page 1 (removed references to note 1. from LDK715M33R, LDK715PU33R, and LDK715PU42R). Added Figure 19 on page 16. Minor modifications throughout document.
07-Apr-2020	3	Updated Table 2: Pin description for DFN8 3x3 .

IMPORTANT NOTICE – PLEASE READ CAREFULLY

STMicroelectronics NV and its subsidiaries (“ST”) reserve the right to make changes, corrections, enhancements, modifications, and improvements to ST products and/or to this document at any time without notice. Purchasers should obtain the latest relevant information on ST products before placing orders. ST products are sold pursuant to ST’s terms and conditions of sale in place at the time of order acknowledgement.

Purchasers are solely responsible for the choice, selection, and use of ST products and ST assumes no liability for application assistance or the design of Purchasers’ products.

No license, express or implied, to any intellectual property right is granted by ST herein.

Resale of ST products with provisions different from the information set forth herein shall void any warranty granted by ST for such product.

ST and the ST logo are trademarks of ST. For additional information about ST trademarks, please refer to www.st.com/trademarks. All other product or service names are the property of their respective owners.

Information in this document supersedes and replaces information previously supplied in any prior versions of this document.

© 2020 STMicroelectronics – All rights reserved

X-ON Electronics

Largest Supplier of Electrical and Electronic Components

Click to view similar products for [LDO Voltage Regulators](#) category:

Click to view products by [STMicroelectronics](#) manufacturer:

Other Similar products are found below :

[AP7363-SP-13](#) [L79M05TL-E](#) [PT7M8202B12TA5EX](#) [TCR3DF185,LM\(CT](#) [TCR3DF24,LM\(CT](#) [TCR3DF285,LM\(CT](#) [TCR3DF31,LM\(CT](#)
[TCR3DF45,LM\(CT](#) [MP2013GQ-33-Z](#) [059985X](#) [NCP4687DH15T1G](#) [701326R](#) [TCR2EN28,LF\(S](#) [NCV8170AXV250T2G](#)
[TCR3DF27,LM\(CT](#) [TCR3DF19,LM\(CT](#) [TCR3DF125,LM\(CT](#) [TCR2EN18,LF\(S](#) [AP2112R5A-3.3TRG1](#) [AP7315-25W5-7](#)
[IFX30081LDVGRNXUMA1](#) [NCV47411PAAJR2G](#) [AP2113KTR-G1](#) [AP2111H-1.2TRG1](#) [ZLDO1117QK50TC](#) [AZ1117IH-1.8TRG1](#)
[AZ1117ID-ADJTRG1](#) [TCR3DG12,LF](#) [MIC5514-3.3YMT-T5](#) [MIC5512-1.2YMT-T5](#) [MIC5317-2.8YM5-T5](#) [SCD7912BTG](#)
[NCP154MX180270TAG](#) [SCD33269T-5.0G](#) [NCV8170BMX330TCG](#) [NCV8170AMX120TCG](#) [NCP706ABMX300TAG](#)
[NCP153MX330180TCG](#) [NCP114BMX075TCG](#) [MC33269T-3.5G](#) [CAT6243-ADJCMT5T](#) [TCR3DG33,LF](#) [AP2127N-1.0TRG1](#)
[TCR4DG35,LF](#) [LT1117CST-3.3](#) [LT1117CST-5](#) [TAR5S15U\(TE85L,F\)](#) [TAR5S18U\(TE85L,F\)](#) [TCR3UG19A,LF](#) [TCR4DG105,LF](#)