



LET20045C

RF power transistor from the LdmoST family of n-channel enhancement-mode lateral MOSFETs

Features

- Excellent thermal stability
- Common source configuration
- P_{OUT} (@ 28 V)= 54 W with 13.3 dB gain @ 2000 MHz
- P_{OUT} (@ 36 V)= 65 W with 12.5 dB gain @ 2000 MHz
- BeO free package
- In compliance with the 2002/95/EC European directive

Description

The LET20045C is a common source n-channel enhancement-mode lateral field-effect RF power transistor designed for broadband commercial and industrial applications at frequencies up to 2.0 GHz. The LET20045C is designed for high gain and broadband performance operating in common source mode at 36 V. It is ideal for base station applications requiring high linearity.

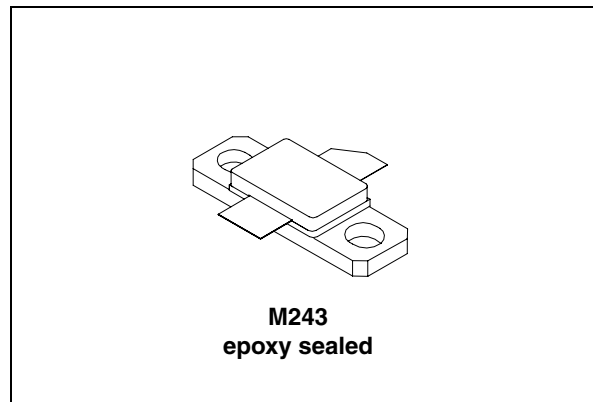

Figure 1. Pin out

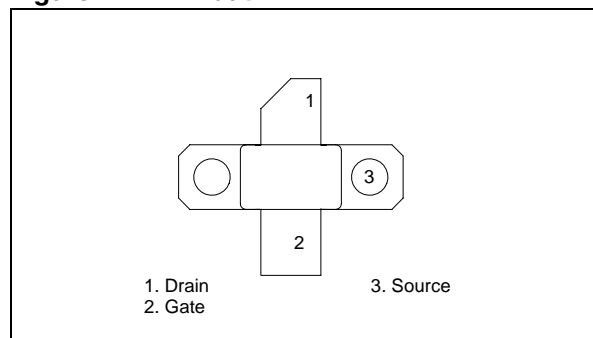

Table 1. Device summary

Order code	Package	Branding
LET20045C	M243	LET20045C

1 Maximum ratings

Table 2. Absolute maximum ratings ($T_{CASE} = 25\text{ °C}$)

Symbol	Parameter	Value	Unit
$V_{(BR)DSS}$	Drain-source voltage	80	V
V_{GS}	Gate-source voltage	-0.5 to +15	V
I_D	Drain current	12	A
P_{DISS}	Power dissipation (@ $T_C = 70\text{ °C}$)	130	W
T_J	Max. operating junction temperature	200	°C
T_{STG}	Storage temperature	-65 to +150	°C

Table 3. Thermal data

Symbol	Parameter	Value	Unit
$R_{th(JC)}$	Junction-case thermal resistance	1.0	°C/W

2 Electrical characteristics

$T_C = 25\text{ }^\circ\text{C}$

Table 4. Static

Symbol	Test conditions	Min.	Typ.	Max.	Unit
$V_{(BR)DSS}$	$V_{GS} = 0\text{ V}; I_{DS} = 10\text{ mA}$	80			V
I_{DSS}	$V_{GS} = 0\text{ V}; V_{DS} = 28\text{ V}$			1	μA
I_{GSS}	$V_{GS} = 5\text{ V}; V_{DS} = 0\text{ V}$			1	μA
$V_{GS(Q)}$	$V_{DS} = 28\text{ V}; I_D = 100\text{ mA}$	2.0		5.0	V
$V_{DS(ON)}$	$V_{GS} = 10\text{ V}; I_D = 3\text{ A}$		0.8	1.2	V
G_{FS}	$V_{DS} = 10\text{ V}; I_D = 3\text{ A}$	2.5			mho
C_{ISS}	$V_{GS} = 0\text{ V}; V_{DS} = 28\text{ V}; f = 1\text{ MHz}$		77		pF
C_{OSS}	$V_{GS} = 0\text{ V}; V_{DS} = 28\text{ V}; f = 1\text{ MHz}$		39		pF
C_{RSS}	$V_{GS} = 0\text{ V}; V_{DS} = 28\text{ V}; f = 1\text{ MHz}$		1.2		pF

Table 5. Dynamic

Symbol	Test conditions	Min.	Typ.	Max.	Unit
P_{OUT}	$V_{DD} = 28\text{ V}; I_{DQ} = 500\text{ mA}; P_{IN} = 2.5\text{ W}; f = 2000\text{ MHz}$	45	54	-	W
G_{PS}	$V_{DD} = 28\text{ V}; I_{DQ} = 500\text{ mA}; P_{IN} = 2.5\text{ W}; f = 2000\text{ MHz}$	12	13.3	-	dB
h_D	$V_{DD} = 28\text{ V}; I_{DQ} = 500\text{ mA}; P_{IN} = 2.5\text{ W}; f = 2000\text{ MHz}$	45	51	-	%
Load mismatch	$V_{DD} = 28\text{ V}; I_{DQ} = 500\text{ mA}; P_{IN} = 2.5\text{ W}; f = 2000\text{ MHz}$ All phase angles	10:1			VSWR

3 Impedance data

Figure 2. Impedance data

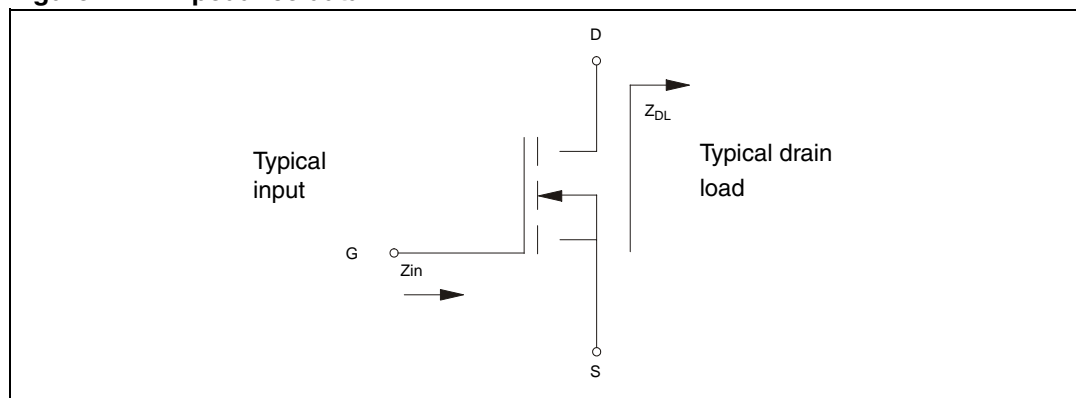
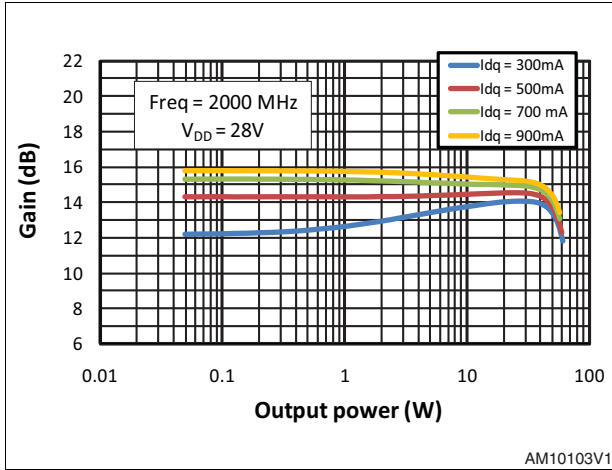

Table 6. Impedance data

Frequency	$Z_{IN} (\Omega)$	$Z_{DL} (\Omega)$
TBD	TBD	TBD

4 Typical performances

Figure 3. Gain vs output power and bias current



AM10103V1

Figure 4. Gain and efficiency vs output power

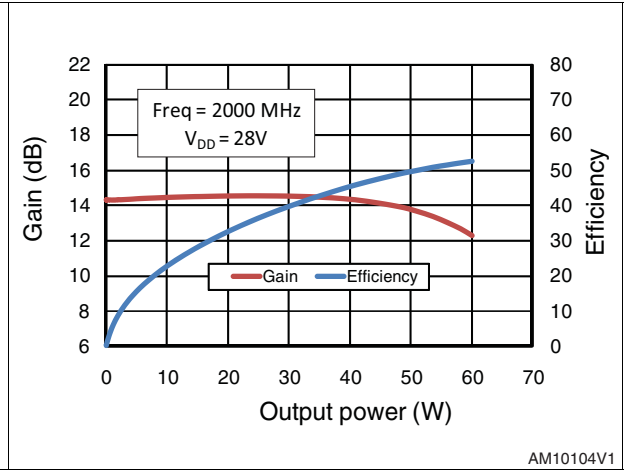

AM10104V1

Figure 5. Gain vs output power and supply voltage

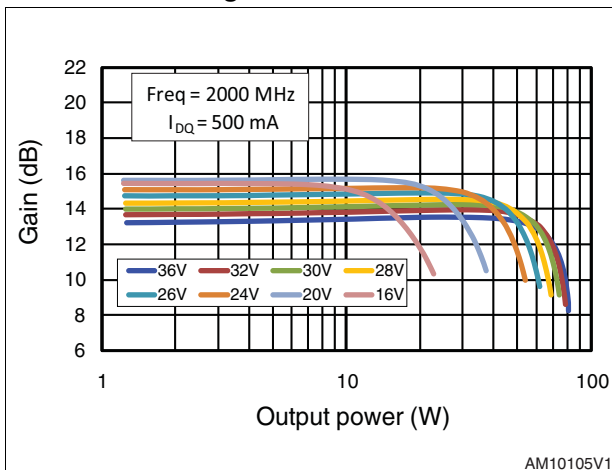

AM10105V1

Figure 6. Efficiency vs output power and supply voltage

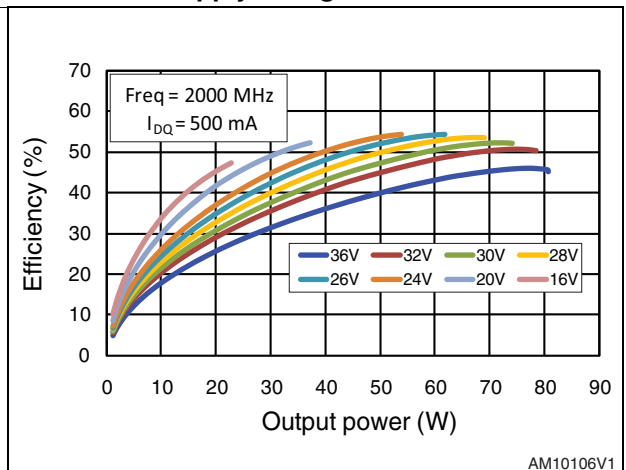

AM10106V1

Figure 7. IMD vs output power @ 28 V

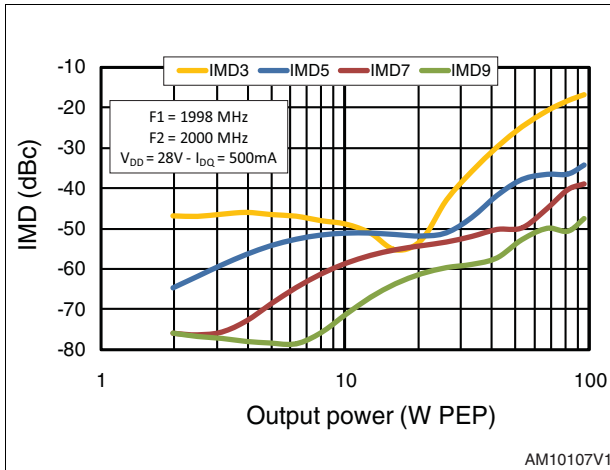

Figure 8. IMD vs output power @ 32 V

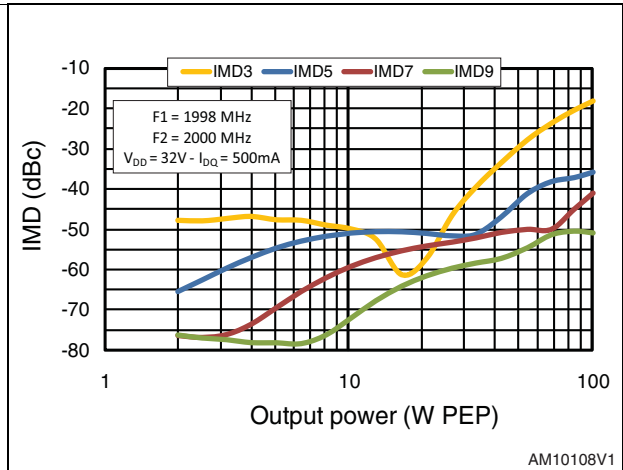

Figure 9. ACPR and efficiency vs output power @ 28 V

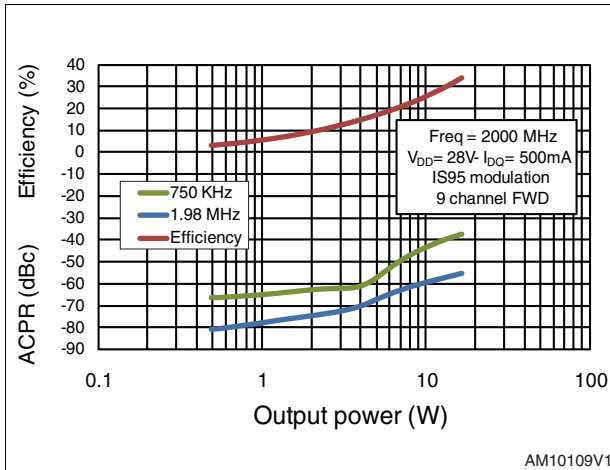
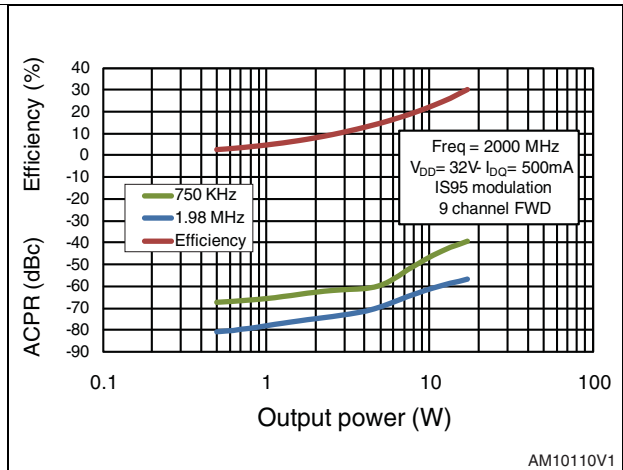

Figure 10. ACPR and efficiency vs output power @ 32 V



5 Package mechanical data

In order to meet environmental requirements, ST offers these devices in different grades of ECOPACK® packages, depending on their level of environmental compliance. ECOPACK® specifications, grade definitions and product status are available at: www.st.com. ECOPACK® is an ST trademark.

Table 7. M243 (.230 x .360 2L N/HERM W/FLG) mechanical data

Dim.	mm			inch		
	Min.	Typ	Max.	Min.	Typ	Max.
A	5.21		5.72	0.205		0.225
B	5.46		6.48	0.215		0.255
C	5.59		6.1	0.22		0.24
D		14.27			0.562	
E	20.07		20.57	0.79		0.81
F	8.89		9.4	0.35		0.37
G	0.1		0.15	0.004		0.006
H	3.18		4.45	0.125		0.175
I	1.83		2.24	0.072		0.088
J	1.27		1.78	0.05		0.07

Figure 11. M243 package dimensions

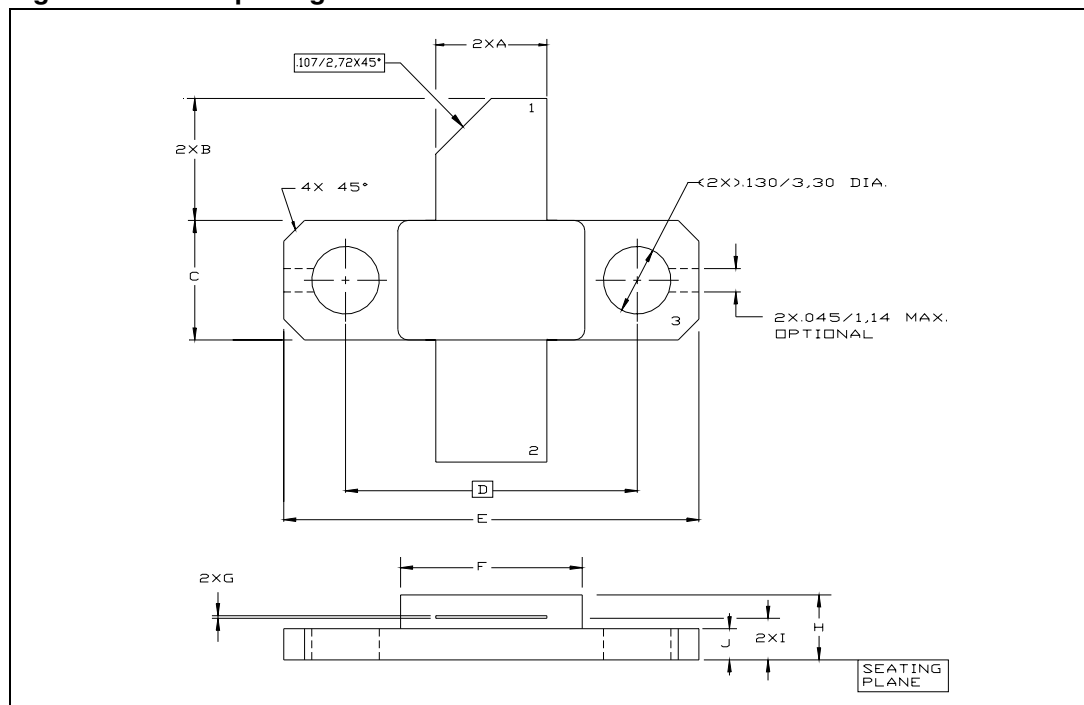

6 Revision history

Table 8. Document revision history

Date	Revision	Changes
19-Jul-2011	1	Initial release.

Please Read Carefully:

Information in this document is provided solely in connection with ST products. STMicroelectronics NV and its subsidiaries ("ST") reserve the right to make changes, corrections, modifications or improvements, to this document, and the products and services described herein at any time, without notice.

All ST products are sold pursuant to ST's terms and conditions of sale.

Purchasers are solely responsible for the choice, selection and use of the ST products and services described herein, and ST assumes no liability whatsoever relating to the choice, selection or use of the ST products and services described herein.

No license, express or implied, by estoppel or otherwise, to any intellectual property rights is granted under this document. If any part of this document refers to any third party products or services it shall not be deemed a license grant by ST for the use of such third party products or services, or any intellectual property contained therein or considered as a warranty covering the use in any manner whatsoever of such third party products or services or any intellectual property contained therein.

UNLESS OTHERWISE SET FORTH IN ST'S TERMS AND CONDITIONS OF SALE ST DISCLAIMS ANY EXPRESS OR IMPLIED WARRANTY WITH RESPECT TO THE USE AND/OR SALE OF ST PRODUCTS INCLUDING WITHOUT LIMITATION IMPLIED WARRANTIES OF MERCHANTABILITY, FITNESS FOR A PARTICULAR PURPOSE (AND THEIR EQUIVALENTS UNDER THE LAWS OF ANY JURISDICTION), OR INFRINGEMENT OF ANY PATENT, COPYRIGHT OR OTHER INTELLECTUAL PROPERTY RIGHT.

UNLESS EXPRESSLY APPROVED IN WRITING BY TWO AUTHORIZED ST REPRESENTATIVES, ST PRODUCTS ARE NOT RECOMMENDED, AUTHORIZED OR WARRANTED FOR USE IN MILITARY, AIR CRAFT, SPACE, LIFE SAVING, OR LIFE SUSTAINING APPLICATIONS, NOR IN PRODUCTS OR SYSTEMS WHERE FAILURE OR MALFUNCTION MAY RESULT IN PERSONAL INJURY, DEATH, OR SEVERE PROPERTY OR ENVIRONMENTAL DAMAGE. ST PRODUCTS WHICH ARE NOT SPECIFIED AS "AUTOMOTIVE GRADE" MAY ONLY BE USED IN AUTOMOTIVE APPLICATIONS AT USER'S OWN RISK.

Resale of ST products with provisions different from the statements and/or technical features set forth in this document shall immediately void any warranty granted by ST for the ST product or service described herein and shall not create or extend in any manner whatsoever, any liability of ST.

ST and the ST logo are trademarks or registered trademarks of ST in various countries.

Information in this document supersedes and replaces all information previously supplied.

The ST logo is a registered trademark of STMicroelectronics. All other names are the property of their respective owners.

© 2011 STMicroelectronics - All rights reserved

STMicroelectronics group of companies

Australia - Belgium - Brazil - Canada - China - Czech Republic - Finland - France - Germany - Hong Kong - India - Israel - Italy - Japan - Malaysia - Malta - Morocco - Philippines - Singapore - Spain - Sweden - Switzerland - United Kingdom - United States of America

www.st.com



X-ON Electronics

Largest Supplier of Electrical and Electronic Components

Click to view similar products for [RF MOSFET Transistors](#) category:

Click to view products by [STMicroelectronics](#) manufacturer:

Other Similar products are found below :

[MRF492](#) [MRFE8VP8600HR5](#) [ARF1511](#) [ARF465BG](#) [BF 2030 E6814](#) [BLF861A](#) [DU1215S](#) [DU28200M](#) [UF28100M](#) [DU2820S](#)
[MHT1008NT1](#) [MMRF1014NT1](#) [MRF426](#) [ARF468AG](#) [ARF468BG](#) [MAPHST0045](#) [DU2860U](#) [MRFE6VP5300NR1](#) [BF2040E6814HTSA1](#)
[MRFE6VP5150GNR1](#) [LET9060S](#) [MRF136Y](#) [BF999E6327HTSA1](#) [SD2931-12MR](#) [BF998E6327HTSA1](#) [AFV10700HR5](#) [MRF141](#) [MRF171](#)
[MRF172](#) [MRF174](#) [QPD1020SR](#) [BF 1005S E6327](#) [MRF134](#) [MRF136](#) [MRF137](#) [MRF141G](#) [MRF151A](#) [MRF151G](#) [MRF157](#) [MRF158](#)
[MRF160](#) [MRF171A](#) [MRF177](#) [UF2840G](#) [TGF3021-SM](#) [ARF1510](#) [ARF448BG](#) [ARF449AG](#) [ARF466BG](#) [VRF150](#)