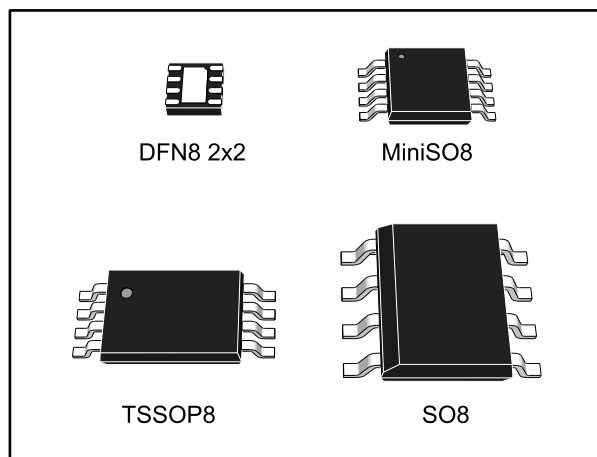

Low-power, dual-voltage comparators

Datasheet - production data

**Description**

The LM193, LM293, and LM393 devices consist of two independent low voltage comparators designed specifically to operate from a single supply over a wide range of voltages. Operation from split power supplies is also possible.

These comparators also have a unique characteristic in that the input common-mode voltage range includes ground even though operated from a single power supply voltage.

Features

- Wide single-supply voltage range or dual supplies: 2 V to 36 V or ± 1 V to ± 18 V
- Very low supply current (0.45 mA) independent of supply voltage (1 mW/comparator at 5 V)
- Low input bias current: 20 nA typ.
- Low input offset current: ± 3 nA typ.
- Low input offset voltage: ± 1 mV typ.
- Input common-mode voltage range includes ground
- Low output saturation voltage: 80 mV typ. ($I_{\text{sink}} = 4$ mA)
- Differential input voltage range equal to the supply voltage
- TTL, DTL, ECL, MOS, CMOS compatible outputs
- Available in DFN8 2x2, MiniSO8, TSSOP8, and SO8 packages

Contents

1 Schematic diagram..... 3

2 Package pin connections..... 4

3 Absolute maximum ratings and operating conditions 5

4 Electrical characteristics 7

5 Electrical characteristic curves 8

6 Typical applications 9

7 Package information 12

 7.1 DFN8 2x2 package information..... 13

 7.2 MiniSO8 package information 15

 7.3 TSSOP8 package information..... 16

 7.4 SO8 package information..... 17

8 Ordering information..... 18

9 Revision history 19

1 Schematic diagram

Figure 1: Schematic diagram (1/2 LM193)

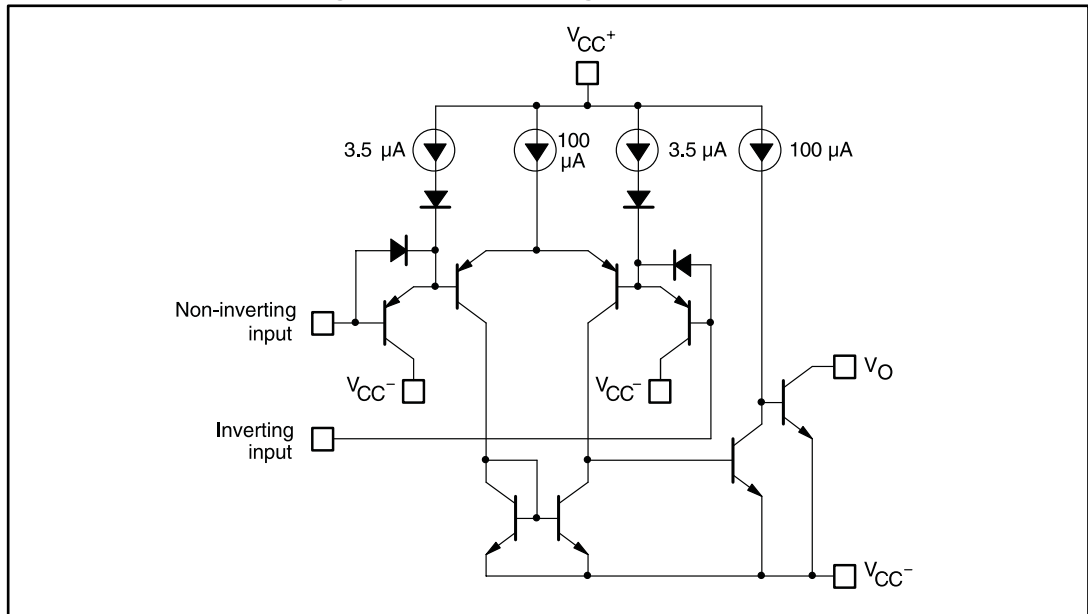

2 Package pin connections

Figure 2: Pin connections (top view)

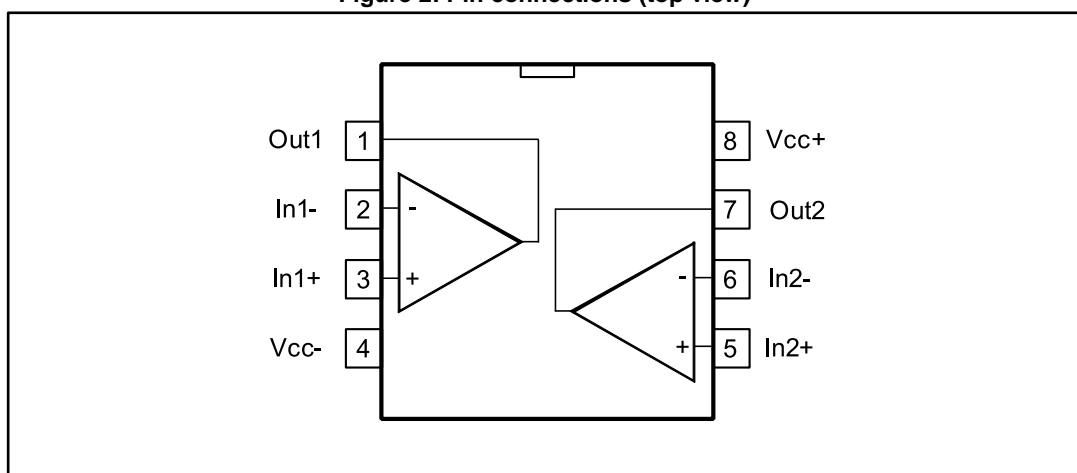

1. The exposed pad of the DFN8 2x2 can be left floating or connected to ground

3 Absolute maximum ratings and operating conditions

Table 1: Absolute maximum ratings

Symbol	Parameter	Value	Unit	
V_{CC}	Supply voltage	±18 or 36	V	
V_{id}	Differential input voltage	±36		
V_{in}	Input voltage	-0.3 to 36		
	Output short-circuit to ground ⁽¹⁾	Infinite		
R_{thja}	Thermal resistance junction to ambient ⁽²⁾	DFN8 2x2	57	°C/W
		MiniSO8	190	
		TSSOP8	120	
		SO8	125	
R_{thjc}	Thermal resistance junction to case ⁽²⁾	DFN8 2x2	—	
		MiniSO8	39	
		TSSOP8	37	
		SO8	40	
T_j	Maximum junction temperature	150	°C	
T_{stg}	Storage temperature range	-65 to 150		
ESD class ⁽³⁾	HBM: human body model ⁽⁴⁾	H1B		
	MM: machine model ⁽⁵⁾	M2		
	CDM: charged device model ⁽⁶⁾	C5		

Notes:

⁽¹⁾ Short-circuits from the output to V_{CC+} can cause excessive heating and potential destruction. The maximum output current is approximately 20 mA independent of the magnitude of V_{CC+} .

⁽²⁾ Short-circuits can cause excessive heating and destructive dissipation. Values are typical.

⁽³⁾ ESD class definition from AEC-Q100:

⁽⁴⁾ HBM class H1B: ESD voltage level from 500 V to 1000 V

⁽⁵⁾ MM class M2: ESD voltage level from 100 V to 200 V

⁽⁶⁾ CDM class C5: ESD voltage level greater than 1500 V.

Table 2: Operating conditions

Symbol	Parameter	Value	Unit	
V_{CC}	Supply voltage (V_{CC^+}) - (V_{CC^-})	2 to 36	V	
V_{icm}	Common mode input voltage range ($V_{CC^+} = 30\text{ V}$) ⁽¹⁾	$T_{amb} = 25\text{ °C}$ $T_{min} \leq T_{amb} \leq T_{max}$		$0\text{ to } (V_{CC^+}) - 1.5$ $0\text{ to } (V_{CC^+}) - 2$
T_{oper}	Operating free-air temperature range	LM193, LM193A LM293, LM293A LM393, LM393A	-55 to 125 -40 to 105 0 to 70	°C

Notes:

⁽¹⁾The input common-mode voltage of either input signal voltage should not be allowed to go negative by more than 0.3 V. The high end of the common-mode voltage range is (V_{CC^+}) - 1.5 V, but either or both inputs can go to 30 V without damage.

4 Electrical characteristics

Table 3: $V_{CC+} = 5\text{ V}$, $V_{CC-} = 0\text{ V}$, $T_{amb} = 25\text{ }^{\circ}\text{C}$ (unless otherwise specified)

Symbol	Parameter	Condition	LM193A, LM293A, LM393A			LM193, LM293, LM393			Unit
			Min.	Typ.	Max.	Min	Typ.	Max.	
V_{io}	Input offset voltage ⁽¹⁾			1	2		1	5	mV
		$T_{min} \leq T_{amb} \leq T_{max}$			4			9	
I_{io}	Input offset current			3	25		3	50	nA
		$T_{min} \leq T_{amb} \leq T_{max}$			100			150	
I_{ib}	Input bias current (I^+ or I^-) ⁽²⁾			20	100		20	250	nA
		$T_{min} \leq T_{amb} \leq T_{max}$			300			400	
A_{vd}	Large signal voltage gain	$V_{CC} = 15\text{ V}$, $R_L = 15\text{ k}\Omega$, $V_o = 1\text{ V}$ to 11 V	50	200		50	200		V/mV
I_{CC}	Supply current (all comparators)	$V_{CC} = 5\text{ V}$, no load		0.45	1		0.45	1	mA
		$V_{CC} = 30\text{ V}$, no load		0.6	2.5		0.6	2.5	
V_{id}	Differential input voltage ⁽³⁾				V_{CC}^+			V_{CC}^+	
V_{OL}	Low-level output voltage	$V_{id} = -1\text{ V}$, $I_{sink} = 4\text{ mA}$		80	400		80	400	mV
		$T_{min} \leq T_{amb} \leq T_{max}$			700			700	
I_{OH}	High-level output current	$V_{CC} = V_o = 30\text{ V}$, $V_{id} = 1\text{ V}$		0.1			0.1		nA
		$T_{min} \leq T_{amb} \leq T_{max}$			1			1	μA
I_{sink}	Output sink current	$V_{id} = 1\text{ V}$, $V_o = 1.5\text{ V}$	6	18		6	18		mA
t_{re}	Response time ⁽⁴⁾	$R_L = 5.1\text{ k}\Omega$ connected to V_{CC}^+		1.3			1.3		μs
t_{rel}	Large signal response time	$R_L = 5.1\text{ k}\Omega$ connected to V_{CC}^+ , $e_l = \text{TTL}$, $V_{(ref)} = 1.4\text{ V}$		300			300		ns

Notes:

⁽¹⁾ At output switch point, $V_o = 1.4\text{ V}$, $R_s = 0$ with V_{CC}^+ from 5 V to 30 V , and over the full common-mode range (0 V to $(V_{CC}^+) - 1.5\text{ V}$).

⁽²⁾ The direction of the input current is out of the IC due to the PNP input stage. This current is essentially constant, independent of the state of the output, so no loading charge exists on the reference of input lines.

⁽³⁾ Positive excursions of input voltage may exceed the power supply level. As long as the other voltage remains within the common-mode range, the comparator will provide a proper output state. The low input voltage state must not be less than -0.3 V (or 0.3 V below the negative power supply, if used).

⁽⁴⁾ The response time specified is for a 100 mV input step with 5 mV overdrive. For larger overdrive signals, 300 ns can be obtained.

5 Electrical characteristic curves

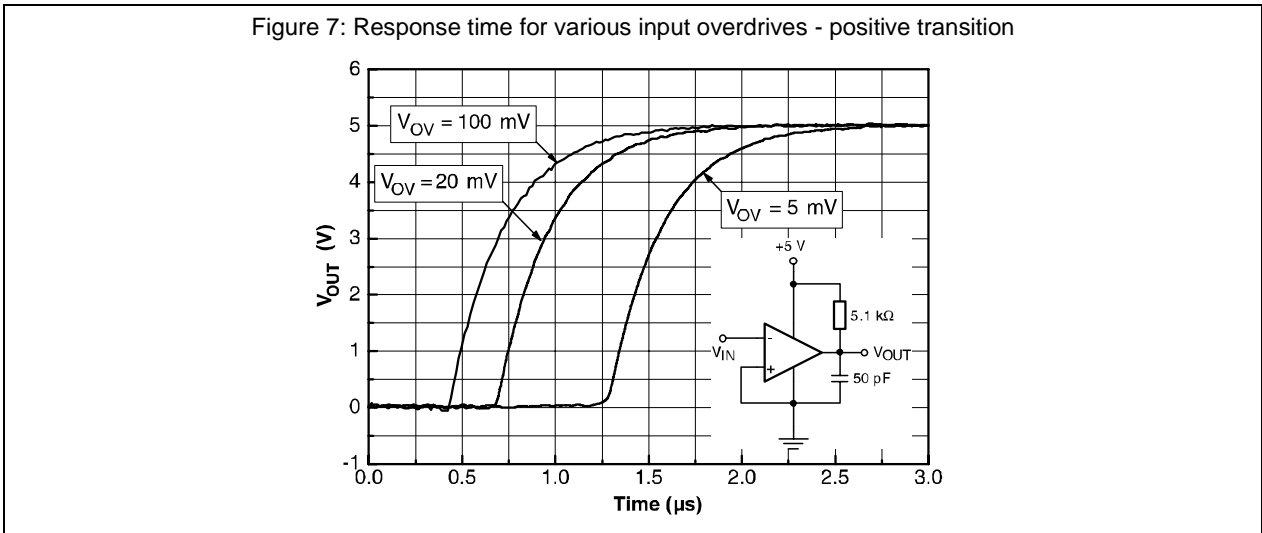
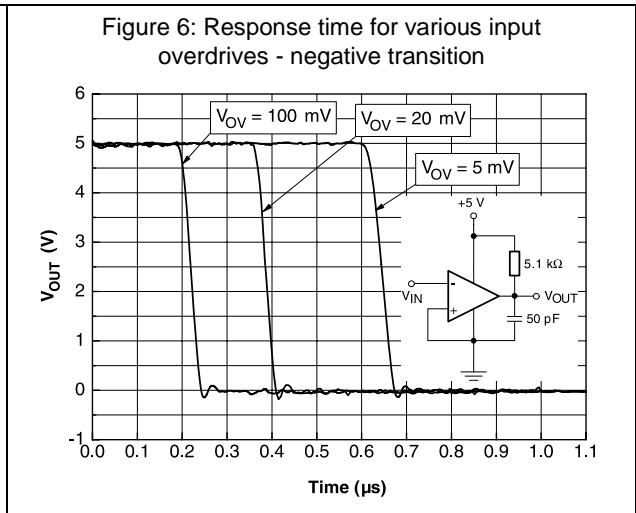
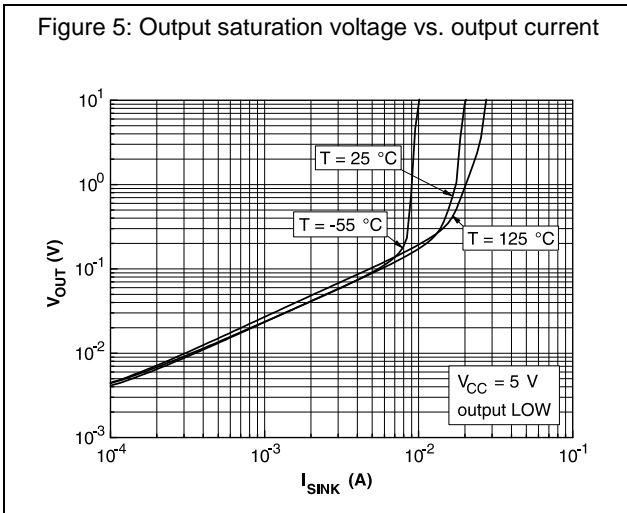
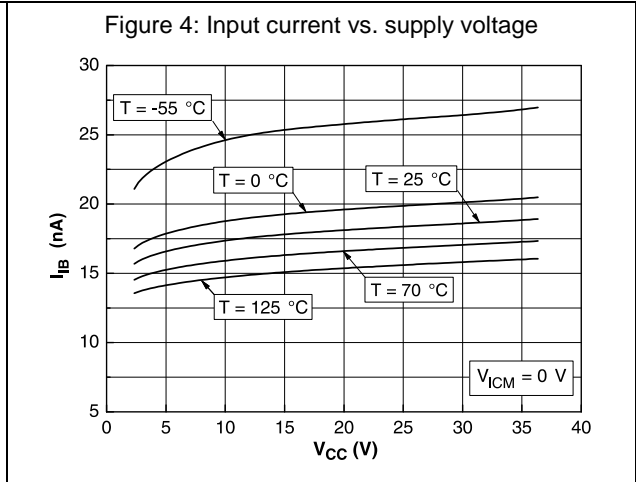
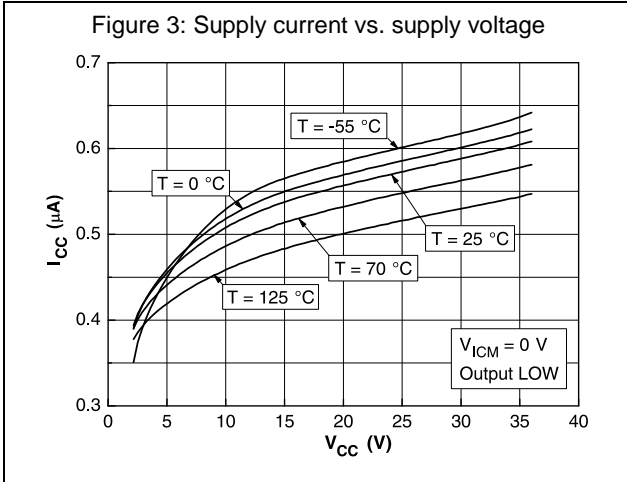

6 Typical applications

Figure 8: Basic comparator

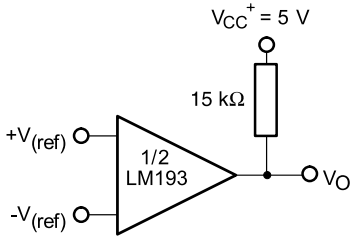

Figure 9: Driving TTL

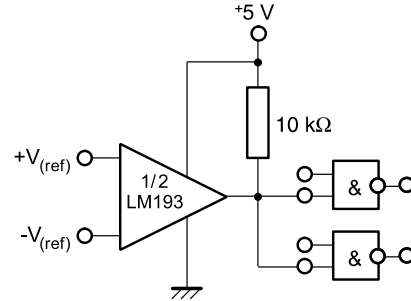

Figure 10: Low-frequency op amp (1)

($e_o = 0$ V for $e_i = 0$ V)

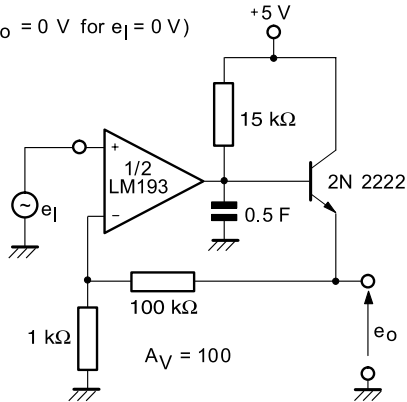

Figure 11: Driving CMOS

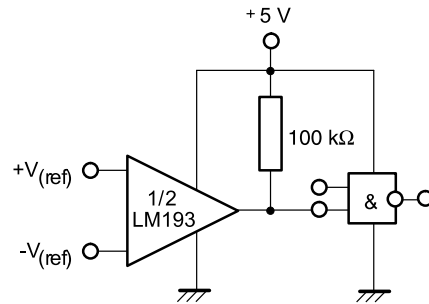

Figure 12: Low-frequency op amp (2)

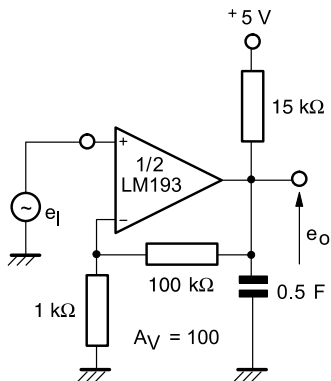
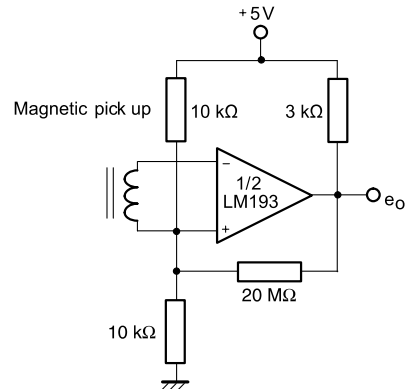

Figure 13: Transducer amplifier



Typical applications

LM193, LM293, LM393

Figure 14: Low-frequency op amp with offset adjust

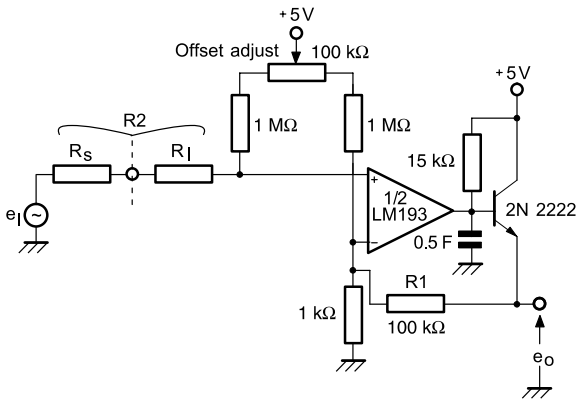

Figure 15: Zero crossing detector (single power supply)

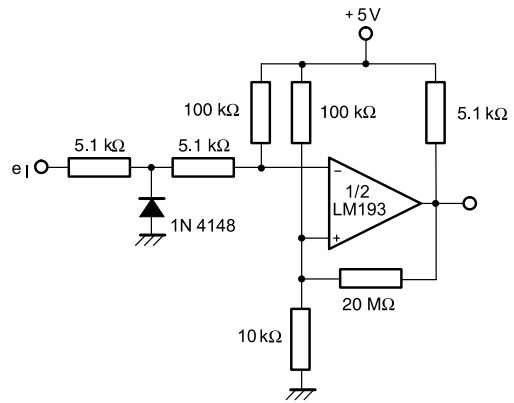

Figure 16: Limit comparator

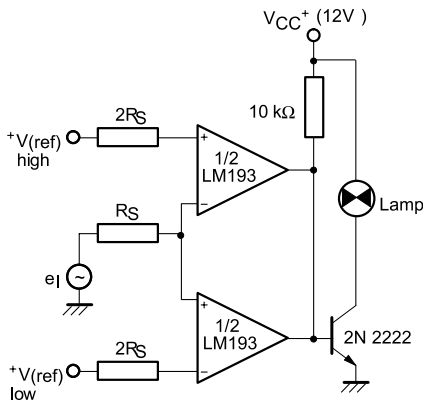

Figure 17: Crystal controlled comparator

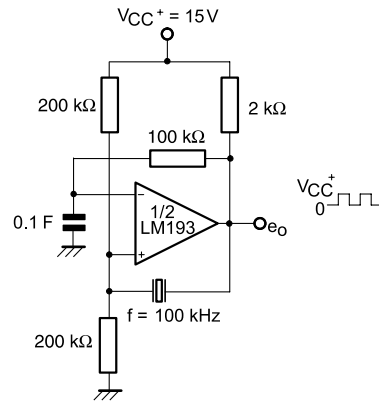

Figure 18: Split supply applications (zero crossing detector)

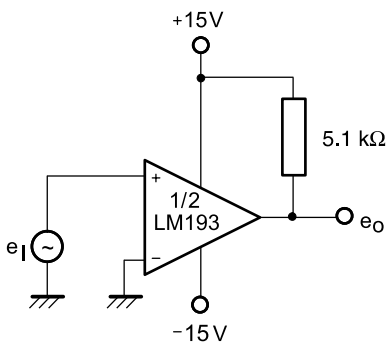

Figure 19: Comparator with a negative reference

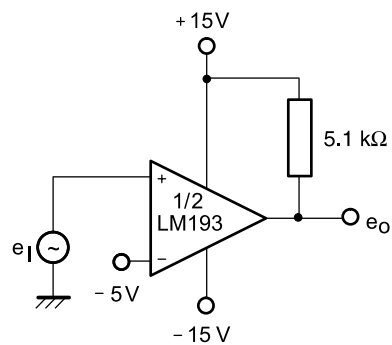
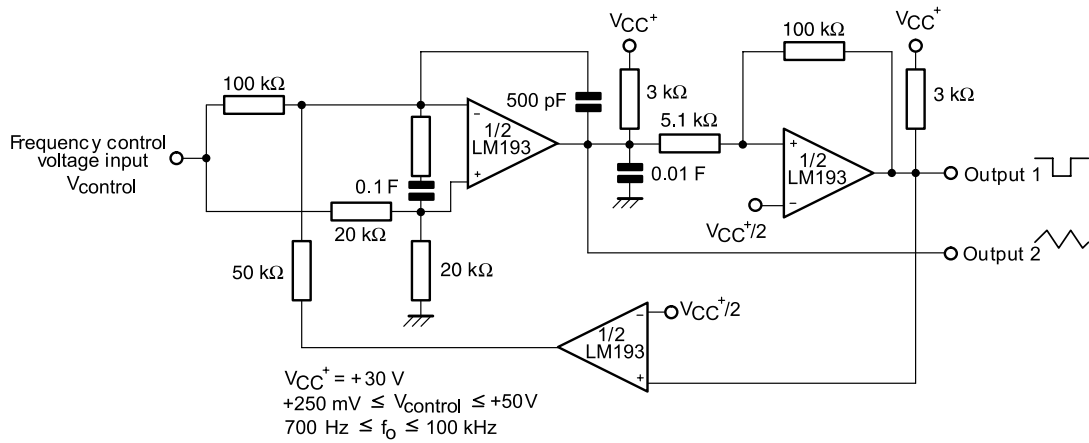

Figure 20: Two-decade, high-frequency VCO



7 Package information

In order to meet environmental requirements, ST offers these devices in different grades of ECOPACK[®] packages, depending on their level of environmental compliance. ECOPACK[®] specifications, grade definitions and product status are available at: www.st.com. ECOPACK[®] is an ST trademark.

7.1 DFN8 2x2 package information

Figure 21: DFN8 2x2 package outline

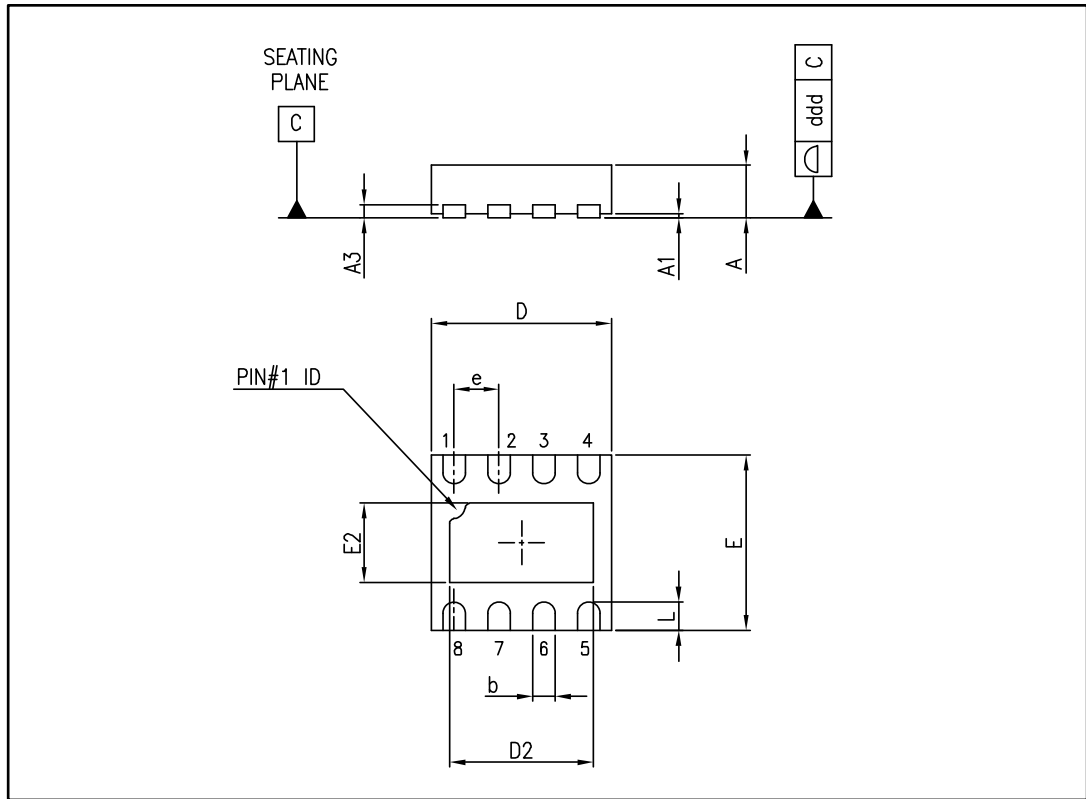
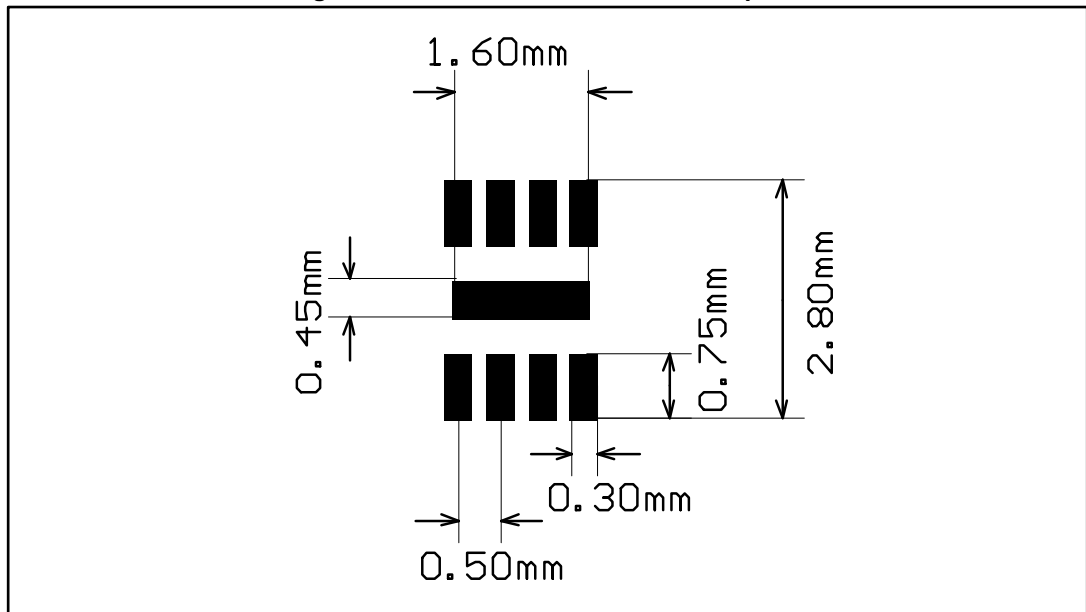

Table 4: DFN8 2x2 mechanical data

Ref.	Dimensions					
	Millimeters			Inches		
	Min.	Typ.	Max.	Min.	Typ.	Max.
A	0.51	0.55	0.60	0.020	0.022	0.024
A1			0.05			0.002
A3		0.15			0.006	
b	0.18	0.25	0.30	0.007	0.010	0.012
D	1.85	2.00	2.15	0.073	0.079	0.085
D2	1.45	1.60	1.70	0.057	0.063	0.067
E	1.85	2.00	2.15	0.073	0.079	0.085
E2	0.75	0.90	1.00	0.030	0.035	0.039
e		0.50			0.020	
L			0.425			0.017
ddd			0.08			0.003

Figure 22: DFN8 2x2 recommended footprint



7.2 MiniSO8 package information

Figure 23: MiniSO8 package outline

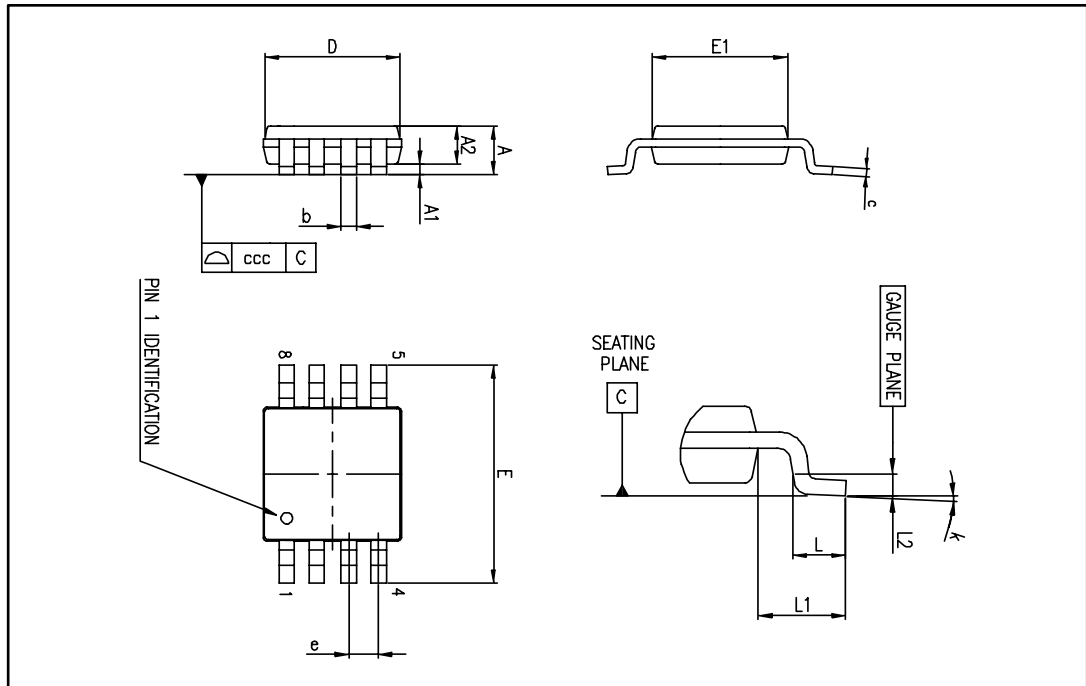

Table 5: MiniSO8 mechanical data

Ref.	Dimensions					
	Millimeters			Inches		
	Min.	Typ.	Max.	Min.	Typ.	Max.
A			1.1			0.043
A1	0		0.15	0		0.006
A2	0.75	0.85	0.95	0.030	0.033	0.037
b	0.22		0.40	0.009		0.016
c	0.08		0.23	0.003		0.009
D	2.80	3.00	3.20	0.11	0.118	0.126
E	4.65	4.90	5.15	0.183	0.193	0.203
E1	2.80	3.00	3.10	0.11	0.118	0.122
e		0.65			0.026	
L	0.40	0.60	0.80	0.016	0.024	0.031
L1		0.95			0.037	
L2		0.25			0.010	
k	0°		8°	0°		8°
ccc			0.10			0.004

7.3 TSSOP8 package information

Figure 24: TSSOP8 package outline

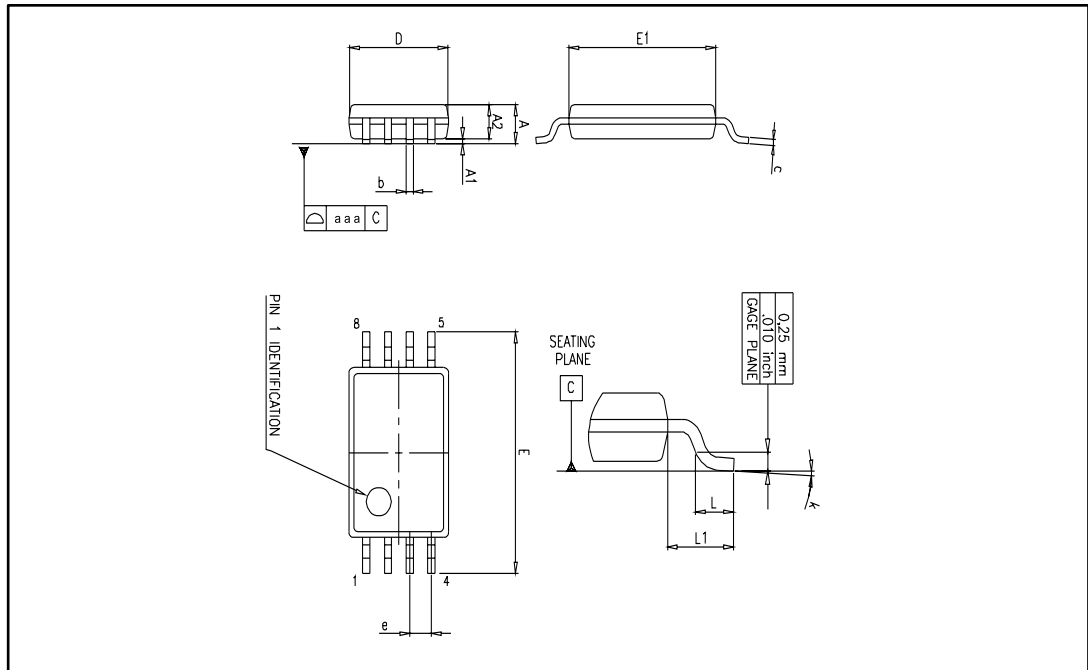

Table 6: TSSOP8 mechanical data

Ref.	Dimensions					
	Millimeters			Inches		
	Min.	Typ.	Max.	Min.	Typ.	Max.
A			1.2			0.047
A1	0.05		0.15	0.002		0.006
A2	0.80	1.00	1.05	0.031	0.039	0.041
b	0.19		0.30	0.007		0.012
c	0.09		0.20	0.004		0.008
D	2.90	3.00	3.10	0.114	0.118	0.122
E	6.20	6.40	6.60	0.244	0.252	0.260
E1	4.30	4.40	4.50	0.169	0.173	0.177
e		0.65			0.0256	
k	0°		8°	0°		8°
L	0.45	0.60	0.75	0.018	0.024	0.030
L1		1			0.039	
aaa		0.1			0.004	

7.4 SO8 package information

Figure 25: SO8 package outline

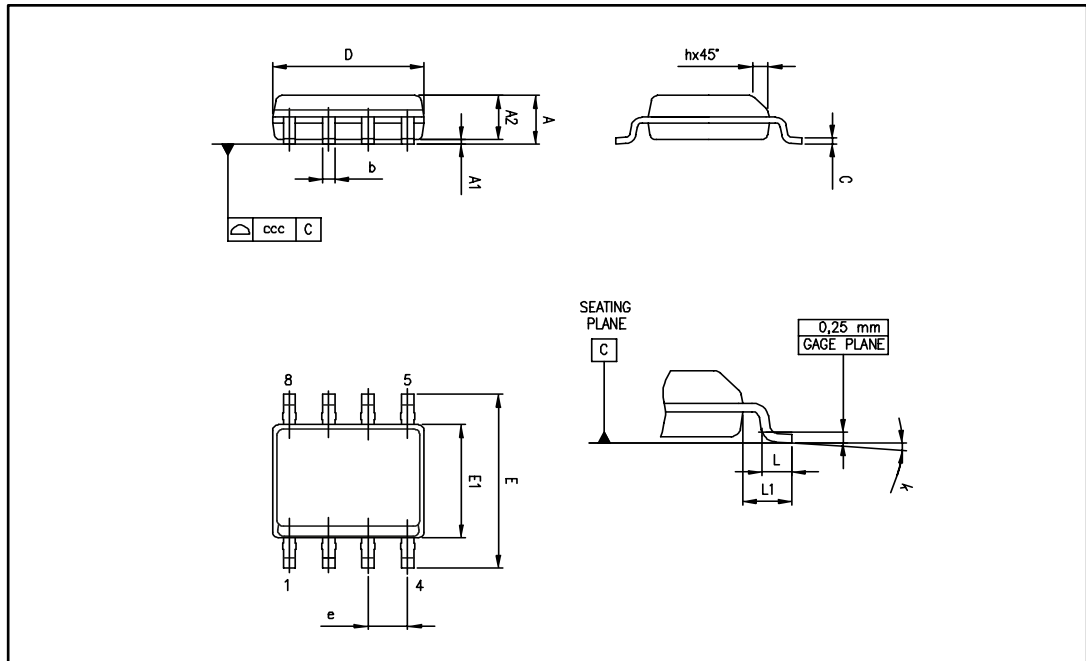

Table 7: SO8 mechanical data

Ref.	Dimensions					
	Millimeters			Inches		
	Min.	Typ.	Max.	Min.	Typ.	Max
A			1.75			0.069
A1	0.10		0.25	0.004		0.010
A2	1.25			0.049		
b	0.28		0.48	0.011		0.019
c	0.17		0.23	0.007		0.010
D	4.80	4.90	5.00	0.189	0.193	0.197
E	5.80	6.00	6.20	0.228	0.236	0.244
E1	3.80	3.90	4.00	0.150	0.154	0.157
e		1.27			0.050	
h	0.25		0.50	0.010		0.020
L	0.40		1.27	0.016		0.050
L1		1.04			0.040	
k	1°		8°	1°		8°
ccc			0.10			0.004

8 Ordering information

Table 8: Order codes

Order code	Temperature range	Package	Packing	Marking		
LM193ADT ⁽¹⁾	-55 °C to 125 °C	SO8	Tube or tape and reel	193A		
LM193DT				193		
LM293ADT	-40 °C to 105 °C			TSSOP8	Tape and reel	293A
LM293D						293
LM293DT			MiniSO8	Tape and reel	K512	
LM293PT					K59	
LM293ST	0 °C to 70 °C		DFN8 2x2	Tube or tape and reel	393A	
LM293QT					393	
LM393ADT		TSSOP8	Tape and reel	M393		
LM393D					DFN8 2x2	K5B
LM393DT						
LM393PT						
LM393ST						
LM393QT						

Notes:

⁽¹⁾Not recommended for new design (NRND)

9 Revision history

Table 9: Document revision history

Date	Revision	Changes
02-Jul-2002	1	First release.
02-Jan-2005	2	Class A of the product included in the datasheet.
02-May-2005	3	PPAP references inserted in the datasheet, see Table 7: Ordering information on page 18.
02-Jul-2005	4	Modification on PPAP references - Errors on part numbers, see Table 7: Ordering information on page 18.
22-Nov-2005	5	Modification on Table 3 on page 6. LM293,A must be -40/+105°C instead of -40/+125°C.
16-Feb-2006	6	Unit error for V_{ol} parameter see Table 3 on page 6.
23-Aug-2007	7	Corrected error in DIP8 package information related to lead thickness, see Figure 21 on page 12. Added values for R_{thja} and R_{thjc} , and ESD parameters in Table 1: Absolute maximum ratings.
08-Nov-2007	8	Updated MiniSO-8 package information. Reformatted package information. Added automotive grade order codes.
19-Feb-2008	9	Corrected error in SO-8 package mechanical data: E dimension in drawing was marked with an F in table.
15-Dec-2008	10	Corrected heading in Figure 5.
22-Feb-2010	11	Deleted automotive grade order codes for LM293 and LM393.
22-Jun-2011	12	Updated typical performance curves. Updated typical values on Table 3 on page 6. Updated ESD parameters with ESD classes in Table 1: Absolute maximum ratings. Added DFN8 2x2mm package mechanical drawing. Added DFN8 2x2mm recommended footprint. Added DFN8 2x2mm order codes in Table 9.
27-Jun-2012	13	Updated Features (added package information), Description (added RPNs), Figure 1: Pin connections (top view) moved to page 3, added Contents, updated marking of the LM293QT device in Table 9, minor text corrections throughout document.
18-Jan-2013	14	Updated Table 8 (added dimensions in inches).

Date	Revision	Changes
09-Feb-2016	15	<p>Updated document layout Removed DIP8 package</p> <p><i>Features:</i> removed “plastic micropackage” from the DFN8 2x2, MiniSO8, and SO8 silhouettes; removed “thin shrink small outline package” from the TSSOP8 silhouette.</p> <p><i>Figure 2:</i> added footnote about the exposed pad of the DFN8 2x2</p> <p><i>Table 4:</i> updated “L” value</p> <p><i>Table 6:</i> “aaa” value is a typ. value not a max. value</p> <p><i>Table 7:</i> updated min. “k” millimeters value</p> <p><i>Table 8:</i> removed following obsolete order codes: LM193AD, LM193D, LM193AN, LM193N, LM293AD, LM293AN, LM293N, LM393AD, LM393AN, LM393N; added footnote (not recommended for new design) to order code LM193ADT; replaced marking of LM393QT with “K5B” instead of “K5C”.</p>

IMPORTANT NOTICE – PLEASE READ CAREFULLY

STMicroelectronics NV and its subsidiaries ("ST") reserve the right to make changes, corrections, enhancements, modifications, and improvements to ST products and/or to this document at any time without notice. Purchasers should obtain the latest relevant information on ST products before placing orders. ST products are sold pursuant to ST's terms and conditions of sale in place at the time of order acknowledgement.

Purchasers are solely responsible for the choice, selection, and use of ST products and ST assumes no liability for application assistance or the design of Purchasers' products.

No license, express or implied, to any intellectual property right is granted by ST herein.

Resale of ST products with provisions different from the information set forth herein shall void any warranty granted by ST for such product.

ST and the ST logo are trademarks of ST. All other product or service names are the property of their respective owners.

Information in this document supersedes and replaces information previously supplied in any prior versions of this document.

© 2016 STMicroelectronics – All rights reserved

X-ON Electronics

Largest Supplier of Electrical and Electronic Components

Click to view similar products for [Analog Comparators](#) category:

Click to view products by [STMicroelectronics](#) manufacturer:

Other Similar products are found below :

[633740E](#) [ADCMP396ARZ-RL7](#) [NCV2200SN2T1G](#) [NCV2200SQ2T2G](#) [SC339DR2G](#) [LM2901SNG](#) [LM339SNG](#) [AP393AM8G-13](#)
[418524AB](#) [TS393CD C3](#) [LM393SNG](#) [55122](#) [5962-8757203IA](#) [MAX971ESA+T](#) [MAX961ESAT](#) [MAX944ESD+T](#) [MAX931ESAT](#)
[MAX984CPE](#) [MAX9062EBSTG45](#) [MAX9041AEUTT](#) [MAX9022ASAT](#) [RT2902YDT](#) [M38510/11201B2A](#) [NTE911](#) [5962-8751601DA](#)
[5962-8751601CA](#) [MAX961EUA+T](#) [MAX9065EBS+TG45](#) [NCV2202SN2T1G](#) [MAX919ESA+T](#) [LT6700HS6-2#TRMPBF](#) [MAX19005CCS+](#)
[LM339EDR2G](#) [LT6700HS6-2#TRM](#) [NTE919](#) [NTE922](#) [TS883IQ2T](#) [LT6700HVCS6-3#TRMPBF](#) [LT6700HVHS6-3#TRMPBF](#)
[MAX978EEE+T](#) [MAX975ESA+T](#) [MAX9602EUG+T](#) [MAX997EUA+T](#) [MIC841NYC5-T5](#) [LM393WDT](#) [MCP6564T-E/STVAO](#)
[MAX983ESA+T](#) [NCX2200GMAZ](#) [LTC1540CMS8#PBF](#) [MC10E1651FNG](#)