



LM101A-LM201A LM301A

SINGLE OPERATIONAL AMPLIFIERS

	LM101A LM201A	LM301A
■ INPUT OFFSET VOLTAGE	0.7mV	2mV
■ INPUT BIAS CURRENT	25nA	70nA
■ INPUT OFFSET CURRENT	1.5nA	2nA
■ SLEW RATE AS INVERSING AMPLIFIER	10V/μs	10V/μs

DESCRIPTION

The LM101A is a general purpose operational amplifier which offers many features: supply voltages from $\pm 5V$ to $\pm 22V$, low current drain, overload protection on the input and output, no latch-up when the common-mode range is exceeded, free from oscillations and compensation with a single 30pF capacitor. It has advantages over internally compensated amplifiers in that the compensation can be tailored to the particular application: slew rate of 10V/μs and bandwidth of 3.5MHz can be easily achieved.

ORDER CODE

Part Number	Temperature Range	Package	
		N	D
LM101A	-55°C, +125°C	•	•
LM201A	-40°C, +105°C	•	•
LM301A	0°C, +70°C	•	•
Example : LM201AN			

N = Dual in Line Package (DIP)

D = Small Outline Package (SO) - also available in Tape & Reel (DT)

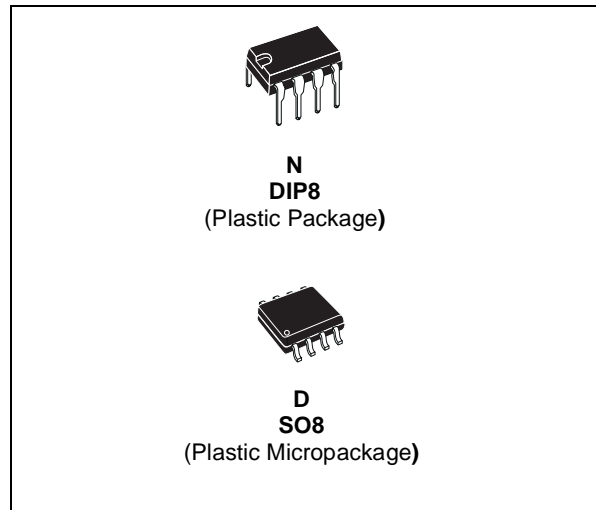

PIN CONNECTIONS (top view)

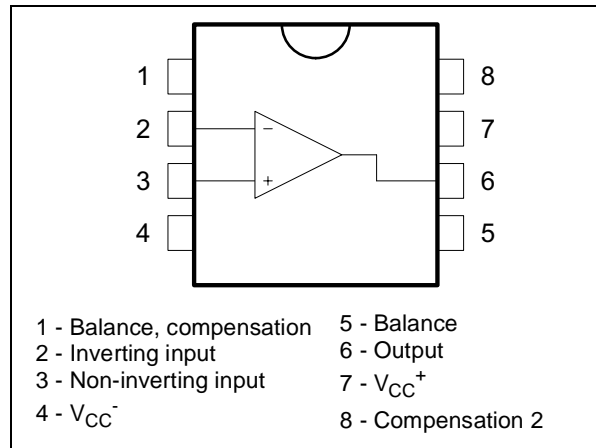

SCHEMATIC DIAGRAM

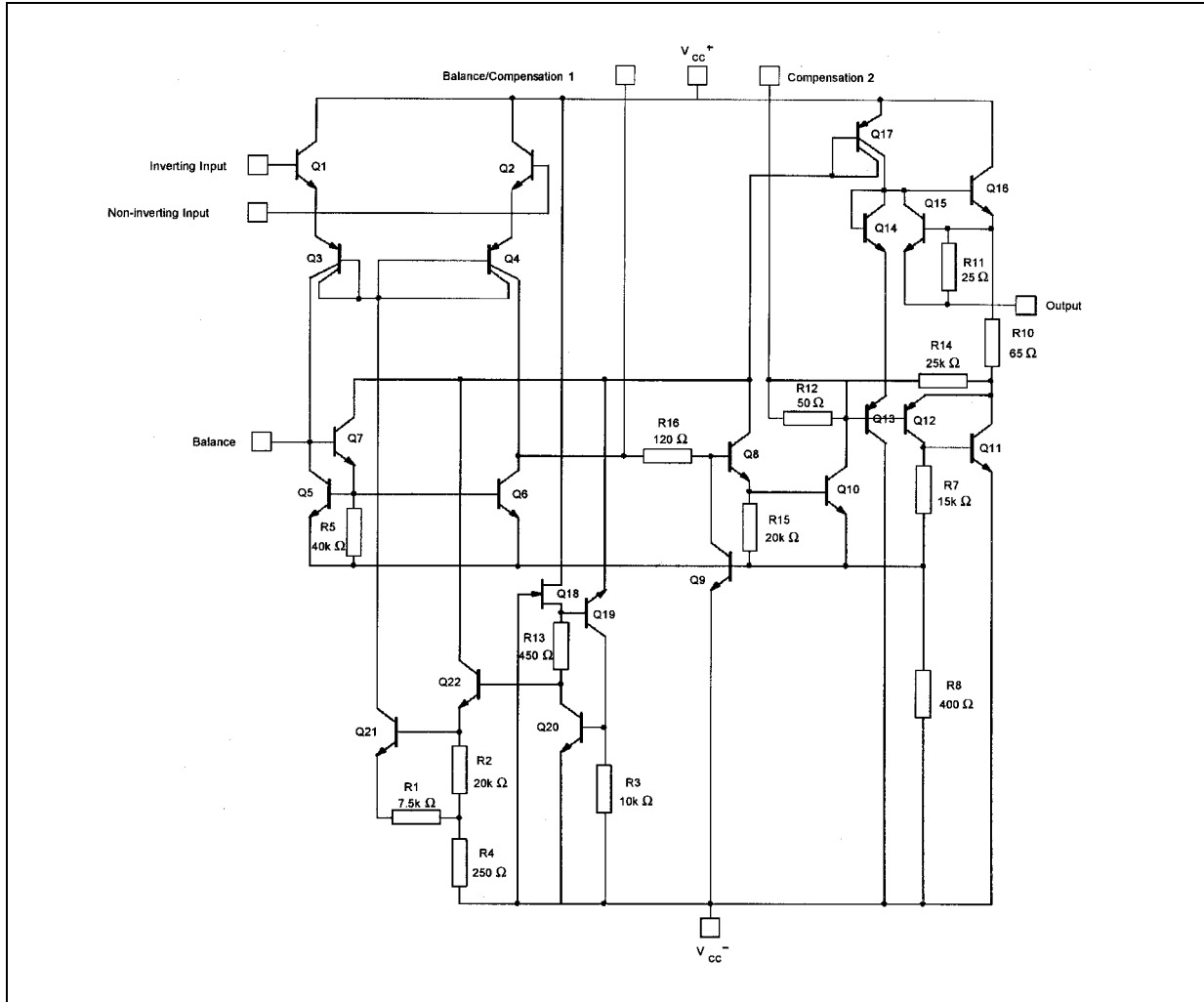

ABSOLUTE MAXIMUM RATINGS

Symbol	Parameter	LM101A	LM201A	LM301A	Unit
V_{CC}	Supply voltage	±22			V
V_i	Input Voltage	±15			V
V_{id}	Differential Input Voltage	±30			V
P_{tot}	Power Dissipation	N Suffix D Suffix			mW
	Output Short-circuit Duration	Infinite			
T_{oper}	Operating Free-air Temperature Range	-55 to +125	-40 to +105	0 to +70	°C
T_{stg}	Storage Temperature Range	-65 to +150			°C

ELECTRICAL CHARACTERISTICS $\pm 5V \leq V_{CC} \leq \pm 20V$, $C_1 = 30pF$, $T_{amb} = 25^\circ C$ (unless otherwise specified)

Symbol	Parameter	LM101A - LM201A			LM301A			Unit
		Min.	Typ.	Max.	Min.	Typ.	Max.	
V_{io}	Input Offset Voltage ($R_S \leq 10k\Omega$) $T_{amb} = +25^\circ C$ $T_{min} \leq T_{amb} \leq T_{max}$		0.7	2 3		2 7.5 10		mV
DV_{io}	Input Offset Voltage Drift $T_{min} \leq T_{amb} \leq T_{max}$		3	15		6 30		$\mu V/^\circ C$
I_{ib}	Input Bias Current - note $T_{amb} = +25^\circ C$ $T_{min} \leq T_{amb} \leq T_{max}$		25	75 100		70 250 300		nA
I_{io}	Input Offset Current $T_{amb} = +25^\circ C$ $T_{min} \leq T_{amb} \leq T_{max}$		1.5	10 20		2 50 70		nA
DI_{io}	Input Offset Current Drift $T_{min} \leq T_{amb} \leq 25^\circ C$ $T_{min} \leq T_{amb} \leq T_{max}$		10 20	100 200		10 20 300 600		$\mu A/^\circ C$
A_{vd}	Large Signal Voltage Gain * $V_O \leq 10V$, $R_L = 2k\Omega$ $T_{amb} = +25^\circ C$ $T_{min} \leq T_{amb} \leq T_{max}$	50 25	100		25 15	100		V/mV
SVR	Supply Voltage Rejection Ratio ($R_S \leq 10k\Omega$) $T_{amb} = +25^\circ C$ $T_{min} \leq T_{amb} \leq T_{max}$	80 80	96		70 70	96		dB
I_{CC}	Supply Current, no load $T_{amb} = +25^\circ C$ $T_{min} \leq T_{amb} \leq T_{max}$		1.8	3 3		1.8 3 3		mA
V_{icm}	Input Common Mode Voltage Range ($V_{CC} = \pm 20V$) $T_{amb} = +25^\circ C$ $T_{min} \leq T_{amb} \leq T_{max}$	± 15 ± 15			± 15 ± 15			V
CMR	Common Mode Rejection Ratio ($R_S \leq 10k\Omega$) $T_{amb} = +25^\circ C$ $T_{min} \leq T_{amb} \leq T_{max}$	80 80	96		70 70	96		dB
I_{OS}	Output Short-circuit Current * $T_{amb} = +25^\circ C$	10	30	50	10	30	50	mA
$\pm V_{OPP}$	Output Voltage Swing * $T_{amb} = +25^\circ C$ $T_{min} \leq T_{amb} \leq T_{max}$		$R_L = 10k\Omega$ 12 $R_L = 2k\Omega$ 10 13 $R_L = 10k\Omega$ 12 $R_L = 2k\Omega$ 10			$R_L = 10k\Omega$ 12 14 $R_L = 2k\Omega$ 10 13		V
SR	Slew Rate ($V_i = \pm 10V$, $R_L = 2k\Omega$, $C_L = 100pF$, unity gain) - ¹⁾	0.25	0.5		0.25	0.5		V/ μs

Symbol	Parameter	LM101A - LM201A			LM301A			Unit
		Min.	Typ.	Max.	Min.	Typ.	Max.	
t_r	Rise ($V_i = \pm 20\text{mV}$, $R_L = 2\text{k}\Omega$, $C_L = 100\text{pF}$, unity gain)		0.3			0.3		μs
K_{OV}	Overshoot ($V_i = 20\text{mV}$, $R_L = 2\text{k}\Omega$, $C_L = 100\text{pF}$, unity gain)		5			5		%
Z_i	Input Impedance *	1.5	4		1.5	4		$\text{M}\Omega$
GBP	Gain Bandwidth Product * ($V_i = 10\text{mV}$, $R_L = 2\text{k}\Omega$, $C_L = 100\text{pF}$, $f = 100\text{KHz}$)	0.5	1		0.5	1		MHz
THD	Total Harmonic Distortion ($f = 1\text{kHz}$, $A_v = 20\text{dB}$, $R_L = 2\text{k}\Omega$, $V_o = 2V_{pp}$, $C_L = 100\text{pF}$)		0.015			0.015		%
e_n	Equivalent Input Noise Voltage $f = 1\text{kHz}$, $R_s = 100\Omega$		25			25		$\frac{\text{nV}}{\sqrt{\text{Hz}}}$

1. May be improved up to $10\text{V}/\mu\text{s}$ in inverting amplifier configuration

* ==> $V_{CC} = \pm 15\text{V}$, $T_{amb} = +25^\circ\text{C}$ (unless otherwise specified)

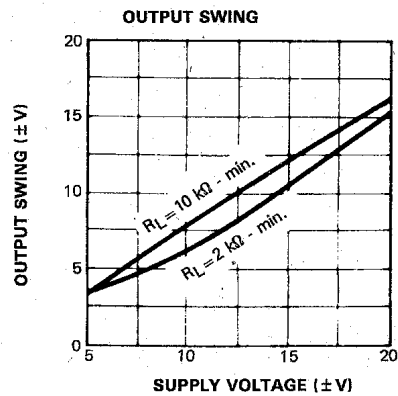
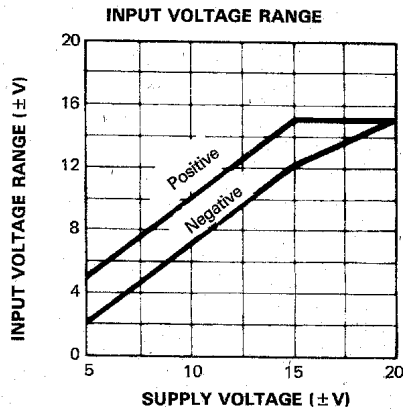

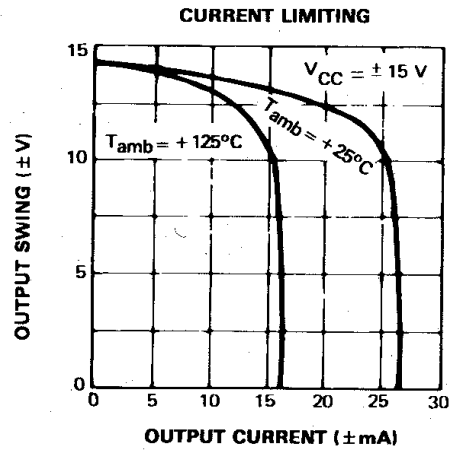
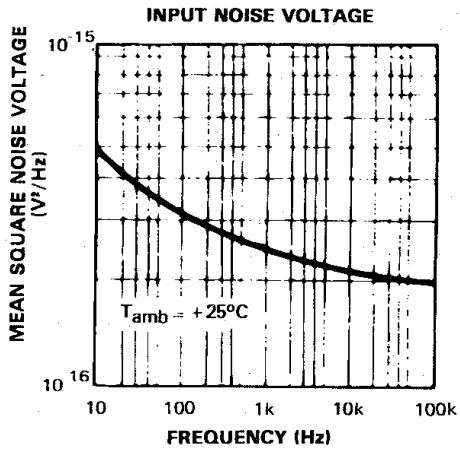
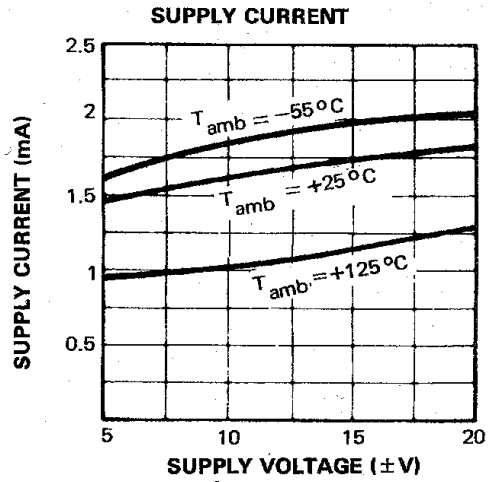
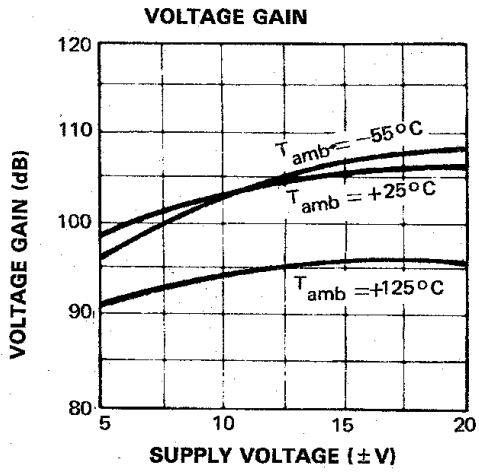

SINGLE POLE COMPENSATION

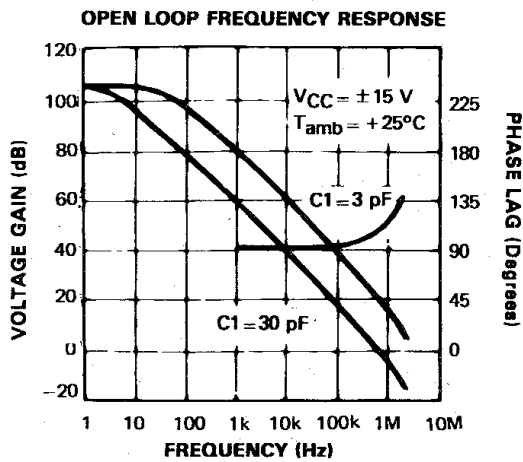

FEED FORWARD COMPENSATION

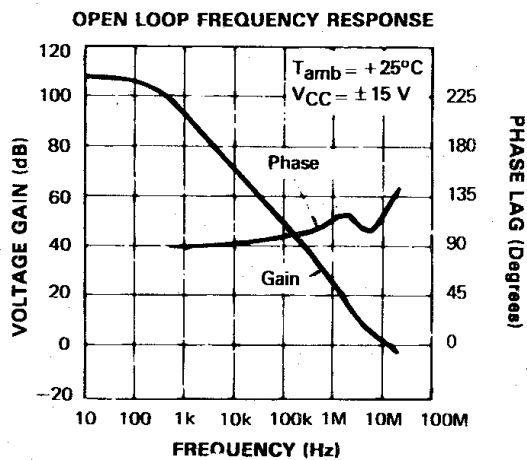

SINGLE POLE COMPENSATION

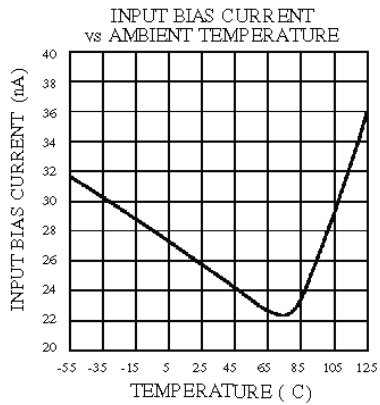
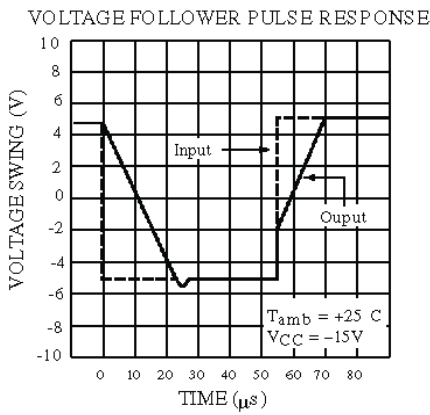
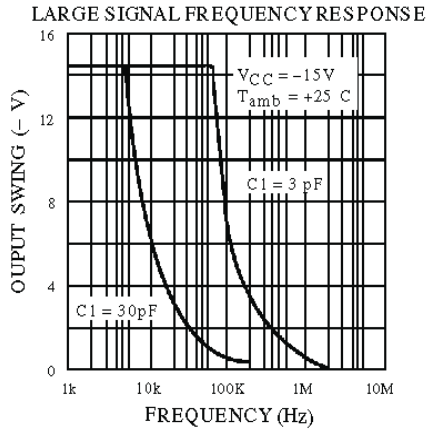

FEED FORWARD COMPENSATION

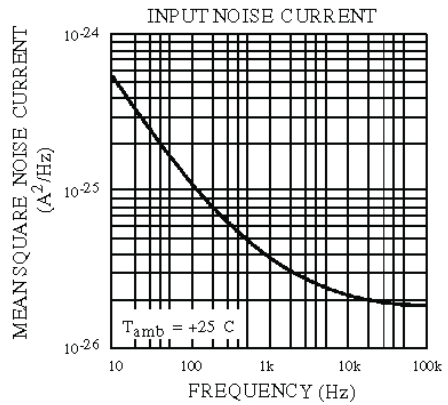
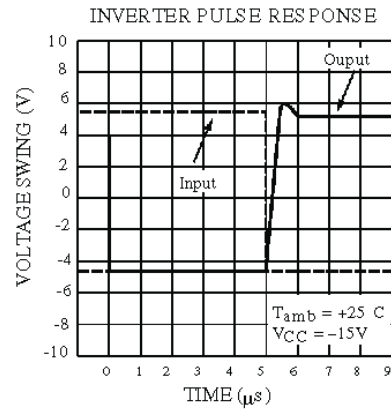
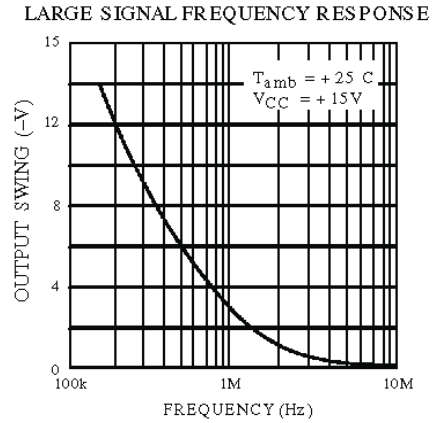

BASIC DIAGRAM

BALANCING CIRCUIT

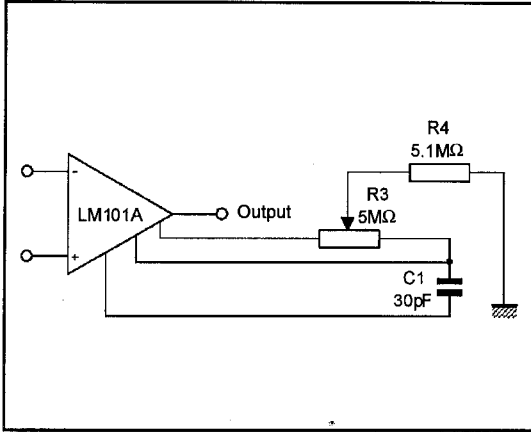

ALTERNATE BALANCING CIRCUIT

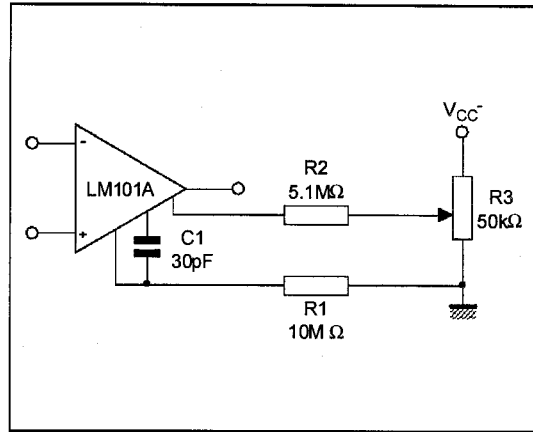

SINGLE POLE COMPENSATION

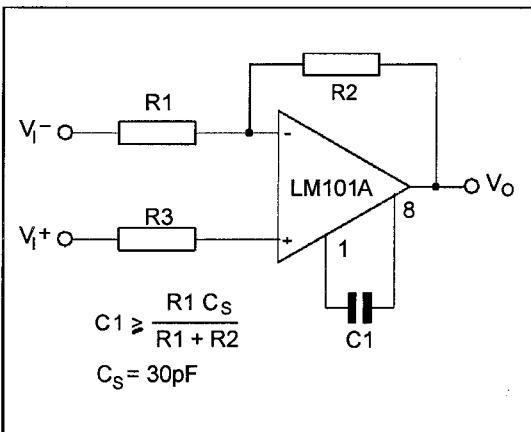

FEEDFORWARD COMPENSATION

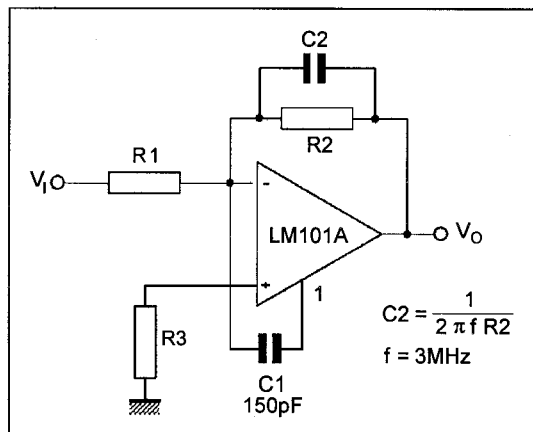

PROTECTING AGAINST GROSS FAULT CONDITIONS

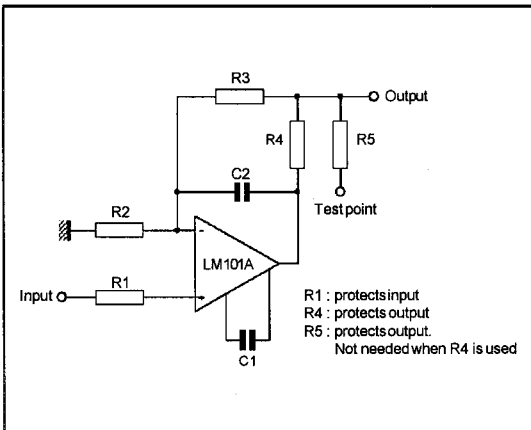

COMPENSATING FOR STRAY INPUT CAPACITANCES OR LARGE FEEDBACK RESISTOR

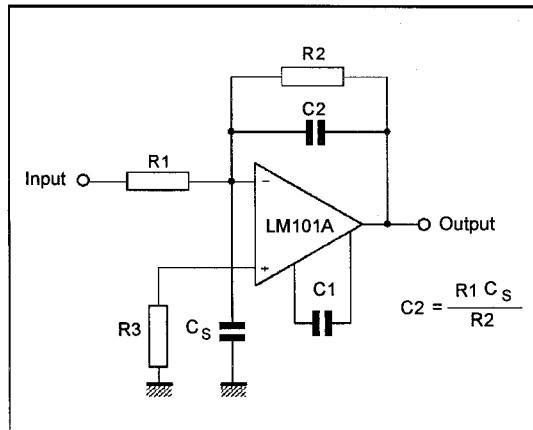

BASIC DIAGRAM (continued)

ISOLATING LARGE CAPACITIVE LOAD

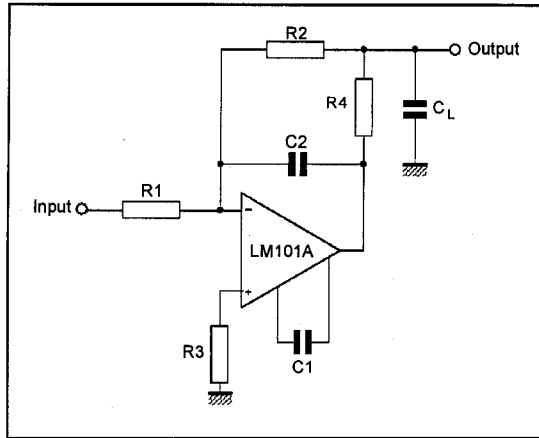

TYPICAL APPLICATIONS

SIMULATED INDUCTOR

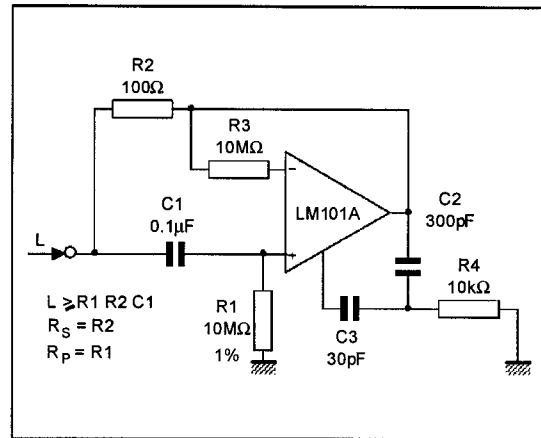

FAST AMPLIFIER WITH HIGH INPUT IMPEDANCE

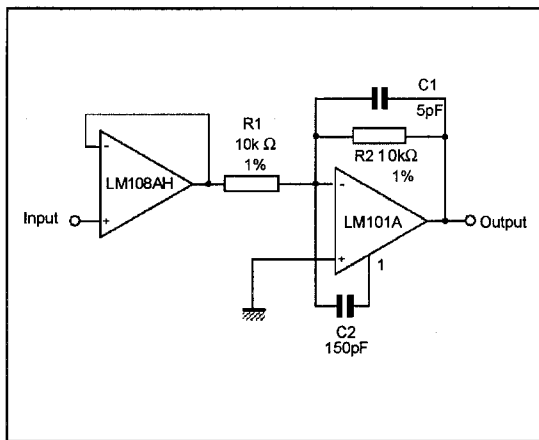

SINE WAVE OSCILLATOR

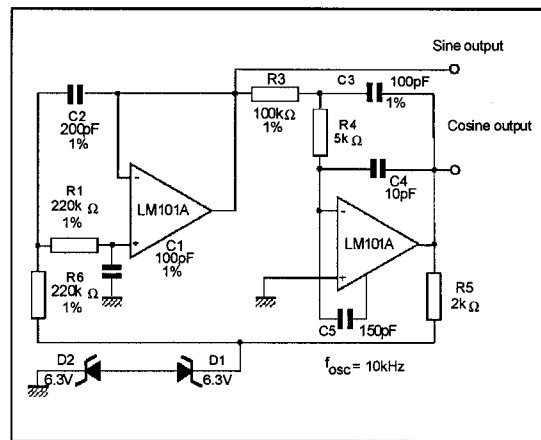

FAST AC/DC CONVERTER

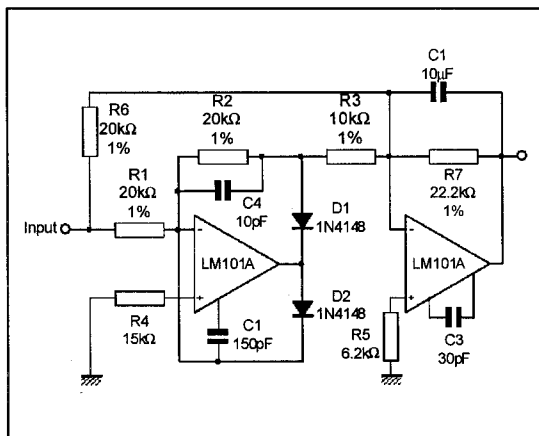

INSTRUMENTATION AMPLIFIER

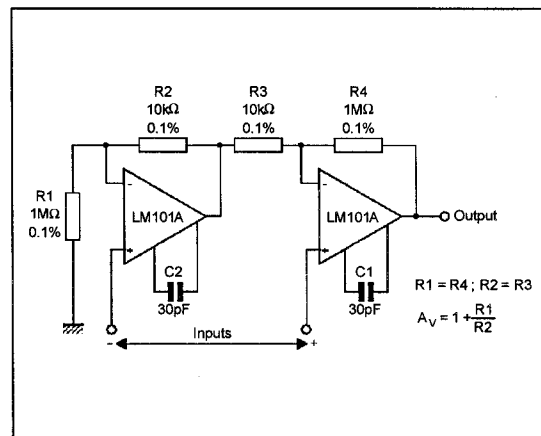

TYPICAL APPLICATIONS (continued)

VARIABLE CAPACITANCE MULTIPLIER

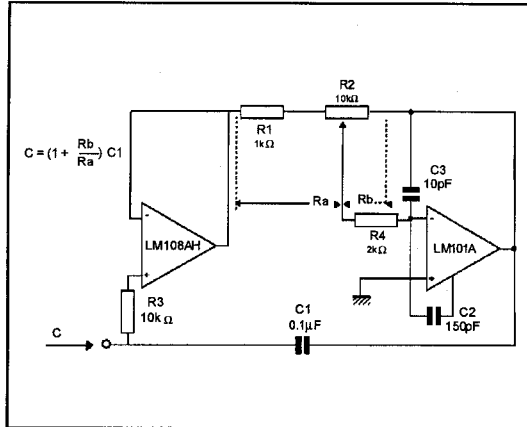

LOW FREQUENCY SQUARE WAVE GENERATOR

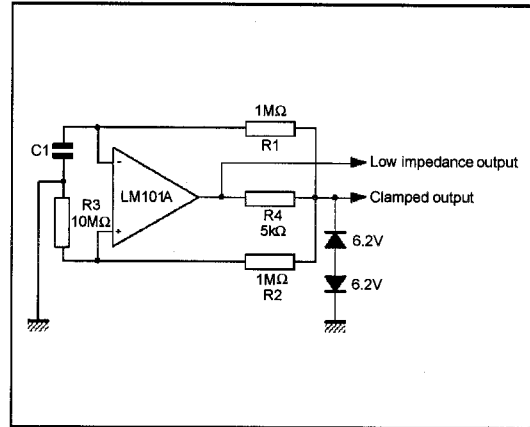

FAST HALF WAVE RECTIFIER

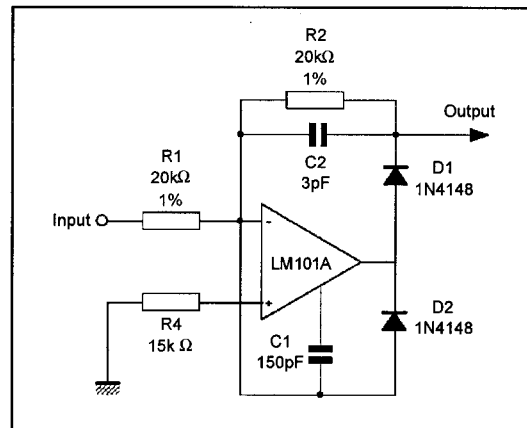

PACKAGE MECHANICAL DATA
8 PINS - PLASTIC DIP

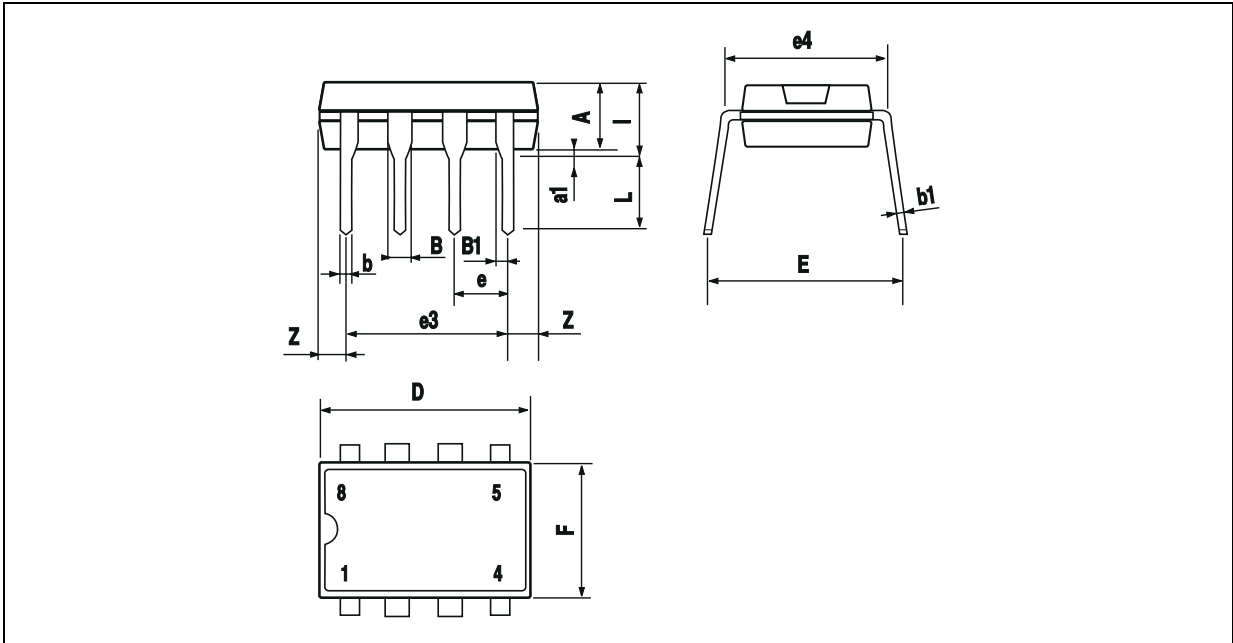

Dim.	Millimeters			Inches		
	Min.	Typ.	Max.	Min.	Typ.	Max.
A		3.32			0.131	
a1	0.51			0.020		
B	1.15		1.65	0.045		0.065
b	0.356		0.55	0.014		0.022
b1	0.204		0.304	0.008		0.012
D			10.92			0.430
E	7.95		9.75	0.313		0.384
e		2.54			0.100	
e3		7.62			0.300	
e4		7.62			0.300	
F			6.6			0.260
i			5.08			0.200
L	3.18		3.81	0.125		0.150
Z			1.52			0.060

PACKAGE MECHANICAL DATA
8 PINS - PLASTIC MICROPACKAGE (SO)

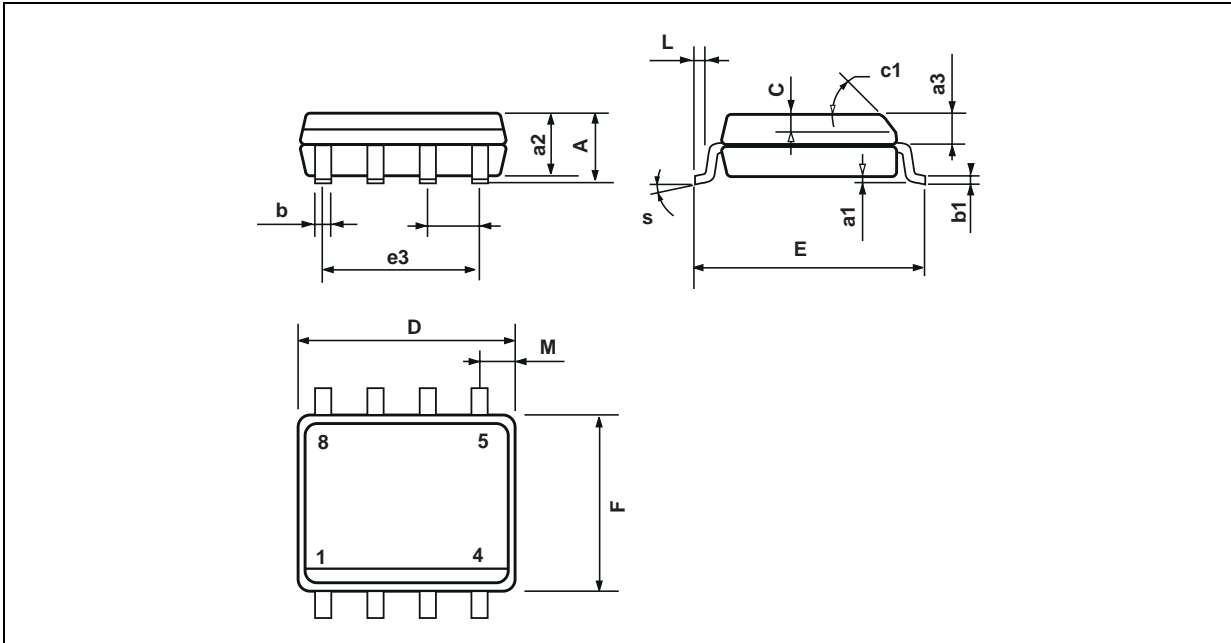

Dim.	Millimeters			Inches		
	Min.	Typ.	Max.	Min.	Typ.	Max.
A			1.75			0.069
a1	0.1		0.25	0.004		0.010
a2			1.65			0.065
a3	0.65		0.85	0.026		0.033
b	0.35		0.48	0.014		0.019
b1	0.19		0.25	0.007		0.010
C	0.25		0.5	0.010		0.020
c1	45° (typ.)					
D	4.8		5.0	0.189		0.197
E	5.8		6.2	0.228		0.244
e		1.27			0.050	
e3		3.81			0.150	
F	3.8		4.0	0.150		0.157
L	0.4		1.27	0.016		0.050
M			0.6			0.024
S	8° (max.)					

Information furnished is believed to be accurate and reliable. However, STMicroelectronics assumes no responsibility for the consequences of use of such information nor for any infringement of patents or other rights of third parties which may result from its use. No license is granted by implication or otherwise under any patent or patent rights of STMicroelectronics. Specifications mentioned in this publication are subject to change without notice. This publication supersedes and replaces all information previously supplied. STMicroelectronics products are not authorized for use as critical components in life support devices or systems without express written approval of STMicroelectronics.

© The ST logo is a registered trademark of STMicroelectronics

© 2001 STMicroelectronics - Printed in Italy - All Rights Reserved
STMicroelectronics GROUP OF COMPANIES

Australia - Brazil - Canada - China - Finland - France - Germany - Hong Kong - India - Israel - Italy - Japan - Malaysia
Malta - Morocco - Singapore - Spain - Sweden - Switzerland - United Kingdom - United States

© <http://www.st.com>



X-ON Electronics

Largest Supplier of Electrical and Electronic Components

Click to view similar products for [Operational Amplifiers - Op Amps](#) category:

Click to view products by [STMicroelectronics](#) manufacturer:

Other Similar products are found below :

[NCV33072ADR2G](#) [LM358SNG](#) [430227FB](#) [UPC824G2-A](#) [LT1678IS8](#) [042225DB](#) [058184EB](#) [UPC822G2-A](#) [UPC259G2-A](#) [UPC258G2-A](#)
[NCV33202DMR2G](#) [NTE925](#) [AZV358MTR-G1](#) [AP4310AUMTR-AG1](#) [HA1630D02MMEL-E](#) [HA1630S01LPEL-E](#) [SCY33178DR2G](#)
[NJU77806F3-TE1](#) [NCV5652MUTWG](#) [NCV20034DR2G](#) [LM324EDR2G](#) [LM2902EDR2G](#) [NTE7155](#) [NTE778S](#) [NTE871](#) [NTE924](#) [NTE937](#)
[MCP6V17T-E/MNY](#) [MCP6V19-E/ST](#) [MXD8011HF](#) [MCP6V17T-E/MS](#) [SCY6358ADR2G](#) [ADA4523-1BCPZ](#) [LTC2065HUD#PBF](#)
[ADA4523-1BCPZ-RL7](#) [NJM2904CRB1-TE1](#) [2SD965T-R](#) [RS6332PXK](#) [BDM8551](#) [BDM321](#) [MD1324](#) [COS8052SR](#) [COS8552SR](#)
[COS8554SR](#) [COS2177SR](#) [COS2353SR](#) [COS724TR](#) [ASOPD4580S-R](#) [RS321BKXF](#) [ADA4097-1HUIZ-RL7](#)