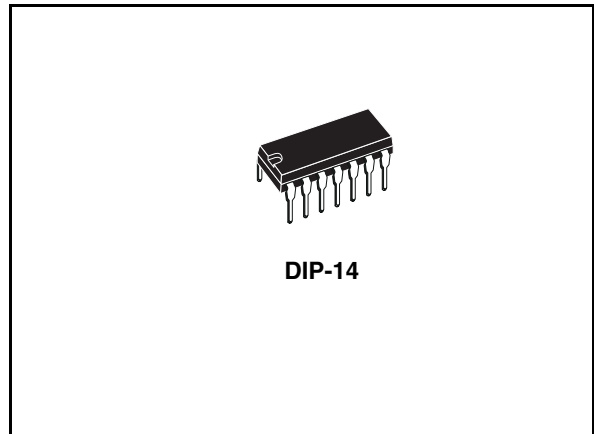

**High precision voltage regulator****Features**

- Input voltage up to 40 V
- Output voltage adjustable from 2 to 37 V
- Positive or negative supply operation
- Series, shunt, switching or floating operation
- Output current to 150 mA without external pass transistor
- Adjustable current limiting

**Description**

The LM723 is a monolithic integrated programmable voltage regulator, assembled in 14-lead dual in-line plastic package. The circuit provides internal current limiting. When the output current exceeds 150 mA an external NPN or PNP pass element may be used. Provisions are made for adjustable current limiting and remote shut-down.

**Table 1. Device summary**

Order code	Package
LM723N	DIP-14
LM723CN	DIP-14

# Contents

1	Diagram .....	3
2	Pin configuration .....	4
3	Maximum ratings .....	5
4	Circuit .....	6
5	Electrical characteristics .....	7
6	Typical performance characteristics .....	9
7	Applications information .....	12
8	Package mechanical data .....	18
9	Revision history .....	20

# 1 Diagram

Figure 1. Schematic diagram

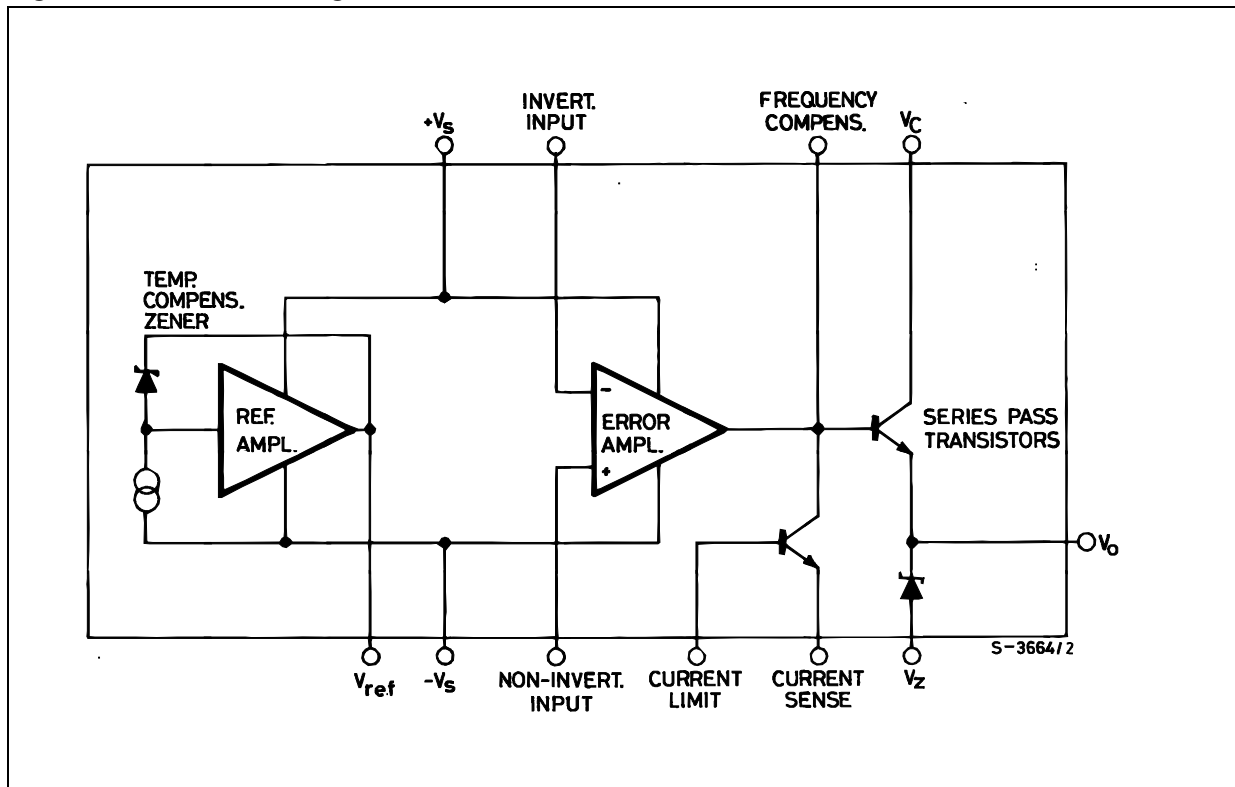

## 2 Pin configuration

Figure 2. Pin connections (top view)

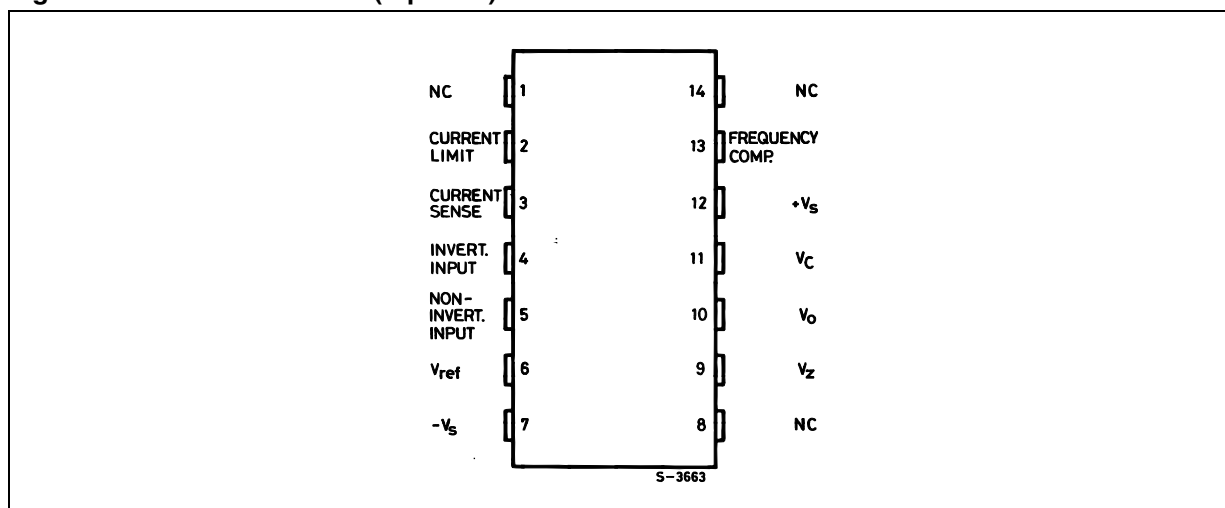

### 3 Maximum ratings

**Table 2. Absolute maximum ratings**

Symbol	Parameter	Value		Unit
		LM723	LM723C	
$V_I$	DC input voltage	40	40	V
$\Delta V_{I-O}$	Dropout voltage	40	40	V
$I_O$	Output current	150	150	mA
$I_{REF}$	Current from $V_{REF}$	15	25	mA
$T_{OP}$	Operating Temperature	-55 to 125	0 to 70	°C
$T_{STG}$	Storage Temperature	-65 to 150	-65 to 150	°C
$T_J$	Junction Temperature	150	125	°C

**Table 3. Thermal data**

Symbol	Parameter	DIP14	Unit
$R_{thJA}$	Thermal resistance junction-ambient Max	200	°C/W

## 4 Circuit

Figure 3. Test circuit (pin configuration relative to the plastic package)

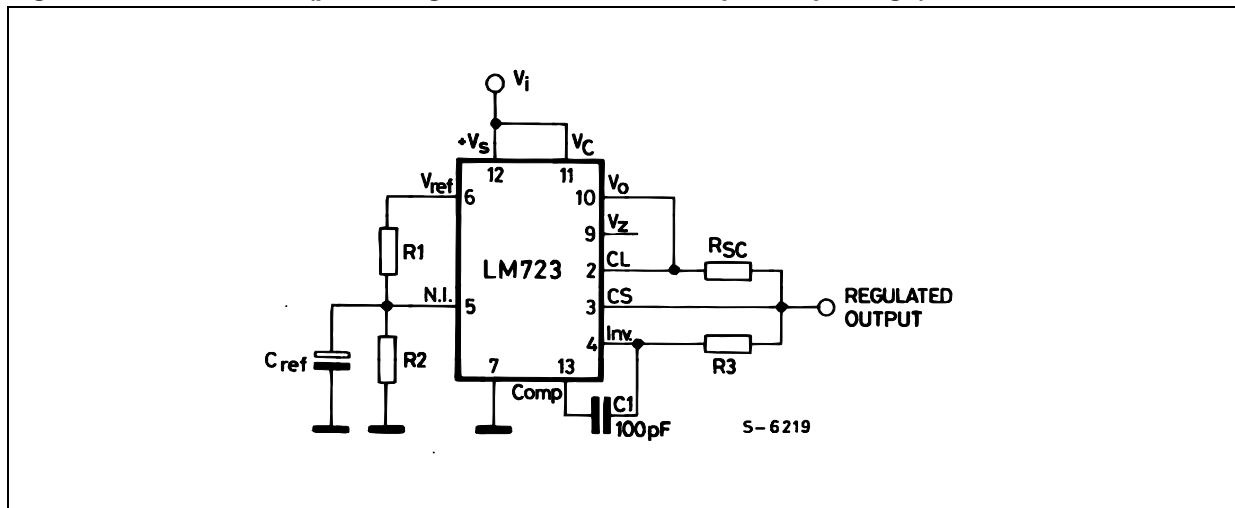

Note:  $V_I = 12\text{ V}$ ;  $V_O = 5\text{ V}$ ;  $I_O = 1\text{ mA}$ ;  $R_1/R_2 \leq 10\text{ k}\Omega$

## 5 Electrical characteristics

**Table 4. Electrical characteristics for LM723** (refer to the test circuits,  $T_A = 25\text{ }^\circ\text{C}$ , unless otherwise specified.)

Symbol	Parameter	Test conditions	Min.	Typ.	Max.	Unit
$\Delta V_O/\Delta V_I$	Line regulation	$V_I = 12\text{ to }15\text{ V}$		0.01	0.1	%
		$V_I = 12\text{ to }40\text{ V}$		0.02	0.2	
		$V_I = 12\text{ to }15\text{ V}, T_A = -55\text{ to }125^\circ\text{C}$			0.3	
$\Delta V_O/V_O$	Load regulation	$I_O = 1\text{ to }50\text{ mA}$		0.03	0.15	%
		$I_O = 1\text{ to }10\text{ mA}, T_A = -55\text{ to }125^\circ\text{C}$			0.6	
$V_{REF}$	Reference voltage	$I_{REF} = 160\text{ }\mu\text{A}$	6.95	7.15	7.35	V
SVR	Supply voltage rejection	$f = 100\text{ Hz to }10\text{ kHz}$	$C_{REF} = 0$		74	dB
			$C_{REF} = 5\text{ }\mu\text{F}$		86	
$\Delta V_O/\Delta T$	Output voltage drift				150	ppm/ $^\circ\text{C}$
$I_{SC}$	Output current limit	$R_{SC} = 10\text{ }\Omega, V_O = 0\text{ V}$		65		mA
$V_I$	Input voltage range		9.5		40	V
$V_O$	Output voltage range		2		37	V
$V_O - V_I$			3		38	V
$I_d$	Quiescent current	$V_I = 30\text{ V}, I_O = 0\text{ mA}$		2.3	5	mA
$K_{VH}$	Long term stability			0.1		%/1000 hrs
eN	Output noise voltage	BW = 100 Hz to 10 kHz	$C_{REF} = 0$		20	$\mu\text{V}$
			$C_{REF} = 5\text{ }\mu\text{F}$		2.5	

**Table 5. Electrical characteristics for LM723C** (refer to the test circuits,  $T_A = 25\text{ }^\circ\text{C}$ , unless otherwise specified.)

Symbol	Parameter	Test conditions	Min.	Typ.	Max.	Unit
$\Delta V_O/\Delta V_I$	Line regulation	$V_I = 12\text{ to }15\text{ V}$		0.01	0.1	%
		$V_I = 12\text{ to }40\text{ V}$		0.1	0.5	
		$V_I = 12\text{ to }15\text{ V}, T_A = 0\text{ to }70\text{ }^\circ\text{C}$			0.3	
$\Delta V_O/V_O$	Load regulation	$I_O = 1\text{ to }50\text{ mA}$		0.03	0.2	%
		$I_O = 1\text{ to }10\text{ mA}, T_A = 0\text{ to }70\text{ }^\circ\text{C}$			0.6	
$V_{REF}$	Reference voltage	$I_{REF} = 160\text{ }\mu\text{A}$	6.8	7.15	7.5	V
SVR	Supply voltage rejection	$f = 100\text{ Hz to }10\text{ kHz}$	$C_{REF} = 0$		74	dB
			$C_{REF} = 5\text{ }\mu\text{F}$		86	
$\Delta V_O/\Delta T$	Output voltage drift				150	ppm/ $^\circ\text{C}$
$I_{SC}$	Output current limit	$R_{SC} = 10\text{ }\Omega, V_O = 0\text{ V}$		65		mA
$V_I$	Input voltage range		9.5		40	V
$V_O$	Output voltage range		2		37	V
$V_O - V_I$			3		38	V
$I_d$	Quiescent current	$V_I = 30\text{ V}, I_O = 0\text{ mA}$		2.3	4	mA
$K_{VH}$	Long term stability			0.1		%/1000 hrs
eN	Output noise voltage	BW = 100 Hz to 10 kHz	$C_{REF} = 0$		20	$\mu\text{V}$
			$C_{REF} = 5\text{ }\mu\text{F}$		2.5	



## 6 Typical performance characteristics

(unless otherwise specified  $V_{O(NOM)} = 3.3\text{ V}$ )

Figure 4. Maximum output current vs voltage drop      Figure 5. Current limiting characteristics

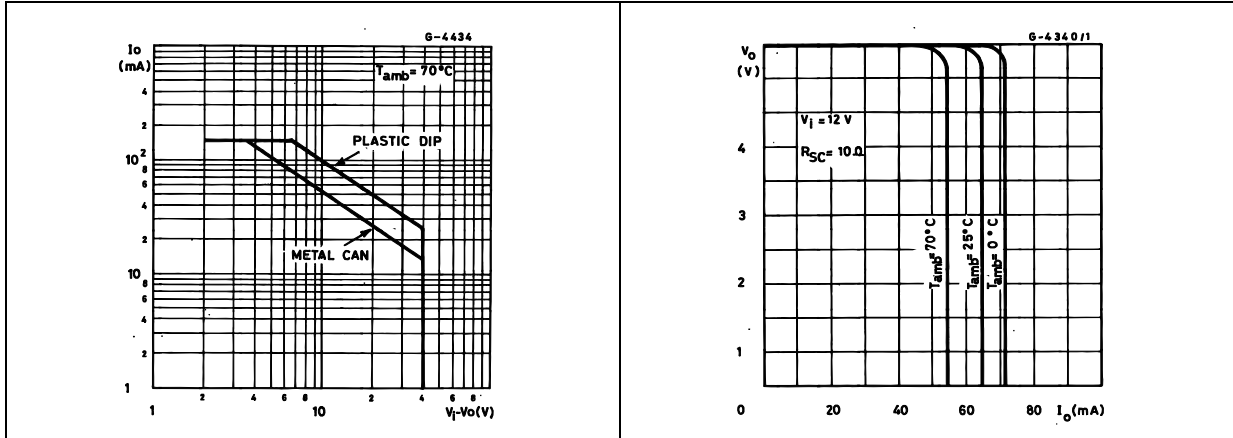

Figure 6. Current limiting characteristics vs junction temperature      Figure 7. Load regulation characteristics without current limiting

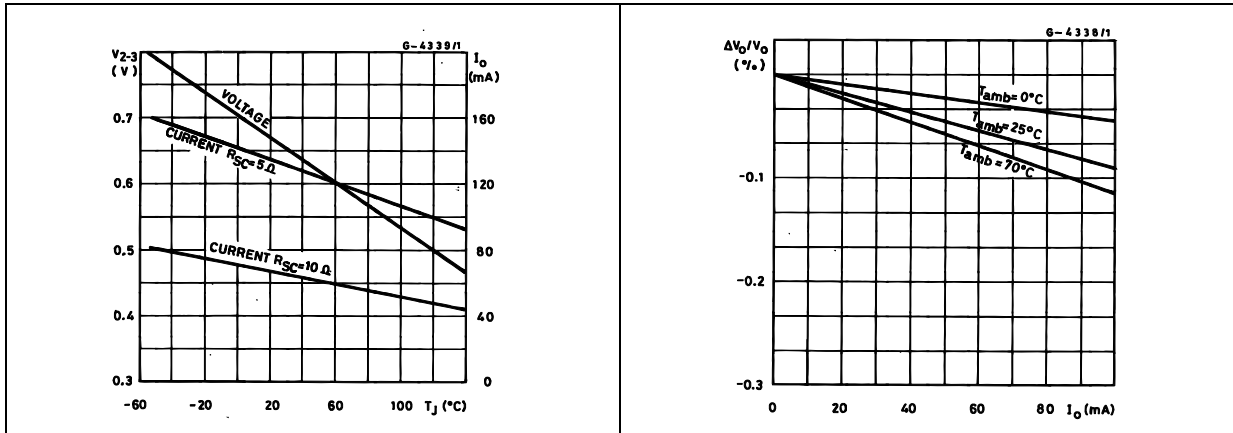

Figure 8. Load regulation characteristics with current limiting      Figure 9. Load regulation characteristics with current limiting

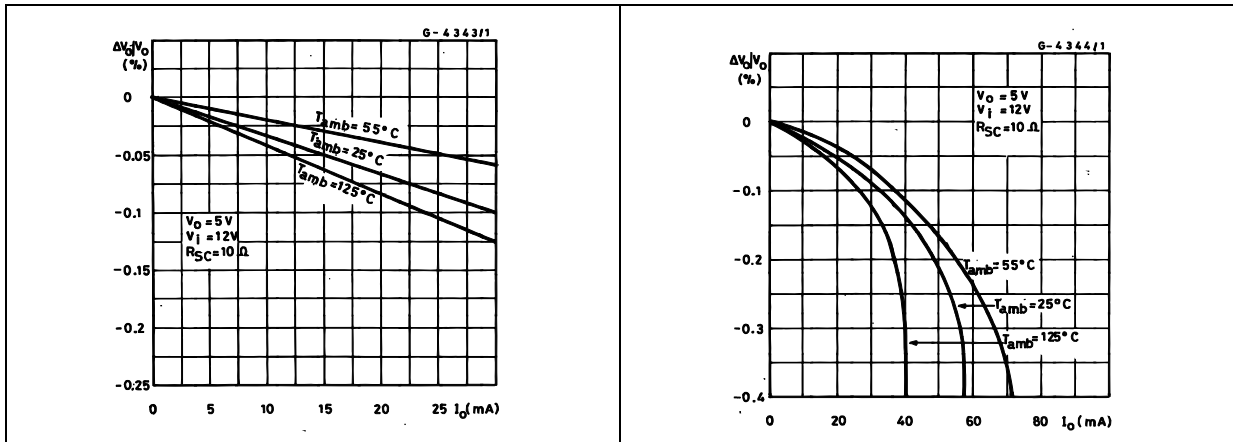

Figure 10. Line regulation vs voltage drop

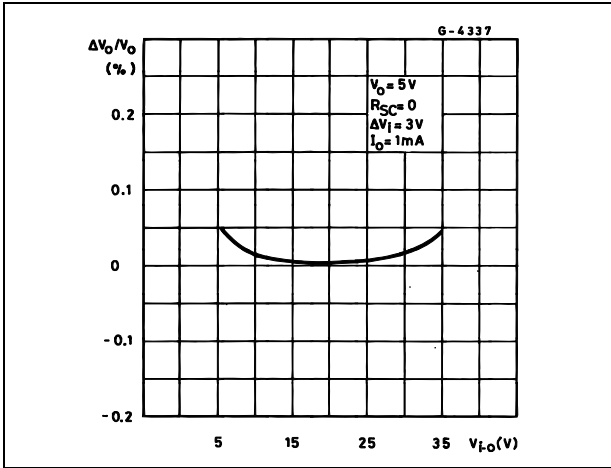

Figure 11. Load regulation vs voltage drop

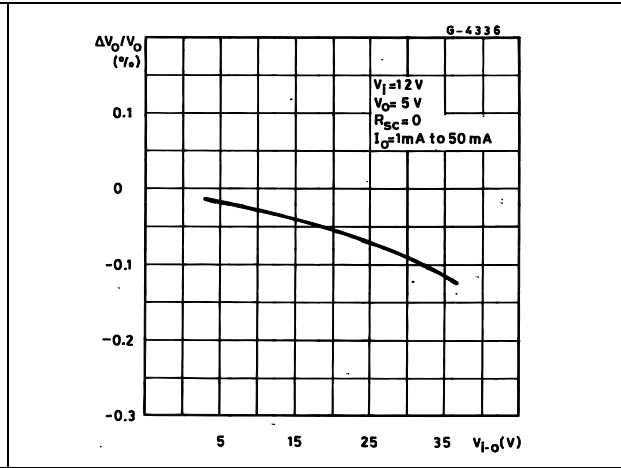

Figure 12. Quiescent drain current vs input voltage

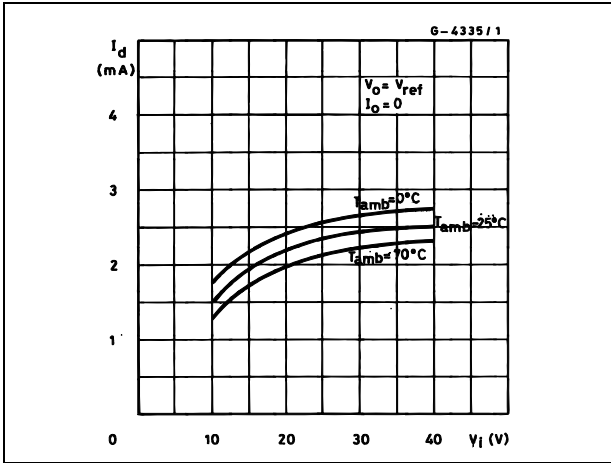

Figure 13. Line transient response

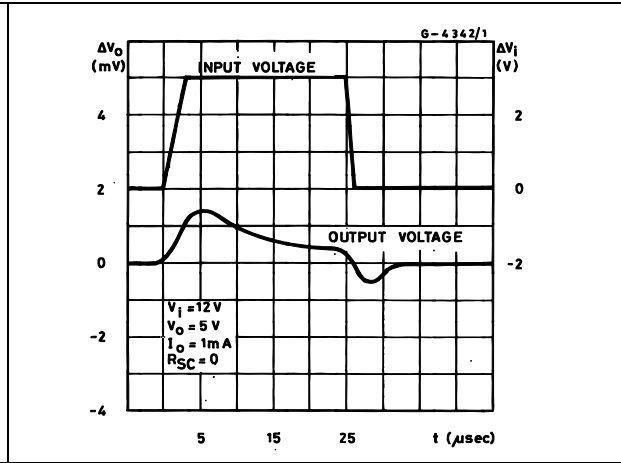

Figure 14. Load transient response

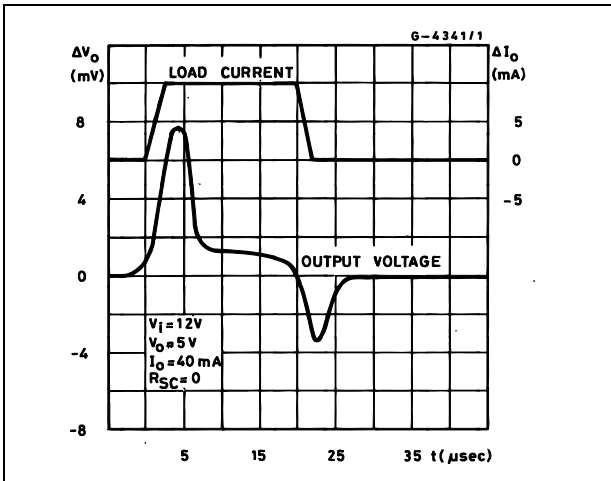

Figure 15. Output impedance vs frequency

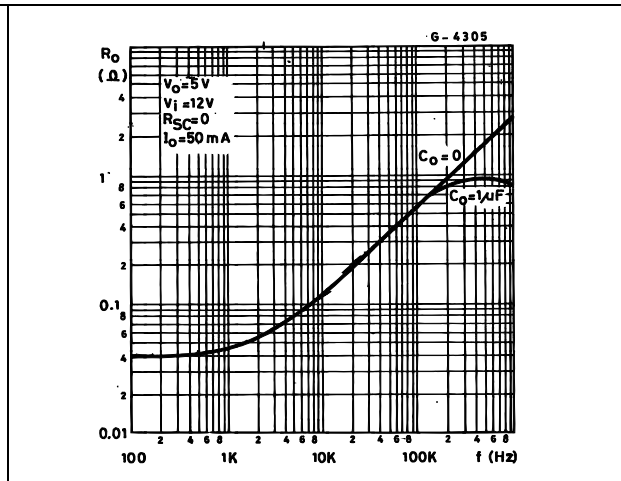

Table 6. Resistor values (kΩ) for standard output voltages

Output Voltage	Applicable figures	Fixed output ± 5%		Output adjustable ± 10% <sup>(1)</sup>		
		R1	R2	R1	P1	R2
+3	16, 18, 20, 21, 24, 26	4.12	3.01	1.8	0.5	1.2
+5	16, 18, 20, 21, 24, 26	2.15	4.99	0.75	0.5	2.2
+6	16, 18, 20, 21, 24, 26	1.15	6.04	0.5	0.5	2.7
+9	17, 18, 20, 21, 24, 26	1.87	7.15	0.75	1	2.7
+12	17, 18, 20, 21, 24, 26	4.87	7.15	2	1	3
+15	17, 18, 20, 21, 24, 26	7.87	7.15	3.3	1	3
+28	17, 18, 20, 21, 24, 26	21	7.15	5.6	1	2
+45	22	3.57	48.7	2.2	10	39
+75	22	3.57	78.7	2.2	10	68
+100	22	3.57	102	2.2	10	91
+250	22	3.57	255	2.2	10	240
-6 <sup>(2)</sup>	18	3.57	2.43	1.2	0.5	0.75
-9	18	3.48	5.36	1.2	0.5	2
-12	18	3.57	8.45	1.2	0.5	3.3
-15	18	3.65	11.5	1.2	0.5	4.3
-28	18	3.57	24.3	1.2	0.5	10
-45	23	3.57	21.2	2.2	10	33
-100	23	3.57	97.6	2.2	10	91
-250	23	3.57	249	2.2	10	240

1. Replace R1/R2 divider with the circuit of [Figure 27](#).

2. V+ must be connected to a +3 V or greater supply.

Table 7. Formula for intermediate output voltages

Conditions		
Outputs from 2 to 7V <a href="#">Figure 16, 19, 20, 21, 24, 26</a> $V_O = (V_{REF} \times R_2) / (R_1 + R_2)$	Outputs from 4 to 250V <a href="#">Figure 22</a> $V_O = (V_{REF}/2) \times [(R_2 - R_1) / R_1] ; R_3 = R_4$	Current Limit $I_{LIMIT} = V_{SENSE} / R_{SC}$
Outputs from 7 to 37V <a href="#">Figure 17, 19, 20, 21, 24, 26</a> $V_O = V_{REF} \times [(R_1 + R_2) / R_2]$	Outputs from -6 to -250V <a href="#">Figure 18, Figure 23</a> $V_O = (V_{REF}/2) \times [(R_1 + R_2) / R_1] ; R_3 = R_4$	Foldback Current Limiting $I_{KNEE} = [(V_O \times R_3) / (R_{SC} \times R_4)] \times [V_{SENSE} \times (R_3 + R_4) / (R_{SC} \times R_4)]$ $I_{SHORTCKT} = (V_{SENSE} / R_{SC}) \times [(R_3 + R_4) / R_4]$

## 7 Applications information

Figure 16. Basic low voltage regulator ( $V_O = 2$  to  $7$  V)

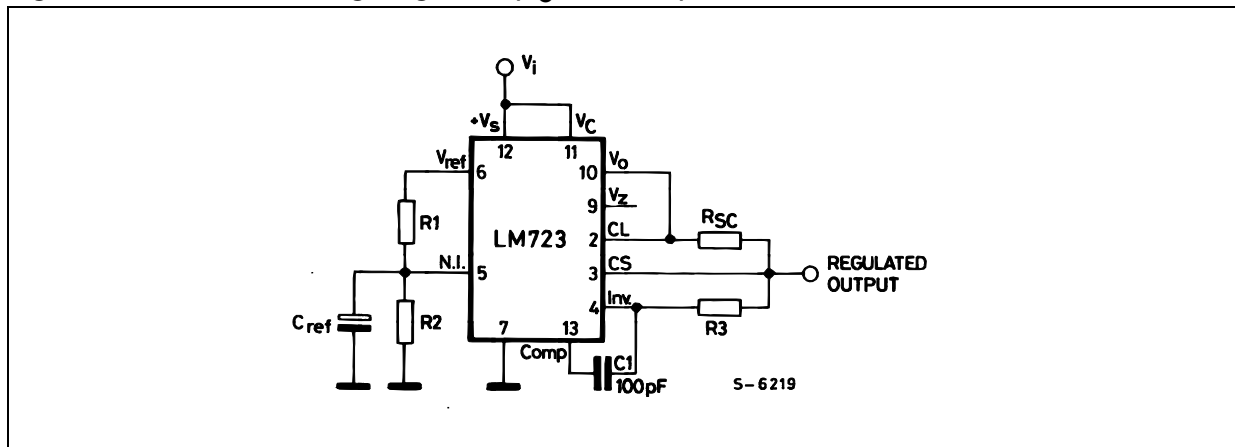

Note:  $R_3 = (R_1 \times R_2) / (R_1 + R_2)$  for minimum temperature drift.  
 $R_3$  may be eliminated for minimum component count.  
 Typical performance  
 Regulated output voltage.....5 V  
 Line regulation ( $\Delta V_I = 3$  V).....0.5 mV  
 Load regulation ( $\Delta I_O = 50$  mA)...1.5 mV

Figure 17. Basic high voltage regulator ( $V_O = 7$  to  $37$  V)

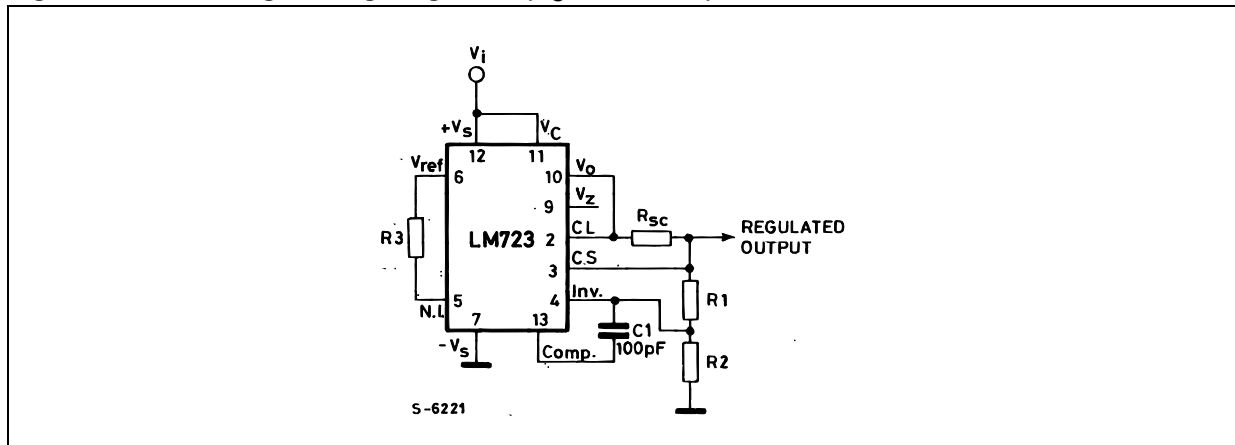

Note:  $R_3 = (R_1 \times R_2) / (R_1 + R_2)$  for minimum temperature drift.  
 $R_3$  may be eliminated for minimum component count.  
 Typical performance  
 Regulated output voltage.....15 V  
 Line regulation ( $\Delta V_I = 3$  V).....1.5 mV  
 Load regulation ( $\Delta I_O = 50$  mA)....4.5 mV

Figure 18. Negative voltage regulator

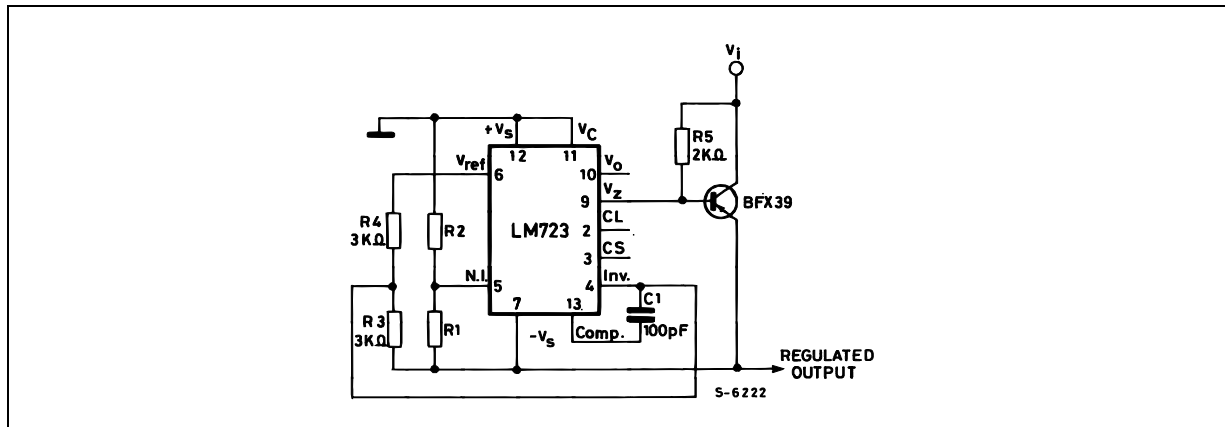

Note: Typical performance  
 Regulated output voltage.....15 V  
 Line regulation ( $\Delta V_I = 3 V$ ).....1 mV  
 Load regulation ( $\Delta I_O = 100 mA$ ).....2 mV

Figure 19. Positive voltage regulator (external NPN pass transistor)

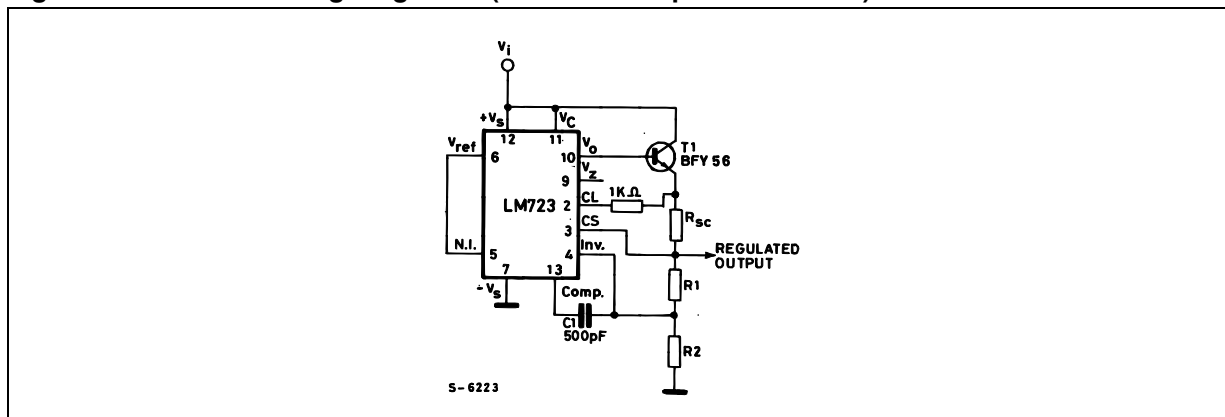

Note: Typical performance  
 Regulated output voltage.....15 V  
 Line regulation ( $\Delta V_I = 3 V$ ).....1.5 mV  
 Load regulation ( $\Delta I_O = 1 A$ ).....15 mV

**Figure 20. Positive voltage regulator (external PNP pass transistor)**

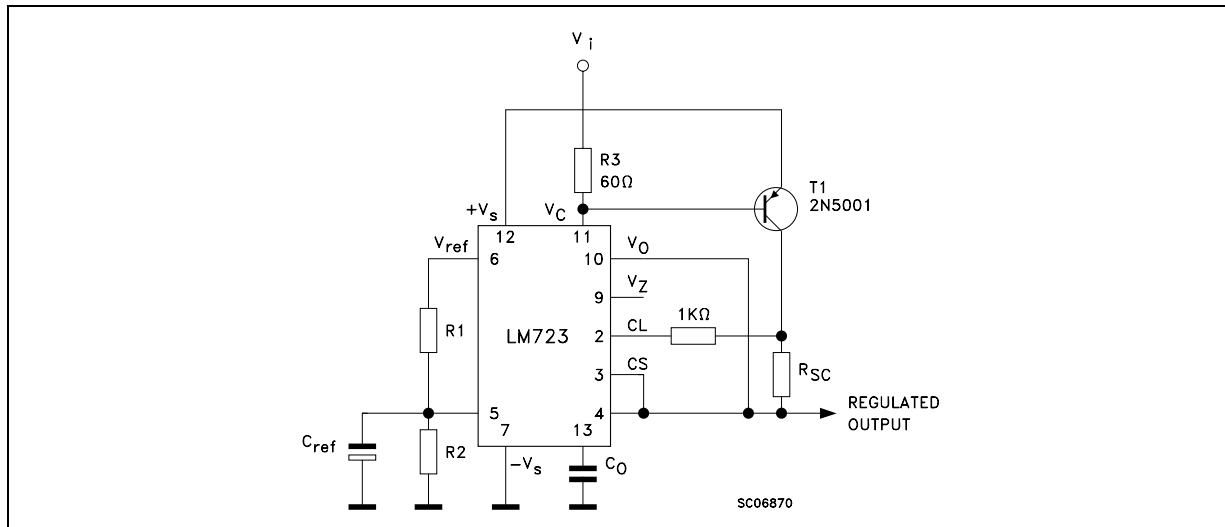

*Note:* Typical performance  
 Regulated output voltage.....5 V  
 Line regulation ( $\Delta V_I = 3 V$ ).....0.5 mV  
 Load regulation ( $\Delta I_O = 1 A$ ).....1.5 mV

**Figure 21. Foldback current limiting**

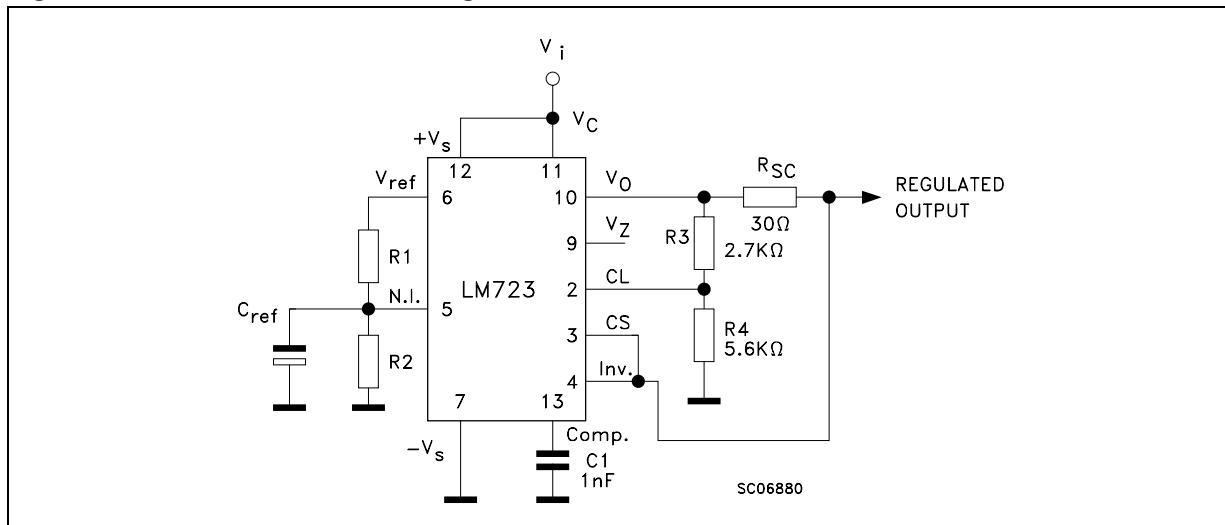

*Note:* Typical performance  
 Regulated output voltage.....5 V  
 Line regulation ( $\Delta V_I = 3 V$ ).....0.5 mV  
 Load regulation ( $\Delta I_O = 10 mA$ ).....1 mV  
 Current limit knee.....20 mA

Figure 22. Positive floating regulator

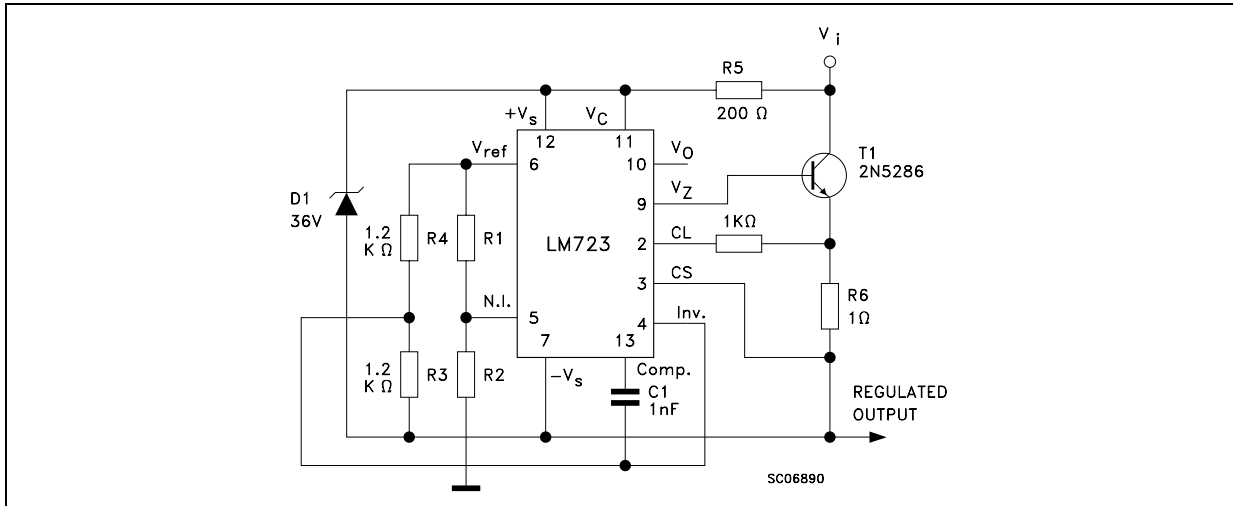

Note: Typical performance  
 Regulated output voltage.....100 V  
 Line regulation ( $\Delta V_I = 20 V$ ).....15 mV  
 Load regulation ( $\Delta I_O = 50 mA$ ).....20 mV

Figure 23. Negative floating regulator

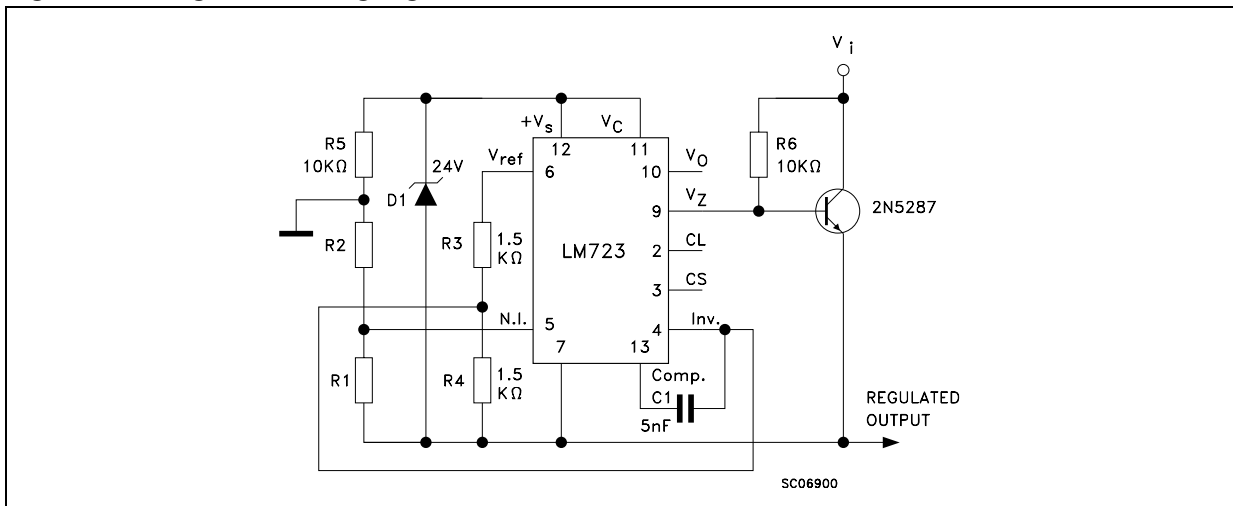

Note: Typical performance  
 Regulated output voltage.....-100 V  
 Line regulation ( $\Delta V_I = 20 V$ ).....30 mV  
 Load regulation ( $\Delta I_O = 100 mA$ ).....20 mV

Figure 24. Positive switching regulator

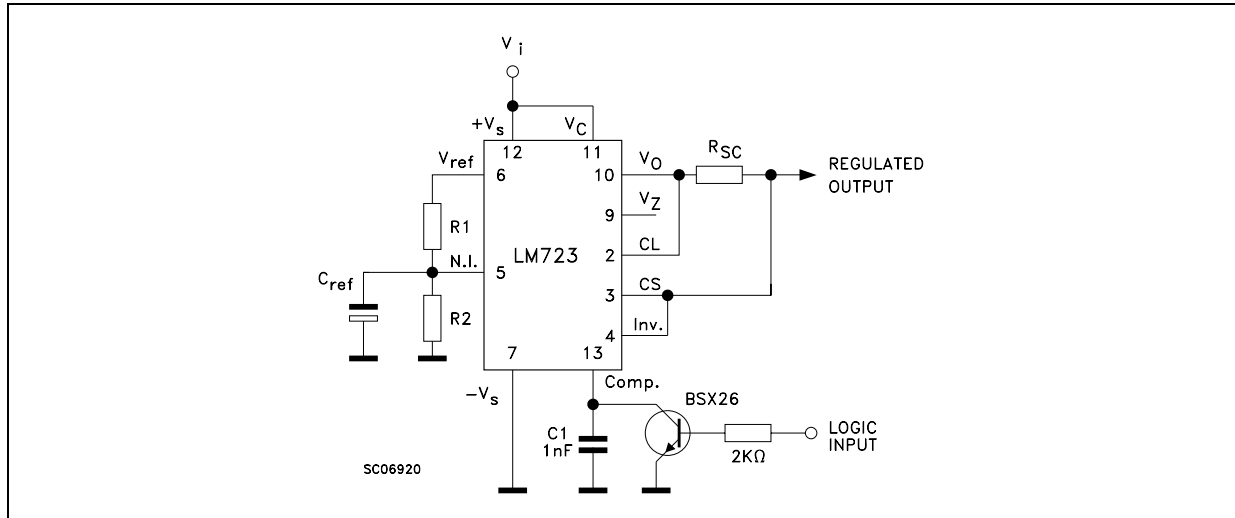

Note: *Typical performance*  
 Regulated output voltage.....5 V  
 Line regulation ( $\Delta V_I = 30 V$ ).....10 mV  
 Load regulation ( $\Delta I_O = 2 A$ ).....80 mV

Figure 25. Remote shutdown regulator with current limiting

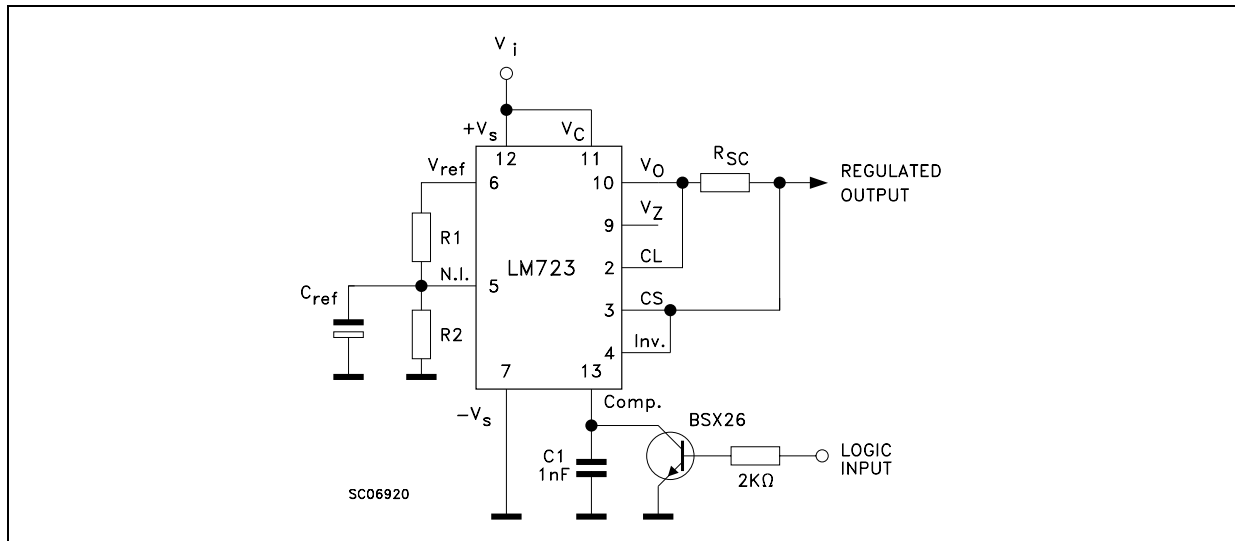

Note: *Current limit transistor may be used for shutdown if current limiting is not required.*  
*Typical performance*  
 Regulated output voltage.....5 V  
 Line regulation ( $\Delta V_I = 3 V$ ).....0.5 mV  
 Load regulation ( $\Delta I_O = 50 mA$ ).....1.5 mV



Figure 26. Shunt regulator

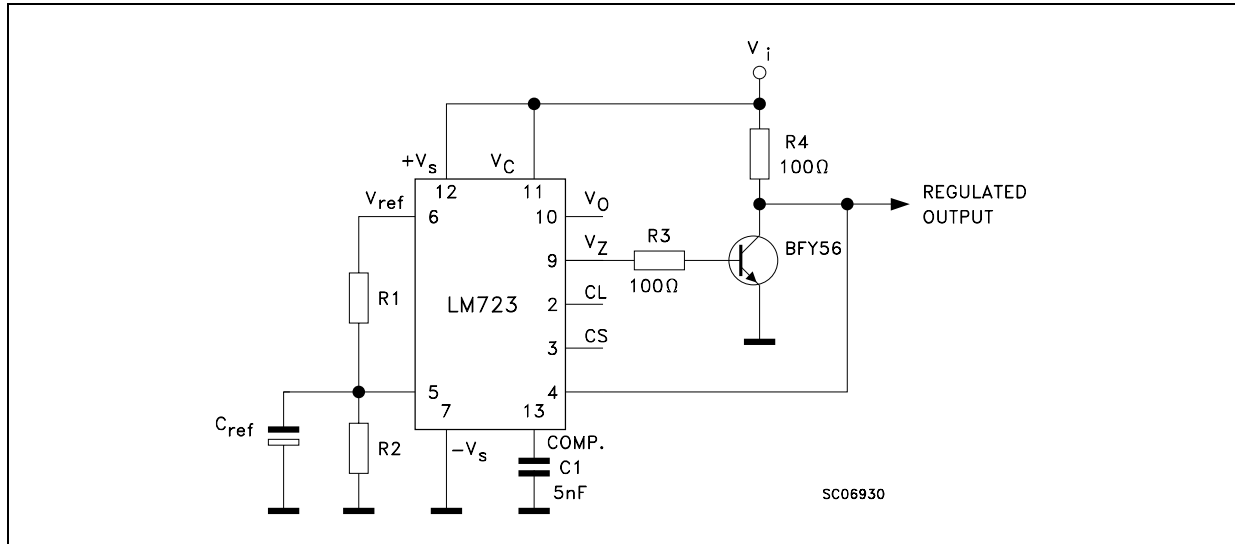

Note: *Typical performance*

Regulated output voltage.....	5 V
Line regulation ( $\Delta V_I = 10 V$ ).....	2 mV
Load regulation ( $\Delta I_O = 100 mA$ ).....	5 mV

Figure 27. Output voltage adjust

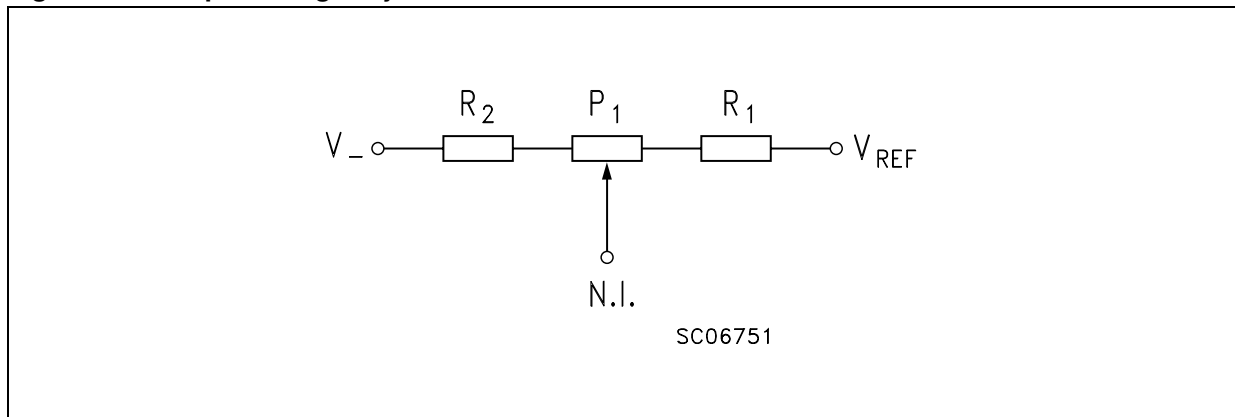

## 8 Package mechanical data

In order to meet environmental requirements, ST offers these devices in ECOPACK<sup>®</sup> packages. These packages have a lead-free second level interconnect. The category of second Level Interconnect is marked on the package and on the inner box label, in compliance with JEDEC Standard JESD97. The maximum ratings related to soldering conditions are also marked on the inner box label. ECOPACK is an ST trademark. ECOPACK specifications are available at: [www.st.com](http://www.st.com).

**Plastic DIP-14 mechanical data**

Dim.	mm.			inch.		
	Min.	Typ.	Max.	Min.	Typ.	Max.
a1	0.51			0.020		
B	1.39		1.65	0.055		0.065
b		0.5			0.020	
b1		0.25			0.010	
D			20			0.787
E		8.5			0.335	
e		2.54			0.100	
e3		15.24			0.600	
F			7.1			0.280
I			5.1			0.201
L		3.3			0.130	
Z	1.27		2.54	0.050		0.100

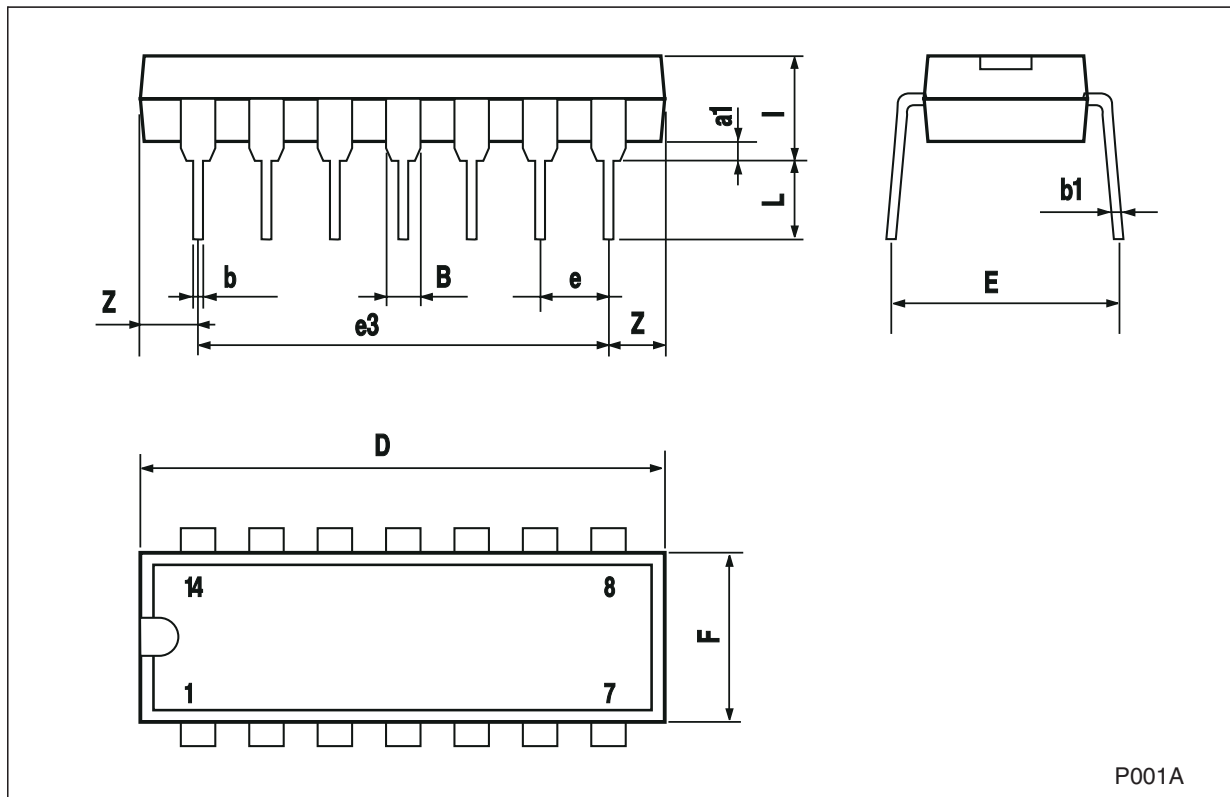

## 9 Revision history

**Table 8. Document revision history**

Date	Revision	Changes
21-Jun-2004	5	
22-Nov-2007	6	Added <a href="#">Table 1</a> .

**Please Read Carefully:**

Information in this document is provided solely in connection with ST products. STMicroelectronics NV and its subsidiaries ("ST") reserve the right to make changes, corrections, modifications or improvements, to this document, and the products and services described herein at any time, without notice.

All ST products are sold pursuant to ST's terms and conditions of sale.

Purchasers are solely responsible for the choice, selection and use of the ST products and services described herein, and ST assumes no liability whatsoever relating to the choice, selection or use of the ST products and services described herein.

No license, express or implied, by estoppel or otherwise, to any intellectual property rights is granted under this document. If any part of this document refers to any third party products or services it shall not be deemed a license grant by ST for the use of such third party products or services, or any intellectual property contained therein or considered as a warranty covering the use in any manner whatsoever of such third party products or services or any intellectual property contained therein.

**UNLESS OTHERWISE SET FORTH IN ST'S TERMS AND CONDITIONS OF SALE ST DISCLAIMS ANY EXPRESS OR IMPLIED WARRANTY WITH RESPECT TO THE USE AND/OR SALE OF ST PRODUCTS INCLUDING WITHOUT LIMITATION IMPLIED WARRANTIES OF MERCHANTABILITY, FITNESS FOR A PARTICULAR PURPOSE (AND THEIR EQUIVALENTS UNDER THE LAWS OF ANY JURISDICTION), OR INFRINGEMENT OF ANY PATENT, COPYRIGHT OR OTHER INTELLECTUAL PROPERTY RIGHT.**

**UNLESS EXPRESSLY APPROVED IN WRITING BY AN AUTHORIZED ST REPRESENTATIVE, ST PRODUCTS ARE NOT RECOMMENDED, AUTHORIZED OR WARRANTED FOR USE IN MILITARY, AIR CRAFT, SPACE, LIFE SAVING, OR LIFE SUSTAINING APPLICATIONS, NOR IN PRODUCTS OR SYSTEMS WHERE FAILURE OR MALFUNCTION MAY RESULT IN PERSONAL INJURY, DEATH, OR SEVERE PROPERTY OR ENVIRONMENTAL DAMAGE. ST PRODUCTS WHICH ARE NOT SPECIFIED AS "AUTOMOTIVE GRADE" MAY ONLY BE USED IN AUTOMOTIVE APPLICATIONS AT USER'S OWN RISK.**

Resale of ST products with provisions different from the statements and/or technical features set forth in this document shall immediately void any warranty granted by ST for the ST product or service described herein and shall not create or extend in any manner whatsoever, any liability of ST.

ST and the ST logo are trademarks or registered trademarks of ST in various countries.

Information in this document supersedes and replaces all information previously supplied.

The ST logo is a registered trademark of STMicroelectronics. All other names are the property of their respective owners.

© 2007 STMicroelectronics - All rights reserved

STMicroelectronics group of companies

Australia - Belgium - Brazil - Canada - China - Czech Republic - Finland - France - Germany - Hong Kong - India - Israel - Italy - Japan - Malaysia - Malta - Morocco - Singapore - Spain - Sweden - Switzerland - United Kingdom - United States of America

[www.st.com](http://www.st.com)

## X-ON Electronics

Largest Supplier of Electrical and Electronic Components

*Click to view similar products for [Linear Voltage Regulators](#) category:*

*Click to view products by [STMicroelectronics](#) manufacturer:*

Other Similar products are found below :

[LV56831P-E](#) [LV5684PVD-XH](#) [MCDTSA6-2R](#) [L7815ACV-DG](#) [LV56801P-E](#) [TCR3DF13,LM\(CT](#) [TCR3DF39,LM\(CT](#) [TLE42794G](#)  
[L78L05CZ/1SX](#) [L78LR05DL-MA-E](#) [LM317T](#) [636416C](#) [714954EB](#) [LV5680P-E](#) [L78M15CV-DG](#) [L79M05T-E](#) [TLS202A1MBVHTSA1](#)  
[L78LR05D-MA-E](#) [NCV317MBTG](#) [NTE7227](#) [LV5680NPVC-XH](#) [LT1054CN8](#) [ME6208A50M3G](#) [SL7533-8](#) [ME6231A50M3G](#)  
[ME6231A50PG](#) [ME6231C50M5G](#) [AMS1117S-3.3](#) [AMS1117-5.0](#) [AMS1117S-5.0](#) [AMS1117-3.3](#) [MD5118](#) [MD5121](#) [MD5127](#) [MD5128](#)  
[MD5130](#) [MD5144](#) [MD5150](#) [MD5115](#) [MD5125](#) [MD5133](#) [MD5136](#) [MD5140](#) [MD5110](#) [MD52E18WB6](#) [MD52E33WB6](#) [MD52E15QA3](#)  
[MD52E21QA3](#) [MD52E25QA3](#) [MD52E28QA3](#)