

Low noise dual operational amplifier

Features

- Low voltage noise: 4.5 nV/√Hz
- High gain bandwidth product: 15 MHz
- High slew rate: 7 V/μs
- Low distortion: 0.002%
- Excellent frequency stability
- ESD protection 2 kV

Applications

- Audio systems
- Preamplification, filtering

Description

The LM833 is a monolithic dual operational amplifier particularly well-suited to audio applications.

It offers low voltage noise (4.5 nV/√Hz) and high frequency performances (15 MHz gain bandwidth product, 7 V/μs slew rate).

In addition, the LM833 has a very low distortion (0.002%) and excellent phase/gain margins.

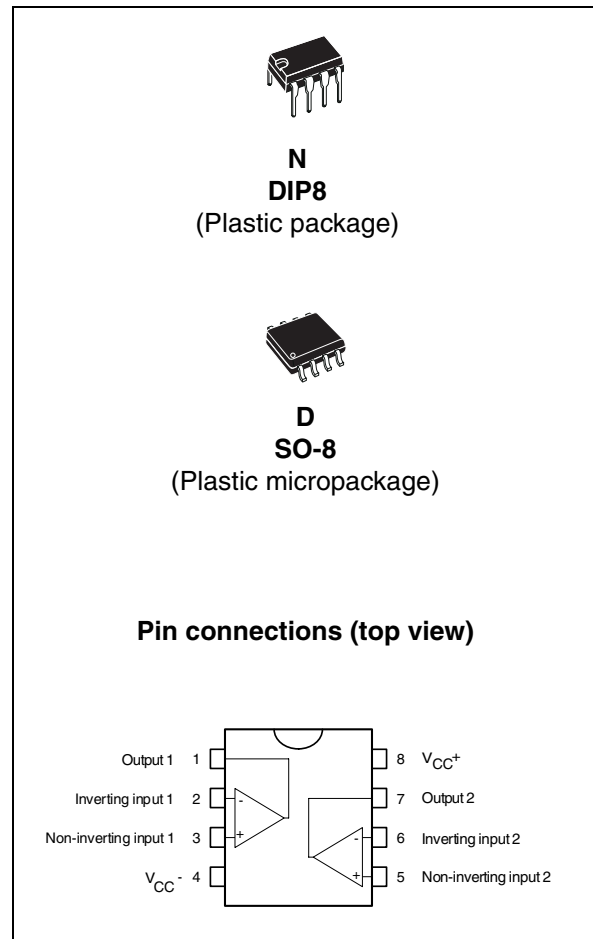

1 Absolute maximum ratings

Table 1. Key parameters and their absolute maximum ratings

Symbol	Parameter	Value	Unit
V_{CC}	Supply voltage	± 18 or $+36$	V
V_{id}	Differential input voltage ⁽¹⁾	± 30	V
V_i	Input voltage ⁽¹⁾	± 15	V
I_{in}	Input current ⁽²⁾ : V_{in} driven negative	5 mA in DC or 50 mA in AC (duty cycle = 10%, T=1s)	mA
	Input current ⁽³⁾ : V_{in} driven positive above AMR value	0.4	
	Output short-circuit duration	Infinite	s
T_j	Junction temperature	+150	°C
T_{stg}	Storage temperature	-65 to +150	°C
P_{tot}	Maximum power dissipation ⁽⁴⁾	500	mW
ESD	HBM: human body model ⁽⁵⁾	2	kV
	MM: machine model ⁽⁶⁾	200	V
	CDM: charged device model ⁽⁷⁾	1.5	kV

1. Either or both input voltages must not exceed the magnitude of V_{CC}^+ or V_{CC}^- .
2. This input current only exists when the voltage at any of the input leads is driven negative. It is due to the collector-base junction of the input PNP transistor becoming forward-biased and thereby acting as input diode clamp. In addition to this diode action, there is NPN parasitic action on the IC chip. This transistor action can cause the output voltages of the Op-amps to go to the V_{CC} voltage level (or to ground for a large overdrive) for the time during which an input is driven negative. This is not destructive and normal output is restored for input voltages above -0.3 V.
3. The junction base/substrate of the input PNP transistor polarized in reverse must be protected by a resistor in series with the inputs to limit the input current to 400 μ A max ($R = (V_{in} - 36 V)/400 \mu$ A).
4. Power dissipation must be considered to ensure maximum junction temperature (T_j) is not exceeded.
5. Human body model: 100 pF discharged through a 1.5 k Ω resistor between two pins of the device, done for all couples of pin combinations with other pins floating.
6. Machine model: a 200 pF capacitor is charged to the specified voltage, then discharged directly between two pins of the device with no external series resistor (internal resistor < 5 Ω), done for all couples of pin combinations with other pins floating.
7. Charged device model: all pins plus package are charged together to the specified voltage and then discharged directly to the ground.

Table 2. Operating conditions

Symbol	Parameter	Value	Unit
V_{CC}	Supply voltage	± 2.5 to ± 15	V
T_{oper}	Operating free-air temperature range	-40 to 105	°C

2 Typical application schematics

Figure 1. Schematic diagram (1/2 LM833)

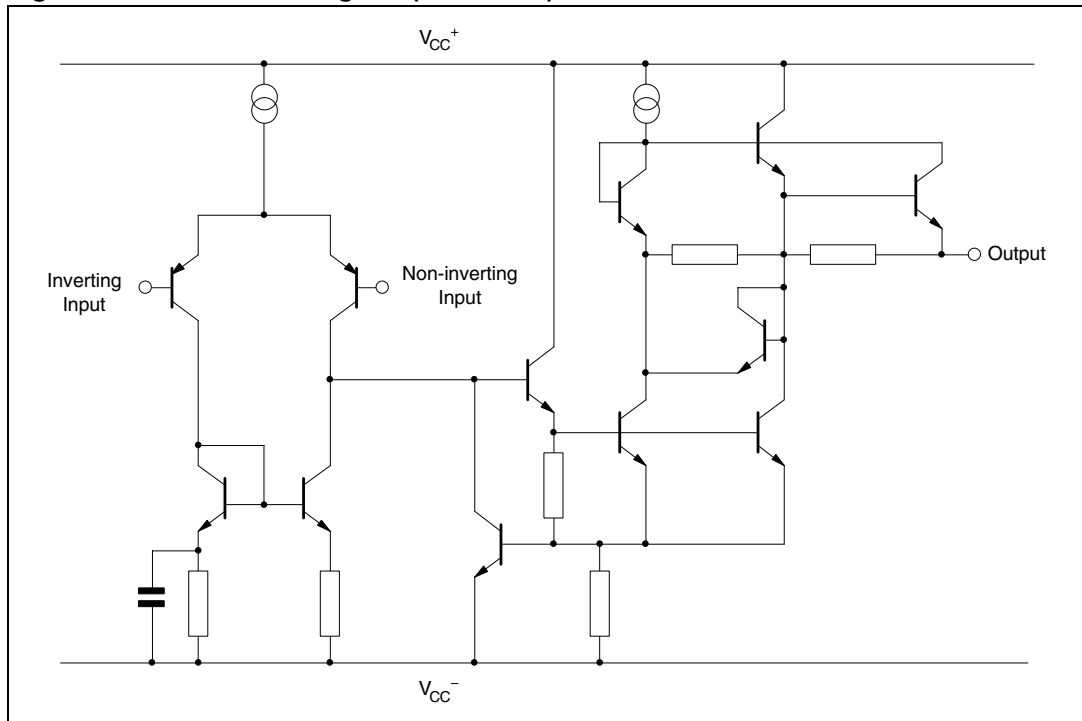

3 Electrical characteristics

Table 3. $V_{CC+} = +15\text{ V}$, $V_{CC-} = -15\text{ V}$, $T_{\text{amb}} = 25^\circ\text{ C}$ (unless otherwise specified)

Symbol	Parameter	Min.	Typ.	Max.	Unit
V_{io}	Input offset voltage ($R_S = 10\ \Omega$, $V_o = 0\text{ V}$, $V_{ic} = 0\text{ V}$)		0.3	5	mV
DV_{io}	Input offset voltage drift $R_S = 10\ \Omega$, $V_o = 0\text{ V}$, $T_{\text{min.}} \leq T_{\text{amb}} \leq T_{\text{max.}}$		2		$\mu\text{V}/^\circ\text{C}$
I_{io}	Input offset current ($V_o = 0\text{ V}$, $V_{ic} = 0\text{ V}$)		25	200	nA
I_{ib}	Input bias current ($V_o = 0\text{ V}$, $V_{ic} = 0\text{ V}$)		300	1000	nA
V_{icm}	Input common mode voltage range	± 12	± 14		V
A_{vd}	Large signal voltage gain ($R_L = 2\text{ k}\Omega$, $V_o = \pm 10\text{ V}$)	90	100		dB
$\pm V_{opp}$	Output voltage swing ($V_{id} = \pm 1\text{ V}$) $R_L = 2.0\text{ k}\Omega$ $R_L = 2.0\text{ k}\Omega$ $R_L = 10\text{ k}\Omega$ $R_L = 10\text{ k}\Omega$	10 12	13.7 -14 13.9 -14.4	-10 -12	V
CMR	Common-mode rejection ratio ($V_{ic} = \pm 13\text{ V}$)	80	100		dB
SVR	Supply voltage rejection ratio ($V_{CC+}/V_{CC-} = +15\text{ V}/-15\text{ V}$ to $+5\text{ V}/-5\text{ V}$)	80	105		dB
I_{CC}	Supply current ($V_o = 0\text{ V}$, all amplifiers)		4	8	mA
SR	Slew rate ($V_i = -10\text{ V}$ to $+10\text{ V}$, $R_L = 2\text{ k}\Omega$, $A_V = +1$)	5	7		V/ μs
GBP	Gain bandwidth product ($R_L = 2\text{ k}\Omega$, $C_L = 100\text{ pF}$, $f = 100\text{ kHz}$)	10	15		MHz
B	Unity gain bandwidth (open loop)		9		MHz
ϕ_m	Phase margin ($R_L = 2\text{ k}\Omega$)		60		Degrees
e_n	Equivalent input noise voltage ($R_S = 100\ \Omega$, $f = 1\text{ kHz}$)		4.5		$\frac{\text{nV}}{\sqrt{\text{Hz}}}$
i_n	Equivalent input noise current ($f = 1\text{ kHz}$)		0.5		$\frac{\text{pA}}{\sqrt{\text{Hz}}}$
THD	Total harmonic distortion ($R_L = 2\text{ k}\Omega$, $f = 20\text{ Hz}$ to 20 kHz , $V_o = 3\text{ V}_{\text{rms}}$, $A_V = +1$)		0.002		%
V_{O1}/V_{O2}	Channel separation ($f = 20\text{ Hz}$ to 20 kHz)		120		dB
FPB	Full power bandwidth ($V_o = 27\text{ V}_{\text{pp}}$, $R_L = 2\text{ k}\Omega$, $\text{THD} \leq 1\%$)		120		kHz

Figure 2. Total supply current vs. supply voltage

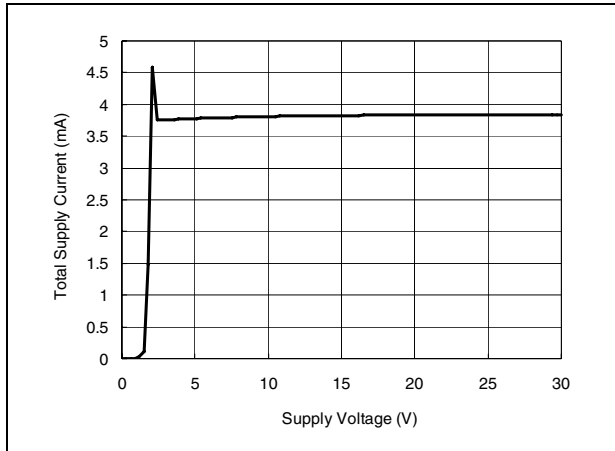

Figure 3. Output voltage vs. supply voltage

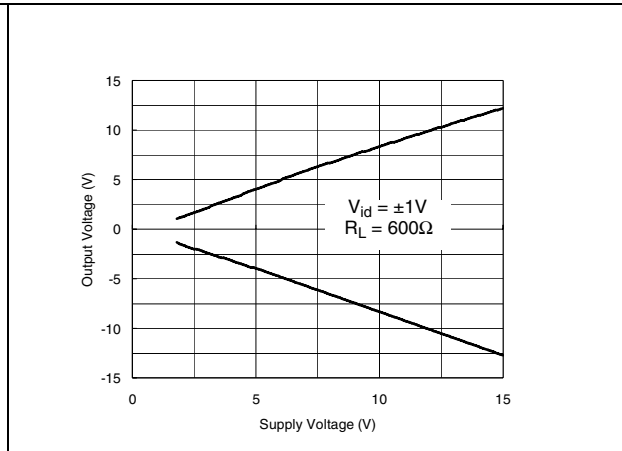

Figure 4. Equivalent input noise voltage vs. frequency

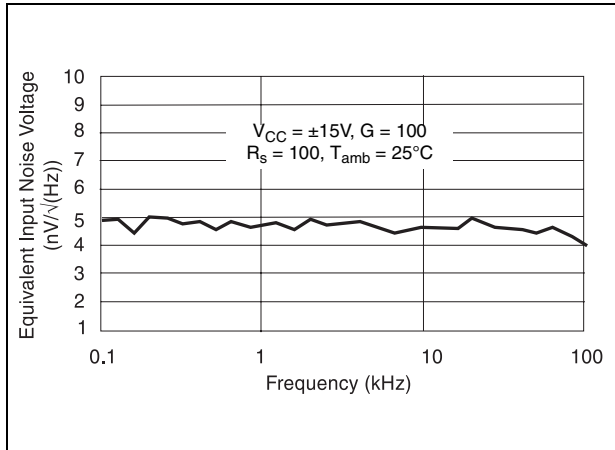

Figure 5. Output short circuit current vs. output voltage

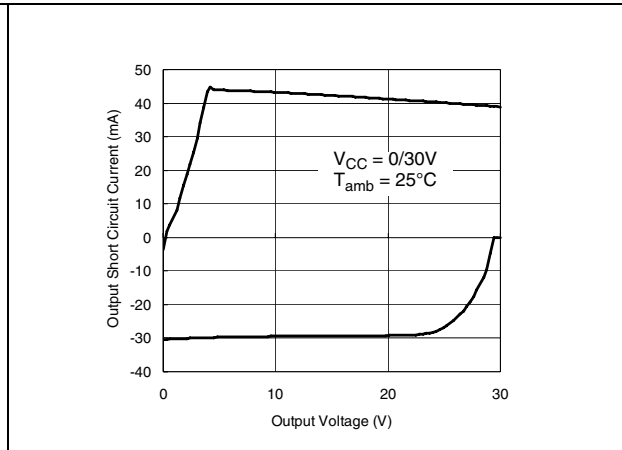

Figure 6. Output voltage vs. supply voltage

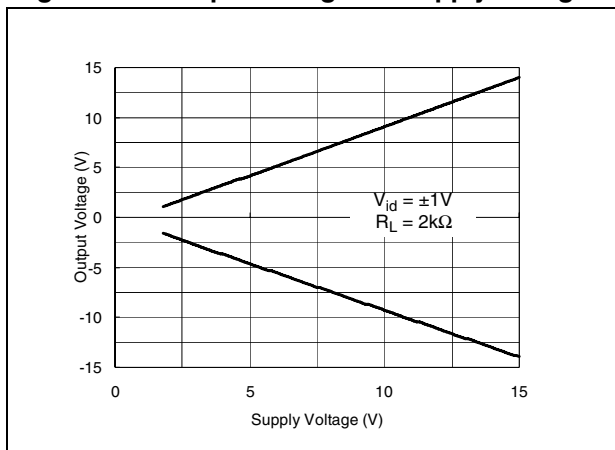

Figure 7. THD+ noise vs. frequency

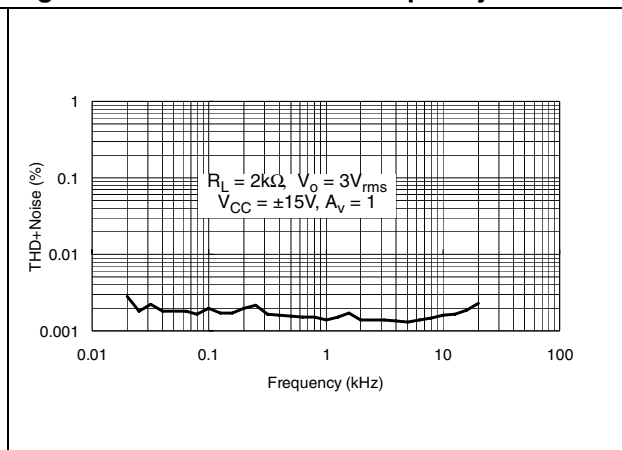

Figure 8. Voltage gain and phase vs. frequency

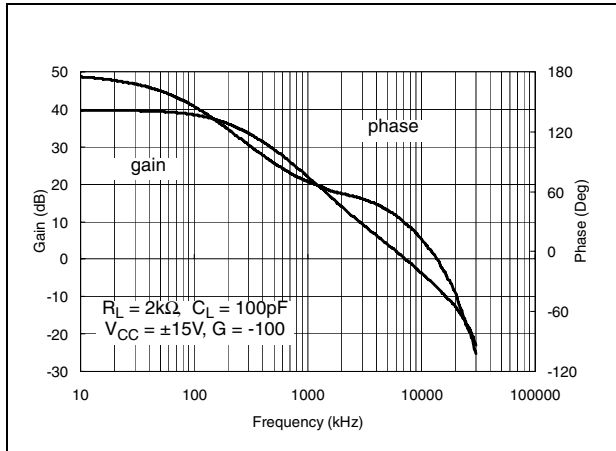
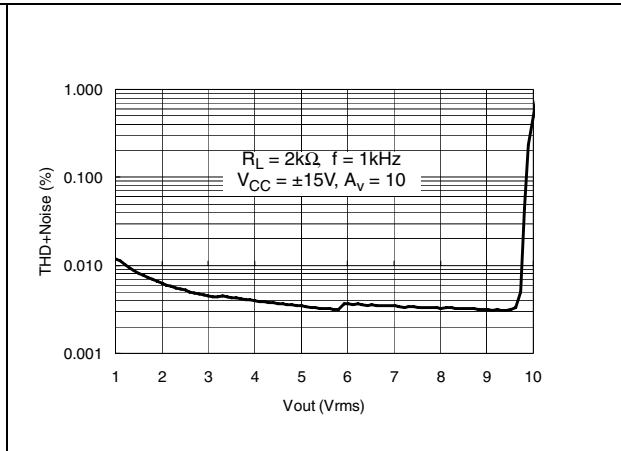

Figure 9. THD + noise vs. Vout



4 Package information

In order to meet environmental requirements, ST offers these devices in different grades of ECOPACK[®] packages, depending on their level of environmental compliance. ECOPACK[®] specifications, grade definitions and product status are available at: www.st.com. ECOPACK[®] is an ST trademark.

4.1 DIP8 package information

Figure 10. DIP8 package mechanical drawing

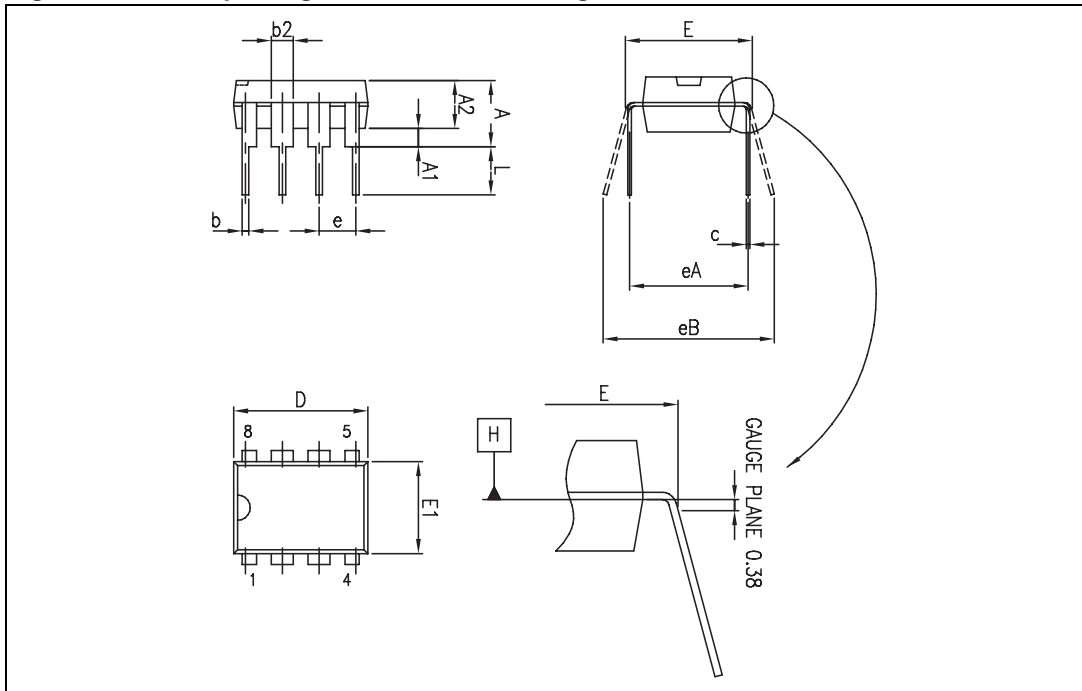

Table 4. DIP8 package mechanical data

Ref.	Dimensions					
	Millimeters			Inches		
	Min.	Typ.	Max.	Min.	Typ.	Max.
A			5.33			0.210
A1	0.38			0.015		
A2	2.92	3.30	4.95	0.115	0.130	0.195
b	0.36	0.46	0.56	0.014	0.018	0.022
b2	1.14	1.52	1.78	0.045	0.060	0.070
c	0.20	0.25	0.36	0.008	0.010	0.014
D	9.02	9.27	10.16	0.355	0.365	0.400
E	7.62	7.87	8.26	0.300	0.310	0.325
E1	6.10	6.35	7.11	0.240	0.250	0.280
e		2.54			0.100	
eA		7.62			0.300	
eB			10.92			0.430
L	2.92	3.30	3.81	0.115	0.130	0.150

4.2 SO-8 package information

Figure 11. SO-8 package mechanical drawing

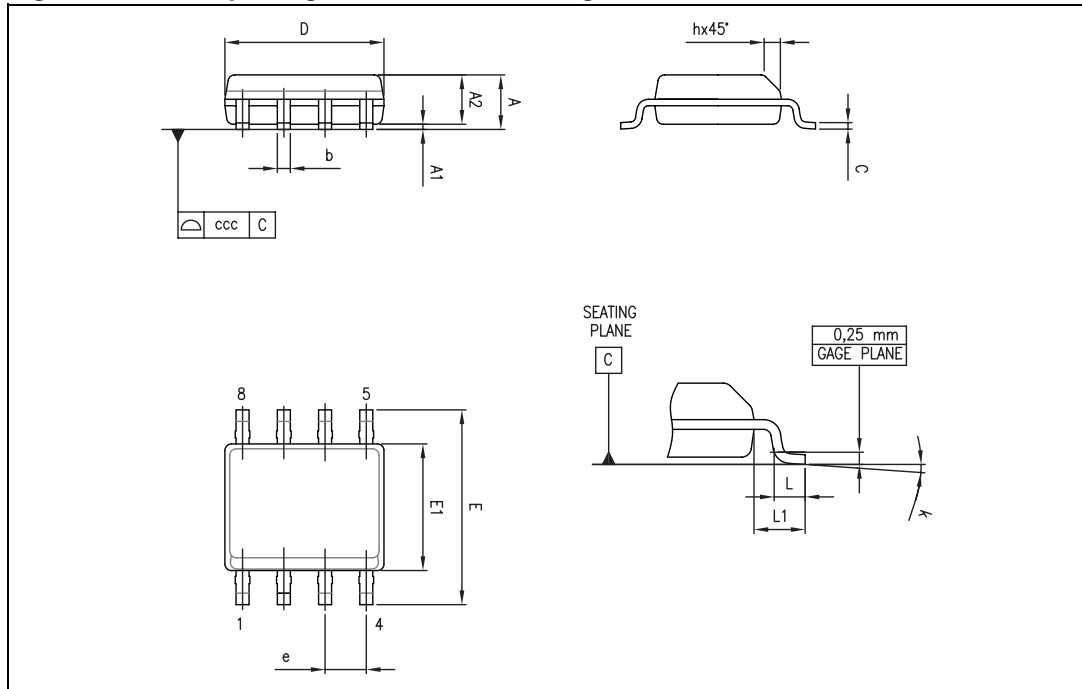

Table 5. SO-8 package mechanical data

Ref.	Dimensions					
	Millimeters			Inches		
	Min.	Typ.	Max.	Min.	Typ.	Max.
A			1.75			0.069
A1	0.10		0.25	0.004		0.010
A2	1.25			0.049		
b	0.28		0.48	0.011		0.019
c	0.17		0.23	0.007		0.010
D	4.80	4.90	5.00	0.189	0.193	0.197
E	5.80	6.00	6.20	0.228	0.236	0.244
E1	3.80	3.90	4.00	0.150	0.154	0.157
e		1.27			0.050	
h	0.25		0.50	0.010		0.020
L	0.40		1.27	0.016		0.050
L1		1.04			0.040	
k	0		8°	1°		8°
ccc			0.10			0.004

5 Ordering information

Table 6. Order codes

Part number	Temperature range	Package	Packing	Marking
LM833N	-40, +105° C	DIP8	Tube	LM833N
LM833D/DT		SO-8	Tube or tape & reel	833

6 Revision History

Table 7. Document revision history

Date	Revision	Changes
01-Nov-2001	1	Initial release.
01-Jul-2005	2	PPAP references inserted in the datasheet see Table on page 1 . ESD protection inserted in Table 1 on page 2 .
20-Aug-2009	3	Document reformatted. Minor text changes. Updated packages in Chapter 4: Package information . Removed automotive grade versions (LM833YD/DT) from Chapter 5: Ordering information

Please Read Carefully:

Information in this document is provided solely in connection with ST products. STMicroelectronics NV and its subsidiaries ("ST") reserve the right to make changes, corrections, modifications or improvements, to this document, and the products and services described herein at any time, without notice.

All ST products are sold pursuant to ST's terms and conditions of sale.

Purchasers are solely responsible for the choice, selection and use of the ST products and services described herein, and ST assumes no liability whatsoever relating to the choice, selection or use of the ST products and services described herein.

No license, express or implied, by estoppel or otherwise, to any intellectual property rights is granted under this document. If any part of this document refers to any third party products or services it shall not be deemed a license grant by ST for the use of such third party products or services, or any intellectual property contained therein or considered as a warranty covering the use in any manner whatsoever of such third party products or services or any intellectual property contained therein.

UNLESS OTHERWISE SET FORTH IN ST'S TERMS AND CONDITIONS OF SALE ST DISCLAIMS ANY EXPRESS OR IMPLIED WARRANTY WITH RESPECT TO THE USE AND/OR SALE OF ST PRODUCTS INCLUDING WITHOUT LIMITATION IMPLIED WARRANTIES OF MERCHANTABILITY, FITNESS FOR A PARTICULAR PURPOSE (AND THEIR EQUIVALENTS UNDER THE LAWS OF ANY JURISDICTION), OR INFRINGEMENT OF ANY PATENT, COPYRIGHT OR OTHER INTELLECTUAL PROPERTY RIGHT.

UNLESS EXPRESSLY APPROVED IN WRITING BY AN AUTHORIZED ST REPRESENTATIVE, ST PRODUCTS ARE NOT RECOMMENDED, AUTHORIZED OR WARRANTED FOR USE IN MILITARY, AIR CRAFT, SPACE, LIFE SAVING, OR LIFE SUSTAINING APPLICATIONS, NOR IN PRODUCTS OR SYSTEMS WHERE FAILURE OR MALFUNCTION MAY RESULT IN PERSONAL INJURY, DEATH, OR SEVERE PROPERTY OR ENVIRONMENTAL DAMAGE. ST PRODUCTS WHICH ARE NOT SPECIFIED AS "AUTOMOTIVE GRADE" MAY ONLY BE USED IN AUTOMOTIVE APPLICATIONS AT USER'S OWN RISK.

Resale of ST products with provisions different from the statements and/or technical features set forth in this document shall immediately void any warranty granted by ST for the ST product or service described herein and shall not create or extend in any manner whatsoever, any liability of ST.

ST and the ST logo are trademarks or registered trademarks of ST in various countries.

Information in this document supersedes and replaces all information previously supplied.

The ST logo is a registered trademark of STMicroelectronics. All other names are the property of their respective owners.

© 2009 STMicroelectronics - All rights reserved

STMicroelectronics group of companies

Australia - Belgium - Brazil - Canada - China - Czech Republic - Finland - France - Germany - Hong Kong - India - Israel - Italy - Japan - Malaysia - Malta - Morocco - Philippines - Singapore - Spain - Sweden - Switzerland - United Kingdom - United States of America

www.st.com

X-ON Electronics

Largest Supplier of Electrical and Electronic Components

Click to view similar products for [Audio Amplifiers](#) category:

Click to view products by [STMicroelectronics](#) manufacturer:

Other Similar products are found below :

[LV47002P-E](#) [NCP2811AFCT1G](#) [NCP2890AFCT2G](#) [SSM2377ACBZ-R7](#) [IS31AP4915A-QFLS2-TR](#) [NCP2820FCT2G](#) [TDA1591T](#)
[TDA7563AH](#) [SSM2529ACBZ-R7](#) [SSM2518CBZ-R7](#) [MAX9890AETA+T](#) [TS2012EIJT](#) [NCP2809BMUTXG](#) [NJW1157BFC2](#)
[SSM2375CBZ-REEL7](#) [IS31AP4996-GRLS2-TR](#) [STPA002OD-4WX](#) [NCP2823BFCT1G](#) [MAX9717DETA+T](#) [MAX9717CETA+T](#)
[MAX9724AEBC+TG45](#) [LA4450L-E](#) [IS31AP2036A-CLS2-TR](#) [MAX9723DEBE+T](#) [TDA7563ASMTR](#) [AS3561-DWLT](#) [SSM2517CBZ-R7](#)
[MP1720DH-12-LF-P](#) [SABRE9601K](#) [THAT1646W16-U](#) [MAX98396EWB+](#) [PAM8965ZLA40-13](#) [BD37532FV-E2](#) [BD5638NUX-TR](#)
[BD37512FS-E2](#) [BD37543FS-E2](#) [BD3814FV-E2](#) [TPA3140D2PWPR](#) [TS2007EIJT](#) [IS31AP2005-DLS2-TR](#) [SSM2518CPZ-R7](#) [AS3410-EQFP-](#)
[500](#) [FDA4100LV](#) [MAX98306ETD+T](#) [TS4994EIJT](#) [NCP2820FCT1G](#) [NCP2823AFCT2G](#) [NCS2211MNTXG](#) [CPA2233CQ16-A1](#)
[OPA1604AIPWR](#)