



# LNBP8L - LNBP9L LNBP10L - LNBP11L

## LNB supply and control voltage regulator

Preliminary data

### Features

- Simplest integrated solution for LNB remote supply and control
- 500 mA guaranteed output current
- Dual input supply for reducing power dissipation (DFN package)
- 3-state function to enable/disable and select the output voltage level through a single pin
- Fast oscillator startup for DiSEq™ encoding (LNBP9L/11L versions)
- External 22 kHz modulation input pin (LNBP8L/10L versions)
- Cable length compensation, LLC pin (LNBP10L, LNBP11L versions)
- Short-circuit and over-temperature protection
- LNB overload and short-circuit dynamic protection (LNBP10L, LNBP11L versions)
- Available in DFN8 (5 x 6 mm) and IPPAK packages

### Description

Intended for analog and digital satellite receivers, the LNBP is a monolithic linear voltage regulator, assembled in the DFN8 5x6 and IPPAK packages, specifically designed to provide the powering voltages and the interfacing signals to the LNB down-converter. The regulator output can be logic controlled for 13 V or 18 V (typ.) by means of the EN/VSEL 3-state pin for remotely controlling the LNB. When the IC is powered and put in standby (EN/VSEL pin at high impedance), the regulator output is disabled. In order to reduce power dissipation, the LNBP10L/11L versions (on DFN package) feature 2 supply inputs:  $V_{CC1}$  and  $V_{CC2}$ . These pins must be powered, respectively, at 15 V (min.) and 22 V (min.), and an internal switch will automatically select the appropriate supply voltage according to the selected output voltage. The LNBP8L/9L versions (in the IPPAK package) have only one supply input pin, which must be

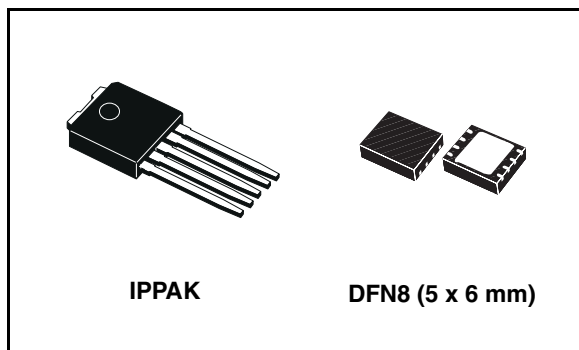

supplied at 22 V (min.). Additionally, the LNBP10L/11L versions have the LLC pin to increment the selected output voltage value by 1 V (typ.) to compensate for the excess voltage drop along the coaxial cable (LLC pin HIGH).

An analog 22 kHz modulation input pin (EXTM) is available in the LNBP8L and LNBP10L versions. An appropriate DC blocking capacitor must be used to couple the modulating signal source to the EXTM pin. The LNBP10L/11L versions are also equipped with over-current dynamic protection: as soon as an overload is detected the output is shut down for the time  $T_{OFF}$ , which is determined by the capacitor connected between the CEXT pin and GND. After the time has elapsed, the output is resumed for a time  $T_{ON} = (1/12) * T_{OFF}$  (typ.). If the overload is still present, the protection circuit will cycle again through  $T_{OFF}$  and  $T_{ON}$  until the overload is removed. A typical  $T_{ON} + T_{OFF}$  value is 1100 ms when a 4.7  $\mu$ F external capacitor is used on the  $C_{EXT}$ . This dynamic operation can greatly reduce the power dissipation in short-circuit condition, while ensuring excellent power-on startup even with highly capacitive loads on the LNB outputs. The device is packaged in the IPPAK for through-hole mounting and in the DFN8 5x6 for surface mounting. Both package solutions are offered in two versions: with ten pins (LNBP9L/11L) to use with the integrated 22 kHz tone generator, or with the EXTM pin (LNBP8L/10L) to use external 22 kHz sources. All versions have built-in thermal protection to prevent overheating damage.

# Contents

1	<b>Diagram</b> .....	<b>3</b>
2	<b>Pin configuration</b> .....	<b>4</b>
3	<b>Maximum ratings</b> .....	<b>5</b>
4	<b>Electrical characteristics</b> .....	<b>6</b>
5	<b>Typical application circuits</b> .....	<b>8</b>
6	<b>Detailed description and application hints</b> .....	<b>9</b>
	6.1 Input voltage protection .....	10
	6.2 Single supply for the DFN package .....	11
	6.3 IPPAK mounting and thermal considerations .....	11
7	<b>Typical performance characteristics</b> .....	<b>13</b>
8	<b>Package mechanical data</b> .....	<b>16</b>
9	<b>Ordering information</b> .....	<b>19</b>
10	<b>Revision history</b> .....	<b>20</b>

# 1 Diagram

Figure 1. Block diagram

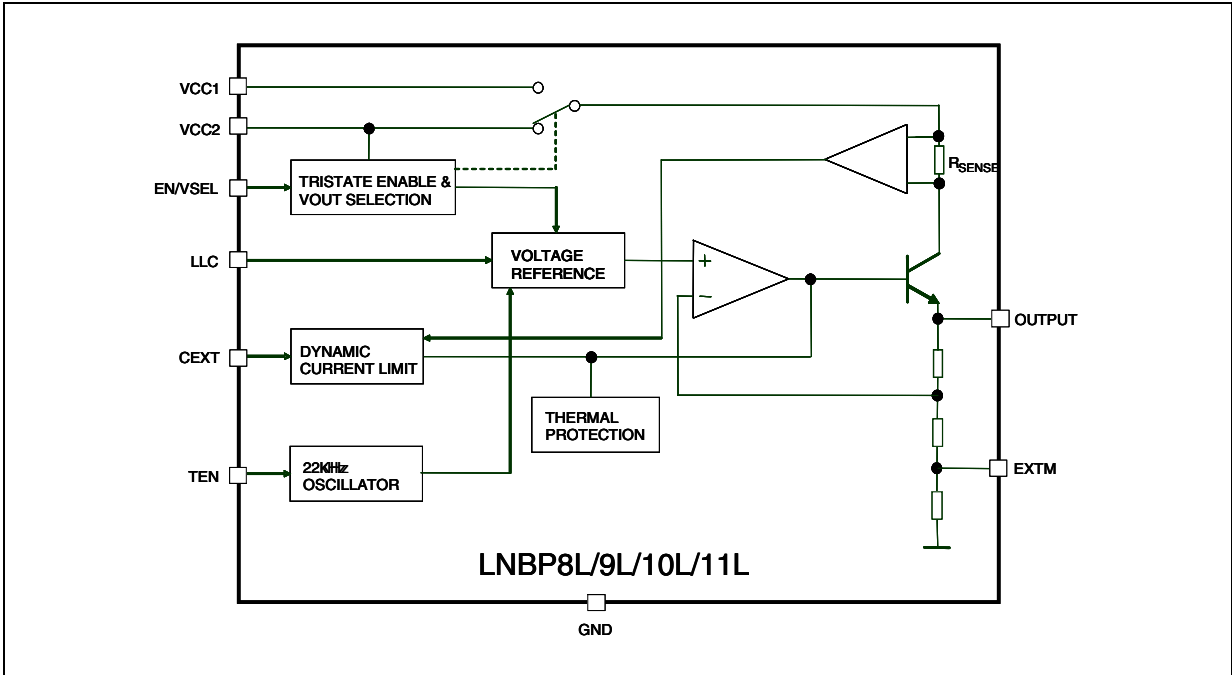

## 2 Pin configuration

Figure 2. Pin connections (top view for IPPAK, bottom view for DFN8)

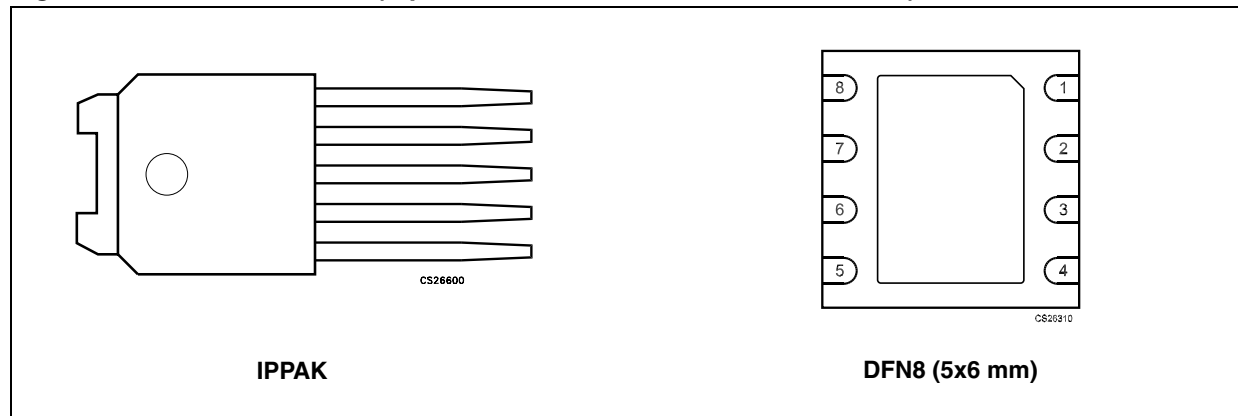

Table 1. Pin description

Pin n° (DFN) LNBP10/11L	Pin n° (IPPAK) LNBP8/9L	Name	Pin function
1	-	VCC1 (not available for IPPAK)	<b>Supply input 1:</b> 15 V to 25 V supply. For DFN package it is automatically selected when $V_{OUT} = 13$ V. For IPPAK package $V_{CC1}$ and $V_{CC2}$ are internally connected together to pin 1 to be supplied at 22 V min.
2	1	VCC2 ( $V_{CC}$ pin for IPPAK)	<b>Supply input 2:</b> 22 V to 25 V supply. For DFN package it is automatically selected when $V_{OUT} = 18$ V. For IPPAK package $V_{CC1}$ and $V_{CC2}$ are internally connected together to the pin 1 to be supplied at 22 V min.
3	2	OUTPUT	<b>Output:</b> regulator output. It is 13 V typ when EN/VSEL LOW and 18 V typ when EN/VSEL HIGH.
4, ePAD	3, ePAD	GROUND	GROUND
6	4	EN/VSEL	<b>Enable and output voltage selection 3-state pin:</b> logic control input 3-state pin for the remote controlling of the LNB; if LOW $V_{OUT} = 13$ V, when HIGH $V_{OUT} = 18$ V, if left at high impedance the IC is set in shut down mode ( $V_{OUT} = 0$ V)
5	5	EXTM/TEN	<b>Tone enable (LNBP9-11):</b> logic control input to enable internal tone generator. <b>External modulation (LNBP8-10):</b> Needs DC decoupling to the AC source. If not used can be left floating.
8	NA	LLC	<b>LLC:</b> logic control input to add 1 V typ.
7	NA	$C_{EXT}$	<b><math>C_{EXT}</math>:</b> timing capacitor used by the dynamic overload protection. Typical application is 4.7 $\mu$ F for a 1100 ms cycle

### 3 Maximum ratings

**Table 2. Absolute maximum ratings**

Symbol	Parameter	Value	Unit
VCC1, VCC2	Input voltages	-0.3 to 28	V
VCC1-OUTPUT	VCC1 voltage with respect to OUTPUT voltage <sup>(1)</sup>	-0.3 to 25	V
VCC2-OUTPUT	VCC2 voltage with respect to OUTPUT voltage <sup>(1)</sup>	-0.3 to 25	V
EN/VSEL, TEN, LLC	Logic input voltage	-0.3 to 7	V
EXTM	External modulation input voltage	-0.3 to 1	V
OUTPUT	Output voltage	-0.3 to 25	V
T <sub>STG</sub>	Storage temperature range	-50 to 150	°C
ESD DFN package	ESD rating with human body model (HBM) for all pins except 1, 2, 6	2	kV
	ESD rating with human body model (HBM) for pins 1, 2, 6	1.5	
ESD IPPAK package	ESD rating with human body model (HBM) for all pins except 1, 4	2	kV
	ESD rating with human body model (HBM) for pins 1, 4	1.5	

1. Exposure beyond the VCC1 and VCC2 with respect to OUTPUT absolute-maximum-rated voltages during OUTPUT pin overload or short-circuit to GROUND may cause permanent damage to the device.

*Note: Absolute maximum ratings are those values beyond which damage to the device may occur. These are stress ratings only and functional operation of the device at these conditions is not implied. Exposure to absolute-maximum-rated conditions for extended periods may affect device reliability. All voltage values are with respect to network ground terminal unless otherwise stated.*

**Table 3. Operating ratings**

Symbol	Parameter	Value	Unit
T <sub>J</sub>	Operating junction temperature range	0 to 125	°C
VCC1	Input voltage	15 to 25	V
VCC2	Input voltage	22 to 25	V

**Table 4. Thermal data**

Symbol	Parameter	IPPAK	DFN8	Unit
R <sub>thJA</sub>	Thermal resistance junction-ambient		35 (mounted on PCB 2s2p)	°C/W
R <sub>thJC</sub>	Thermal resistance junction-case	8		°C/W

## 4 Electrical characteristics

**Table 5. Electrical characteristics**

Refer to the typical application circuits in [Figure 3](#) and [Figure 4](#),  $V_{CC1} = 16\text{ V}$ ,  $V_{CC2} = 23\text{ V}$  <sup>(1)</sup>, EN/VSEL = LOW, TEN = LLC = LOW, EXTM = FLOATING,  $I_{OUT} = 50\text{ mA}$ ,  $T_J = 0\text{ }^{\circ}\text{C}$  to  $85\text{ }^{\circ}\text{C}$ , unless otherwise stated. Typical values are referred to  $T_J = 25\text{ }^{\circ}\text{C}$

Symbol	Parameter	Test conditions	Min	Typ	Max	Unit
$V_{CC1}$	$V_{CC}$ supply input 1 <sup>(1)</sup>	$I_{OUT} = 500\text{ mA}$ , TEN=HIGH, EN/VSEL=LOW, LLC=LOW	15		25	V
		$I_{OUT} = 500\text{ mA}$ , TEN=HIGH, EN/VSEL=LOW, LLC= HIGH	16		25	
$V_{CC2}$	$V_{CC}$ supply input 2 <sup>(1)</sup>	$I_{OUT} = 500\text{ mA}$ , TONE=HIGH, EN/VSEL=HIGH, LLC=LOW	22		25	V
		$I_{OUT} = 500\text{ mA}$ , TONE=HIGH, EN/VSEL=HIGH, LLC= HIGH	23		25	
$V_{OUT}$	Output voltage	$I_{OUT} = 500\text{ mA}$ , EN/VSEL=LOW	12.5	13.25	14	V
		$I_{OUT} = 500\text{ mA}$ , EN/VSEL=HIGH	17	18	19	V
		$I_{OUT} = 500\text{ mA}$ , EN/VSEL=LOW, LLC=HIGH <sup>(2)</sup>		14.25		V
		$I_{OUT} = 500\text{ mA}$ , EN/VSEL=LLC=HIGH <sup>(2)</sup>		19		V
$\Delta V_{OUT}$	Line regulation <sup>(1)</sup>	$V_{CC1}$ from 15 V to 18 V, EN/VSEL=LOW or HIGH		5	40	mV
$\Delta V_{OUT}$	Load regulation	$V_{CC1} = V_{CC2} = 22\text{ V}$ , $I_{OUT}$ from 50 mA to 500 mA, EN/VSEL=LOW or HIGH		50	150	mV
$I_{MAX}$	Output current limiting		550	700	850	mA
$F_{TONE}$	Tone frequency	TEN=High	20	22	24	kHz
$A_{TONE}$	Tone amplitude	TEN=High	0.4	0.65	0.9	$V_{PP}$
$D_{TONE}$	Tone duty cycle	TEN=High	40	50	60	%
$t_r, t_f$	Tone Rise and Fall Time	TEN=High <sup>(3)</sup>	5	10	15	$\mu\text{s}$
$G_{EXTM}$	External modulation Gain	$\Delta V_{OUT}/\Delta V_{EXTM}$ , freq. from 10 kHz to 40 kHz	4.5	5.5	6.5	
$V_{EXTM}$	External modulation input voltage	AC Coupling			400	$\text{mV}_{PP}$
$Z_{EXTM}$	External modulation impedance	Freq. from 10 kHz to 40 kHz		400		$\Omega$
$V_{ILT}$	Control input logic LOW threshold for 3-state pin	EN/VSEL	0.8	1	1.2	V
$V_{IHT}$	Control input logic HIGH threshold for 3-state pin	EN/VSEL	1.8	2	2.2	V
$I_{IHT}$	3-state control pin input current HIGH	$V_{IHT} = 5\text{ V}$ , EN/VSEL		-400		$\mu\text{A}$

**Table 5. Electrical characteristics (continued)**

Refer to the typical application circuits in [Figure 3](#) and [Figure 4](#),  $V_{CC1} = 16\text{ V}$ ,  $V_{CC2} = 23\text{ V}$  <sup>(1)</sup>, EN/VSEL = LOW, TEN = LLC = LOW, EXTM = FLOATING,  $I_{OUT} = 50\text{ mA}$ ,  $T_J = 0\text{ }^{\circ}\text{C}$  to  $85\text{ }^{\circ}\text{C}$ , unless otherwise stated. Typical values are referred to  $T_J = 25\text{ }^{\circ}\text{C}$

Symbol	Parameter	Test conditions	Min.	Typ.	Max.	Unit
$I_{ILT}$	3-state control pin input current LOW	$V_{ILT} = 0\text{ V}$ , EN/VSEL		+180		$\mu\text{A}$
$V_{IL}$	Control input logic LOW	TEN, LLC			0.8	V
$V_{IH}$	Control input logic HIGH	TEN, LLC	2.5			V
$I_{IH}$	Control pins input current	$V_{IH} = 5\text{ V}$ , TEN, LLC		20		$\mu\text{A}$
$I_{CC}$	Supply current	Output disabled EN/VSEL=High impedance (floating)		1.7	2.4	mA
		Output enabled EN/VSEL=HIGH, TEN=HIGH, $I_{OUT} = 500\text{ mA}$		3.7	6.3	mA
$T_{OFF}$	Dynamic overload protection OFF time	Output shorted, $C_{EXT} = 4.7\text{ }\mu\text{F}$ <sup>(2)</sup>		1000		ms
$T_{ON}$	Dynamic overload protection ON time	Output shorted, $C_{EXT} = 4.7\text{ }\mu\text{F}$ <sup>(2)</sup>		$T_{OFF}/12$		ms
$I_{OBK}$	Output backward current	Output forced to 21 V		6		mA
$T_{SHDN}$	Thermal shutdown threshold			165		$^{\circ}\text{C}$
$\Delta T_{SHDN}$	Thermal shutdown hysteresis			25		$^{\circ}\text{C}$

1. For IPPAK package  $V_{CC1}$  and  $V_{CC2}$  are internally connected to the pin 1 ( $V_{CC}$ ) to be supplied in the range from 22 V up to 25 V
2. Only DFN package
3. Guaranteed by design

## 5 Typical application circuits

Figure 3. Single input supply voltage solution for IPPAK package versions

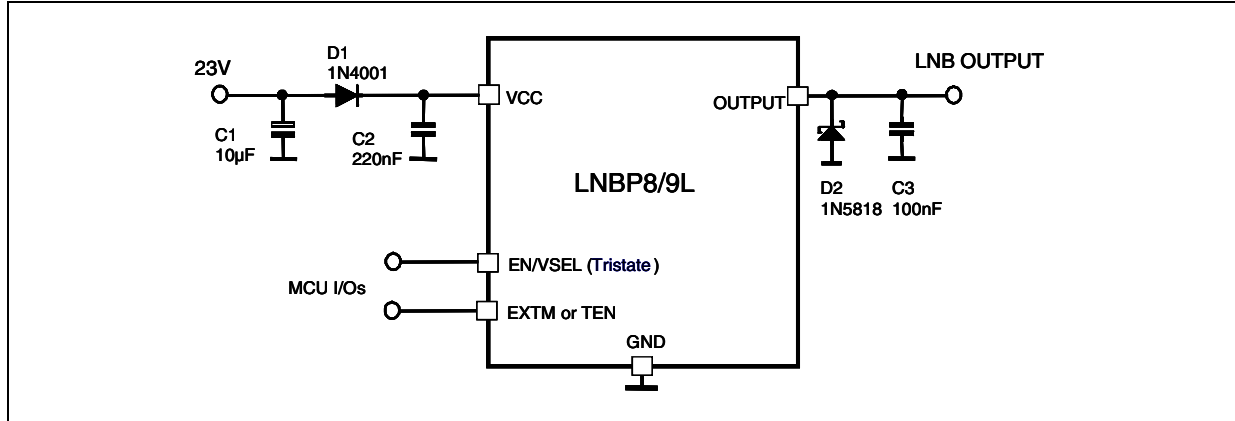

Figure 4. Dual input supply voltage solution for DFN8 (5 x 6 mm) package versions

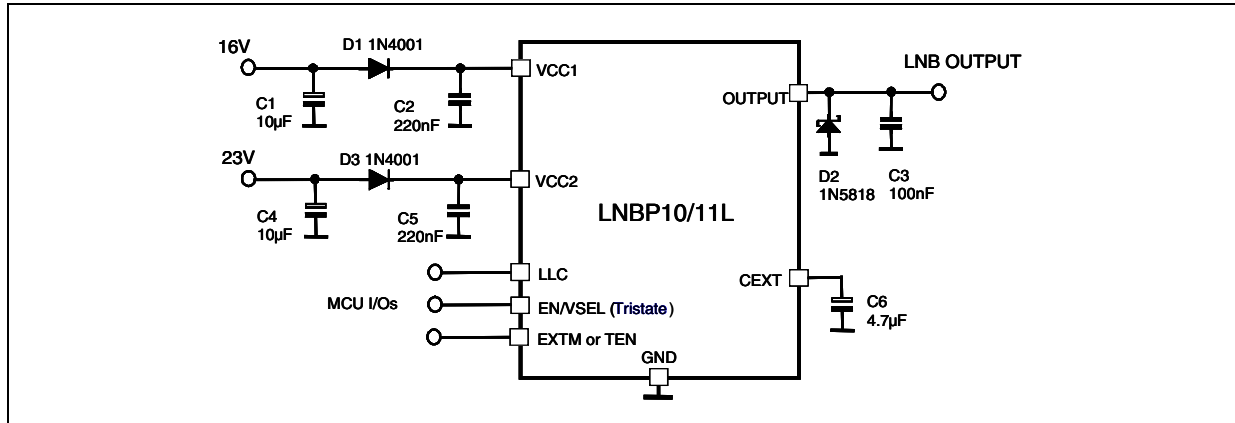
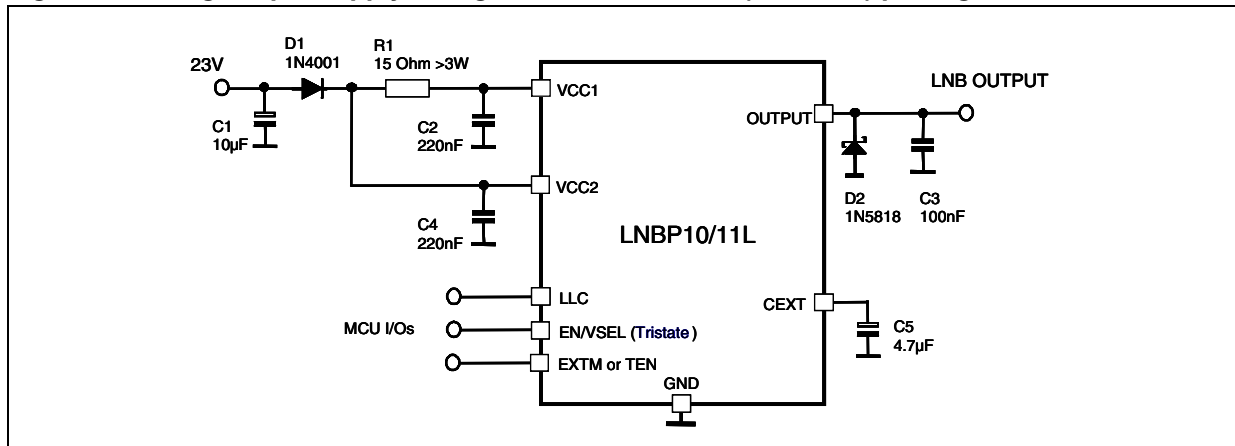

Figure 5. Single input supply voltage solution for DFN8 (5 x 6 mm) package versions



Note: In a single supply configuration with the DFN package, an  $R_1$  resistor in the 12-15  $\Omega$  range is recommended to reduce device power dissipation during the 13 V output condition. The resistor can be omitted, but the power dissipation will increase.



## 6 Detailed description and application hints

The LNBPxx is made up of several functional blocks (see [Figure 1 on page 3](#)), as described below:

1. The oscillator is activated by setting the ENT pin (enable tone) = H, and is factory-trimmed at 22 kHz  $\pm$  2 kHz, eliminating the need to use external trimming. The rising and falling edges are maintained in the 5 to 15  $\mu$ s range (10  $\mu$ s typ.), to avoid RF pollution of the receiver. The duty cycle is 50% typ. It modulates the DC output with a  $\pm$  0.325 V typ. amplitude and 0 V average. The presence of this signal usually gives the LNB information about the band to be received.
2. The 3-state enable & V<sub>OUT</sub> selection block, selects the two output voltages or sets the IC to shutdown mode, depending on the voltage applied on the EN/VSEL pin. When EN/VSEL is set high (EN/VSEL > 2.2 V), an 18 V output voltage is selected; when the EN/VSEL is set low (EN/VSEL < 0.8 V), a 13 V output voltage is selected. If the EN/VSEL pin is left floating (high impedance) or if the pin is set in a range from 1.2 V to 1.8 V (1.5 V typ.), the IC goes into shutdown mode and the output voltage will be set to 0 V.  
This feature changes the LNB polarization type. The LNB switches to horizontal or vertical polarization depending on the supply voltage it gets from the receiver.
3. For the DFN package, in order to keep the power dissipation of the device as low as possible, the input selector automatically selects V<sub>CC1</sub>; that is, the lowest input voltage, when 13 V output is selected (i.e. EN/VSEL is low). If the 18 V output is selected (i.e. EN/VSEL is high), the V<sub>CC2</sub> input pin is selected. For example, power dissipation at I<sub>OUT</sub> = 350 mA is:

$$P_D = (23 - 18) \times 0.35 = 1.75 \text{ W}$$

with V<sub>CC2</sub> = 23 V (voltage on the V<sub>CC2</sub> pin) and V<sub>OUT</sub> = 18 V, and

$$P_D = (16 - 13) \times 0.35 = 1.05 \text{ W}$$

with V<sub>CC1</sub> = 16 V (voltage on the V<sub>CC1</sub> pin) and V<sub>OUT</sub> = 13 V

For IPPAK package, V<sub>CC1</sub> and V<sub>CC2</sub> are internally connected and must be supplied from a single input voltage line (22 V min.) to the V<sub>CC</sub> pin. In this case the worst case power dissipation is 13 V output. For example: at I<sub>OUT</sub> = 350 mA and V<sub>CC</sub> = 23 V (voltage on the V<sub>CC</sub> pin):

$$P_D = (23 - 13) \times 0.35 = 3.5 \text{ W}$$

4. The line length compensation function is useful when the antenna is connected to the receiver by a long coaxial cable that adds a considerable DC voltage drop. When the LCC pin is H, the output voltage selected is increased by about 1 V. This function is available for the DFN package only.
5. The reference drives all the internal blocks that require a high-precision thermally compensated voltage source.
6. The LNBPxx has two different protection features, and both turn off the outputs. The first one protects against overheating (i.e. for T<sub>J</sub>  $\geq$  150 °C), and the second against overload conditions (i.e. for output current > 550 mA) or short-circuit:
  - a) In the thermal protection case the output is disabled until the chip temperature has fallen below 140 °C typ. and the LNBPxx output is restored.
  - b) The overload protection case occurs when output current request is  $\geq$  500 mA. For the DFN package only, the IC features dynamic overload and short-circuit

protection. When an overload occurs the device limits the output current for the time  $T_{ON}$  depending on the  $C_{EXT}$  value (see [Figure 24](#) and [Figure 25](#)). When  $T_{ON}$  has elapsed, the output goes low for a time of  $T_{OFF} = 12 \times T_{ON}$ . This keeps the power dissipated by the device low in overload conditions, and avoids the need for an oversized heat sink in this condition. For the IPPAK package, when the overload or the short-circuit occurs, the device clamps the output current in a range between 550 mA and 850 mA.

7. EXT<sub>TM</sub> modulates the  $V_{OUT}$  by means of a capacitor connected in series (see [Figure 6](#)). The following equation is used to calculate the peak-to-peak voltage of  $V_{OUT}$ :

$$V_{OUT(AC)} = V_{EXTM(AC)} \times G_{EXTM}$$

where  $V_{OUT(AC)}$  and  $V_{EXTM(AC)}$  are, respectively, the peak-to-peak voltage of  $V_{OUT}$  and  $V_{EXTM}$ .  $G_{EXTM}$  is the external modulation gain.

**Figure 6. EXT<sub>TM</sub> application circuit**

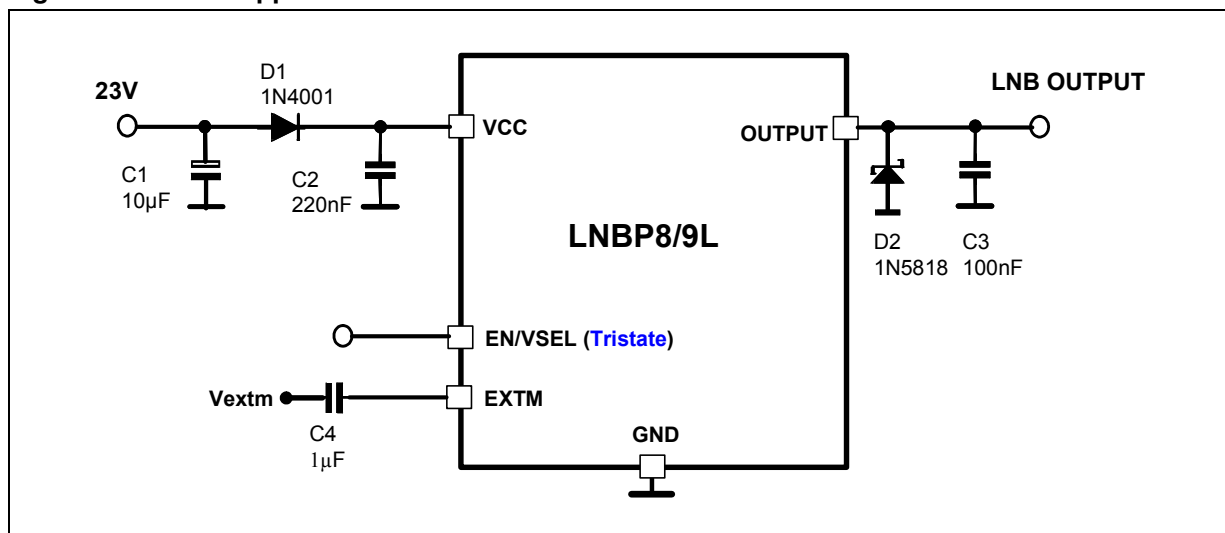

## 6.1 Input voltage protection

In some cases two or more receivers share the same coaxial cable, rendering their outputs hard-paralleled, so the same voltage is present at the outputs of the receivers. If a receiver is not disconnected at the mains, a current will flow from the OUTPUT to the  $V_{CC1}$  or  $V_{CC2}$  pins, depending the EN/VSEL pin setting. To avoid this, two diodes (only one for the IPPAK package) in series are recommended at input pins  $V_{CC1}$  and  $V_{CC2}$  (see [Figure 3](#)). These diodes do not cause a change at  $V_{OUT}$ , but only a voltage drop, which can be minimized by using Schottky diodes. Diodes used in [Figure 4](#) and [Figure 5](#) must withstand a continuous current of almost 1 A and a breakdown voltage of 30 V (suggested type is 1N4001 or BYV10-30). Be aware that the minimum voltage needed at the  $V_{CC}$  pins must be respected, considering the voltage drop across the input diodes).

## 6.2 Single supply for the DFN package

If only one power supply source is available, the  $V_{CC1}$  and  $V_{CC2}$  pins can be powered by the same power source without affecting the performance of other circuits, at the cost of higher power losses in the device and higher heat sink surface. Also, in order to reduce the power dissipation in the device, an appropriate-value resistor can be inserted in series with the  $V_{CC1}$  line (see [Figure 5](#)). This resistor must be dimensioned considering that the minimum voltage on the  $V_{CC1}$  pin must be  $\geq 16$  V (15 V if LLC is not used).

For example, with  $I_{OUT} = 500$  mA:

$$R \leq \frac{(23 - V_f - 16)}{500 \times 10^{-3}} \cong 12 \Omega$$

Where  $V_f$  is the forward voltage of the input diode D1 (see [Figure 5](#)).

Power dissipated in this resistor is:

$$P_D = R * I_{OUT}^2 = 12 * (500 * 10^{-3})^2 = 3 \text{ W}$$

It is recommended to bypass the  $V_{CC1}$  and  $V_{CC2}$  pins using 220 nF electrolytic capacitors.

## 6.3 IPPAK mounting and thermal considerations

First, it should be noted that the tab is directly connected to the GND pin, so care must be taken when the device is connected to a heat-sink. If the heat sink is at a different voltage than the ground, an electrical insulator must be added between the tab and the heat sink at the cost of an increase in the thermal resistance. For better thermal performance, an isolated heat sink or connection to ground is recommended.

Several clips can be used depending on the heat sink type:

- Saddle clips ([Figure 7](#)) for slim heat sinks
- U-clips ([Figure 8](#)) for thick heat sinks
- Dedicated clips for special shaped heat sinks

**Figure 7. IPPAK mounted with a saddle clip.**

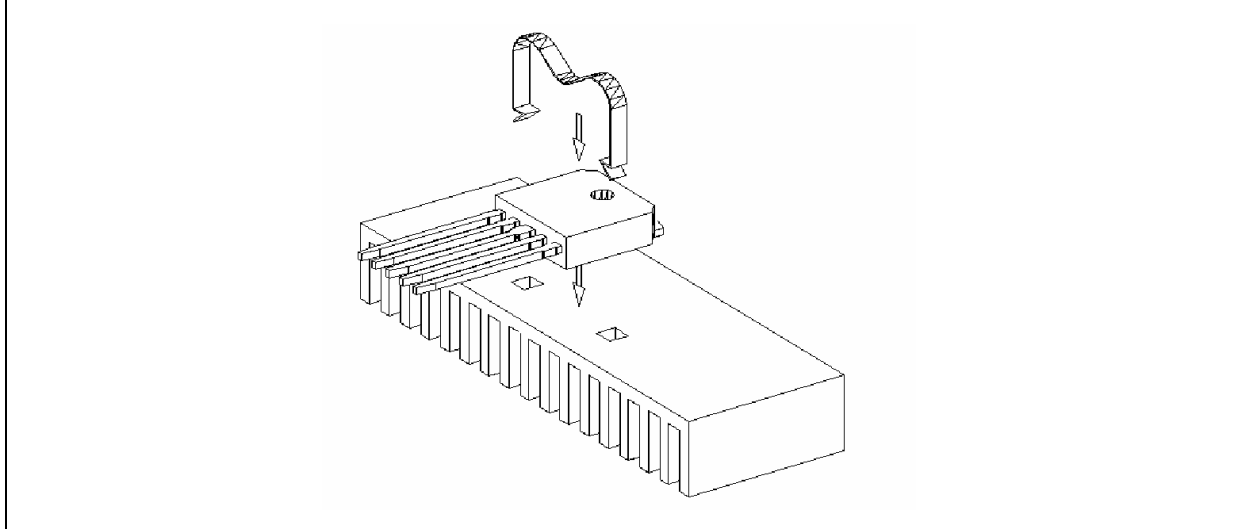

**Figure 8. IPPAK mounted with a U-clip.**

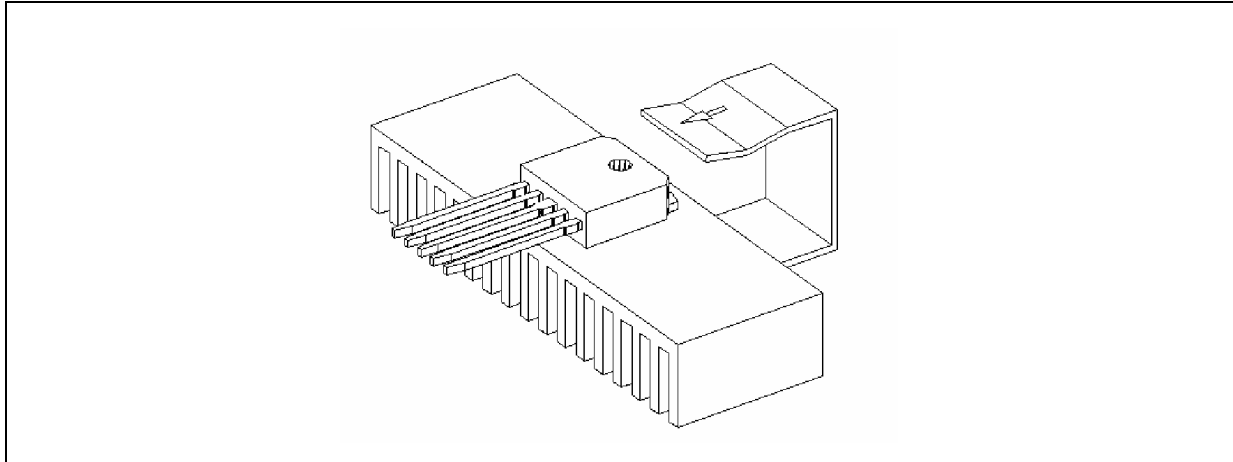

Note that the thickness of the IPPAK package (2.3 +/- 0.1 mm) is similar to that of the SOT-32 and SOT-82 (2.55 +/- 0.15 mm). The same clips can also be used for these packages.

The junction-to-ambient thermal resistance for the IPPAK can be calculated as follows:

$$R_{TH-JA} = R_{TH-JC} + R_{TH-CH} + R_{TH-HA}$$

where:  $R_{TH-JC}$  is the junction-to-case thermal resistance of the IPPAK (see [Table 4: Thermal data](#)),  $R_{TH-CH}$  is the case-to-heat sink thermal resistance and the  $R_{TH-HA}$  is the heat sink-to-air thermal resistance.

# 7 Typical performance characteristics

(Refer to the typical application circuit,  $T_J$  from 0 to 85 °C. Typical values are referred to  $T_J = 25$  °C).

Figure 9. Output voltage vs. temperature

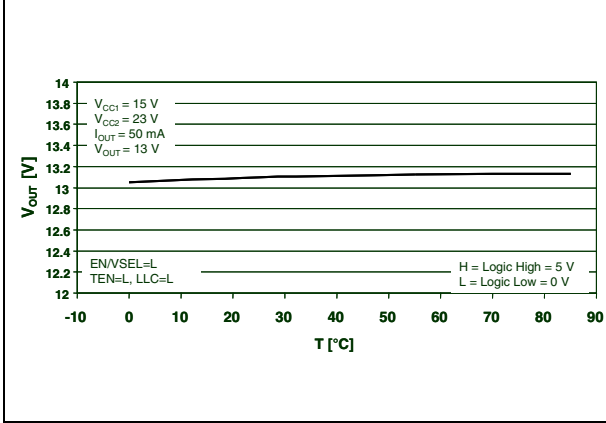

Figure 10. Output voltage vs. temperature

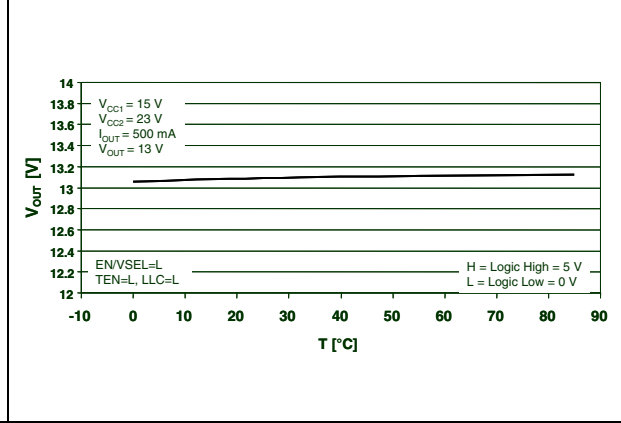

Figure 11. Output voltage vs. temperature

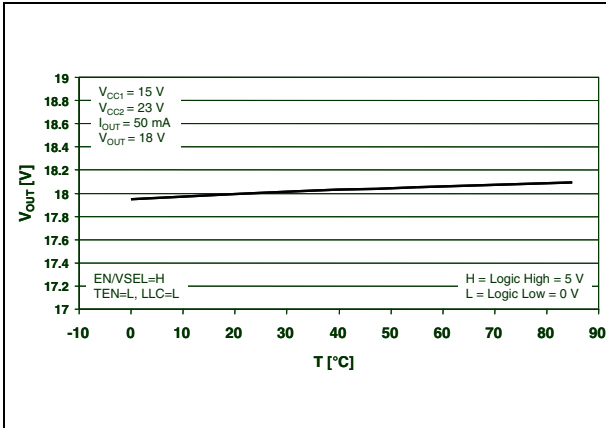

Figure 12. Output voltage vs. temperature

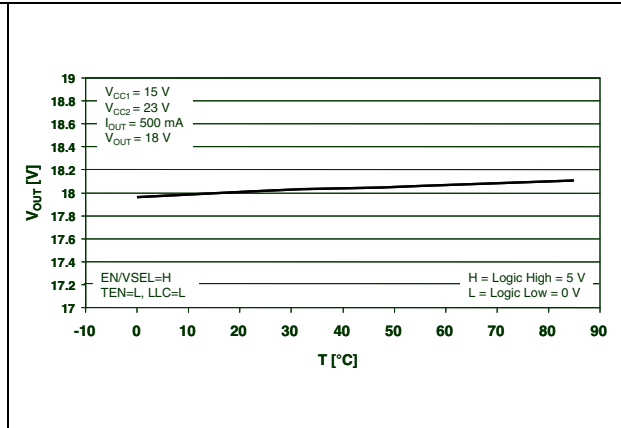

Figure 13. Line regulation vs. temperature

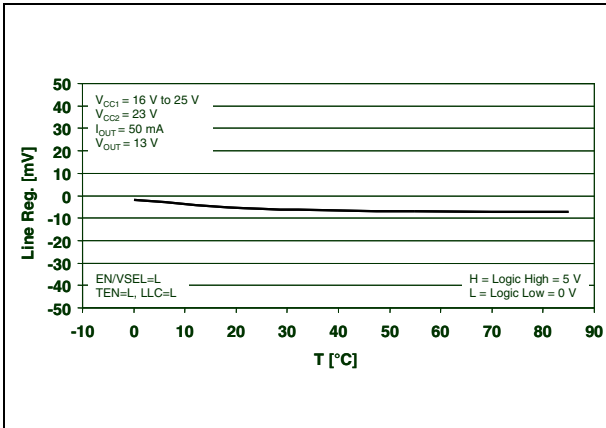

Figure 14. Load regulation vs. temperature

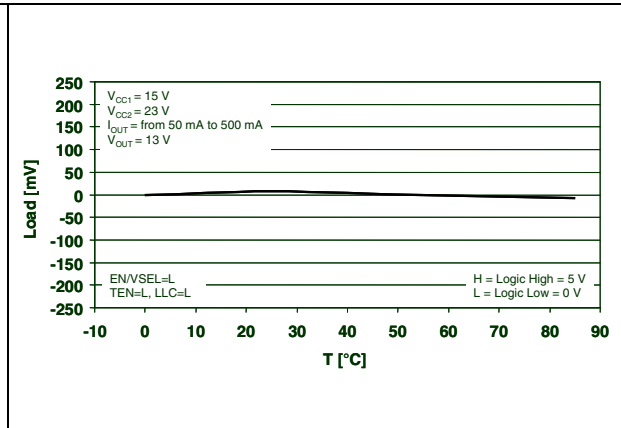

Figure 15. Load regulation vs. temperature

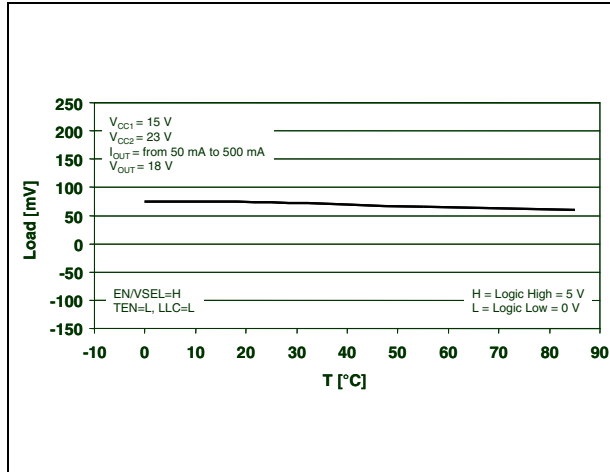

Figure 16. Output current limiting vs. temperature

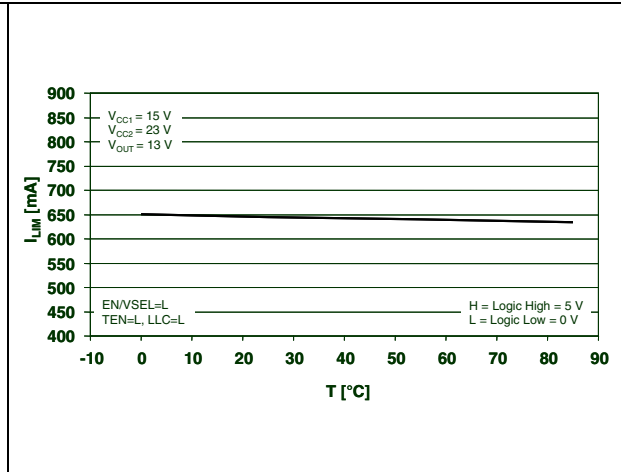

Figure 17. Output current limiting vs. temperature

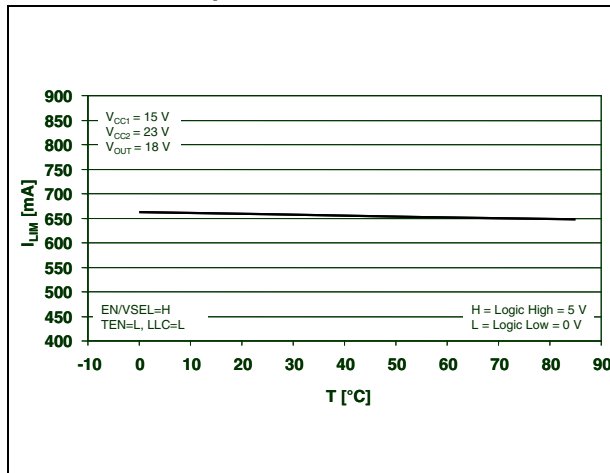

Figure 18. Dynamic overload protection ON time vs. temperature

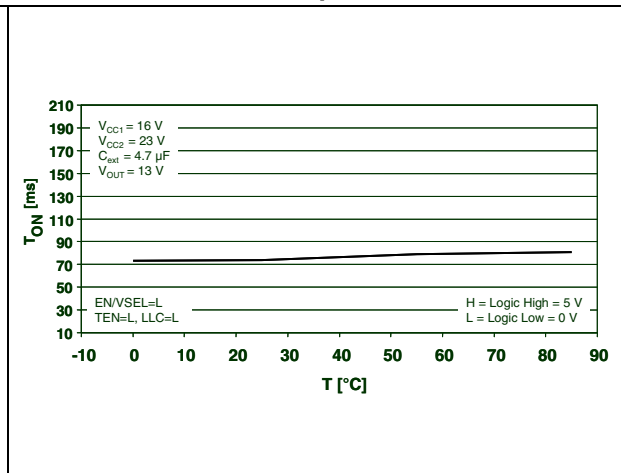

Figure 19. Dynamic overload protection OFF time vs. temperature

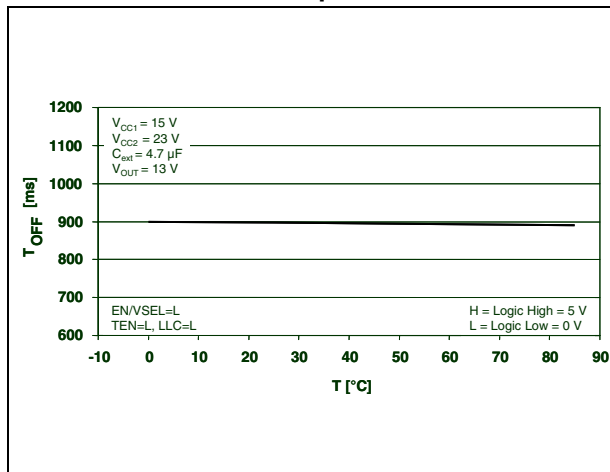

Figure 20. Tone enable

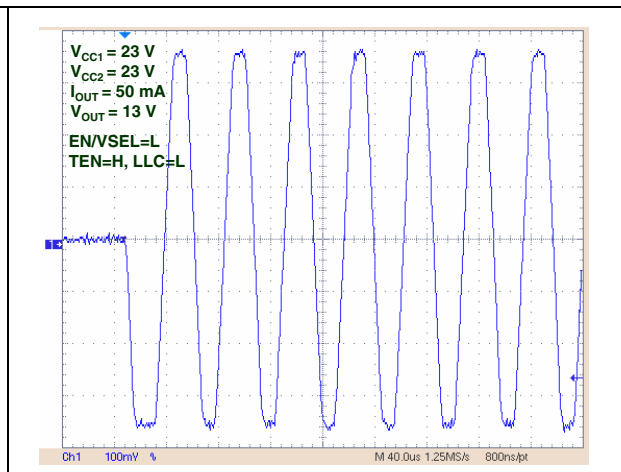

Figure 21. Tone disable

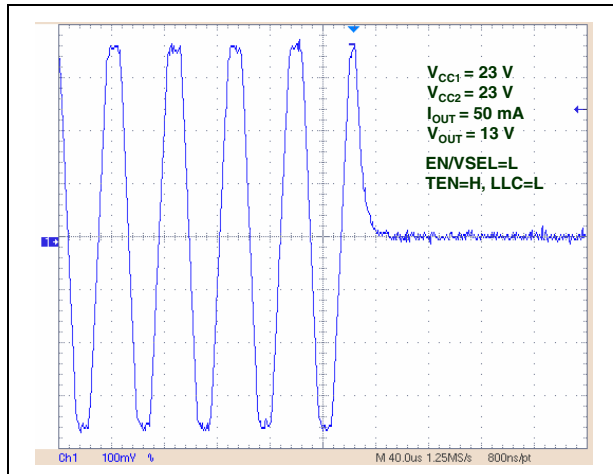

Figure 22. External modulation gain vs. temperature

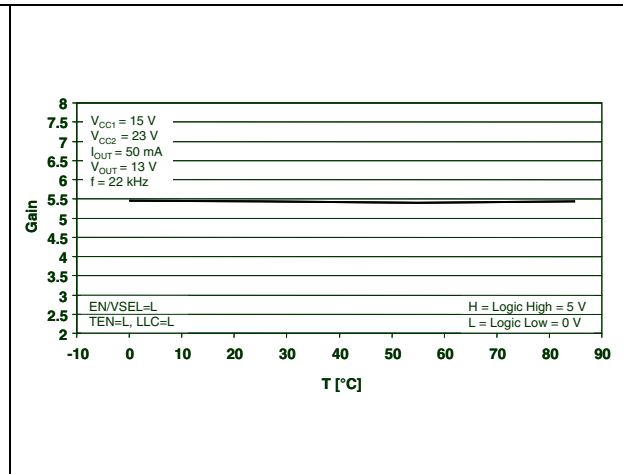

Figure 23. External modulation gain vs. frequency

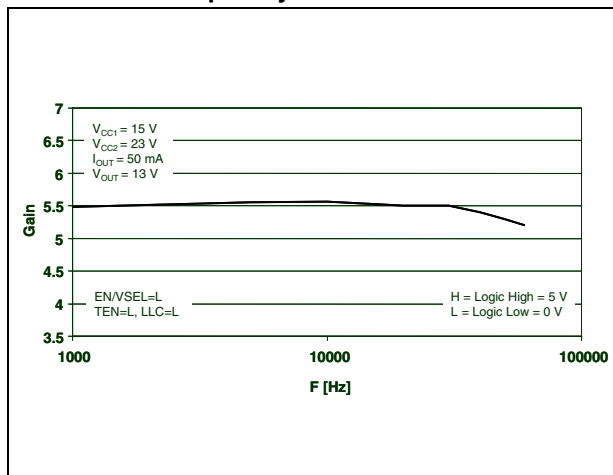

Figure 24.  $T_{ON}$  time vs.  $C_{EXT}$

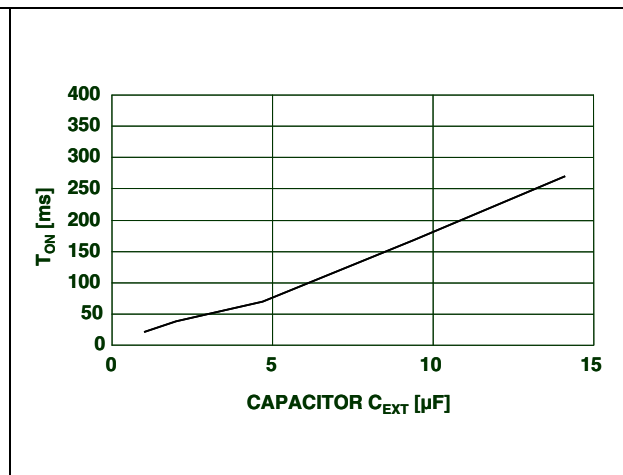
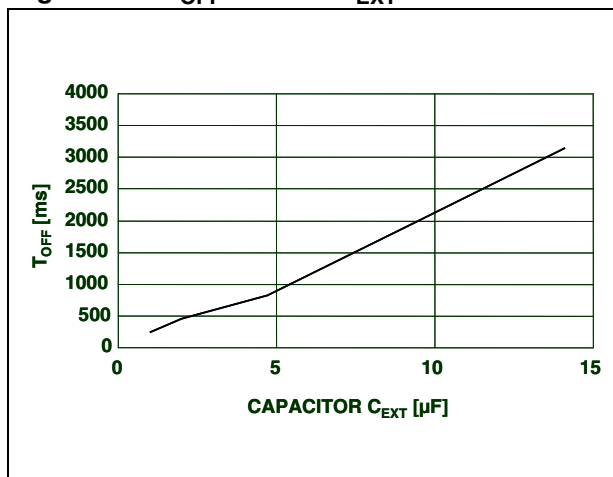

Figure 25.  $T_{OFF}$  time vs.  $C_{EXT}$



## 8 Package mechanical data

In order to meet environmental requirements, ST offers these devices in ECOPACK<sup>®</sup> packages. These packages have a lead-free second level interconnect. The category of second level interconnect is marked on the package and on the inner box label, in compliance with JEDEC Standard JESD97. The maximum ratings related to soldering conditions are also marked on the inner box label. ECOPACK is an ST trademark. ECOPACK specifications are available at: [www.st.com](http://www.st.com).

Figure 26. IPPAK package dimensions

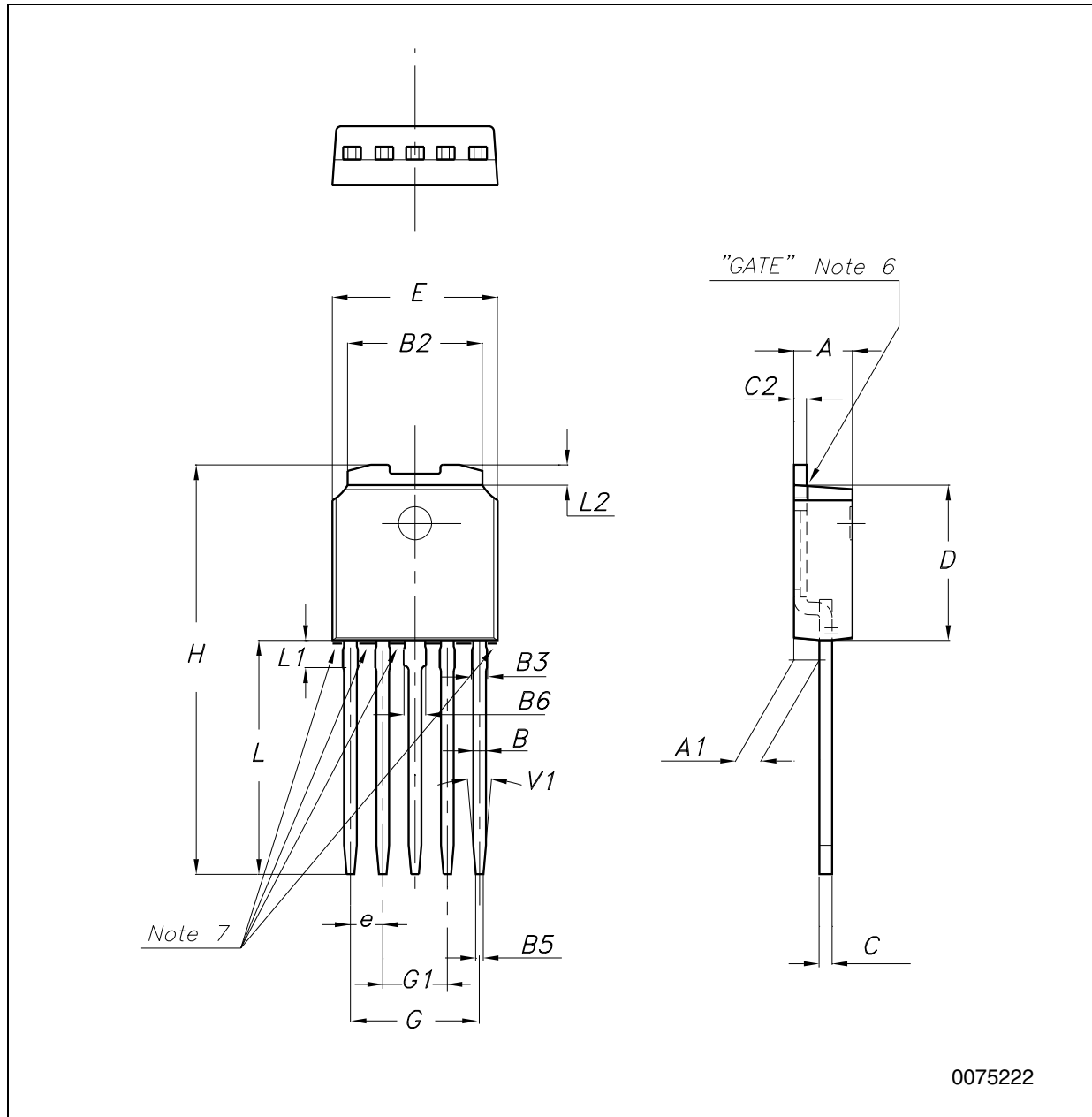



Table 6. IPPAK mechanical data

Dim.	(mm.)		
	Min.	Typ.	Max.
A	2.20		2.40
A1	0.90		1.10
B	0.40		0.60
B2	5.20		5.40
B3			0.70
B5		0.30	
B6			1
C	0.45		0.60
C2	0.48		0.60
D	6		6.20
E	6.40		6.60
e		1.27	
G	4.90		5.25
G1	2.38		2.70
H	15.90		16.30
L	9		9.40
L1	0.80		1.20
L2		0.80	1
V1		10°	

- Note:
- 1 Controlling dimensions: millimeter.
  - 2 Burrs larger than 0.25 mm are not allowed on the upper surface of the dissipater (FRONT) on the lower surface (REAR) the maximum allowed is: 0.05 mm.
  - 3 The side of the dissipater to be connected to the external dissipater must be flat within 30  $\mu$
  - 4 The leads size is comprehensive of the thickness of the leads finishing material.
  - 5 Package outline exclusive of any mold flashes dimensions and metal burrs.
  - 6 Max resin gate protrusion: 0.5 mm.
  - 7 Max resin protrusion: 0.25 mm.
  - 8 The maximum bent leads allowed, in any direction, is: # 2° if the devices are packed in tube.

**DFN8 (5x6 mm) mechanical data**

Dim.	mm.			inch.		
	Min.	Typ.	Max.	Min.	Typ.	Max.
A	0.80	0.90	1.00	0.032	0.035	0.039
A1		0.02	0.05		0.001	0.002
A3		0.20			0.008	
b	0.35	0.40	0.47	0.014	0.016	0.018
D		5.00			0.197	
D2	4.15	4.2	4.25	0.163	0.165	0.167
E		6.00			0.236	
E2	3.55	3.6	3.65	0.140	0.142	0.144
e		1.27			0.049	
F		1.99			0.078	
G		2.20			0.086	
H		0.40			0.015	
I		0.219			0.0086	
L	0.70		0.90	0.028		0.035

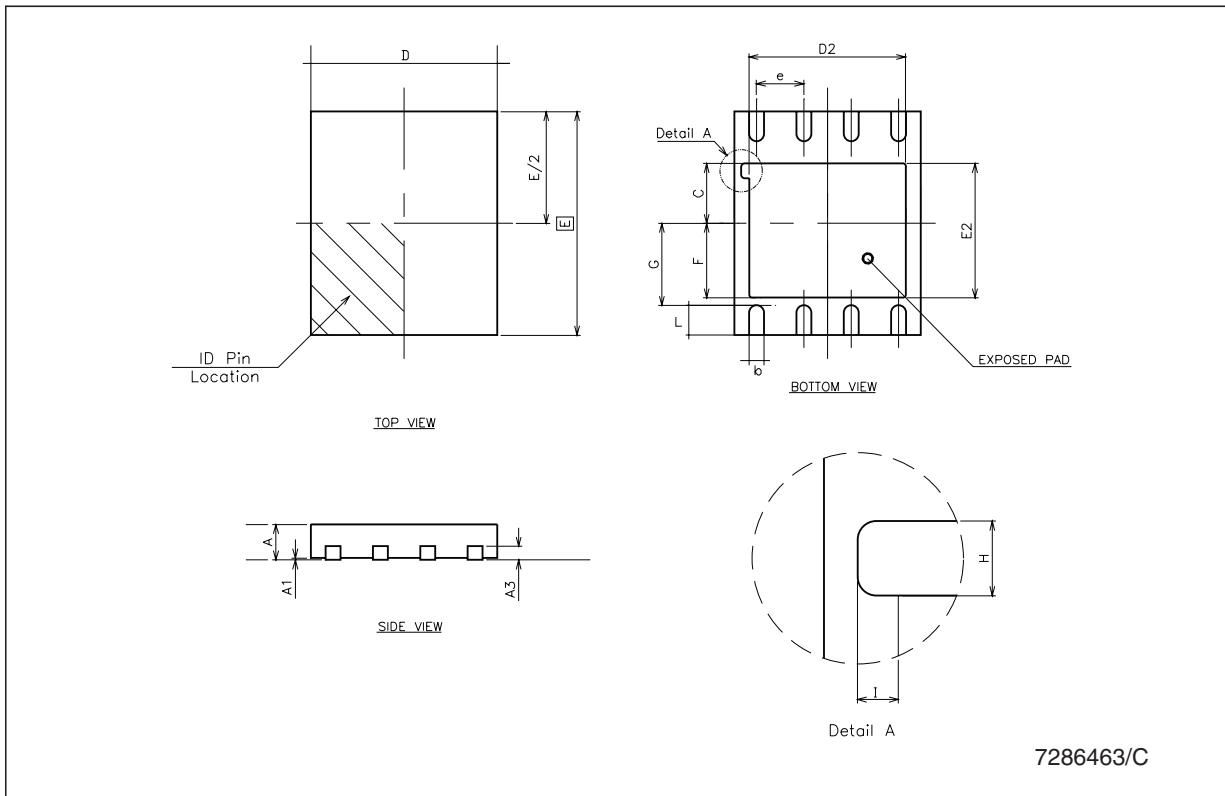

## 9 Ordering information

Table 7. Order codes

Part numbers	Order codes		Packing
	DFN8 (5x6 mm)	IPPAK	
LNBP8L		LNBP8LIT	Tape and reel
LNBP9L		LNBP9LIT	Tape and reel
LNBP10L	LNBP10LPUR		Tape and reel
LNBP11L	LNBP11LPUR		Tape and reel

## 10 Revision history

**Table 8. Document revision history**

Date	Revision	Changes
11-Nov-2008	1	Initial release.

**Please Read Carefully:**

Information in this document is provided solely in connection with ST products. STMicroelectronics NV and its subsidiaries ("ST") reserve the right to make changes, corrections, modifications or improvements, to this document, and the products and services described herein at any time, without notice.

All ST products are sold pursuant to ST's terms and conditions of sale.

Purchasers are solely responsible for the choice, selection and use of the ST products and services described herein, and ST assumes no liability whatsoever relating to the choice, selection or use of the ST products and services described herein.

No license, express or implied, by estoppel or otherwise, to any intellectual property rights is granted under this document. If any part of this document refers to any third party products or services it shall not be deemed a license grant by ST for the use of such third party products or services, or any intellectual property contained therein or considered as a warranty covering the use in any manner whatsoever of such third party products or services or any intellectual property contained therein.

**UNLESS OTHERWISE SET FORTH IN ST'S TERMS AND CONDITIONS OF SALE ST DISCLAIMS ANY EXPRESS OR IMPLIED WARRANTY WITH RESPECT TO THE USE AND/OR SALE OF ST PRODUCTS INCLUDING WITHOUT LIMITATION IMPLIED WARRANTIES OF MERCHANTABILITY, FITNESS FOR A PARTICULAR PURPOSE (AND THEIR EQUIVALENTS UNDER THE LAWS OF ANY JURISDICTION), OR INFRINGEMENT OF ANY PATENT, COPYRIGHT OR OTHER INTELLECTUAL PROPERTY RIGHT.**

**UNLESS EXPRESSLY APPROVED IN WRITING BY AN AUTHORIZED ST REPRESENTATIVE, ST PRODUCTS ARE NOT RECOMMENDED, AUTHORIZED OR WARRANTED FOR USE IN MILITARY, AIR CRAFT, SPACE, LIFE SAVING, OR LIFE SUSTAINING APPLICATIONS, NOR IN PRODUCTS OR SYSTEMS WHERE FAILURE OR MALFUNCTION MAY RESULT IN PERSONAL INJURY, DEATH, OR SEVERE PROPERTY OR ENVIRONMENTAL DAMAGE. ST PRODUCTS WHICH ARE NOT SPECIFIED AS "AUTOMOTIVE GRADE" MAY ONLY BE USED IN AUTOMOTIVE APPLICATIONS AT USER'S OWN RISK.**

Resale of ST products with provisions different from the statements and/or technical features set forth in this document shall immediately void any warranty granted by ST for the ST product or service described herein and shall not create or extend in any manner whatsoever, any liability of ST.

ST and the ST logo are trademarks or registered trademarks of ST in various countries.

Information in this document supersedes and replaces all information previously supplied.

The ST logo is a registered trademark of STMicroelectronics. All other names are the property of their respective owners.

© 2008 STMicroelectronics - All rights reserved

STMicroelectronics group of companies

Australia - Belgium - Brazil - Canada - China - Czech Republic - Finland - France - Germany - Hong Kong - India - Israel - Italy - Japan - Malaysia - Malta - Morocco - Singapore - Spain - Sweden - Switzerland - United Kingdom - United States of America

[www.st.com](http://www.st.com)

## X-ON Electronics

Largest Supplier of Electrical and Electronic Components

*Click to view similar products for [Linear Voltage Regulators](#) category:*

*Click to view products by [STMicroelectronics](#) manufacturer:*

Other Similar products are found below :

[LV56831P-E](#) [LV5684PVD-XH](#) [MCDTSA6-2R](#) [L4953G](#) [L7815ACV-DG](#) [PQ3DZ53U](#) [LV56801P-E](#) [TCR3DF13,LM\(CT](#)  
[TCR3DF39,LM\(CT](#) [TLE42794G](#) [L78L05CZ/1SX](#) [L78LR05DL-MA-E](#) [L78MR05-E](#) [033150D](#) [033151B](#) [090756R](#) [636416C](#)  
[NCV78M15BDTG](#) [702482B](#) [714954EB](#) [TLE42794GM](#) [TLE42994GM](#) [ZMR500QFTA](#) [BA033LBSG2-TR](#) [NCV78M05ABDTRKG](#)  
[NCV78M08BDTRKG](#) [NCP7808TG](#) [NCV571SN12T1G](#) [LV5680P-E](#) [CAJ24C256YI-GT3](#) [L78M15CV-DG](#) [L9474N](#)  
[TLS202B1MBV33HTSA1](#) [L79M05T-E](#) [NCP571SN09T1G](#) [MAX15006AASA/V+](#) [MIC5283-5.0YML-T5](#) [L4969URTR-E](#) [L78LR05D-MA-E](#)  
[NCV7808BDTRKG](#) [L9466N](#) [NCP7805ETG](#) [SC7812CTG](#) [NCV7809BTG](#) [NCV571SN09T1G](#) [NCV317MBTG](#) [MC78M15CDTT5G](#)  
[MC78M12CDTT5G](#) [L9468N](#) [LT1054IS8#TRPBF](#)