

MEMS pressure sensor: 300-1200 hPa absolute digital output barometer with potted gel package

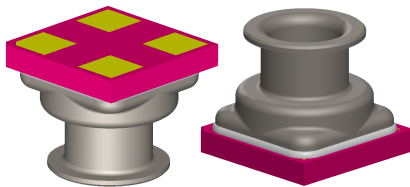

CCLGA 4L
3.3 x 3.3 x (max) x 2.9 mm

Features

- Pressure sensor with potted gel package
- 300 to 1200 hPa absolute pressure range
- Current consumption down to 4 μ A
- High overpressure capability: 20x full scale
- Embedded temperature compensation
- 24-bit pressure data output
- 16-bit temperature data output
- ODR from 1 Hz to 75 Hz
- I²C interfaces
- Supply voltage: 1.7 to 3.6 V
- ECOPACK lead-free compliant

Applications

- [Wearable devices](#)
- Altimeters and barometers for portable devices
- GPS applications
- Weather station equipment
- e-cigarettes

Product status link		
LPS33K		
Product summary		
Order code	LPS33KTR	LPS33K
Temp. range [°C]	-40 to +85	
Package	CCLGA-4L 3.3 x 3.3 x (max) 2.9 mm	
Packing	Tape and reel	Tray

Description

The LPS33K is an ultra-compact piezoresistive pressure sensor which functions as a digital output barometer. The device comprises a sensing element and an IC interface which communicates through I²C from the sensing element to the application.

The sensing element, which detects absolute pressure, consists of a suspended membrane manufactured using a dedicated process developed by ST.

The LPS33K is available in a ceramic LGA package with metal lid. It is guaranteed to operate over a temperature range extending from -40 °C to +85 °C. The package is holed to allow external pressure to reach the sensing element. Gel inside the IC protects the electrical components from harsh environmental conditions.

1 Block diagram and pin description

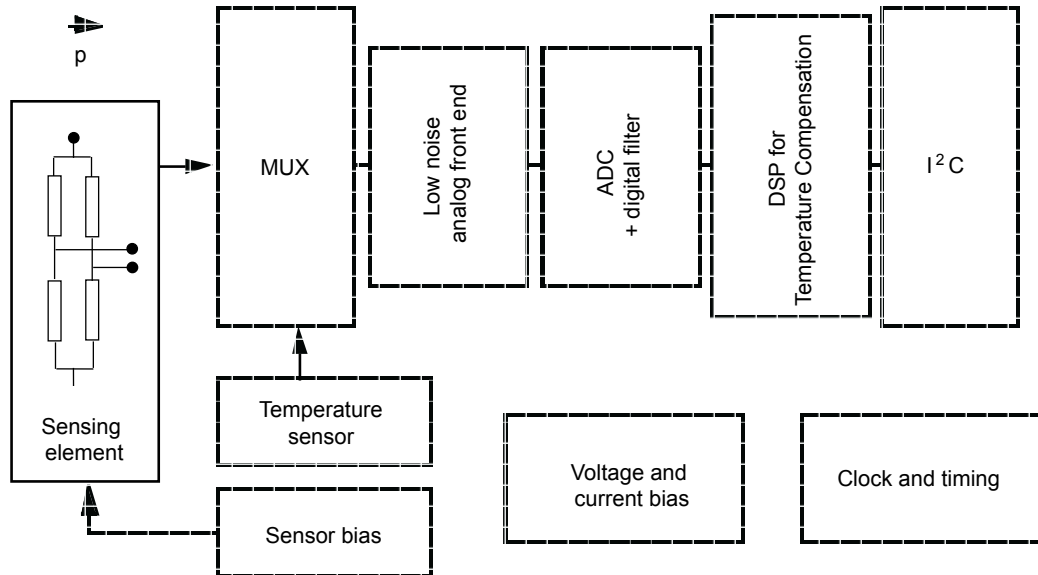
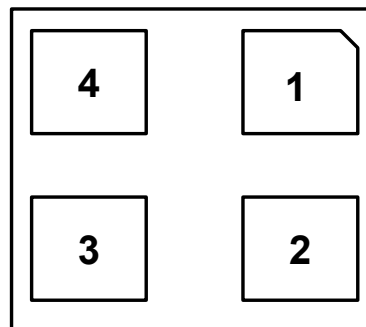
Figure 1. Block diagram

Figure 2. Pin connections (bottom view)

Table 1. Pin description

Pin number	Pin name	Function
1	GND	0 V supply
2	VDD	Power supply
3	SCL	I²C serial clock
4	SDA	I²C serial data

2 Mechanical and electrical specifications

2.1 Mechanical characteristics

VDD = 1.8 V, T = 25 °C, unless otherwise noted.

Table 2. Pressure and temperature sensor characteristics

Symbol	Parameter	Test condition	Min.	Typ. ⁽¹⁾	Max.	Unit
Pressure sensor characteristics						
P _{T_{op}}	Operating temperature range		-40		+85	°C
P _{T_{full}}	Full accuracy temperature range		0		+65	°C
P _{Op}	Operating pressure range		300		1200	hPa
P _{bits}	Pressure output data			24		bits
P _{sens}	Pressure sensitivity			4096		LSB/hPa
P _{AccRel}	Relative accuracy over pressure ⁽²⁾	P = 800 - 1100 hPa, T = 25 °C	-0.5		+0.5	hPa
P _{AccT}	Absolute accuracy over temperature	P _{Op} , T = 0 ~ 65 °C Before One-Point Calibration		±3		hPa
P _{noise}	RMS pressure sensing noise ⁽³⁾	With embedded filtering (ODR/20 in low-current mode)		0.016		hPa RMS
		With embedded filtering (ODR/20 in low-noise mode)		0.008		
ODR _{Pres}	Pressure output data rate			1		Hz
				10		
				25		
				50		
				75		
P _{longterm}	Pressure accuracy, long-term stability			±1		hPa/year
Temperature sensor characteristics						
T _{Op}	Operating temperature range		-40		+85	°C
T _{sens}	Temperature sensitivity			100		LSB/°C
ODR _T	Temperature output data rate			1		Hz
				10		
				25		
				50		
				75		

1. Typical specifications are not guaranteed.

2. No production limit & based on results of characterization.

3. Pressure noise RMS evaluated in a controlled environment, based on the average standard deviation of 32 measurements at highest ODR.

2.2 Electrical characteristics

VDD = 1.8 V, T = 25 °C, unless otherwise noted.

Table 3. Electrical characteristics

Symbol	Parameter	Test condition	Min.	Typ. ⁽¹⁾	Max.	Unit
VDD	Supply voltage		1.7		3.6	V
Idd	Supply current	@ ODR 1 Hz LC_EN bit = 0 (low-noise mode)		15		µA
		@ ODR 1 Hz LC_EN bit = 1 (low-current mode)		4		
IddPdn	Supply current in power-down mode			1		µA

1. Typical specifications are not guaranteed.

Table 4. DC characteristics

Symbol	Parameter	Condition	Min.	Typ.	Max.	Unit
DC input characteristics						
Vil	Low-level input voltage (Schmitt buffer)				0.2 * Vdd	V
Vih	High-level input voltage (Schmitt buffer)		0.8 * Vdd			V
DC output characteristics						
Vol	Low-level output voltage				0.2	V
Voh	High-level output voltage		Vdd - 0.2			V

2.3 Communication interface characteristics

2.3.1 I²C - inter-IC control interface

Subject to general operating conditions for V_{DD} and T_{OP}.

Table 5. I²C slave timing values

Symbol	Parameter	I ² C standard mode ⁽¹⁾		I ² C fast mode ⁽¹⁾		Unit
		Min.	Max	Min.	Max.	
f _(SCL)	SCL clock frequency	0	100	0	400	kHz
t _{w(SCLL)}	SCL clock low time	4.7		1.3		μs
t _{w(SCLH)}	SCL clock high time	4.0		0.6		
t _{su(SDA)}	SDA setup time	250		100		ns
t _{h(SDA)}	SDA data hold time	0	3.45	0	0.9	μs
t _{h(ST)}	START condition hold time	4		0.6		μs
t _{su(SR)}	Repeated START condition setup time	4.7		0.6		
t _{su(SP)}	STOP condition setup time	4		0.6		
t _{w(SP:SR)}	Bus free time between STOP and START condition	4.7		1.3		

1. Data based on standard I²C protocol requirement, not tested in production.

Figure 3. I²C slave timing diagram

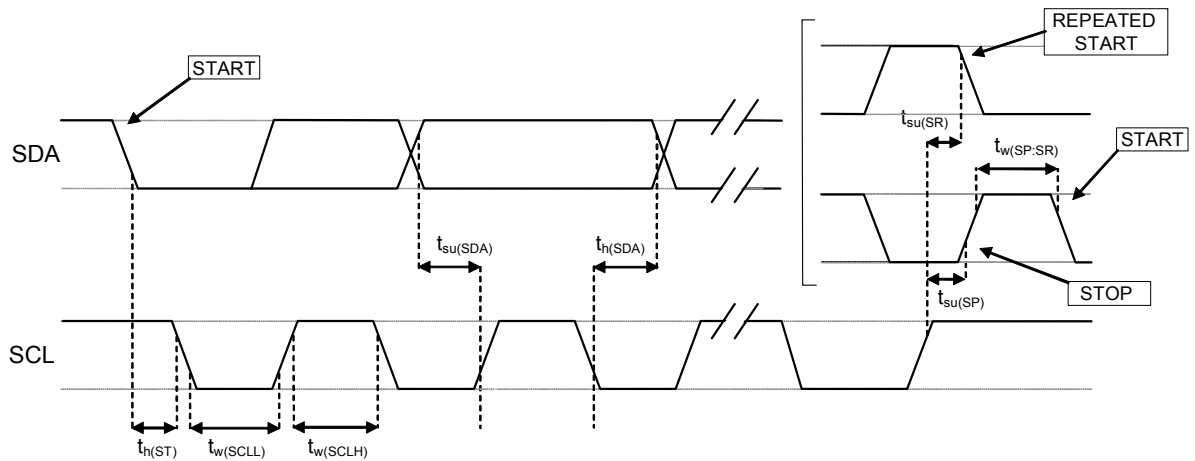

Note: Measurement points are done at 0.2·V_{DD} and 0.8·V_{DD} for both ports.

2.4 Absolute maximum ratings

Stress above those listed as “Absolute maximum ratings” may cause permanent damage to the device. This is a stress rating only and functional operation of the device under these conditions is not implied. Exposure to maximum rating conditions for extended periods may affect device reliability.

Table 6. Absolute maximum ratings

Symbol	Ratings	Maximum value	Unit
Vdd	Supply voltage	-0.3 to 4.8	V
Vin	Input voltage on any control pin	-0.3 to Vdd_IO +0.3	V
T _{STG}	Storage temperature range	-40 to +125	°C
ESD	Electrostatic discharge protection	2 (HBM)	kV

Note: Supply voltage on any pin should never exceed 4.8 V.



This device is sensitive to mechanical shock, improper handling can cause permanent damage to the part.



This device is sensitive to electrostatic discharge (ESD), improper handling can cause permanent damage to the part.

3 Functionality

The LPS33K is a high-resolution, digital output pressure sensor packaged in a CCLGA package with metal lid. The complete device includes a sensing element based on a piezoresistive Wheatstone bridge approach, and an IC interface which communicates a digital signal from the sensing element to the application.

3.1 Sensing element

An ST proprietary process is used to obtain a silicon membrane for MEMS pressure sensors. When pressure is applied, the membrane deflection induces an imbalance in the Wheatstone bridge piezoresistances whose output signal is converted by the IC interface.

3.2 IC interface

The complete measurement chain is composed of a low-noise amplifier which converts the resistance unbalance of the MEMS sensors (pressure and temperature) into an analog voltage using an analog-to-digital converter.

The pressure and temperature data may be accessed through an I²C interface thus making the device particularly suitable for direct interfacing with a microcontroller.

The LPS33K features a data-ready signal which indicates when a new set of measured pressure and temperature data are available, thus simplifying data synchronization in the digital system that uses the device.

3.3 Factory calibration

The trimming values are stored inside the device in a non-volatile structure. When the device is turned on, the trimming parameters are downloaded into the registers to be employed during the normal operation which allows the device to be used without requiring any further calibration.

3.4 Device structure

The LPS33K has a unique cylindrical package solution with a full metal lid assembled on ceramic substrate and this cylindrical package provides an easy assembly with O-rings in the end user's application.

Figure 4. LPS33K internal structure

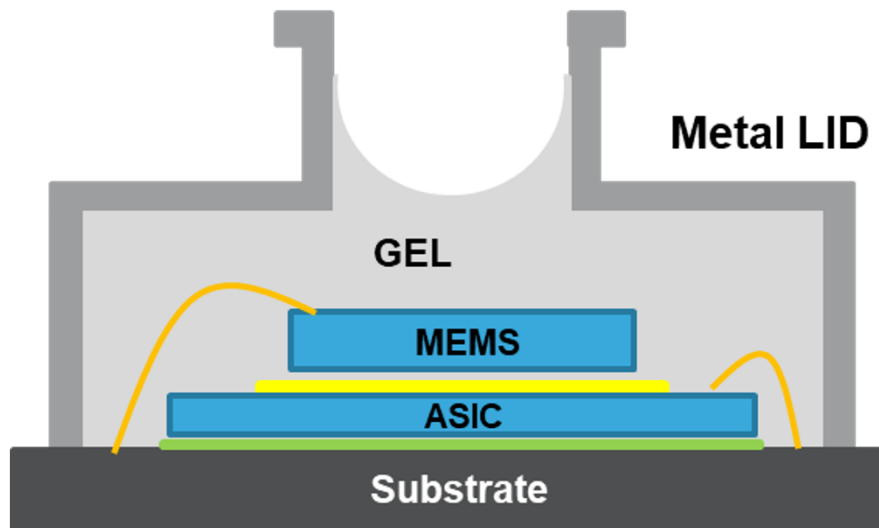

This structure (Figure 4) is to show the inner structure of the LPS33K with a metal lid and potting gel. This structure is designed for and proven to protect electronic components from long-term exposure to harsh environments such as water mixed with chlorine, bromine, commercial washing detergent and fuels, solvents and chemicals. It also provides excellent low-stress encapsulation performance for sensitive electronic components from severe environmental conditions such as high temperature and humidity, refer to the properties of the gel which are given in the following table.

Table 7. Potting gel properties

Properties	Potting gel
Permeability g/m ² ·24 hr	7
Hardness (penetration) based on ASTM D1403	70
Ultra-low Young's modulus	Less than 0.01 GPa
TCE (Thermal Coefficient of Expansion)	300 ppm/°C

3.5 Interpreting pressure readings

The pressure data are stored 3 registers: `PRESS_OUT_H` (2Ah), `PRESS_OUT_L` (29h), and `PRESS_OUT_XL` (28h). The value is expressed as 2's complement.

To obtain the pressure in hPa, take the two's complement of the complete word and then divide by 4096 LSB/hPa.

Figure 5. Pressure readings



Equation 1

$$\begin{aligned} \text{Pressure Value (LSB)} &= \text{PRESS_OUT_H (2Ah) \& \text{PRESS_OUT_L (29h) \& \text{PRESS_OUT_XL (28h)} \\ &= 3FF58Dh = 4191629 \text{ LSB (decimal signed)} \end{aligned}$$

Equation 2

$$\text{Pressure (hPa)} = \frac{\text{Pressure Value (LSB)}}{\text{Scaling Factor}} = \frac{4191629 \text{ LSB}}{4096 \text{ LSB/hPa}} = 1023.3\text{hPa}$$

4 Application hints

Figure 6. LPS33K electrical connections (bottom view)

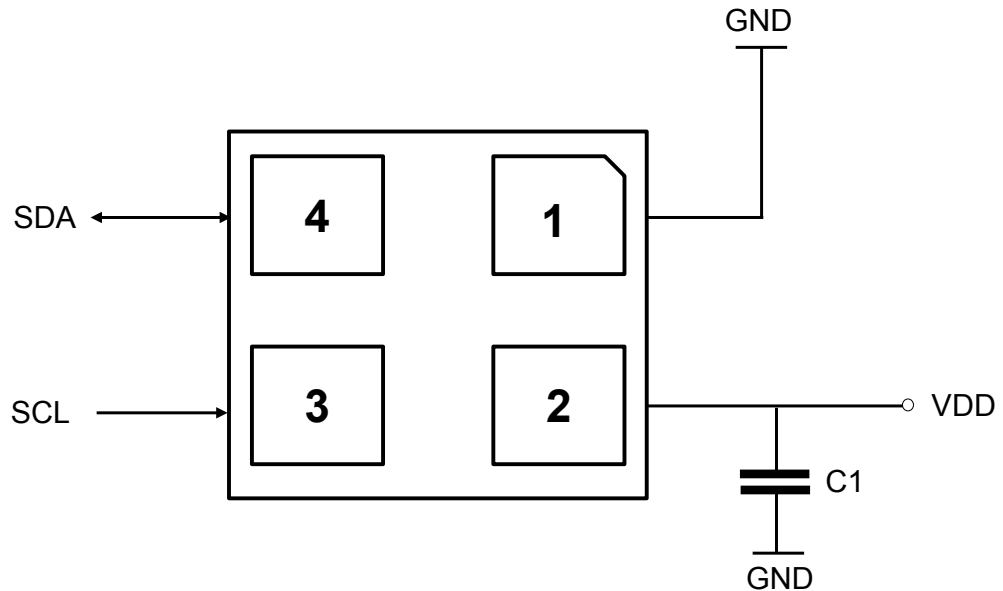

The device power supply must be provided through the VDD line; a power supply decoupling capacitor C1 (100 nF) must be placed as near as possible to the supply pads of the device. Depending on the application, an additional capacitor of 4.7 μ F could be placed on the VDD line.

The functionality of the device and the measured data outputs are selectable and accessible through the I²C interface.

All the voltage and ground supplies must be present at the same time to have proper behavior of the IC (refer to Figure 6).

Figure 7. LPS33K power-off sequence

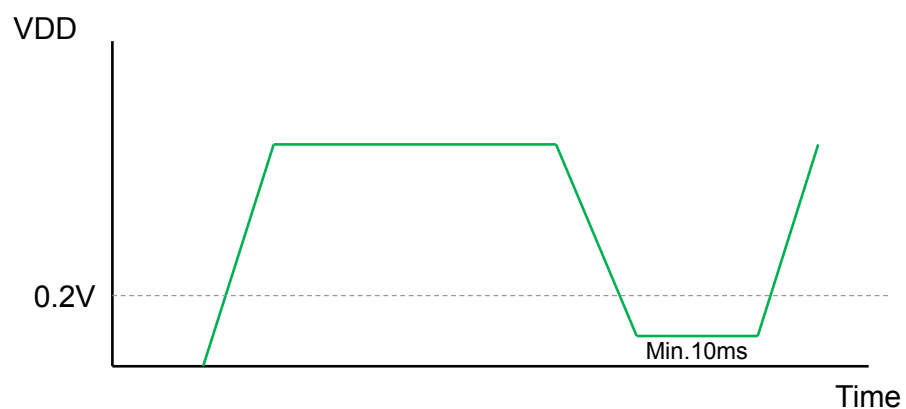

- VDD Rising / Falling time : 10 μ s ~ 100 ms
- VDD must be lower than 0.2 V for at least 10 ms during power-off sequence for correct POR

4.1 Soldering information

The CCLGA package is compliant with the [ECOPACK](#) standard and it is qualified for soldering heat resistance according to JEDEC J-STD-020.

5 Digital interfaces

5.1 IC serial interface

The registers embedded in the LPS33K may be accessed through the I²C interface.

Table 8. Serial interface pin description

Pin name	Pin description
SCL	I ² C serial clock (SCL)
SDA	I ² C serial data (SDA)

5.2 I²C serial interface

The LPS33K I²C is a bus slave. The I²C is employed to write data into registers whose content can also be read back.

The relevant I²C terminology is given in the following table.

Table 9. I²C terminology

Term	Description
Transmitter	The device which sends data to the bus
Receiver	The device which receives data from the bus
Master	The device which initiates a transfer, generates clock signals and terminates a transfer
Slave	The device addressed by the master

There are two signals associated with the I²C bus: the serial clock line (SCL) and the serial data line (SDA). The latter is a bidirectional line used for sending and receiving the data to/from the interface. Both lines have to be connected to VDD through pull-up resistors.

The I²C interface is compliant with fast mode (400 kHz) I²C standards as well as with the normal mode.

5.2.1 I²C operation

The transaction on the bus is started through a START (ST) signal. A start condition is defined as a HIGH-to-LOW transition on the data line while the SCL line is held HIGH. After this has been transmitted by the master, the bus is considered busy. The next data byte transmitted after the start condition contains the address of the slave in the first 7 bits and the eighth bit tells whether the master is receiving data from the slave or transmitting data to the slave. When an address is sent, each device in the system compares the first seven bits after a start condition with its address. If they match, the device considers itself addressed by the master.

The slave address (SAD) associated to the LPS33K is 1011101b.

Data transfer with acknowledge is mandatory. The transmitter must release the SDA line during the acknowledge pulse. The receiver must then pull the data line LOW so that it remains stable low during the HIGH period of the acknowledge clock pulse. A receiver which has been addressed is obliged to generate an acknowledge after each byte of data received.

The I²C embedded inside the ASIC behaves like a slave device and the following protocol must be adhered to. After the start condition (ST) a slave address is sent, once a slave acknowledge has been returned (SAK), an 8-bit sub-address will be transmitted (SUB): the 7 LSB represent the actual register address while the MSB has no meaning. The IF_ADD_INC bit in CTRL_REG2 (11h) enables sub-address auto increment (IF_ADD_INC is '1' by default), so if IF_ADD_INC = '1' the SUB (sub-address) will be automatically increased to allow multiple data read/write.

The slave address is completed with a Read/Write bit. If the bit is '1' (Read), a repeated START (SR) condition must be issued after the two sub-address bytes; if the bit is '0' (Write) the master will transmit to the slave with direction unchanged. The following table explains how the SAD+read/write bit pattern is composed, listing all the possible configurations.

Table 10. SAD+Read/Write patterns

Command	SAD[6:0]	R/W	SAD+R/W
Read	1011101	1	10111011 (BBh)
Write	1011101	0	10111010 (BAh)

Table 11. Transfer when master is writing one byte to slave

Master	ST	SAD + W		SUB		DATA		SP
Slave			SAK		SAK		SAK	

Table 12. Transfer when master is writing multiple bytes to slave

Master	ST	SAD + W		SUB		DATA		DATA		SP
Slave			SAK		SAK		SAK		SAK	

Table 13. Transfer when master is receiving (reading) one byte of data from slave

Master	ST	SAD + W		SUB		SR	SAD + R			NMAK	SP
Slave			SAK		SAK			SAK	DATA		

Table 14. Transfer when master is receiving (reading) multiple bytes of data from slave

Master	ST	SAD+W		SUB		SR	SAD+R			MAK		MAK		NMAK	SP
Slave			SAK		SAK			SAK	DATA		DATA		DATA		

Data are transmitted in byte format (DATA). Each data transfer contains 8 bits. The number of bytes transferred per transfer is unlimited. Data is transferred with the most significant bit (MSb) first. If a slave receiver does not acknowledge the slave address (i.e. it is not able to receive because it is performing some real-time function) the data line must be kept HIGH by the slave. The master can then abort the transfer. A LOW-to-HIGH transition on the SDA line while the SCL line is HIGH is defined as a STOP condition. Each data transfer must be terminated by the generation of a STOP (SP) condition.

In the presented communication format MAK is master acknowledge and NMAK is no master acknowledge.

6 Register map

The following table provides a quick overview of the 8-bit registers embedded in the device.

Table 15. Registers address map

Name	Type	Register Address	Default	Function and comment
		Hex	Binary	
Reserved	-	00-0E	-	Reserved
WHO_AM_I	R	0F	10110001	Who am I
CTRL_REG1	R/W	10	00000000	Control registers
CTRL_REG2	R/W	11	00010000	
CTRL_REG3	R/W	12	00000000	
Reserved	-	13-17	-	Reserved
RPDS_L	R/W	18	00000000	Pressure offset registers
RPDS_H	R/W	19	00000000	
RES_CONF	R/W	1A	00000000	Resolution register
Reserved	-	1B-26	-	Reserved
STATUS	R	27	output	Status register
PRESS_OUT_XL	R	28	output	Pressure output registers
PRESS_OUT_L	R	29	output	
PRESS_OUT_H	R	2A	output	
TEMP_OUT_L	R	2B	output	Temperature output registers
TEMP_OUT_H	R	2C	output	
Reserved	-	2D-32	-	Reserved
LPFP_RES	R	33	output	Filter reset register

Registers marked as Reserved must not be changed. Writing to those registers may cause permanent damage to the device.

To guarantee the proper behavior of the device, all register addresses not listed in the above table must not be accessed and the content stored in those registers must not be changed.

The content of the registers that are loaded at boot should not be changed. They contain the factory calibration values. Their content is automatically restored when the device is powered up.

7 Register description

The device contains a set of registers which are used to control its behavior and to retrieve pressure and temperature data. The register address, made up of 7 bits, is used to identify them and to read/write the data through the serial interface.

7.1 WHO_AM_I (0Fh)

Device Who am I

7	6	5	4	3	2	1	0
1	0	1	1	0	0	0	1

7.2 CTRL_REG1 (10h)

Control register 1

7	6	5	4	3	2	1	0
0 ⁽¹⁾	ODR2	ODR1	ODR0	EN_LPFP	LPFP_CFG	BDU	0 ⁽¹⁾

1. This bit must be set to '0' for proper operation of the device.

ODR[2:0]	Output data rate selection. Default value: 000 Refer to Table 16 .
EN_LPFP	Enable low-pass filter on pressure data. Default value: 0 (0: low-pass filter disabled; 1: low-pass filter enabled)
LPFP_CFG	Low-pass configuration register. Default value: 0 Refer to Table 17 .
BDU ⁽¹⁾	Block data update. Default value: 0 (0: continuous update; 1: output registers not updated until MSB and LSB have been read)

1. To guarantee the correct behavior of the BDU feature, [PRESS_OUT_H \(2Ah\)](#) must be the last address read.

Table 16. Output data rate bit configurations

ODR2	ODR1	ODR0	Pressure (Hz)	Temperature (Hz)
0	0	0	Power down / one-shot mode enabled	
0	0	1	1 Hz	1 Hz
0	1	0	10 Hz	10 Hz
0	1	1	25 Hz	25 Hz
1	0	0	50 Hz	50 Hz
1	0	1	75 Hz	75 Hz

When the ODR bits are set to '000' the device is in **Power-down mode**. When the device is in power-down mode, almost all internal blocks of the device are switched off to minimize power consumption. The I²C interface is still active to allow communication with the device. The content of the configuration registers is preserved and output data registers are not updated, therefore keeping the last data sampled in memory before going into power-down mode.

If the ONE_SHOT bit in CTRL_REG2 (11h) is set to '1', **One-shot mode** is triggered and a new acquisition starts when it is required. Enabling this mode is possible only if the device was previously in power-down mode (ODR bits set to '000'). Once the acquisition is completed and the output registers updated, the device automatically enters in power-down mode. The ONE_SHOT bit self-clears itself.

When the ODR bits are set to a value different than '000', the device is in **Continuous mode** and automatically acquires a set of data (pressure and temperature) at the frequency selected through the ODR[2:0] bits.

Once the additional low-pass filter has been enabled through the EN_LPFP bit, it is possible to configure the device bandwidth acting on the LPFP_CFG bit. Refer to the following table for low-pass filter configurations.

Table 17. Low-pass filter configurations

EN_LPFP	LPFP_CFG	Additional low-pass filter status	Device bandwidth
0	x	Disabled	ODR/2
1	0	Enabled	ODR/9
1	1	Enabled	ODR/20

The **BDU** bit is used to inhibit the update of the output registers between the reading of the upper and lower register parts. In default mode (BDU = '0'), the lower and upper register parts are updated continuously. When the BDU is activated (BDU = '1'), the content of the output registers is not updated until [PRESS_OUT_H \(2Ah\)](#) is read, in order to avoid reading values related to different samples.

7.3 CTRL_REG2 (11h)

Control register 2

7	6	5	4	3	2	1	0
BOOT	0 ⁽¹⁾	0 ⁽¹⁾	IF_ADD_INC	0 ⁽¹⁾	SWRESET	0 ⁽¹⁾	ONE_SHOT

1. This bit must be set to '0' for proper operation of the device.

BOOT	Reboot memory content. Default value: 0 (0: normal mode; 1: reboot memory content). The bit is self-cleared when the BOOT is completed.
IF_ADD_INC	Register address automatically incremented during a multiple byte access with a serial interface (I ² C). Default value: 1 (0: disable; 1 enable)
SWRESET	Software reset. Default value: 0 (0: normal mode; 1: software reset). The bit is self-cleared when the reset is completed.
ONE_SHOT	One-shot enable. Default value: 0 (0: idle mode; 1: a new dataset is acquired)

The **BOOT** bit is used to refresh the content of the internal registers stored in the Flash memory block. At device power-up the content of the Flash memory block is transferred to the internal registers related to the trimming functions to allow correct behavior of the device itself. If for any reason the content of the trimming registers is modified, it is sufficient to use this bit to restore the correct values. When the BOOT bit is set to '1', the content of the internal Flash is copied inside the corresponding internal registers and is used to calibrate the device. These values are factory trimmed and they are different for every device. They allow correct behavior of the device and normally they should not be changed. At the end of the boot process the BOOT bit is set again to '0' by hardware. The BOOT bit takes effect after one ODR clock cycle.

The **IF_ADD_INC** bit is enabled to increment the register address automatically during a multiple byte access with I²C. In order to read the data properly on multiple byte and single byte access, the recommended configuration for the LPS33K is the following.

- For multiple byte access, synchronous data reading is only allowed with IF_ADD_INC = 1 and BDU = 0;
- For single byte access, either synchronous or asynchronous can be used with IF_ADD_INC = 0, but BDU has to be set to "1" for asynchronous data reading.

SWRESET is the software reset bit. The following device registers (**CTRL_REG1 (10h)**, **CTRL_REG2 (11h)**) are reset to the default value if the SWRESET bit is set to '1'. The SWRESET bit returns back to '0' by hardware.

The **ONE_SHOT** bit is used to start a new conversion when the ODR[2:0] bits in **CTRL_REG1 (10h)** are set to '000'. Writing a '1' in ONE_SHOT triggers a single measurement of pressure and temperature. Once the measurement is done, the ONE_SHOT bit will self-clear, the new data are available in the output registers, and the **STATUS (27h)** bits are updated.

7.4 RPDS_L (18h)

Pressure offset (LSB data)

7	6	5	4	3	2	1	0
RPDS7	RPDS6	RPDS5	RPDS4	RPDS3	RPDS2	RPDS1	RPDS0

RPDS[7:0]	This register contains the low part of the pressure offset value.
-----------	---

If, after the soldering of the component, a residual offset is still present, it can be removed with a one-point calibration.

After soldering, the measured offset can be stored in the [RPDS_H \(19h\)](#) and [RPDS_L \(18h\)](#) registers and automatically subtracted from the pressure output registers: the output pressure register [PRESS_OUT \(28h, 29h and 2Ah\)](#) is provided as the difference between the measured pressure and the content of the register $256 \times \text{RPDS}$ (18h, 19h).

7.5 RPDS_H (19h)

Pressure offset (MSB data)

7	6	5	4	3	2	1	0
RPDS15	RPDS14	RPDS13	RPDS12	RPDS11	RPDS10	RPDS9	RPDS8

RPDS[15:8]	This register contains the high part of the pressure offset value. Refer to RPDS_L (18h) .
------------	--

7.6 RES_CONF (1Ah)

Low-power mode configuration

7	6	5	4	3	2	1	0
0 ⁽¹⁾	0 ⁽¹⁾	0 ⁽¹⁾	0 ⁽¹⁾	0 ⁽¹⁾	0 ⁽¹⁾	reserved ⁽²⁾	LC_EN

1. This bit must be set to '0' for proper operation of the device.
2. The content of this bit must not be modified for proper operation of the device.

LC_EN ⁽¹⁾	Low-current mode enable. Default: 0 (0: normal mode (low-noise mode); 1: low-current mode).
----------------------	--

1. The [LC_EN](#) bit must be changed only with the device in power down and not during operation. Once the [LC_EN](#) bit is configured, it affects both One-shot mode and Continuous mode.

7.7 STATUS (27h)

Status register

7	6	5	4	3	2	1	0
-	-	T_OR	P_OR	-	-	T_DA	P_DA

T_OR	Temperature data overrun. (0: no overrun has occurred; 1: new data for temperature has overwritten the previous data)
P_OR	Pressure data overrun. (0: no overrun has occurred; 1: new data for pressure has overwritten the previous data)
T_DA	Temperature data available. (0: new data for temperature is not yet available; 1: new data for temperature is available)
P_DA	Pressure data available. (0: new data for pressure is not yet available; 1: new data for pressure is available)

This register is updated every ODR cycle.

7.8 PRESS_OUT_XL (28h)

Pressure output value (LSB)

7	6	5	4	3	2	1	0
POUT7	POUT6	POUT5	POUT4	POUT3	POUT2	POUT1	POUT0

POUT[7:0]	This register contains the low part of the pressure output value.
-----------	---

The pressure output value is 24-bit data that contains the measured pressure. It is composed of [PRESS_OUT_H \(2Ah\)](#), [PRESS_OUT_L \(29h\)](#) and [PRESS_OUT_XL \(28h\)](#). The value is expressed as 2's complement.

The output pressure register [PRESS_OUT](#) is provided as the difference between the measured pressure and the content of the register [RPDS \(18h, 19h\)](#).

Please refer to [Section 3.5 Interpreting pressure readings](#) for additional info.

7.9 PRESS_OUT_L (29h)

Pressure output value (mid part)

7	6	5	4	3	2	1	0
POUT15	POUT14	POUT13	POUT12	POUT11	POUT10	POUT9	POUT8

POUT[15:8]	This register contains the mid part of the pressure output value. Refer to PRESS_OUT_XL (28h) .
------------	---

7.10 PRESS_OUT_H (2Ah)

Pressure output value (MSB)

7	6	5	4	3	2	1	0
POUT23	POUT22	POUT21	POUT20	POUT19	POUT18	POUT17	POUT16

POUT[23:16]	This register contains the high part of the pressure output value. Refer to PRESS_OUT_XL (28h) .
-------------	--

7.11 TEMP_OUT_L (2Bh)

Temperature output value (LSB)

7	6	5	4	3	2	1	0
TOUT7	TOUT6	TOUT5	TOUT4	TOUT3	TOUT2	TOUT1	TOUT0

TOUT[7:0]	This register contains the low part of the temperature output value.
-----------	--

The temperature output value is 16-bit data that contains the measured temperature. It is composed of [TEMP_OUT_H \(2Ch\)](#) and [TEMP_OUT_L \(2Bh\)](#). The value is expressed as 2's complement.

7.12 TEMP_OUT_H (2Ch)

Temperature output value (MSB)

7	6	5	4	3	2	1	0
TOUT15	TOUT14	TOUT13	TOUT12	TOUT11	TOUT10	TOUT9	TOUT8

TOUT[15:8]	This register contains the high part of the temperature output value.
------------	---

The temperature output value is 16-bit data that contains the measured temperature. It is composed of TEMP_OUT_H (2Ch) and TEMP_OUT_L (2Bh). The value is expressed as 2's complement.

7.13 LPFP_RES (33h)

Low-pass filter reset register.

If the LPFP is active, in order to avoid the transitory phase, the filter can be reset by reading this register before generating pressure measurements.

8 Package information

In order to meet environmental requirements, ST offers these devices in different grades of **ECOPACK** packages, depending on their level of environmental compliance. ECOPACK specifications, grade definitions and product status are available at: www.st.com. ECOPACK is an ST trademark.

8.1 CCLGA 4L package information

Figure 8. CCLGA - 4L (3.3 x 3.3 x max 2.9 mm) package outline and mechanical data

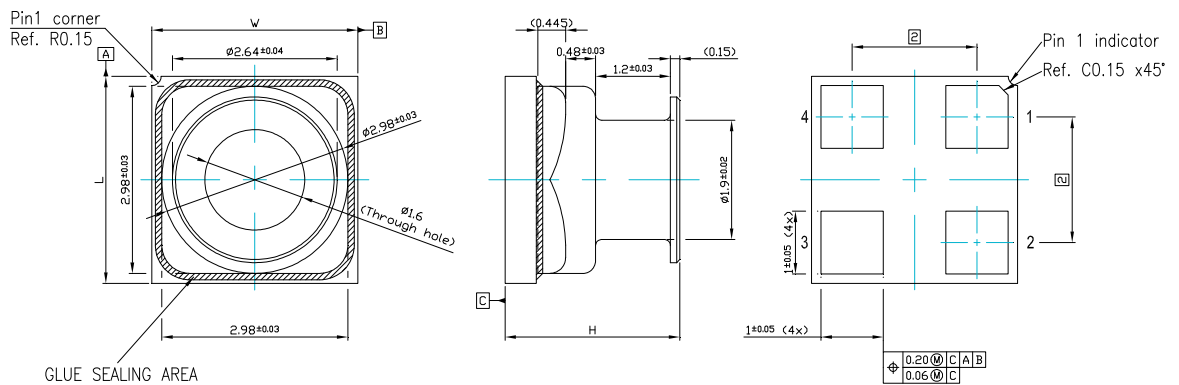

Dimensions are in millimeter unless otherwise specified
General Tolerance is +/-0.10mm unless otherwise specified

OUTER DIMENSIONS

ITEM	DIMENSION [mm]	TOLERANCE [mm]
Length [L]	3.3	±0.15
Width [W]	3.3	±0.15
Height [H]	2.9 MAX	/

DM00547458_1

8.2 CCLGA 4L packing information

Figure 9. Carrier tape information for CCLGA 4L package

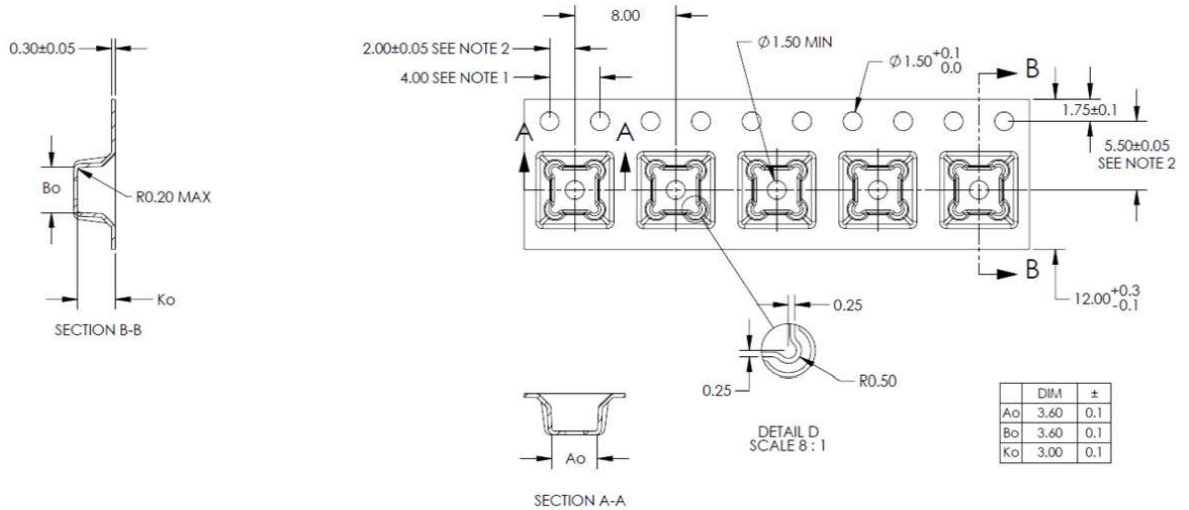

- NOTES:
1. 10 SPROCKET HOLE PITCH CUMULATIVE TOLERANCE ± 0.2
 2. POCKET POSITION RELATIVE TO SPROCKET HOLE MEASURED AS TRUE POSITION OF POCKET, NOT POCKET HOLE.
 3. Ao AND Bo ARE CALCULATED ON A PLANE AT A DISTANCE "R" ABOVE THE BOTTOM OF THE POCKET.

Figure 10. Package orientation in carrier tape

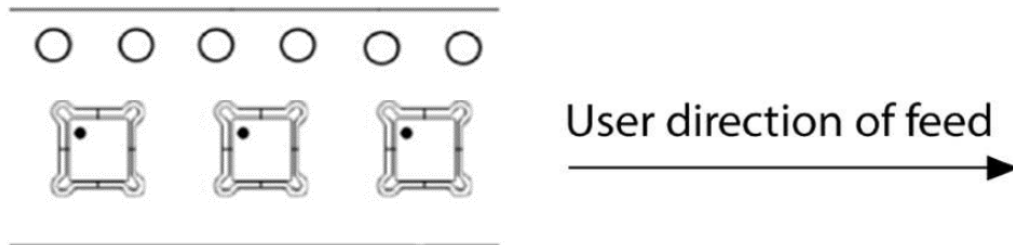

Figure 11. Reel information carrier tape CCLGA 4L

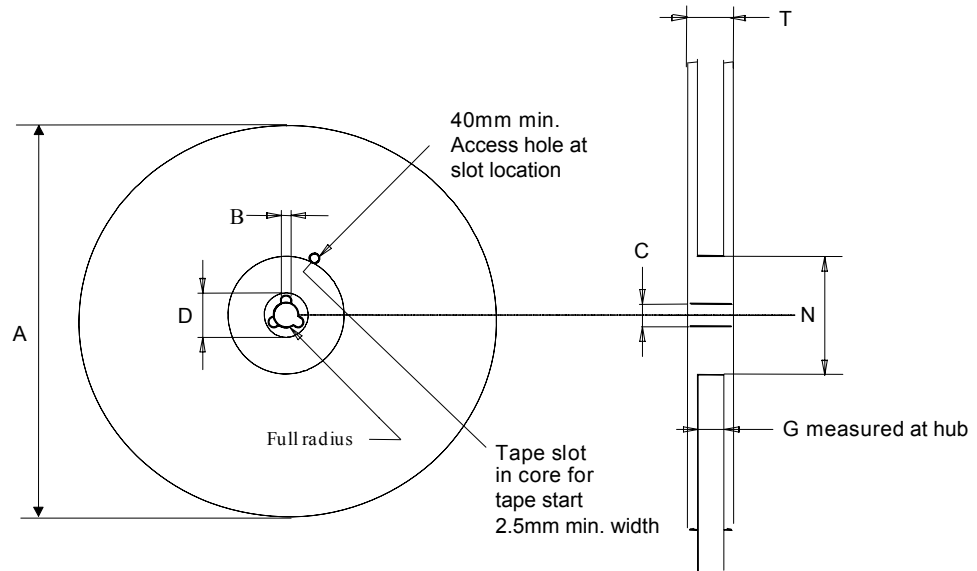

Table 18. Reel dimensions for carrier tape of CCLGA 4L package

Reel dimensions (mm)	
A (max)	330
B (min)	1.5
C	13 ±0.25
D (min)	20.2
N (min)	60
G	12.4 +2/-0
T (max)	18.4

Revision history

Table 19. Document revision history

Date	Version	Changes
20-May-2020	3	First public release

Contents

1	Block diagram and pin description	2
2	Mechanical and electrical specifications	3
2.1	Mechanical characteristics	3
2.2	Electrical characteristics	4
2.3	Communication interface characteristics	5
2.3.1	I ² C - inter-IC control interface	5
2.4	Absolute maximum ratings	6
3	Functionality	7
3.1	Sensing element	7
3.2	IC interface	7
3.3	Factory calibration	7
3.4	Device structure	8
3.5	Interpreting pressure readings	9
4	Application hints	10
4.1	Soldering information	11
5	Digital interfaces	12
5.1	IC serial interface	12
5.2	I ² C serial interface	12
5.2.1	I ² C operation	13
6	Register map	15
7	Register description	16
7.1	WHO_AM_I (0Fh)	16
7.2	CTRL_REG1 (10h)	16
7.3	CTRL_REG2 (11h)	18
7.4	RPDS_L (18h)	19
7.5	RPDS_H (19h)	19
7.6	RES_CONF (1Ah)	19
7.7	STATUS (27h)	20
7.8	PRESS_OUT_XL (28h)	20

7.9	PRESS_OUT_L (29h).....	21
7.10	PRESS_OUT_H (2Ah).....	21
7.11	TEMP_OUT_L (2Bh).....	21
7.12	TEMP_OUT_H (2Ch).....	22
7.13	LPFP_RES (33h).....	22
8	Package information.....	23
8.1	CCLGA 4L package information.....	23
8.2	CCLGA 4L packing information.....	24
	Revision history.....	26
	Contents.....	27
	List of tables.....	29
	List of figures.....	30

List of tables

Table 1.	Pin description	2
Table 2.	Pressure and temperature sensor characteristics	3
Table 3.	Electrical characteristics	4
Table 4.	DC characteristics	4
Table 5.	I ² C slave timing values	5
Table 6.	Absolute maximum ratings	6
Table 7.	Potting gel properties	8
Table 8.	Serial interface pin description	12
Table 9.	I ² C terminology	12
Table 10.	SAD+Read/Write patterns	13
Table 11.	Transfer when master is writing one byte to slave	13
Table 12.	Transfer when master is writing multiple bytes to slave	13
Table 13.	Transfer when master is receiving (reading) one byte of data from slave	13
Table 14.	Transfer when master is receiving (reading) multiple bytes of data from slave	13
Table 15.	Registers address map	15
Table 16.	Output data rate bit configurations	16
Table 17.	Low-pass filter configurations	17
Table 18.	Reel dimensions for carrier tape of CCLGA 4L package	25
Table 19.	Document revision history	26

List of figures

Figure 1.	Block diagram	2
Figure 2.	Pin connections (bottom view)	2
Figure 3.	I ² C slave timing diagram	5
Figure 4.	LPS33K internal structure	8
Figure 5.	Pressure readings.	9
Figure 6.	LPS33K electrical connections (bottom view)	10
Figure 7.	LPS33K power-off sequence	10
Figure 8.	CCLGA - 4L (3.3 x 3.3 x max 2.9 mm) package outline and mechanical data	23
Figure 9.	Carrier tape information for CCLGA 4L package	24
Figure 10.	Package orientation in carrier tape	24
Figure 11.	Reel information carrier tape CCLGA 4L	25

IMPORTANT NOTICE – PLEASE READ CAREFULLY

STMicroelectronics NV and its subsidiaries (“ST”) reserve the right to make changes, corrections, enhancements, modifications, and improvements to ST products and/or to this document at any time without notice. Purchasers should obtain the latest relevant information on ST products before placing orders. ST products are sold pursuant to ST’s terms and conditions of sale in place at the time of order acknowledgement.

Purchasers are solely responsible for the choice, selection, and use of ST products and ST assumes no liability for application assistance or the design of Purchasers’ products.

No license, express or implied, to any intellectual property right is granted by ST herein.

Resale of ST products with provisions different from the information set forth herein shall void any warranty granted by ST for such product.

ST and the ST logo are trademarks of ST. For additional information about ST trademarks, please refer to www.st.com/trademarks. All other product or service names are the property of their respective owners.

Information in this document supersedes and replaces information previously supplied in any prior versions of this document.

© 2020 STMicroelectronics – All rights reserved

X-ON Electronics

Largest Supplier of Electrical and Electronic Components

Click to view similar products for [Board Mount Pressure Sensors](#) category:

Click to view products by [STMicroelectronics](#) manufacturer:

Other Similar products are found below :

[6407-249V-17343P](#) [6407-250V-09273P](#) [80527-25.0H2-05](#) [80541-B00000150-01](#) [80541-B00000200-05](#) [80554-00700100-05](#) [80568-00300050-01](#) [93.631.4253.0](#) [93.731.4353.0](#) [93.932.4553.0](#) [136PC150G2](#) [136PC15A1](#) [142PC95AW71](#) [142PC05DW70](#) [15PSI-G-4V](#) [1805-01A-L0N-B](#) [26PCBKT](#) [26PCCFA6D26](#) [26PCCFS2G](#) [26PCCVA6D](#) [93.632.7353.0](#) [93.731.3653.0](#) [93.931.4853.0](#) [93.932.4853.0](#) [SCDA120-XSC05DC](#) [185PC30DH](#) [20INCH-G-MV-MINI](#) [26PCAFJ3G](#) [26PCCEP5G24](#) [26PCDFA3G](#) [26PCJEU5G19](#) [ASCX15AN-90](#) [TSCSAAN001PDUCV](#) [DCAL401DN](#) [DCAL401GN](#) [XZ202798SSC](#) [XZ203676HSC](#) [6407-249V-09343P](#) [6407-250V-17343P](#) [SP370-25-116-0](#) [81794-B00001200-01](#) [HSCDLNN100PGAA5](#) [82681-B00000100-01](#) [81618-B00000040-05](#) [SSCDJNN015PAAA5](#) [TSCDLNN100MDUCV](#) [TSCSAAN100PDUCV](#) [NBPDANN015PGUNV](#) [NBPLLNS150PGUNV](#) [142PC100D](#)