

Automotive-grade low voltage PNP power transistor

Datasheet - production data

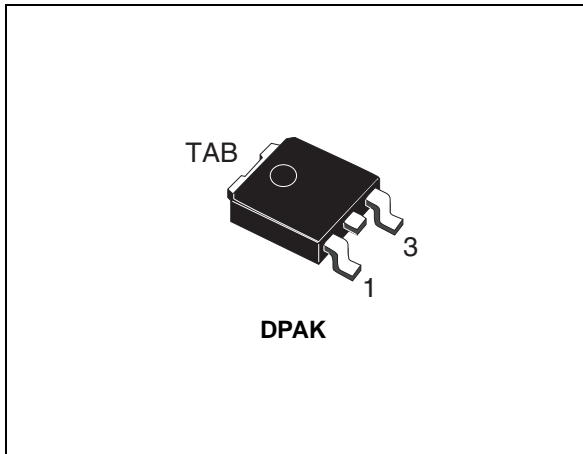
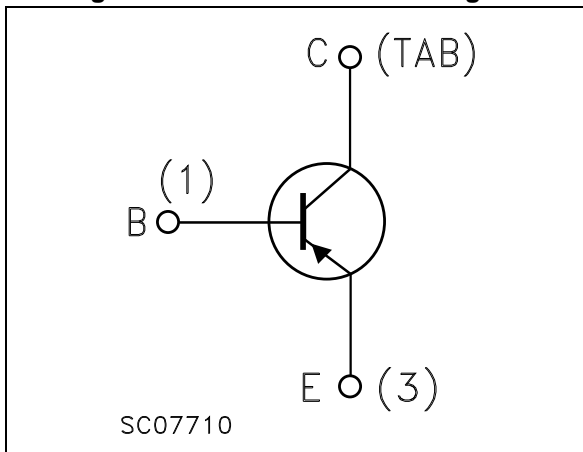



Figure 1. Internal schematic diagram



Features

- AEC-Q101 qualified 
- Surface-mounting TO-252 power package in tape and reel
- Complementary to the NPN type MJD31CT4-A

Applications

- General purpose linear and switching equipment

Description

The device is manufactured in planar technology with “base island” layout. The resulting transistor shows exceptional high gain performance coupled with very low saturation voltage.

Table 1. Device summary

Order code	Marking	Package	Packing
MJD32CT4-A	MJD32C	DPAK	Tape and reel

Contents

1	Electrical ratings	3
2	Electrical characteristics	4
2.1	Electrical characteristics (curves)	5
3	Test circuits	7
4	Package information	8
4.1	DPAK (TO-252) type A package information	8
4.2	DPAK (TO-252) packing information	11
5	Revision history	13

1 Electrical ratings

Table 2. Absolute maximum ratings

Symbol	Parameter	Value	Unit
V _{CB0}	Collector-base voltage ($I_E = 0$)	-100	V
V _{CEO}	Collector-emitter voltage ($I_B = 0$)	-100	V
V _{EBO}	Emitter-base voltage ($I_C = 0$)	-5	V
I _C	Collector current	-3	A
I _{CM}	Collector peak current	-5	A
I _B	Base current	-1	A
P _{TOT}	Total dissipation at T _C = 25 °C	15	W
T _{stg}	Storage temperature range	-65 to 150	°C
T _j	Operating junction temperature range		

Table 3. Thermal data

Symbol	Parameter	Value	Unit
R _{thj-case}	Thermal resistance junction-case	8.3	°C/W
R _{thj-pcb} ⁽¹⁾	Thermal resistance junction-pcb	50	°C/W

1. When mounted on a 1-inch² FR-4 board, 2oz Cu

2 Electrical characteristics

$T_{\text{case}}=25\text{ }^{\circ}\text{C}$ unless otherwise specified.

Table 4. On/off states

Symbol	Parameter	Test conditions	Min.	Typ.	Max.	Unit
I_{CES}	Collector cut-off current ($V_{\text{BE}} = 0$)	$V_{\text{CE}} = -100\text{ V}$		-	-20	μA
I_{CEO}	Collector cut-off current ($I_{\text{B}} = 0$)	$V_{\text{CB}} = -60\text{ V}$		-	-50	μA
I_{EBO}	Emitter cut-off current ($I_{\text{C}} = 0$)	$V_{\text{EB}} = -5\text{ V}$		-	-0.1	mA
$V_{\text{CEO(sus)}}$	Collector-emitter sustaining voltage ($I_{\text{B}} = 0$)	$I_{\text{C}} = -30\text{ mA}$	-100	-		V
$V_{\text{CE(sat)}}^{(1)}$	Collector-emitter saturation voltage	$I_{\text{C}} = -3\text{ A}$, $I_{\text{B}} = -375\text{ mA}$		-	-1.2	V
$V_{\text{BE(on)}}$	Base-emitter on voltage	$I_{\text{C}} = -3\text{ A}$, $V_{\text{CE}} = -4\text{ V}$		-	-1.8	V
h_{FE}	DC current gain	$I_{\text{C}} = -1\text{ A}$, $V_{\text{CE}} = -4\text{ V}$	25	-		
		$I_{\text{C}} = -3\text{ A}$, $V_{\text{CE}} = -4\text{ V}$	10	-	50	

1. Pulse test: pulse duration $\leq 300\text{ }\mu\text{s}$, duty cycle $\leq 2\%$

2.1 Electrical characteristics (curves)

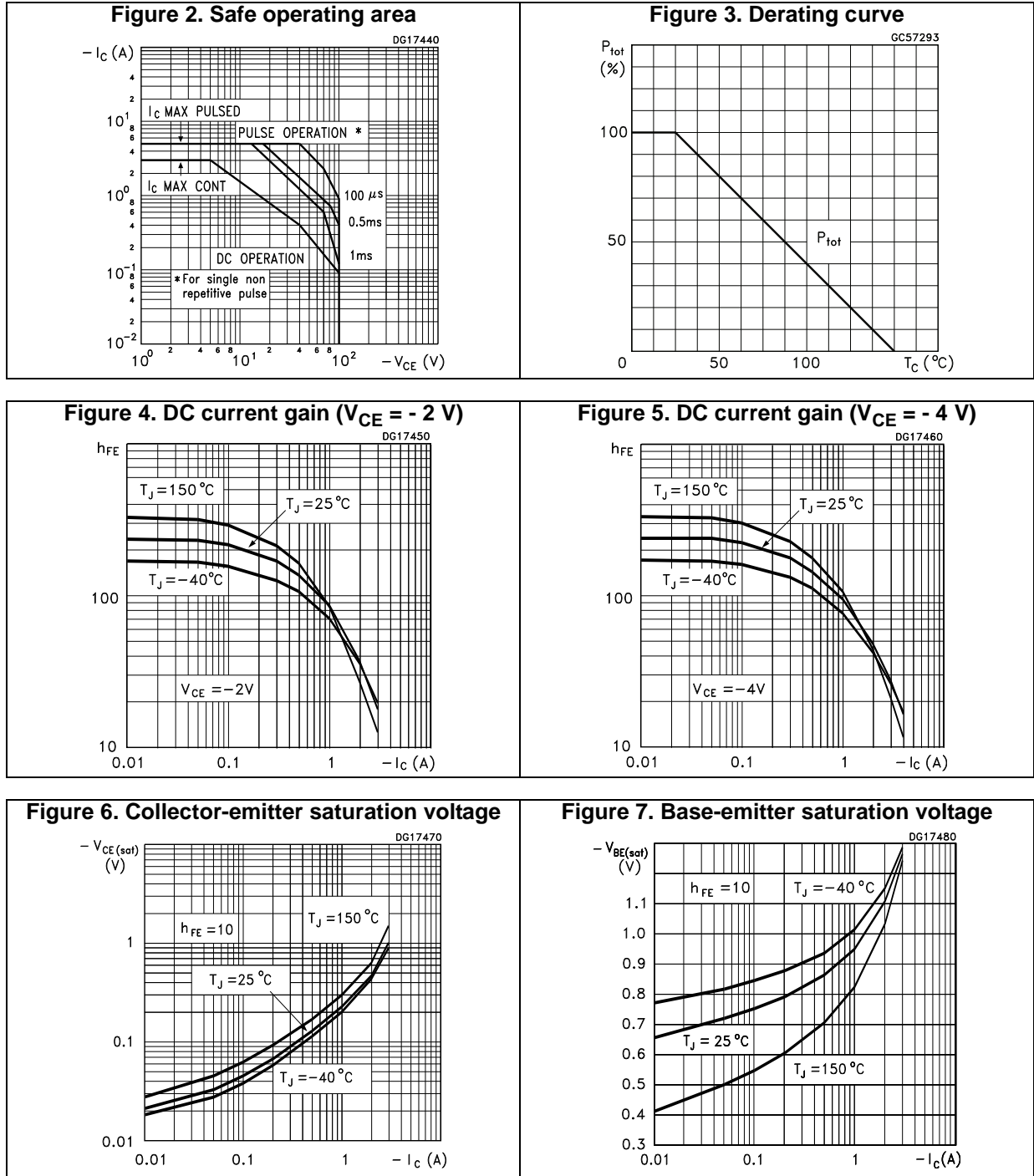

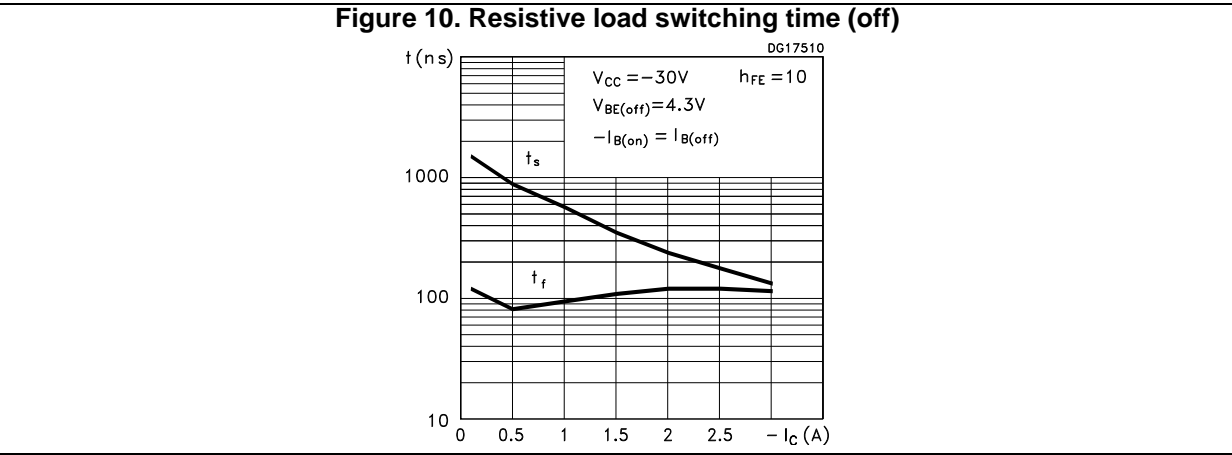
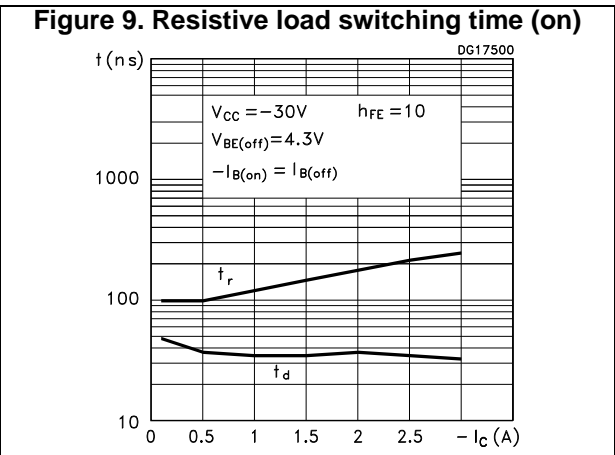
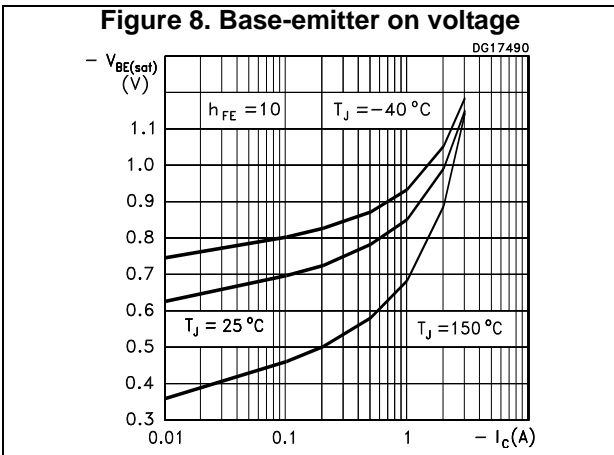

3 Test circuits

Figure 11. Resistive load switching test circuit

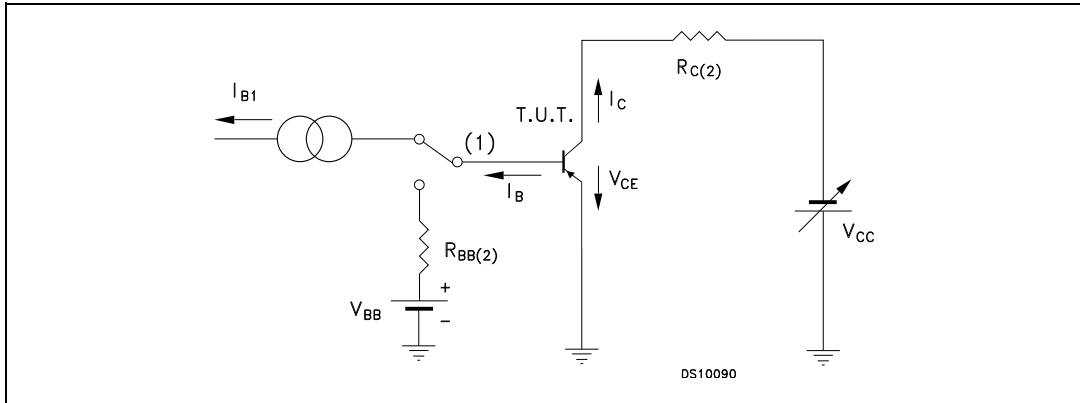

1. Fast electronic switch
2. Non-inductive resistor

Figure 12. Inductive load switching test circuit

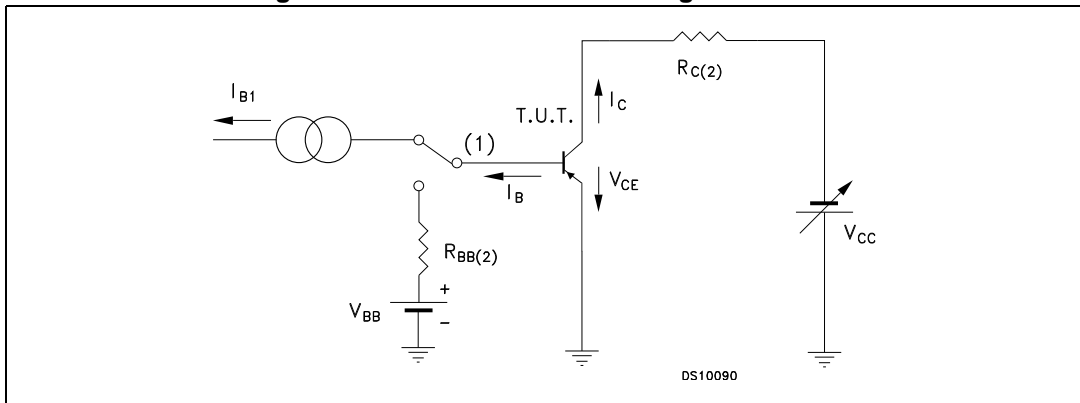

1. Fast electronic switch
2. Non-inductive resistor
3. Fast recovery rectifier

4 Package information

In order to meet environmental requirements, ST offers these devices in different grades of ECOPACK[®] packages, depending on their level of environmental compliance. ECOPACK[®] specifications, grade definitions and product status are available at: www.st.com. ECOPACK[®] is an ST trademark.

4.1 DPAK (TO-252) type A package information

Figure 13. DPAK (TO-252) type A package outline

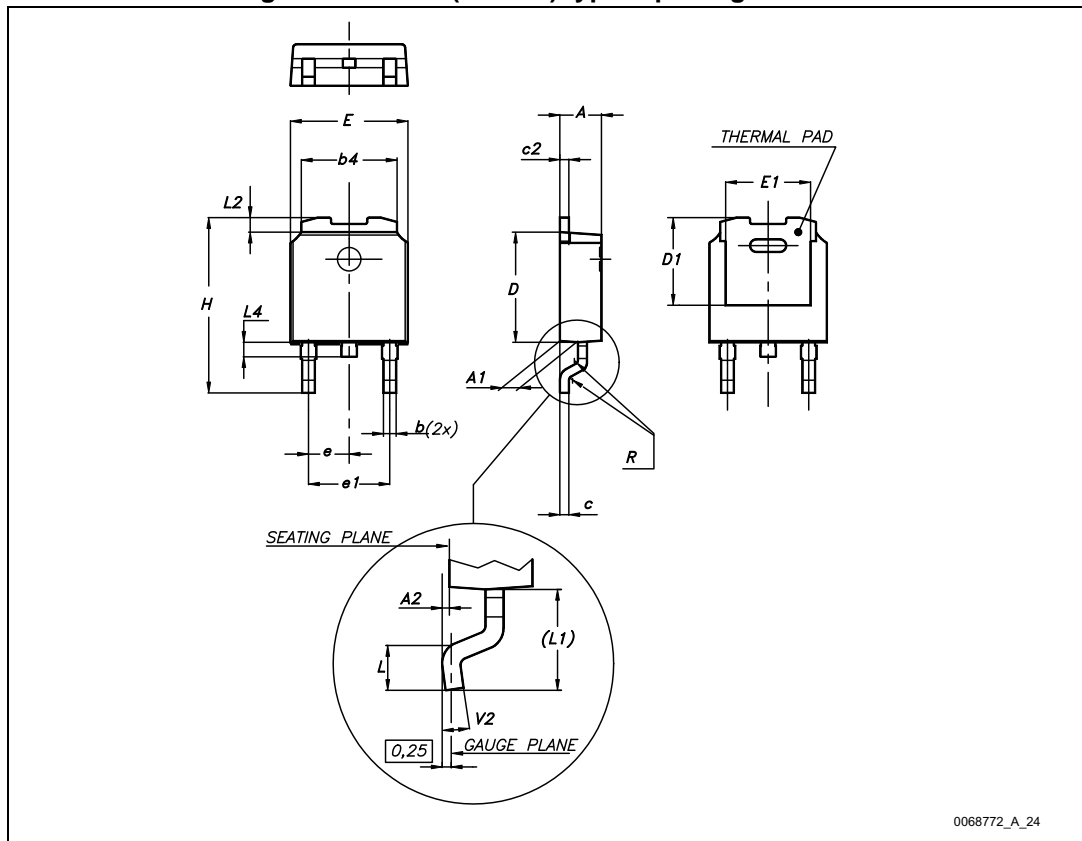
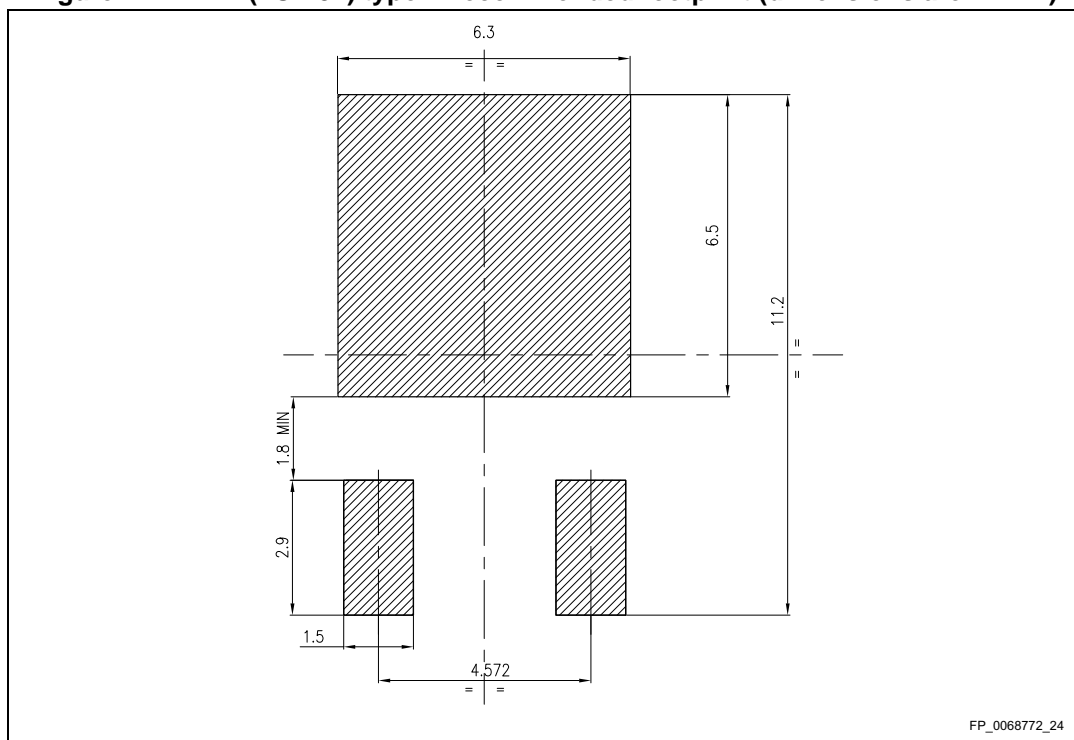

Table 5. DPAK (TO-252) type A mechanical data

Dim.	mm		
	Min.	Typ.	Max.
A	2.20		2.40
A1	0.90		1.10
A2	0.03		0.23
b	0.64		0.90
b4	5.20		5.40
c	0.45		0.60
c2	0.48		0.60
D	6.00		6.20
D1	4.95	5.10	5.25
E	6.40		6.60
E1	4.60	4.70	4.80
e	2.16	2.28	2.40
e1	4.40		4.60
H	9.35		10.10
L	1.00		1.50
(L1)	2.60	2.80	3.00
L2	0.65	0.80	0.95
L4	0.60		1.00
R		0.20	
V2	0°		8°

Figure 14. DPAK (TO-252) type A recommended footprint (dimensions are in mm)



4.2 DPAK (TO-252) packing information

Figure 15. DPAK (TO-252) tape outline

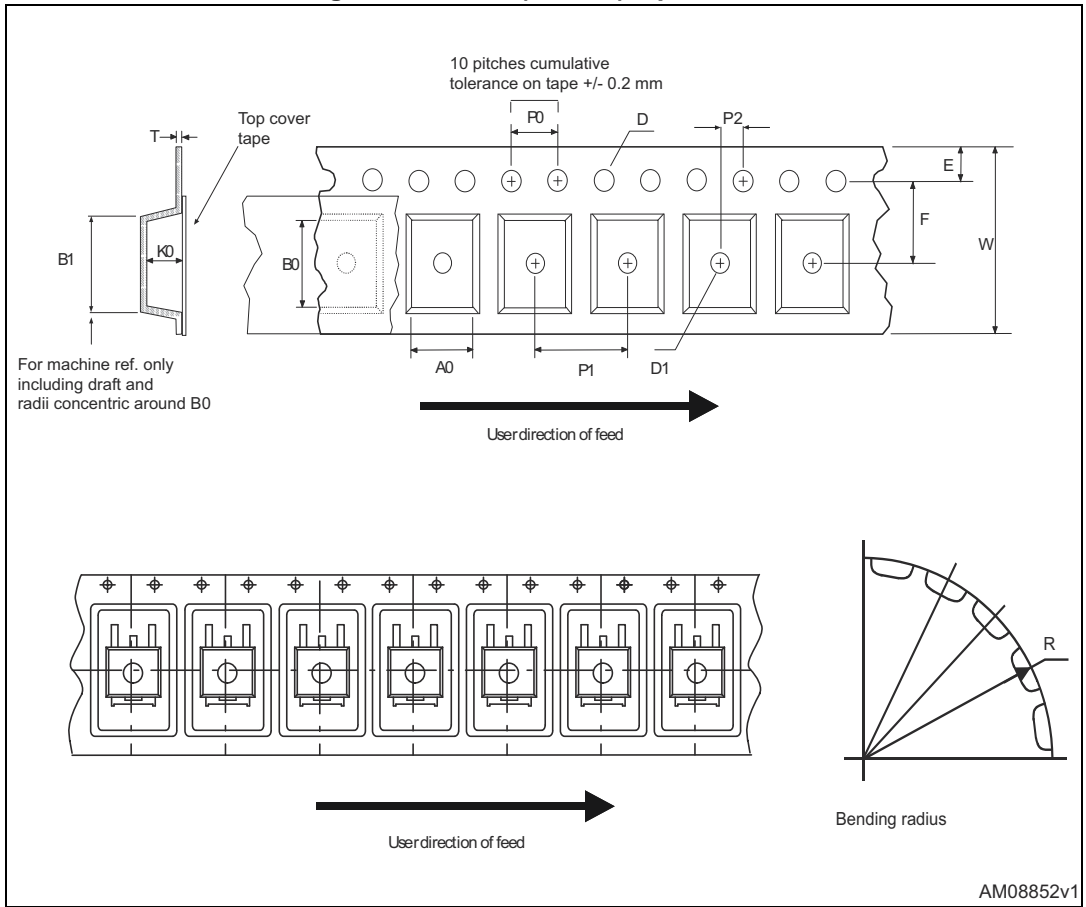
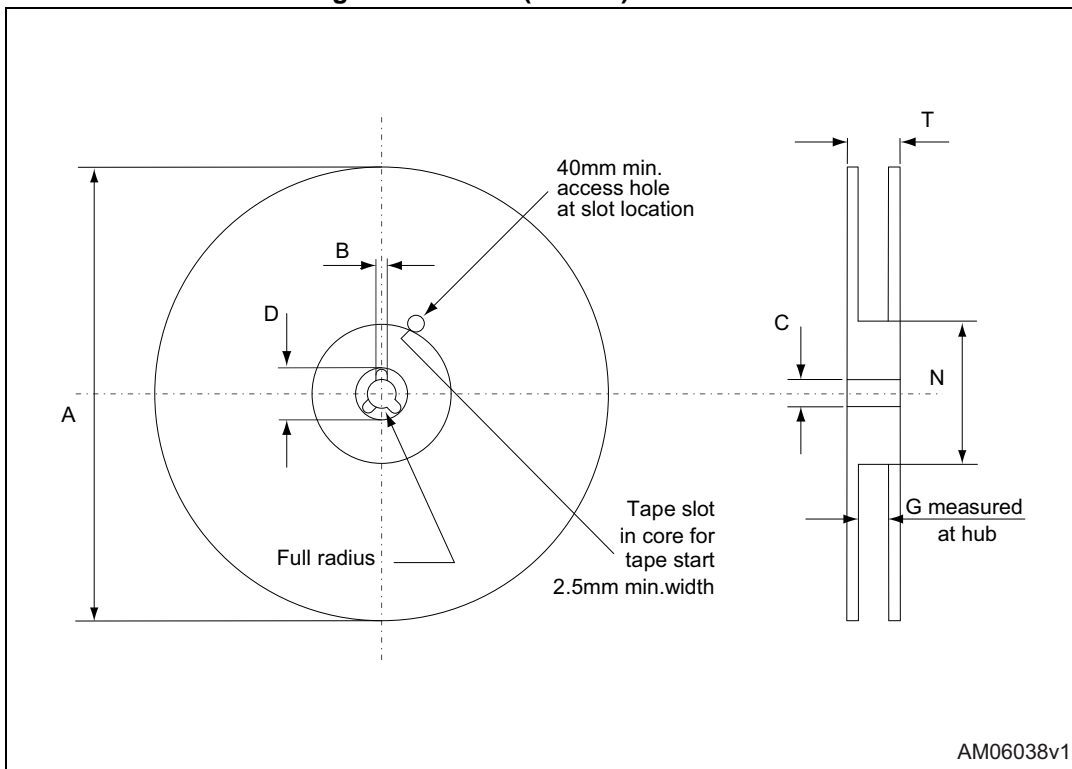

Figure 16. DPAK (TO-252) reel outline



AM06038v1

Table 6. DPAK (TO-252) tape and reel mechanical data

Tape			Reel		
Dim.	mm		Dim.	mm	
	Min.	Max.		Min.	Max.
A0	6.8	7	A		330
B0	10.4	10.6	B	1.5	
B1		12.1	C	12.8	13.2
D	1.5	1.6	D	20.2	
D1	1.5		G	16.4	18.4
E	1.65	1.85	N	50	
F	7.4	7.6	T		22.4
K0	2.55	2.75			
P0	3.9	4.1	Base qty.		2500
P1	7.9	8.1	Bulk qty.		2500
P2	1.9	2.1			
R	40				
T	0.25	0.35			
W	15.7	16.3			

5 Revision history

Table 7. Document revision history

Date	Revision	Changes
01-Jun-2007	1	First release
09-Nov-2009	2	Updated package mechanical data.
14-Jan-2010	3	Modified <i>Table 3 on page 2</i> .
19-Jun-2012	4	Modified: mechanical data updated
24-Jan-2018	5	Modified title. Modified features on cover page. Updated Section 4: Package information . Minor text changes.

IMPORTANT NOTICE – PLEASE READ CAREFULLY

STMicroelectronics NV and its subsidiaries ("ST") reserve the right to make changes, corrections, enhancements, modifications, and improvements to ST products and/or to this document at any time without notice. Purchasers should obtain the latest relevant information on ST products before placing orders. ST products are sold pursuant to ST's terms and conditions of sale in place at the time of order acknowledgement.

Purchasers are solely responsible for the choice, selection, and use of ST products and ST assumes no liability for application assistance or the design of Purchasers' products.

No license, express or implied, to any intellectual property right is granted by ST herein.

Resale of ST products with provisions different from the information set forth herein shall void any warranty granted by ST for such product.

ST and the ST logo are trademarks of ST. All other product or service names are the property of their respective owners.

Information in this document supersedes and replaces information previously supplied in any prior versions of this document.

© 2018 STMicroelectronics – All rights reserved

X-ON Electronics

Largest Supplier of Electrical and Electronic Components

Click to view similar products for [Bipolar Transistors - BJT category](#):

Click to view products by [STMicroelectronics manufacturer](#):

Other Similar products are found below :

[619691C](#) [MCH4017-TL-H](#) [BC546/116](#) [BC557/116](#) [BSW67A](#) [NTE158](#) [NTE187A](#) [NTE195A](#) [NTE2302](#) [NTE2330](#) [NTE63](#) [C4460](#)
[2SA1419T-TD-H](#) [2SA1721-O\(TE85L,F\)](#) [2SA2126-E](#) [2SB1204S-TL-E](#) [2SC5488A-TL-H](#) [2SD2150T100R](#) [SP000011176](#) [FMMTA92QTA](#)
[2N2369ADCSM](#) [2SC2412KT146S](#) [2SC5490A-TL-H](#) [2SD1816S-TL-E](#) [2SD1816T-TL-E](#) [CMXT2207 TR](#) [CPH6501-TL-E](#) [MCH4021-TL-E](#)
[US6T6TR](#) [732314D](#) [CMXT3906 TR](#) [CPH3121-TL-E](#) [CPH6021-TL-H](#) [873787E](#) [IMZ2AT108](#) [UMX21NTR](#) [EMT2T2R](#) [MCH6102-TL-E](#)
[FP204-TL-E](#) [NJL0302DG](#) [2N3583](#) [2SA1434-TB-E](#) [2SC3143-4-TB-E](#) [2SD1621S-TD-E](#) [NTE103](#) [30A02MH-TL-E](#) [NSV40301MZ4T1G](#)
[NTE101](#) [NTE13](#) [NTE15](#)