

Low voltage complementary power transistors

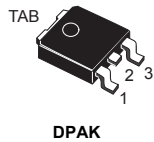

DPAK

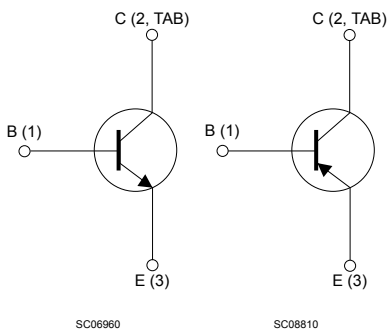

SC06960

SC08810



Features

- Low collector-emitter saturation voltage
- Fast switching speed

Application

- General purpose switching and amplifier

Description

These devices are manufactured using low voltage multi epitaxial planar technology. They are intended for general-purpose linear and switching applications.

Product status links

[MJD44H11T4](#)
[MJD45H11T4](#)

Product summary

Order code	MJD44H11T4
Marking	MJD44H11
Polarity	NPN
Package	DPAK
Packing	Tape and reel
Order code	MJD45H11T4
Marking	MJD45H11
Polarity	PNP
Package	DPAK
Packing	Tape and reel

1 Electrical ratings

Table 1. Absolute maximum ratings

Symbol	Parameter	Value	Unit
V_{CEO}	Collector-emitter voltage ($I_B = 0$ A)	80	V
V_{EBO}	Collector-base voltage ($I_C = 0$ A)	5	V
I_C	Collector current	8	A
I_{CM}	Collector peak current	16	A
P_{TOT}	Total power dissipation at $T_C = 25^\circ\text{C}$	20	W
T_{stg}	Storage temperature range	-55 to 150	$^\circ\text{C}$
T_J	Maximum operating junction temperature	150	$^\circ\text{C}$

Note: For PNP types voltage and current values are negative.

Table 2. Thermal data

Symbol	Parameter	Value	Unit
R_{thJC}	Thermal resistance, junction-to-case	6.25	$^\circ\text{C/W}$
R_{thJA}	Thermal resistance, junction-to-ambient	100	$^\circ\text{C/W}$

2 Electrical characteristics

$T_C = 25^\circ\text{C}$ unless otherwise specified.

Table 3. Electrical characteristics

Symbol	Parameter	Test conditions	Min.	Typ.	Max.	Unit
$V_{CEO(sus)}^{(1)}$	Collector-emitter sustaining voltage	$I_C = 30\text{ mA}, I_B = 0\text{ A}$	60	-		V
I_{CES}	Collector cut-off current	$V_{CE} = 80\text{ V}, V_{BE} = 0\text{ V}$		-	10	μA
I_{EBO}	Emitter cut-off current	$V_{EB} = 5\text{ V}, I_C = 0\text{ A}$		-	50	μA
$V_{CE(sat)}^{(1)}$	Collector-emitter saturation voltage	$I_C = 8\text{ A}, I_B = 0.4\text{ A}$		-	1	V
$V_{BE(sat)}^{(1)}$	Base-emitter saturation voltage	$I_C = 8\text{ A}, I_B = 0.8\text{ A}$		-	1.5	V
$h_{FE}^{(1)}$	DC current gain	$I_C = 2\text{ A}, V_{CE} = 1\text{ V}$	60	-		
		$I_C = 4\text{ A}, V_{CE} = 1\text{ V}$	40	-		

1. Pulsed: Pulse duration $\leq 300\ \mu\text{s}$, duty cycle $\leq 2\%$.

Note: For PNP types voltage and current values are negative.

2.1 Electrical characteristics (curves)

Figure 1. Safe operating area

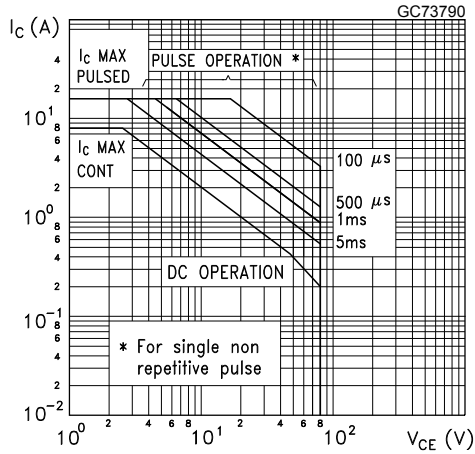

Figure 2. Derating curves

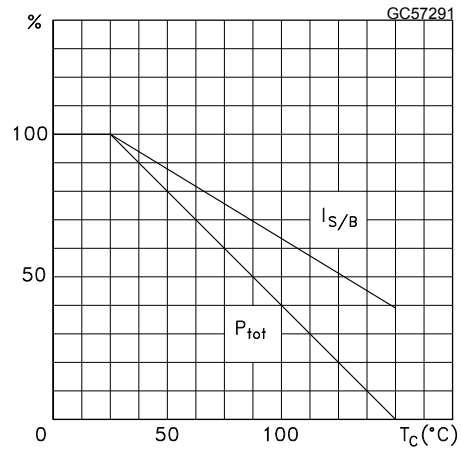

Figure 3. DC current gain (NPN)

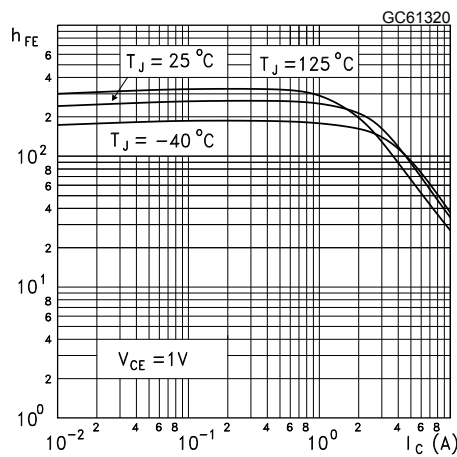

Figure 4. DC current gain (PNP)

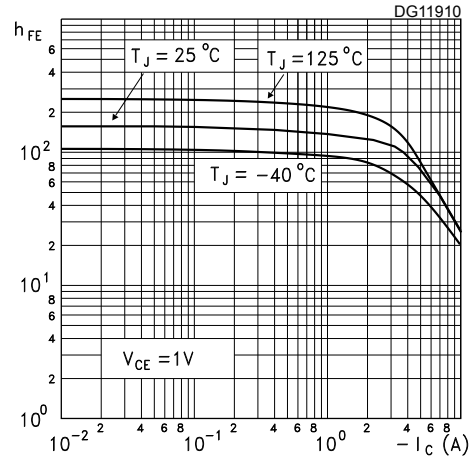

Figure 5. Collector-emitter saturation voltage (NPN)

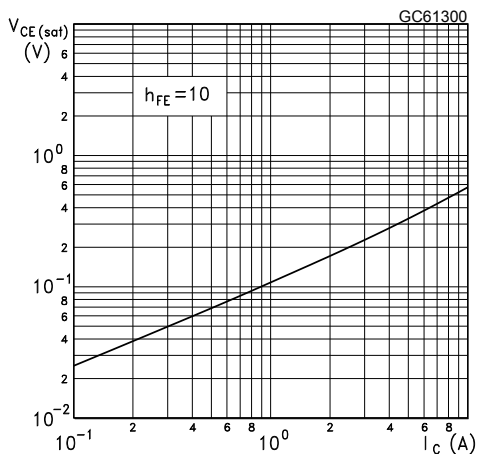
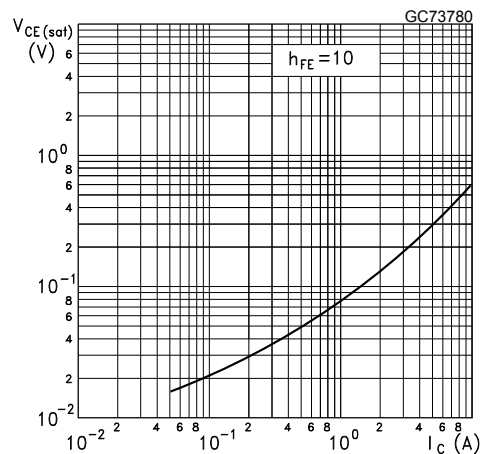

Figure 6. Collector-emitter saturation voltage (PNP)



3 Package information

In order to meet environmental requirements, ST offers these devices in different grades of **ECOPACK** packages, depending on their level of environmental compliance. ECOPACK specifications, grade definitions and product status are available at: www.st.com. ECOPACK is an ST trademark.

3.1 DPAK (TO-252) type C2 package information

Figure 7. DPAK (TO-252) type C2 package outline

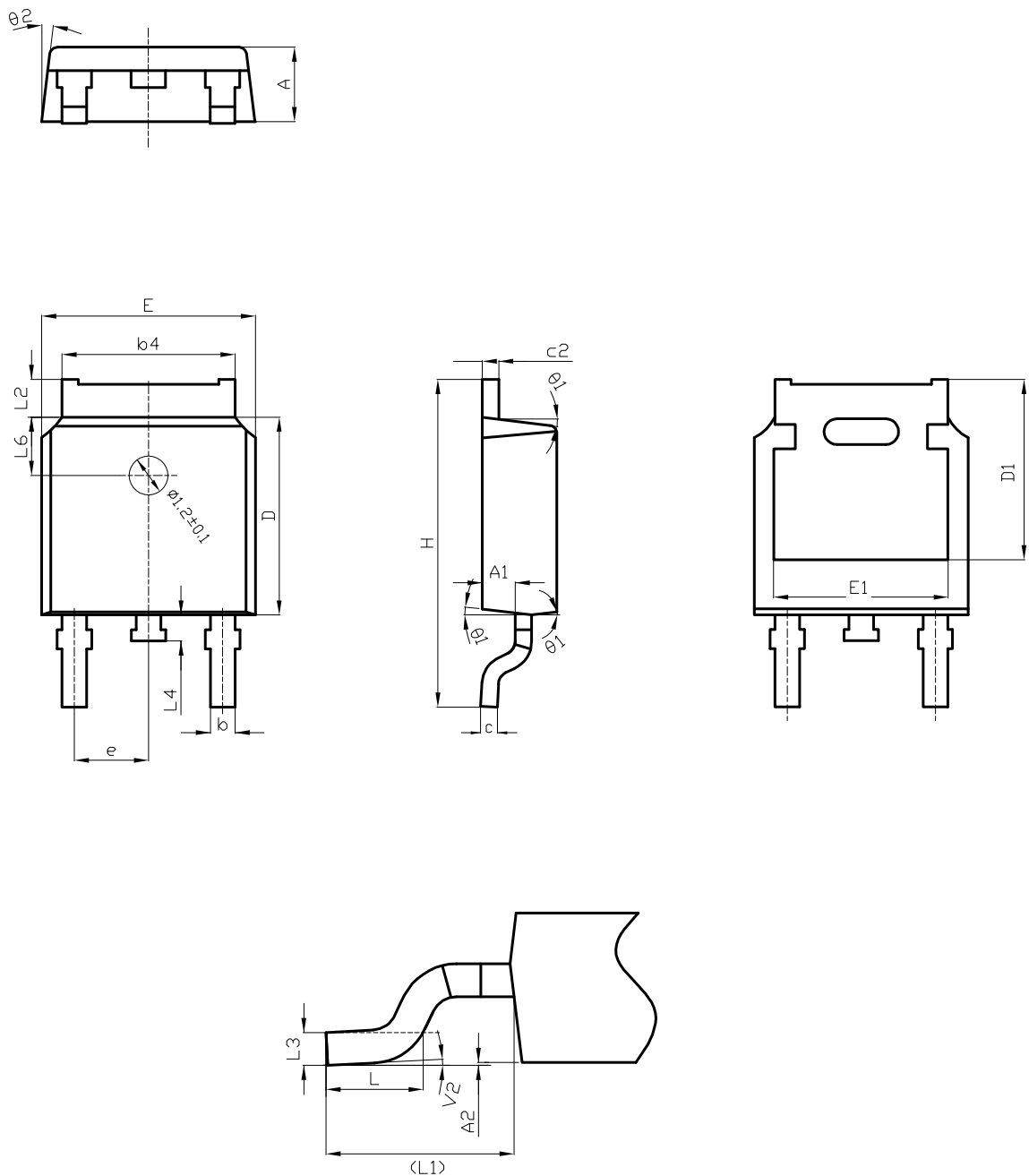

0068772_type-C2_rev30

Table 4. DPAK (TO-252) type C2 mechanical data

Dim.	mm		
	Min.	Typ.	Max.
A	2.20	2.30	2.38
A1	0.90	1.01	1.10
A2	0.00		0.10
b	0.72		0.85
b4	5.13	5.33	5.46
c	0.47		0.60
c2	0.47		0.60
D	6.00	6.10	6.20
D1	5.10		5.60
E	6.50	6.60	6.70
E1	5.20		5.50
e	2.186	2.286	2.386
H	9.80	10.10	10.40
L	1.40	1.50	1.70
L1	2.90 REF		
L2	0.90		1.25
L3	0.51 BSC		
L4	0.60	0.80	1.00
L6	1.80 BSC		
θ1	5°	7°	9°
θ2	5°	7°	9°
V2	0°		8°

Figure 8. DPAK (TO-252) recommended footprint (dimensions are in mm)

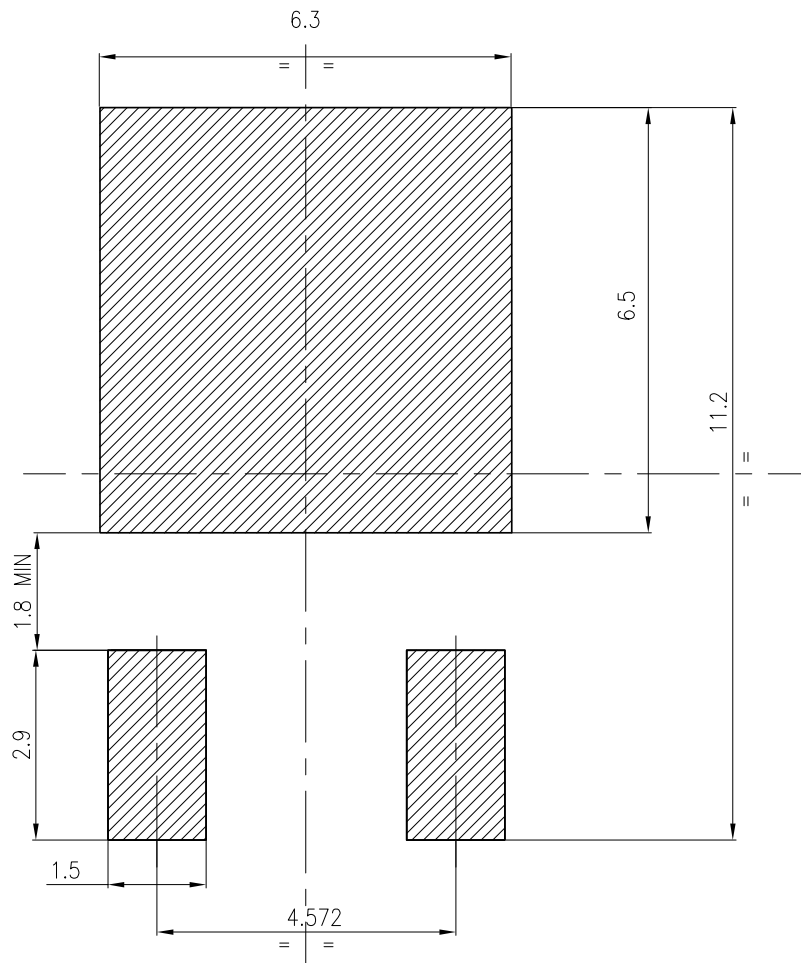

FP_0068772_30

3.2 DPAK (TO-252) packing information

Figure 9. DPAK (TO-252) tape outline

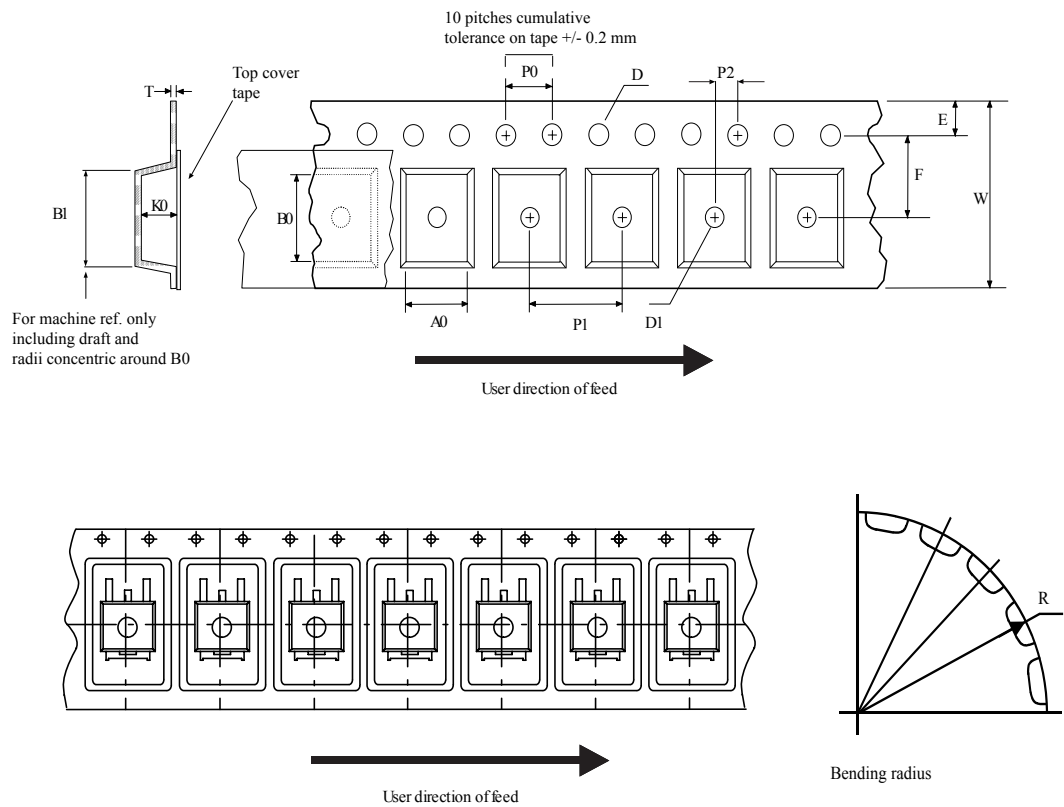

AM08852v1

Figure 10. DPAK (TO-252) reel outline

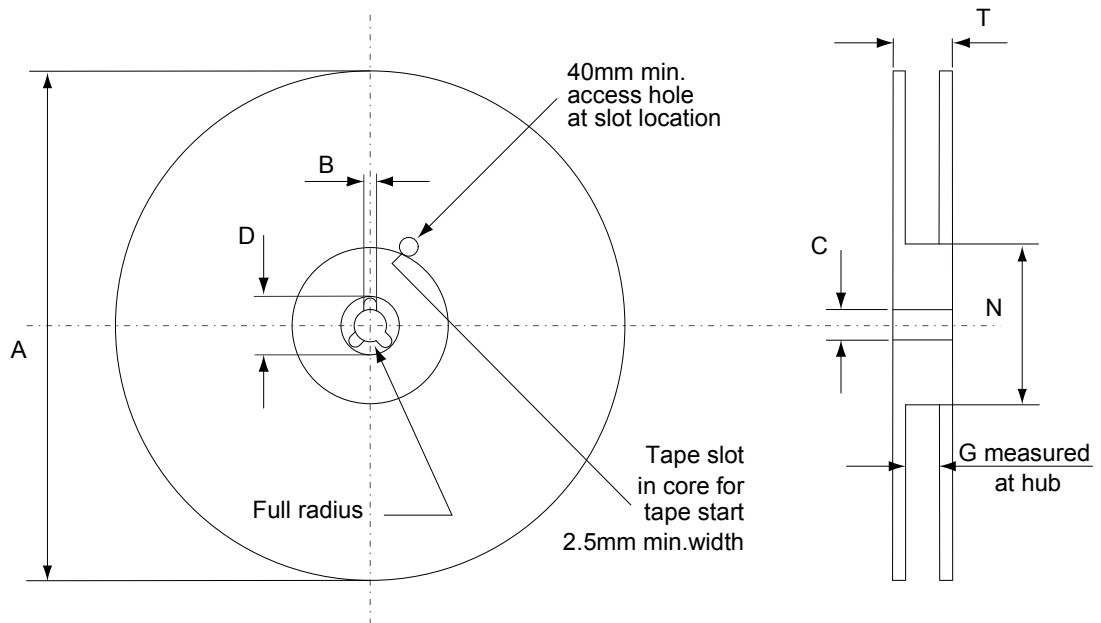

AM06038v1

Table 5. DPAK (TO-252) tape and reel mechanical data

Tape			Reel		
Dim.	mm		Dim.	mm	
	Min.	Max.		Min.	Max.
A0	6.8	7	A		330
B0	10.4	10.6	B	1.5	
B1		12.1	C	12.8	13.2
D	1.5	1.6	D	20.2	
D1	1.5		G	16.4	18.4
E	1.65	1.85	N	50	
F	7.4	7.6	T		22.4
K0	2.55	2.75			
P0	3.9	4.1	Base qty.		2500
P1	7.9	8.1	Bulk qty.		2500
P2	1.9	2.1			
R	40				
T	0.25	0.35			
W	15.7	16.3			

Revision history

Table 6. Document revision history

Date	Version	Changes
21-Jun-2004	2	Document migration, no content change.
06-Aug-2009	3	Updated mechanical data.
18-May-2012	4	Updated: mechanical data Inserted: packaging mechanical data
05-May-2021	5	Updated title, Features and added STPOWER LOGO in cover page. Updated Table 2. Thermal data. Updated Section 3 Package information. Minor text changes.

Contents

1	Electrical ratings	2
2	Electrical characteristics	3
2.1	Electrical characteristics (curves)	4
3	Package information	5
3.1	DPAK (TO-252) type C2 package information	5
3.2	DPAK (TO-252) packing information	8
	Revision history	10

IMPORTANT NOTICE – PLEASE READ CAREFULLY

STMicroelectronics NV and its subsidiaries (“ST”) reserve the right to make changes, corrections, enhancements, modifications, and improvements to ST products and/or to this document at any time without notice. Purchasers should obtain the latest relevant information on ST products before placing orders. ST products are sold pursuant to ST’s terms and conditions of sale in place at the time of order acknowledgement.

Purchasers are solely responsible for the choice, selection, and use of ST products and ST assumes no liability for application assistance or the design of Purchasers’ products.

No license, express or implied, to any intellectual property right is granted by ST herein.

Resale of ST products with provisions different from the information set forth herein shall void any warranty granted by ST for such product.

ST and the ST logo are trademarks of ST. For additional information about ST trademarks, please refer to www.st.com/trademarks. All other product or service names are the property of their respective owners.

Information in this document supersedes and replaces information previously supplied in any prior versions of this document.

© 2021 STMicroelectronics – All rights reserved

X-ON Electronics

Largest Supplier of Electrical and Electronic Components

Click to view similar products for [Bipolar Transistors - BJT category](#):

Click to view products by [STMicroelectronics manufacturer](#):

Other Similar products are found below :

[619691C](#) [MCH4017-TL-H](#) [BC546/116](#) [BC557/116](#) [BSW67A](#) [NTE158](#) [NTE187A](#) [NTE195A](#) [NTE2302](#) [NTE2330](#) [NTE63](#) [C4460](#)
[2SA1419T-TD-H](#) [2SA1721-O\(TE85L,F\)](#) [2SA2126-E](#) [2SB1204S-TL-E](#) [2SC5488A-TL-H](#) [2SD2150T100R](#) [SP000011176](#) [FMMTA92QTA](#)
[2N2369ADCSM](#) [2SC2412KT146S](#) [2SC5490A-TL-H](#) [2SD1816S-TL-E](#) [2SD1816T-TL-E](#) [CMXT2207 TR](#) [CPH6501-TL-E](#) [MCH4021-TL-E](#)
[US6T6TR](#) [NJL0281DG](#) [732314D](#) [CMXT3906 TR](#) [CPH3121-TL-E](#) [CPH6021-TL-H](#) [873787E](#) [IMZ2AT108](#) [UMX21NTR](#) [EMT2T2R](#)
[MCH6102-TL-E](#) [FP204-TL-E](#) [NJL0302DG](#) [2N3583](#) [2SA1434-TB-E](#) [2SC3143-4-TB-E](#) [2SD1621S-TD-E](#) [NTE103](#) [30A02MH-TL-E](#)
[NSV40301MZ4T1G](#) [NTE101](#) [NTE13](#)