

# ESD, overvoltage and overcurrent protection with charging orientation direction detection for wearables and IoT



WLCSP package  
(13 bumps)



Product status link

[OCVPB21-13F6](#)

## Features

- USB interface protection between cable and charging circuit during battery charging with:
  - Exceeds ESD IEC 61000-4-2 level 4 protection on cable side:  $\pm 15$  kV contact on bridge inputs,  $\pm 12$  kV contact on USB data-lines inputs
  - Detection of the polarity of the charging cable with rerouting in case of cable inversion thanks to 13 V input rectification bridge
  - Overvoltage protection (OVP) up to  $\pm 13$  V
  - Over current protection (OCP) externally adjustable from 100 mA to 500 mA
  - Controlled inrush current
  - Over temperature protection
  - Under-voltage lockout
  - 5 V USB 2.0 data lines protection and multiplexer for data line polarity correction ( $R_{ON} = 6 \Omega$  typical)
  - $\overline{FLAG}$  output signal (open-drain) available to inform thermal shutdown or overvoltage or overcurrent or uncompleted start-up phase
  - Proposed in 400 $\mu$ m pitch WLCSP package 13 bumps
  - Operating temperature from  $-30^{\circ}\text{C}$  to  $65^{\circ}\text{C}$

## Benefits

- Minimal PCB footprint in wearable, IoT, mobile phone, tablet and all USB devices applications thanks to very strong integration
- High voltage protection management to give flexibility to customers to use low voltage charging circuit for power consumption and cost optimization
- USB cable inversion management

## Complies with the following standards

- IEC 61000-4-2 level 4:  $\pm 15$  kV contact on bridge inputs,  $\pm 12$  kV contact on USB data-lines inputs
- JESD22-A114D level 2

## Applications

- All wearable and IoT

## Description

The OCVPB21-13F6 is an integrated ESD, overvoltage and overcurrent protection with an integrated input rectification bridge to give flexibility for wearable and IoT customers to manage properly any kind of USB charging conditions with or without USB cable inversion.

Thanks to state of the art high voltage technology, ST can integrate in WLCSP package all required USB stressful high voltage and high current protection conditions (ESD, OVP and OCP) with control signals for wearable and IoT design optimization.

# 1 Functional description

OCVPB21-13F6 is a very integrated solution to be connected between USB cable and battery charge management chipset with very efficient protection to protect the system and the power management chipsets during battery charging.

As described herebelow , all protection functions are available to meet all stringent conditions of power supplies but also USB cable inversion:

- With 13 V input rectification bridge for polarity charging detection. Both signals (USB Vcc and USB datalines) are rerouted according to following rule (see Figure 2 and Table 3 )

**Table 1. Rectification bridge for polarity**

IN_A	IN_B	USB_INC	USB_IND
V <sub>CC</sub>	GND	D+	D-
GND	V <sub>CC</sub>	D-	D+

- Adjustable overcurrent protection to prevent peak current to meet a wide range of IoT and wearable applications
- Overvoltage protection to properly meet battery charging voltage conditions and protecting from -0.3 V to 13 V DC and to 20 V ringing at plug-in

**Figure 1. Application block diagram**

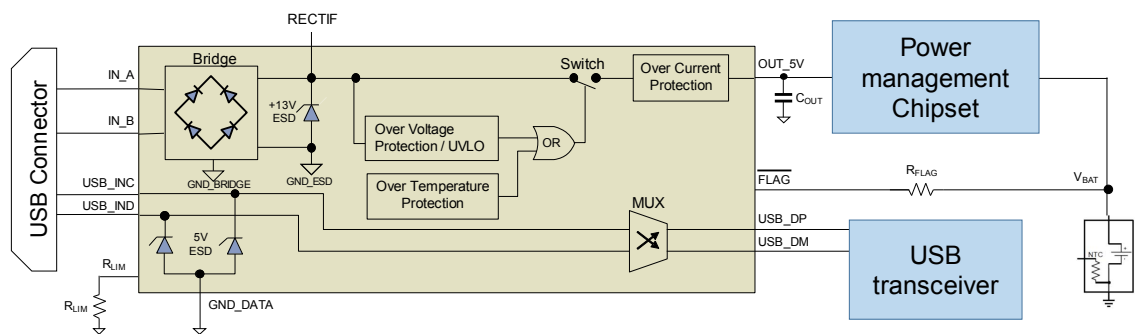

**Table 2. Block diagram reference**

Reference	Typical values	Comment
C <sub>OUT</sub>	≥ 10 μF 6V3	Low ESR capacitor
R <sub>LIM</sub>	From 51 Ω to 270 Ω	1% tolerance or better recommended
R <sub>FLAG</sub>	100 kΩ	

Figure 2. Functional diagram

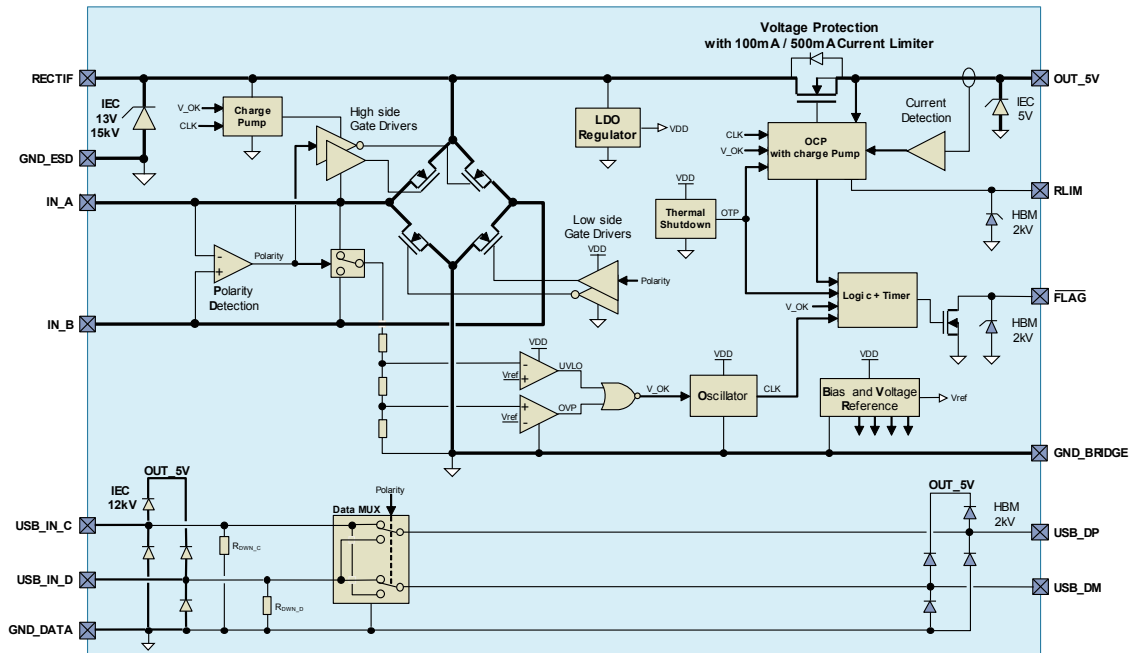
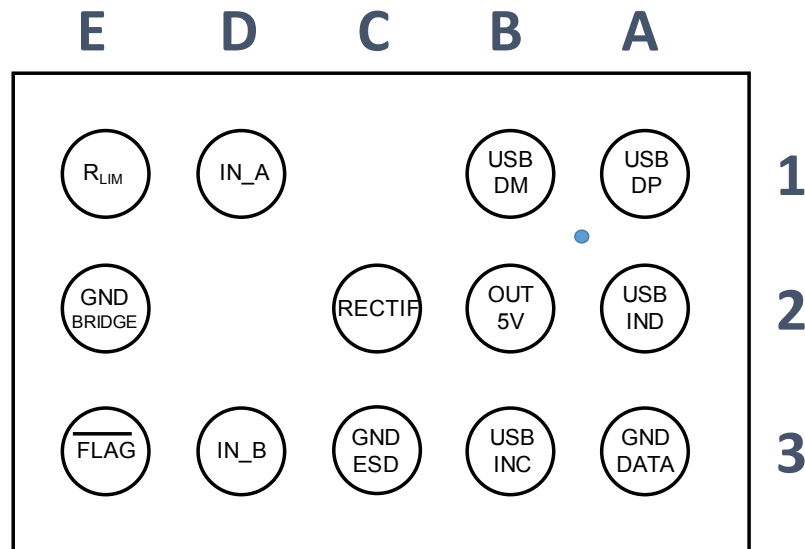

Figure 3. Pin numbering (bump side)



**Table 3. Pin description**

Pin	Name	Description	Pin	Name	Description
A1	USB_DP (OUT_USB_D+ DATA)	Output USB D+ dataline	C2	RECTIF	Output bridge rectification
A2	USB_IND	Input USB dataline - USB pin 3 connector (D+ or D-)	D1	IN_A (USB connector V <sub>CC</sub> or GND)	Input bridge rectification - USB connector (V <sub>CC</sub> or GND)
A3, C3, E2	GND DATA GND ESD GND BRIDGE	Ground dataline Ground ESD Bridge Ground bridge	D3	IN_B (USB connector GND or V <sub>CC</sub> )	Input bridge rectification - USB connector (GND or V <sub>CC</sub> )
B1	USB_DM (OUT_USB_D- DATA)	Output USB D- dataline	E1	R <sub>LIM</sub>	External resistor used to set current-limit threshold
B2	OUT_5V	Output USB 5 V voltage charging	E3	FLAG	Active-low open-drain output, asserted during overcurrent, over/under voltage and over temperature conditions
B3	USB_INC	Input USB dataline - USB pin 2 connector (D- or D+)			

## 1.1 Rectification bridge description

Thanks to an input rectification bridge, polarity of the charging cable can be detected and be rerouted in case of USB cable inversion.

During power-up stage, current will first flow in intrinsic body diodes of power MOS of the bridge.

During steady state, current will flow through power MOS of the bridge providing a low drop-out voltage.

## 1.2 OCP function description

Over current protection is required to prevent any inrush current or unexpected overcurrent that could damage the system.

Current limitation of the OCP will be set using an external resistor  $R_{LIM}$  (from 100 to 500 mA min) to meet a wide range of IoT and wearable applications.

Typical limitation current will be set at 10-15% above targeted value as described in Figure 7.

$I_{LIM}$  versus  $R_{LIM}$  definition is:  $I_{LIM} = (318 - R_{LIM}) / 0.447$

In case of slow overloading, the current is regulated at OCP level as described in Figure 4.

Figure 4. Load current regulation during slow overloadin

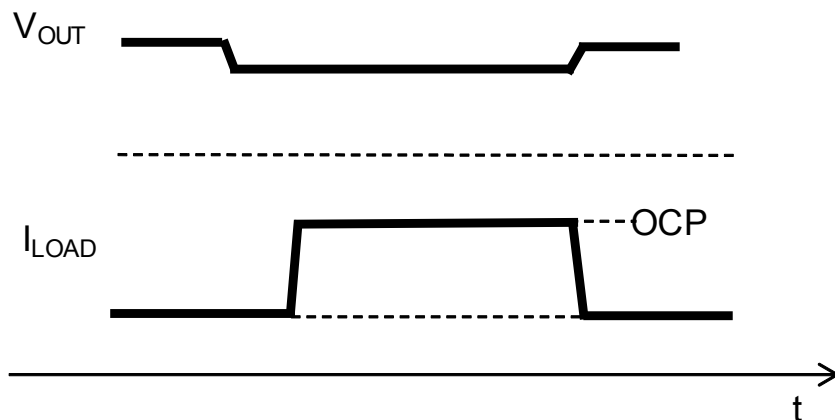

In case of fast overloading, the power-switch is switched-off in the microsecond range as described in Figure 5. Then the power-switch is slowly turned on and the load-current regulated at the OCP level.

Figure 5. Fast overloading

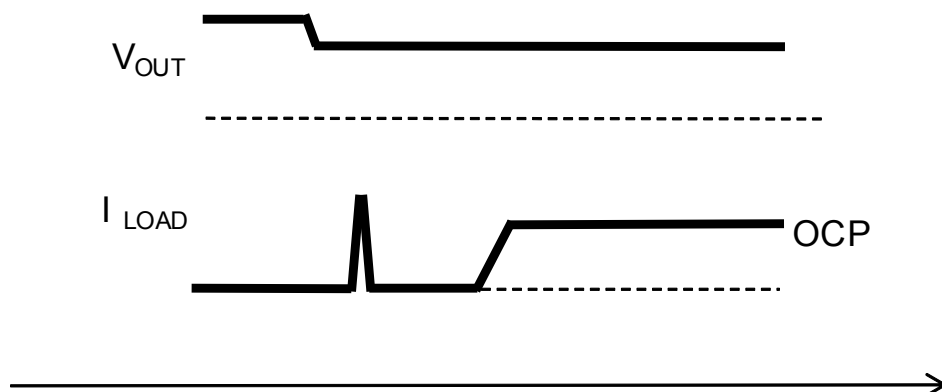

In case of fast short-circuit, the power-switch is switched-off in the microsecond range as described in Figure 6. Then the OCP level is folded back at around 75 mA.

Figure 6. Fast short circuit

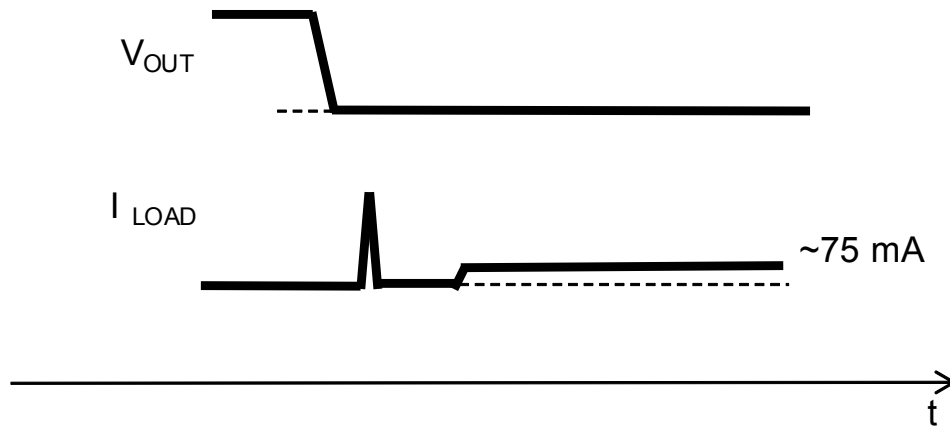

During OCP operation, a big power can be dissipated in the chip. If junction temperature reaches OTP level (150 °C), the power-switch is temporarily opened to cool the device. OCP is then re-enabled once  $T_j$  decreases by 30 °C.

Figure 7. Current limitation setting

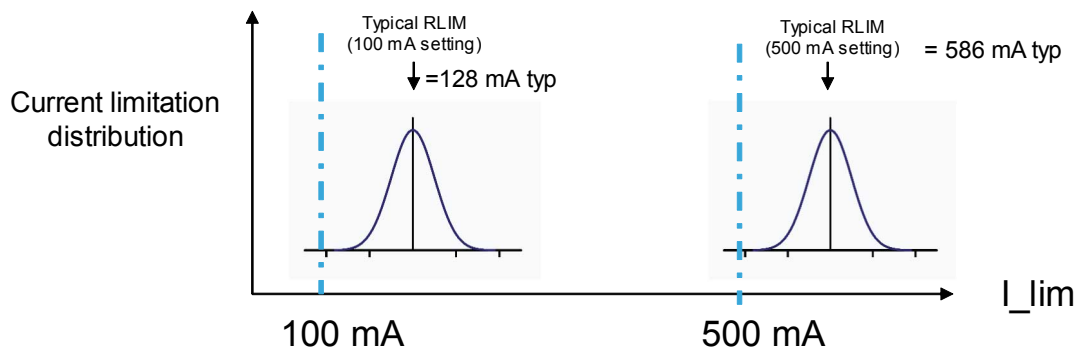

### 1.3 OVP function description

Both undervoltage lockout and overvoltage lockout are integrated to secure correct operating voltage conditions of connected Power management chipset.

In normal charging condition,  $V_{IN}$  and  $V_{OUT}$  can vary from 4.25 V to 5.5 V.

Under 4.25 V and over 5.5 V, UVLO or OVLO are activated to disable the output (OVP switch open and FLAG set to low - to inform protection Power management chipset).

#### 1.4 **FLAG output signal**

FLAG output signal (open-drain) is available to inform thermal shutdown or overvoltage or overcurrent or uncompleted start-up phase.

This signal is kept to low when product exceeds temperature conditions or voltage protection is activated or overcurrent occurs or start-up phase is still incomplete.

During normal conditions, this signal is at high level thanks to an external pull-up resistor.

## 2 Electrical characteristics

**Table 4. Absolute maximum ratings (limiting values)**

Symbol	Parameter	Test conditions	Value	Unit
$V_{PP\_BUS}$	ESD discharge on USB cable side, exceeds IEC 61000-4-2 level 4: pins D1 and D3 pins A2 and B3	Contact or air discharge pin to GND with $C_{OUT} \geq 10 \mu F^{(1)}$	$\pm 15$ $\pm 12$	kV
$V_{PP\_OUTPUT}$	ESD discharge (all pins), HBM -JESD22-A114D, level 2	Contact or air discharge	$\pm 2$	kV
$V_{IN\_MAX}$	Max transient input voltage	IN_A to GND or IN_B to GND (test pulse < 5 min)	-0.3 to +13.2	V
$V_{DATA\_MAX}$	Max data voltage	USB_INC, USB_IN, USB_DP and USB_DM	-0.3 to +5.5	V
$V_{RLIM\_MAX}$ , $V_{FLAG}$ and $OUT\_5V$	Max voltage range		-0.3 to +7	V
$I_{IN\_MAX\_DC}$	Max DC input current : IN_A and IN_B		600	mA
$I_{FLAG\_sink}$	Max sunk current through FLAG PIN		4	mA
$T_{STG}$	Storage temperature range		-55 to +150	°C
$T_{OP}$	Operating temperature range		-30 to +65	°C

1. With minimum 10  $\mu F$  low ESR capacitor connected to OUT\_5V

**Table 5. USB power electrical characteristic (-30 °C <  $T_{amb}$  < 65 °C, typ at  $T_{amb} = 25$  °C and  $V_{IN} = 5$  V unless otherwise noted)**

Symbol	Parameter	Test conditions	Min.	Typ.	Max.	Unit
$V_{IN}$	Input voltage range	IN_A to GND or IN_B to GND	4.25		5.55	V
$I_{Q\_IN}$	Supply quiescent current			400		$\mu A$
$UVLO_{OFF}$	Under-voltage lockout deactivation		3.8		4.25	V
$UVLO_{ON}$	Under-voltage Lockout		3.45		4.05	V
$OVP_{ON}$	Over-voltage protection deactivation		5.5		6.35	V
$OVP_{OFF}$	Over-voltage protection deactivation		5.45		6.2	V
$R_{INx}/OUT\_5V$	High side ON resistance	$I_{OUT} = 100$ mA		199		m $\Omega$
$R_{INx}/GND$	Low side ON resistance	$I_{IN\_x} = 100$ mA		119		m $\Omega$
$R_{LIM}$	OCP setting resistor range	$T = 25$ °C	51		270	$\Omega$
$I_{LIM}$	Overcurrent threshold	$R_{LIM} = 56$ $\Omega$ , $V_{OUT} = 4.5$ V	524	586	637	mA
		$R_{LIM} = 261$ $\Omega$ , $V_{OUT} = 4.5$ V	108	127.6	143.8	
$T_{sd}$	Thermal Shutdown		134	148	161	°C
$T_{sd\_hyst}$	Thermal Shutdown hysteresis		12	28	44	°C
$V_{OL\_FLAG}$	FLAG low state output voltage	$V_{IN} = 3.6$ V, $I_{Sink} = 4$ mA on FLAG			0.4	V
$I_{FLAG\_leak}$	FLAG leakage current	$V_{FLAG} = 5$ V			200	nA
$T_{ON}$	Activation time	From $V_{IN} > UVLO_{OFF}$ to FLAG = HIGH Z		1.2	2	ms



**Table 6. USB data characteristic (-30 °C < T<sub>amb</sub> < 65 °C, typ at T<sub>amb</sub> = 25 °C and V<sub>IN</sub> = 5 V unless otherwise noted)**

Symbol	Parameter	Test conditions	Min.	Typ.	Max.	Unit
V <sub>DATA</sub>	Dataline input Voltage range	USB_INC, USB_IND, USB_DP, USB_DM	-0.3		3.65	V
C <sub>ON</sub>	ON capacitance	V <sub>DATA</sub> = 0 V, F = 1 MHz		9		pF
F <sub>C</sub>	Cut-off frequency	-3dB bandwidth R <sub>L</sub> = 50 Ω, C <sub>L</sub> = 5 pF		420		MHz
		-3dB bandwidth R <sub>L</sub> = 50 Ω, C <sub>L</sub> = 0 pF		590		
R <sub>ON_DATA</sub>	On-Resistance	V <sub>DATA</sub> = 0 V to 0.4 V, I <sub>DATA</sub> = 8 mA			9.2	Ω
R <sub>ON_FLAT</sub>	On-Resistance flatness	V <sub>DATA</sub> = 0 V to 1 V, I <sub>DATA</sub> = 8 mA		1.6		Ω
R <sub>PULL_DOWN</sub>	Pull-down resistor between IN_C, IN_D and GND			100		kΩ

**Figure 8. USB2.0 high speed 480 Mbps eye diagram (pin A1 and B1 - with OCVPB21-13F6 and no load capacitor)**

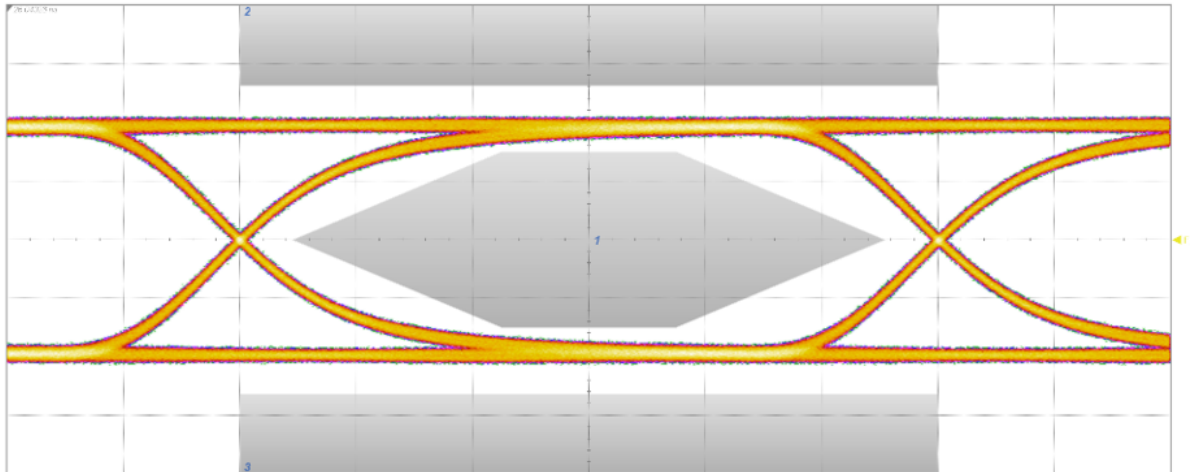
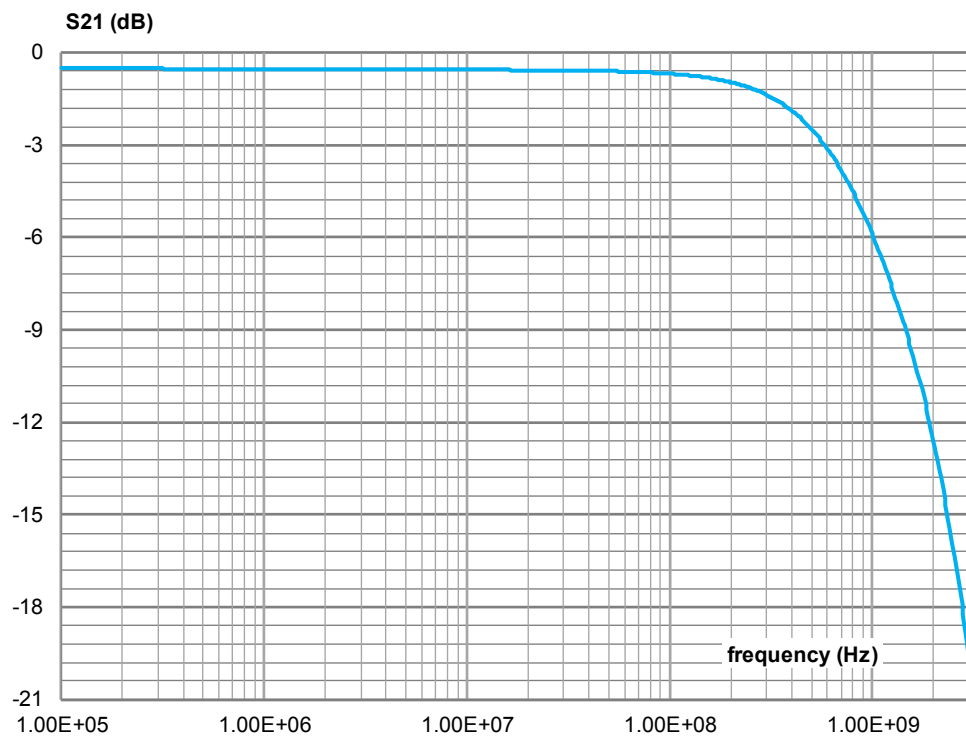

Figure 9.  $S_{21}$  measurement (pin A1 and B1 - with no load capacitor)



### 3 Package information

In order to meet environmental requirements, ST offers these devices in different grades of **ECOPACK** packages, depending on their level of environmental compliance. ECOPACK specifications, grade definitions and product status are available at: [www.st.com](http://www.st.com). ECOPACK is an ST trademark.

#### 3.1 WLCSP 13 bumps package information

Figure 10. WLCSP 13 bumps package outline

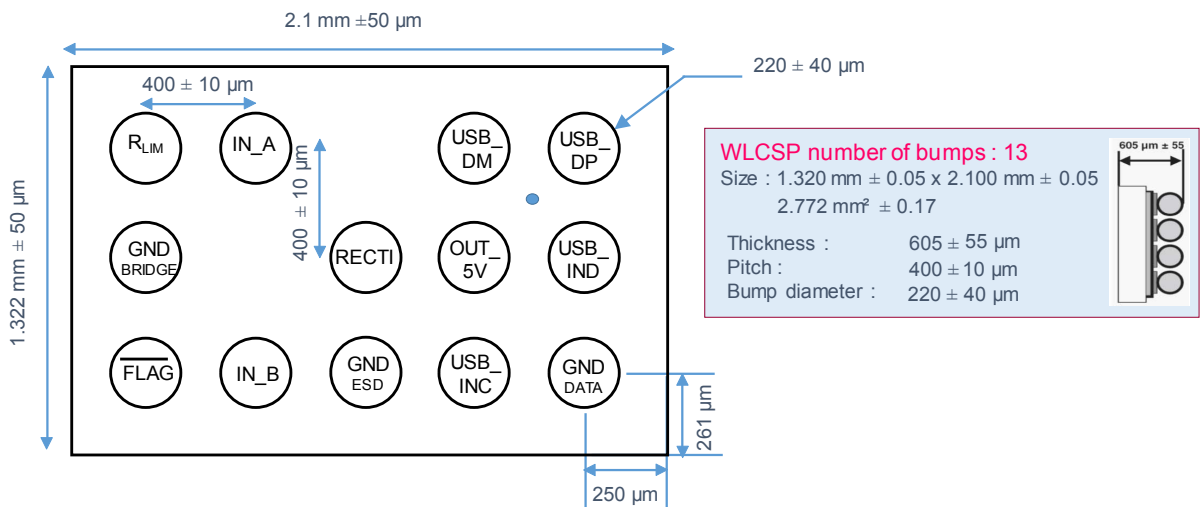

### 3.2 WLCSP 13 bumps packing information

**Figure 11. Marking**

Dot, ST logo  
 ECOPACK grade  
 xx = marking  
 z = manufacturing location  
 yww = datecode

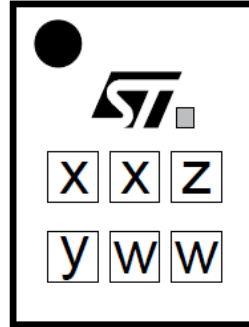

Note: More packing information is available in the application note:

- AN2348 Flip-Chip: "Package description and recommendations for use"

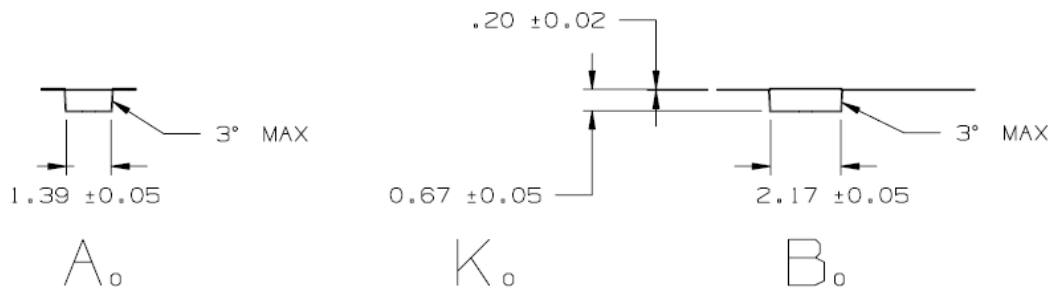
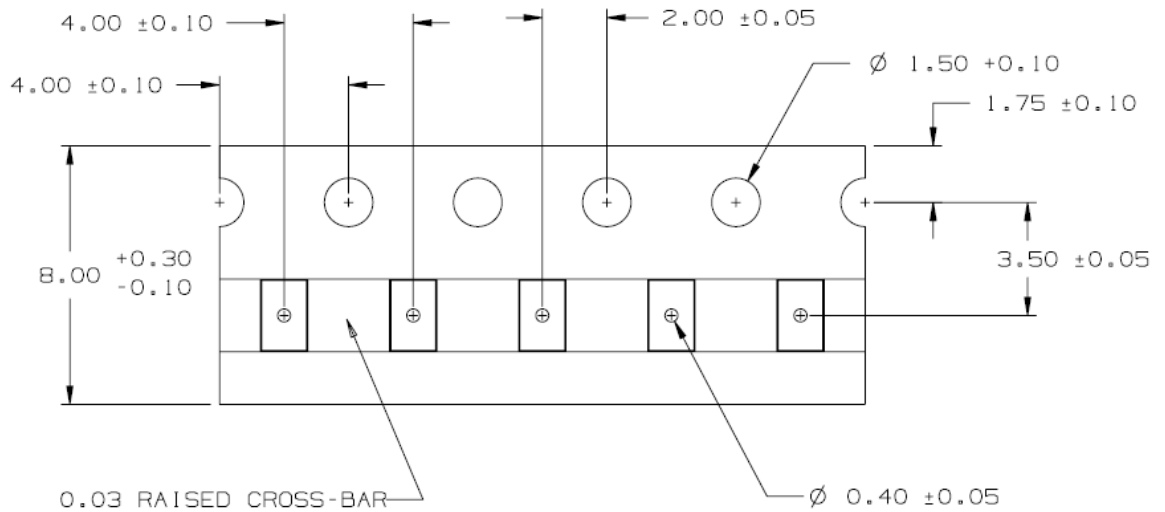
**Figure 12. WLCSP 13 bumps tape and reel specification (all dimensions in mm)**

## 4 Soldering assembly recommendations

### 4.1 PCB design recommendations for multi-bump Flip Chip

For optimum electrical performance and highly reliable solder joints, STMicroelectronics recommends the PCB design guidelines listed in [Table 7](#).

**Table 7. PCB design recommendations for multi-bump Flip Chips**

Name	Parameters
PCB pad design	Non solder mask defined micro via under bump allowed
PCB pad size	Ø = 200 µm (circular)
Solder mask opening	Ø = 275 µm
PCB pad finishing	Cu - Ni (2-6 µm) - Au (0.2 µm max) or Cu OSP (Organic Substrate Protection).

*Note:* A too thick gold layer finishing on the PCB pad is not recommended (low joint reliability)  
To optimize the natural self-centering effect of Flip Chips on PCB, PCB pad positioning and size have to be properly designed (see [Figure 13](#)).

#### Micro vias

An alternative to routing on the top surface is to route out on buried layers. To achieve this, the pads are connected to the lower layers using micro vias.

**Figure 13. Multi-bump Flip-Chip bump footprint**

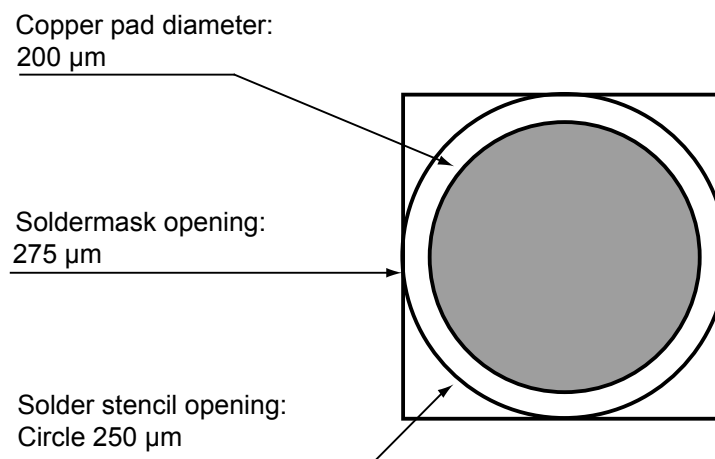

### 4.2 PCB assembly guidelines

For Flip Chip mounting on the PCB, STMicroelectronics recommends the use of a solder stencil aperture of 250 µm and a typical stencil thickness of 80 µm. Flip Chips are fully compatible with the use of near eutectic 95.8% Sn, 3.5% Ag, 0.7% Cu solder paste with no-clean flux. ST's recommendations for Flip-Chip board mounting are illustrated on the soldering reflow profile shown in [Figure 14](#).

**Figure 14. ST ECOPACK recommended soldering reflow profile for Flip Chip mounting on PCB (definitions)**

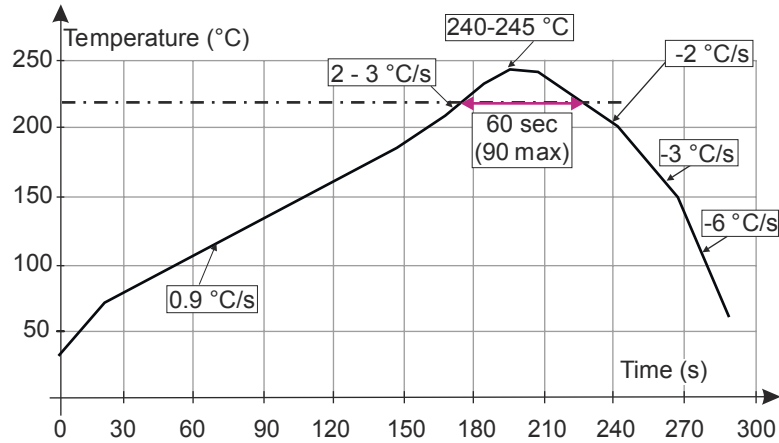

**Table 8. ST ECOPACK recommended soldering reflow profile for Flip Chip mounting on PCB (value)**

Profile	Value	
	Typ.	Max.
Temp. gradient in preheat (T = 70 – 180 °C)	0.9 °C/s	3 °C/s
Temp. Gradient (T = 200 – 225 °C)	2 °C/s	3 °C/s
Peak temp. in reflow	240 – 245 °C	260 °C
Time above 220 °C	60 s	90 s
Temp. gradient in cooling	-2 to -3 °C/s	-6 °C/s
Time from 50 to 220 °C	160 to 220 s	

### 4.3 Layout recommendations

Low impedance trace are recommended for IN\_A, IN\_B, OUT\_5V and GND\_ESD to ensure layout optimization for ESD.

We recommend also to place C<sub>OUT</sub> (see Table 2. Block diagram reference) as close as possible of OCVPB21-13F6.

To maximize current limit accuracy, we recommend also to place R<sub>LIM</sub> (see Table 2. Block diagram reference) as close as possible of OCVPB21-13F6 (with Z < 500 mΩ).

Traces for USB data lines should be designed with 90 Ω differential impedances (USB\_INC, USB\_IND, USB\_DP and USB\_DM tracks).

## 5 Ordering information

Figure 15. Ordering information scheme

OCVP B 2 1 - 13 F6

ESD, overcurrent and overvoltage protection

With rectification bridge

With two USB2.0 datalines ESD protection

Version 1 with 15kV ESD in Power lines

With 13 bumps

Package

F = Flip Chip

6 : lead-free, pitch = 400 μm, bump = 220 μm

Table 9. Ordering information

Order code	Marking	Package	Weight	Base qty.	Delivery mode
OCVPB21-13F6	NL	WLCSP	6 mg	5000	Tape and reel

Note: More information is available in AN2348 application note :

- STMicroelectronics 400 micro-meter Flip Chip: package description and recommendation for use

## Revision history

**Table 10. Document revision history**

Date	Revision	Changes
08-Nov-2019	1	Initial release.
21-Dec-2020	2	Inserted protection logo. Updated <a href="#">Table 5</a> and <a href="#">Figure 10</a> .



**IMPORTANT NOTICE – PLEASE READ CAREFULLY**

STMicroelectronics NV and its subsidiaries (“ST”) reserve the right to make changes, corrections, enhancements, modifications, and improvements to ST products and/or to this document at any time without notice. Purchasers should obtain the latest relevant information on ST products before placing orders. ST products are sold pursuant to ST’s terms and conditions of sale in place at the time of order acknowledgement.

Purchasers are solely responsible for the choice, selection, and use of ST products and ST assumes no liability for application assistance or the design of Purchasers’ products.

No license, express or implied, to any intellectual property right is granted by ST herein.

Resale of ST products with provisions different from the information set forth herein shall void any warranty granted by ST for such product.

ST and the ST logo are trademarks of ST. For additional information about ST trademarks, please refer to [www.st.com/trademarks](http://www.st.com/trademarks). All other product or service names are the property of their respective owners.

Information in this document supersedes and replaces information previously supplied in any prior versions of this document.

© 2020 STMicroelectronics – All rights reserved

## X-ON Electronics

Largest Supplier of Electrical and Electronic Components

*Click to view similar products for* [Current & Power Monitors & Regulators](#) *category:*

*Click to view products by* [STMicroelectronics](#) *manufacturer:*

Other Similar products are found below :

[NCP347MTAHTBG](#) [NCS37000MNG](#) [NCP4353BSNT1G](#) [MAX4845DEYT+T](#) [ZXCT1080QE5TA](#) [NCP4353ASNT1G](#) [ZXCT1008QFTA](#)  
[UC3838ADW](#) [NCP361SNT1G](#) [ZXCT1023DFGTA](#) [ADM1294-1AARUZ-RL7](#) [LT3092ETS8#TRPBF](#) [LTC4151IMS-1#PBF](#) [LM334S8#PBF](#)  
[INA203AIDR](#) [ADM1294-1AACPZ](#) [ADM1294-1BACPZ](#) [ADL5317ACPZ-REEL7](#) [ADM1041ARQZ](#) [ADM1192-1ARMZ-R7](#) [ADM1293-1BARUZ](#) [ADM1294-1AARUZ](#) [LT3092EST#TRPBF](#) [LTC1921CMS8#PBF](#) [LTC1921IS8#PBF](#) [LTC1392CS8#PBF](#) [LTC1921CS8#PBF](#)  
[LTC2921CGN#PBF](#) [LTC2947IUHF-65#PBF](#) [ZXCT1009FTA](#) [DM7332G-00364-B1](#) [CS5460A-BSZ](#) [LT2940IDD#PBF](#) [ZXCT1110W5-7](#)  
[ZXCT1083E5TA](#) [ZXCT1021E5TA](#) [ZXCT1022E5TA](#) [ZXCT1041E5TA](#) [ZXCT1051E5TA](#) [ZXCT1080E5TA](#) [ZXCT1107SA-7](#)  
[INA285AQDGKRQ1](#) [INA286AQDGKRQ1](#) [IR3725MTRPBF](#) [ISL28023FR12Z-T7A](#) [ISL28025FI12Z-T7A](#) [IXCY10M45S](#)  
[LTC2970IUFD#PBF](#) [LTC2991IMS#TRPBF](#) [LTC2992CDE#PBF](#)